



Comparison of Structural Elements Response in PLAXIS 3D and SAP2000

Gragnano C. G., Fargnoli V., Boldini D. (Corresponding Author), University of Bologna, Italy
 Amorosi A., Technical University of Bari, Italy

In this paper the response of a number of structural models subjected to different loading conditions is analysed with the codes PLAXIS 3D and SAP2000. The goal of such a comparison is the assessment of the structural elements performance in PLAXIS 3D as compared to that obtained by the well-known SAP2000, a widely used code for structural analysis. An overall good match was obtained, as such highlighting the possibility to use the code PLAXIS 3D to perform both structural and geotechnical calculations in soil-structure interaction problems.

➤ The impulse in software technology and computational power of personal computers has recently offered the possibility to perform fully-3D finite element analyses of complex engineering projects. In particular, in the field of civil engineering it is nowadays feasible to perform the analysis of a soil-structure interaction problem by a unique model, accounting at the same time for both geotechnical and structural issues.

The three-dimensional version of the finite element code PLAXIS includes a wider choice of structural elements (such as beams, plates and node-to-node anchors), enhancing its modelling capability at the cost of a deeper structural competence required to the user. This paper provides a contribution on this specific topic, illustrating a number of structural models, where the different structural elements were employed, to investigate and clarify their response under different loading conditions. These models range from simple single-bay spatial frame to multi-storey frame with cross-bracings simulating the presence of infilled panels. All the models are assumed fixed at base, i.e. no foundation systems were considered, in order to focus the attention on the structural response only.

The observed behaviour was compared with that obtained analysing the same structure by the finite element code SAP2000, a widely used software for structural analysis. This assessment was useful to highlight some differences in the formulation of the corresponding structural elements in the two codes.

Modelling a Spatial Frame with Beams and Columns: Model M1

The reference structure of the case study described in this section is a single-bay spatial frame fixed at the base and consisting only of beams and columns all characterised by a section

Unit weight γ (kN/m ³)	24
Young's modulus E (GPa)	25
Poisson's ratio ν (-)	0.2

Table 1: Material properties of beams and columns

Unit weight γ (kN/m ³)	32.36
Young's modulus E (GPa)	10
Poisson's ratio ν (-)	0.2

Table 2: Material properties of the isotropic floor slab

of 30 cm x 30 cm (Fig. 1). The figure illustrates the dimension of the structural elements, the right-handed global reference system (x, y, z) and the local coordinate (s), this latter represented only for beam 2-6 for sake of simplicity.

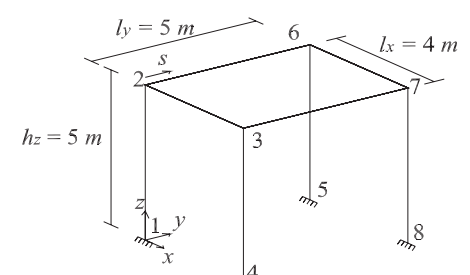

Figure 1: Spatial frame with beams and columns and global coordinate system

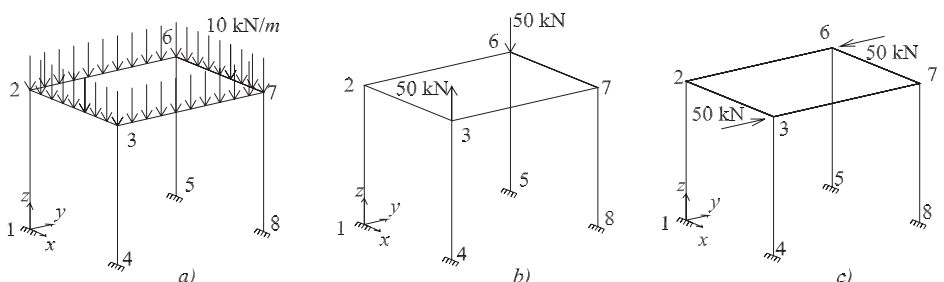

Figure 2: Three-dimensional view of model M1 under loading conditions C1 (a), C2 (b) and C3 (c)

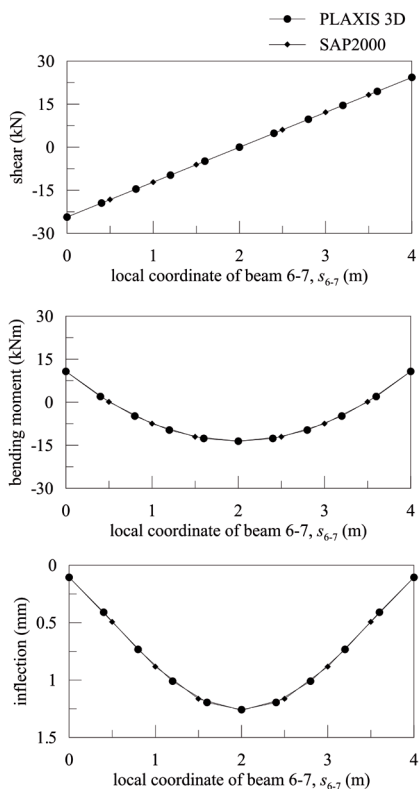

Figure 3: Model M1: response of beam 6-7 under loading condition C1 in PLAXIS 3D and in SAP2000

In this example, defined model M1, as in the following ones, beams and columns are modelled as one-dimensional elements of frame-type in SAP2000 and beam-type in PLAXIS 3D. This latter element, differently from the frame type, is not able to react to torsional actions. Both elements allow for deflections due to shearing as well as bending.

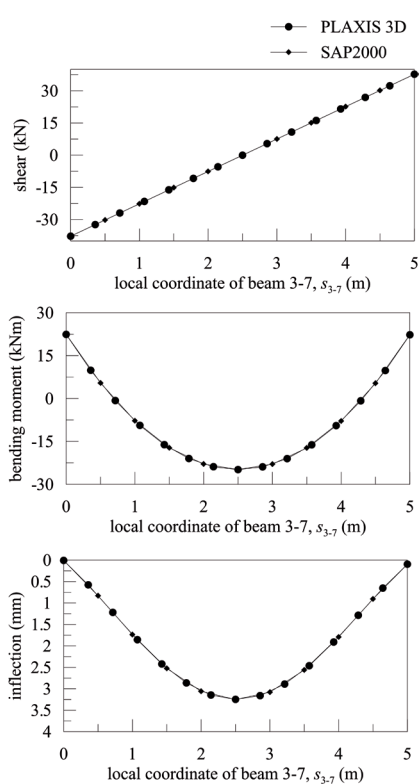

Figure 4: Model M1: response of beam 3-7 under loading condition C2 in PLAXIS 3D and in SAP2000

A linear-elastic constitutive law was adopted for these elements, whose parameters were selected consistently with the assumed reinforced concrete material (Table 1).

All the six displacement components were restrained at the base of the model in SAP2000. In an interaction problem, this condition simulates

a rigid contact at the soil-structure interface, thus being appropriate for the modelling of a soil-foundation system much stiffer than the superstructure.

On the contrary, a foundation plinth 1 m high and characterised by a square section (1 m x 1 m) was assumed at the base of each column in the PLAXIS 3D analysis, modelled by a two-dimensional plate element. As this code does not allow to perform numerical analyses without including soil elements, a soil volume (12 m x 15 m x 15 m) was defined at the frame base, assuming for it a very rigid behaviour, characterised by a Young's modulus of 750 GPa and a Poisson's ratio equal to zero.

The response of the model was analysed considering the following loading conditions:

- C1 = gravity loads + uniformly distributed vertical loads equal to 10 kN/m acting on the beams (Fig. 2 a);
- C2 = gravity loads + concentrated vertical loads of 50 kN acting at nodes 3 and 6 (Fig. 2 b);
- C3 = gravity loads + concentrated horizontal loads of 50 kN acting at nodes 3 and 6 (Fig. 2 c).

Numerical analyses were carried out using a finite element mesh of medium density in PLAXIS 3D (i.e. the average size of the finite element is equal to 1.3 m), while adopting the default option in SAP2000.

Distributions of shear, bending moment and inflection for beams 6-7 (relative to loading conditions C1 and C3) and 3-7 (for loading condition C2) as calculated by the two codes are shown in Figures 3, 4 and 5. This latter figure also reports the horizontal displacements along x direction of column 1-2 under loading condition C3.

It is possible to note that the results calculated by SAP2000 and PLAXIS 3D are fairly coincident in terms of shear, bending moment and inflection,

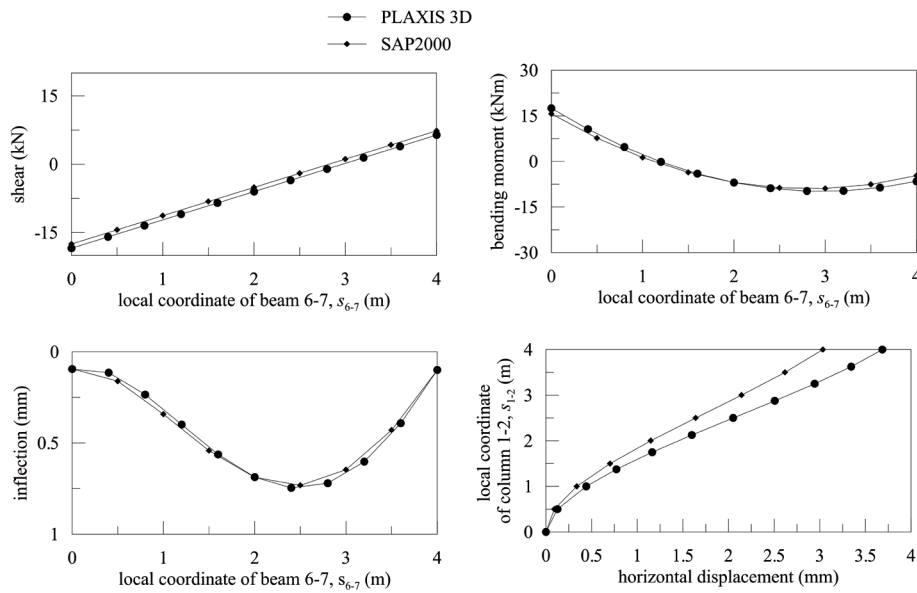

Figure 5: Model M1: response of beam 6-7 and column 1-2 under loading condition C3 in PLAXIS 3D and in SAP2000

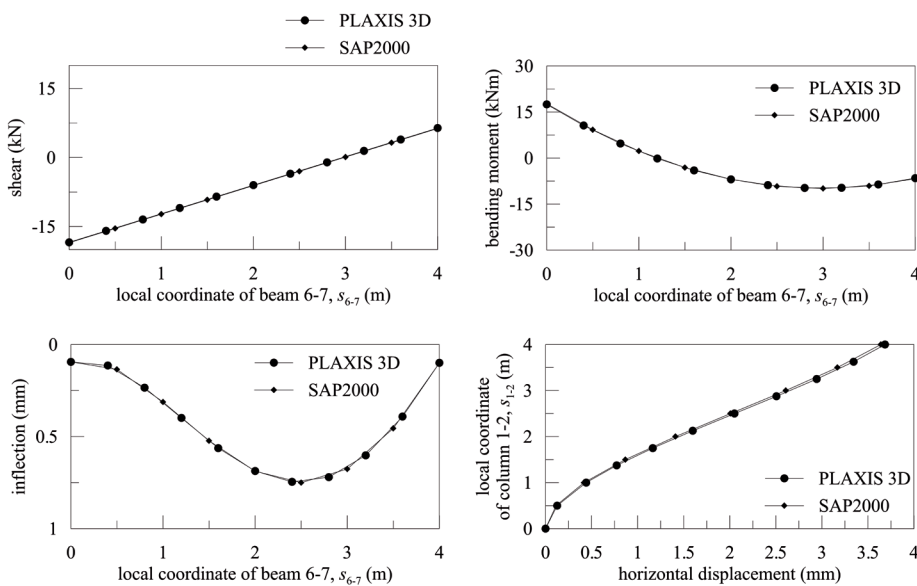

Figure 6: Model M1: response of beam 6-7 and column 1-2 under loading condition C3 in PLAXIS 3D and in SAP2000 without torsional constraints at column heads.

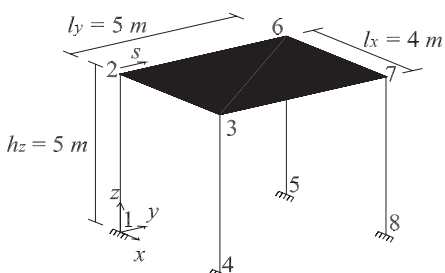

Figure 7: Spatial frame with beams, columns and a floor slab

t_w (m)	0.3
h_w (m)	4
E_w (GPa)	3
E_c (GPa)	25
I_c (m ⁴)	0.000675
θ (°)	45
λ_w (1/m)	1.351
d_w (m)	5.657
b_w (m)	0.504

Table 3: Values of the parameters for estimating the equivalent diagonal width, b_w

while the horizontal displacements evaluated for column 1-2 differ in a non-negligible way. Such difference is due to the characteristics of the beam element in PLAXIS 3D which, as anticipated, does not sustain the torsional action induced by loading condition C3 (Fig. 5). This is confirmed by the results of a further analysis, illustrated in Figure 6, identical to the previous one except for the torsional constraint at the column head which was removed in the SAP2000 model: this modification leads to an almost coincident response as obtained by the two codes.

Modelling a Floor Slab in a Simple Spatial Frame: Model M2

Figure 7 shows a single-bay spatial frame differing from the simple structure of model M1 (Fig. 1) for the presence of a floor slab at the top. A brick-reinforced concrete floor slab is a structural element having a heterogeneous composition (i.e. reinforced concrete and brick) and a different stiffness in the two plane directions (i.e. higher stiffness in the warping direction). It is subjected to a plane stress condition and it is mainly loaded in its out-of-plane direction.

The numerical model of this structure (model M2) is coincident to model M1 in terms of beams, columns and constraint conditions at the base.

Concerning the floor slab, two different mechanical hypotheses were considered, namely isotropic and anisotropic. This latter allows to reproduce the main characteristic of a floor slab, that is a structural element rigid in its own plane and capable of differentiating the load transferred to the main beams as compared to the secondary ones.

The isotropic behaviour was obtained in PLAXIS 3D using a two-dimensional linear-elastic plate element of thickness equal to 25 cm with the material properties listed in Table 2.

A two-dimensional shell element with the same geometrical and material properties was selected to model the isotropic floor slab in SAP2000.

The presence a floor slab with anisotropic behaviour was represented in SAP2000 without simulating the structural element itself, but just applying the constraint diaphragm to the nodes 2, 3, 6 and 7 (Fig. 7). This constraint, generally used to model structural components which have very high in-plane stiffness, forces the nodes belonging to the plane of the slab to move together in a rigid way. Assuming the warping direction of the floor slab along x-axis and according to the current design practice, the weight of the floor slab was accounted for applying vertical forces to the main beams (in y direction) and to the secondary ones (in x direction) with reference to the influence areas: a load equal to 64.1 kN and 16.8 kN was attributed to the main and secondary beams, respectively. In particular, the first load is equal to half of the floor slab weight (80.9 kN, being the total weight equal to 161.8 kN), reduced of the load (16.8 kN) transferred to the adjacent secondary beams by a floor slab slice 50 cm wide.

When modelling the same slab in PLAXIS 3D, an anisotropic elastic model was employed. More specifically, according to the warping direction along x-axis, the Young's modulus, E_y , and the shear modulus, G_{yz} , were reduced as compared to those adopted in the isotropic case. The amount

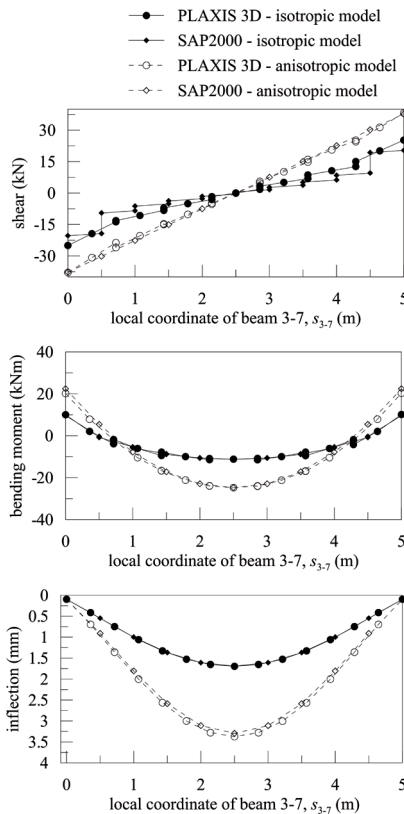

Figure 8: Model M2: response of beam 3-7 under loading condition C1 in PLAXIS 3D and in SAP2000

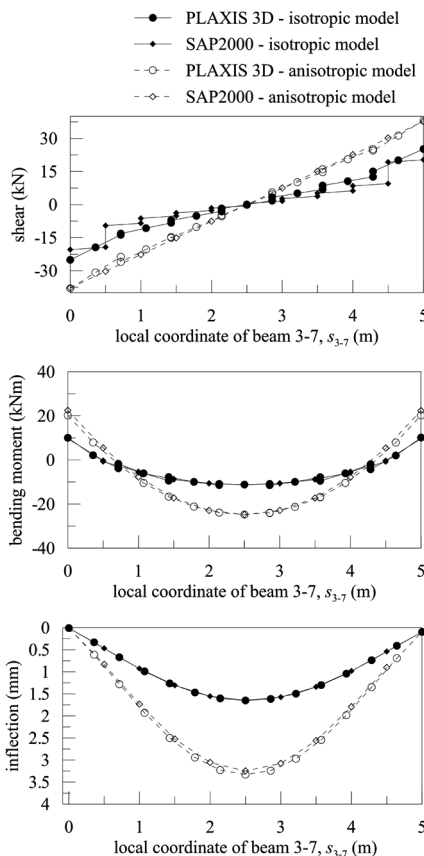

Figure 9: Model M2: response of beam 3-7 under loading condition C2 in PLAXIS 3D and in SAP2000

of the necessary reduction of the moduli to match the reference results obtained by SAP2000 is equal to 10%, as such the adopted parameters are $E_y = 1$ GPa; $G_{yz} = 416.7$ MPa.

The same loading conditions previously analysed for model M1 were considered, namely C1 (taking also into account the floor slab weight), C2 and C3.

The finite element mesh used for this model in PLAXIS 3D is similar to that defined in model M1; in SAP2000, on the contrary, the mesh of the model with isotropic slab was modified to make it roughly equivalent to that defined in PLAXIS 3D. This expedient is related to the fact that in SAP2000 the load of the floor slab is transferred to the beams in correspondence of the mesh nodes, therefore a similar finite element discretisation is required in order to obtain consistent results by the two different codes.

Figures 8, 9 and 10 show the comparison between models M1 and M2 in terms of shear, bending moment and inflection for beam 3-7 under loading conditions C1, C2 and C3, respectively. Figure 10 also shows the horizontal displacements of column 1-2 along x-axis.

Results demonstrate the good agreement between the structural responses obtained by the two different numerical codes. In general, it is possible to observe an equivalent response of beam 3-7 under loading conditions C1 and C2 for model M2 too. As expected, the different assumption concerning the behaviour of the floor slab (i.e. isotropic or anisotropic) plays an essential role in the intensity and distribution of shear, bending moment and inflection.

In the anisotropic case, the structural element 3-7 is one of two main beams of the floor slab and it results to be more heavily loaded as compared to what observed in the isotropic model, where all the beams were equally loaded per unit of length.

On the contrary, the different mechanical hypotheses seem to have a barely relevant influence on the horizontal displacement of the column: this should be due to the fact that in both isotropic and anisotropic cases the relevant shear stiffness G_{xy} assumes the same value, leading to a similar head restraint acting on the column, therefore resulting in a correspondingly similar displacement pattern.

Modelling a 2D-Frame with Diagonal Elements: Model M3

The simple structure shown in Figure 11 is a single-bay plane frame with cross bracings. These elements are commonly adopted in numerical studies to account for infill panels (e.g.: Panagiotakos and Fardis, 1996). Those latter, although being non-structural components, significantly contribute to the overall structural response in the in-plane horizontal direction, leading to a generally stiffer behaviour as compared to open-frame ones.

In the corresponding numerical model, defined as model M3, the structural elements (i.e. beam and columns) are represented by frames and beams in SAP2000 and PLAXIS 3D, respectively, and are characterised by the material properties listed in Table 1. The base of the frame is constrained as in all the other models.

The diagonal elements of the frame were modelled in order to make them equivalent to a building infill panel, adopting a simplified version of a formulation proposed in the literature (Panagiotakos and Fardis, 1996; Fardis, 1997). The width of the cross bracings, b_w , was defined with reference to the expression of Mainstone (1971):

$$b_w = 0.175 \cdot (\lambda_h \cdot h_w)^{-0.4} \cdot d_w \quad (1)$$

where: d_w is the diagonal length of the panel, h_w is the panel height and the parameter λ_h is equal to:

$$\lambda_h = \sqrt[4]{\frac{E_w \cdot t_w \cdot \sin(2\theta)}{4 \cdot E_c \cdot I_c \cdot h_w}} \quad (2)$$

where E_w and E_c are the Young's moduli of the infill panel and of the reinforced concrete structural elements surrounding the panel, respectively; θ is the angle formed by the diagonal of the infill panel with respect to the horizontal axis; t_w is the panel thickness; I_c is the moment of inertia of the columns adjacent to the infill panel. The values of these parameters are summarised in Table 3.

The cross bracings were modelled as weightless one-dimensional elements reacting only to axial stress (denoted as truss elements in SAP2000 and node-to-node anchor elements in PLAXIS 3D), characterised by an axial stiffness equal to $K = E_w \cdot b_w \cdot t_w = 450000$ kN. An elastic-plastic constitutive law was selected for the elements to introduce a limit value of the tensile strength equal to zero, aimed at neglecting tensile stresses for the cross bracings.

The response of model M3 was assessed by considering the structural elements weight (beams and columns) and a force of 20 kN applied at node 2 along x-axis (loading condition C4). Figure 12 shows a perfect match among the results of the two models in terms of normal stress acting in column 3-4 and diagonal element 2-4; shear, bending moment and inflection in beam 2-3; horizontal displacement in column 3-4.

Modelling a Spatial 3-Storey Frame with and without Cross Bracings: Models M4(I) and M4(II)

In this section the responses of two 3-storey frame structures subjected to horizontal loads are compared, the structures differing only for the presence of cross bracings (Fig. 13). The inter-storey height is 4 m and the beams length is equal to 4 m in x direction and 5 m in y direction.

The numerical models of the open-frame structure and that of the structure with diagonal elements are denoted as M4(I) and M4(II). In the models beams and columns are represented by one-dimensional elements (frames and beams in the two codes) and, for sake of simplicity, the floor slabs are modelled as linear-elastic-isotropic elements of shell-type in SAP2000 and plate-type in PLAXIS 3D. For both models the mechanical properties of columns, beams and floor slabs are those listed in Tables 1 and 2; the usual rigid constraint conditions are assumed at the base of the frames.

The equivalent width d_w of the cross bracings, modelled as node-to-node anchor and truss elements in PLAXIS 3D and SAP2000 respectively, was defined using Eq. (1) and the same elastic-plastic constitutive law assumed for model M3 was selected in this case.

Both models were analysed under gravity loading

and horizontal ones acting along x-axis, those latter equal to 20 kN, 40 kN and 60 kN at the first, second and third frame level respectively (loading condition C5) (Fig. 13). A control point position was selected at the top level (node 3.4) as representative of the horizontal displacement of the structure.

The horizontal displacement distributions in columns 0.4-1.4, 1.4-2.4, 2.4-3.4 are reported in Figure 14 for the two models. It is worth noting that both codes provide the same results: the maximum horizontal displacement is equal to 8 cm for model M4(I) and about 0.8 cm for model M4(II). The outcome of the analyses clearly highlights the effect of claddings on the overall structural stiffness, although simply accounted for by means of equivalent diagonal elements: in fact, the presence of cross bracings produces a horizontal displacement reduction of an order of magnitude as compared to the reference case where they are not included.

Conclusions

In the paper the response of a number of structural models subjected to different loading conditions was analysed by the finite element codes PLAXIS 3D and SAP2000. The main outcomes resulting from the comparison, carried out in terms of stress and displacements, can be summarised as follows:

- beams and columns can be modelled with frame elements in SAP2000 and beam elements in PLAXIS 3D. The main difference in the element formulations resides in the inability of beam elements to react to torsional actions. In fact, the release of torsional constrains in SAP2000 produces perfectly matching results;
- the floor slab can be modelled in SAP2000 by a shell element or using a diaphragm constraint combined with some additional vertical forces at the top of the columns to simulate the effect of the slab weight. In the first case an isotropic behaviour is obtained, while in the latter a more realistic response is reproduced, as it allows to account for the higher stiffness observed in the warping direction. A plate element is instead available in PLAXIS 3D. The use of an isotropic formulation allows to nicely reproduce the response of the shell element, while an anisotropic model should be selected to fit, after a careful calibration of its elastic parameters, the response of the more advanced scheme of SAP2000;
- infill panels can be modelled in a simplified manner as cross bracings, whose characteristics were obtained using the formulation proposed by Mainstone (1971). Truss and node-to-node anchor elements were used respectively in SAP2000 and PLAXIS 3D, leading to perfectly consistent structural responses.

This study should be considered as a preliminary step towards more complex soil-structure interaction problems, which indeed require a good level of confidence in the use of structural elements in 3D analyses with PLAXIS.

Acknowledgements

Special thanks to Ph.D. Eng. Francesco Tucci for his helpful support during this research activity.

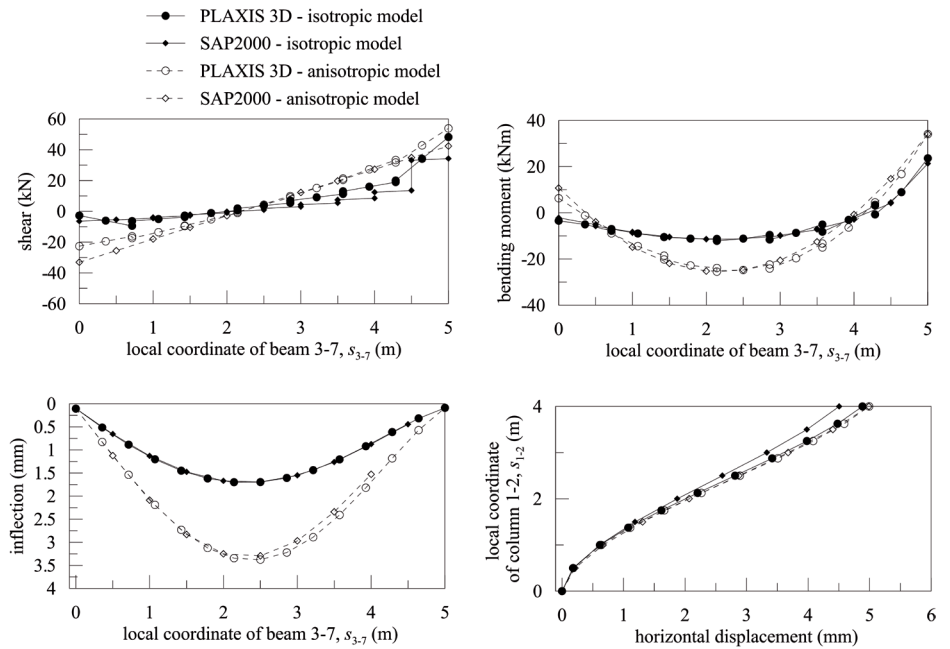

Figure 10: Model M2: response of beam 3-7 and column 1-2 under loading condition C3 in PLAXIS 3D and in SAP2000

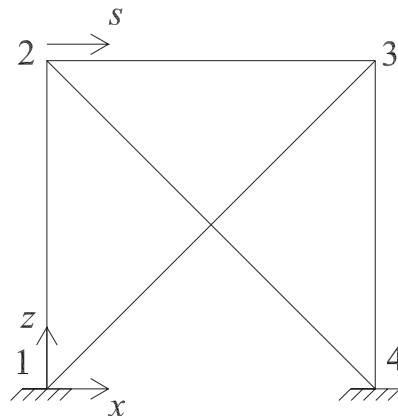

Figure 11: 2D frame with cross bracings

References

1. M.N. Fardis, 1997. Experimental and numerical investigations on the seismic response of RC infilled frames and recommendations for code provisions. Report ECOEST-PREC8 No. 6. Prenormative research in support of Eurocode 8.
2. R.J. Mainstone, 1971. On the stiffnesses and strengths of infills frames. Proc. Inst. Civil. Engineers, iv 7360s: 59-70.
3. T.B. Panagiotakos and M.N. Fardis, 1996. Seismic response of infilled RC frames structures. 11th World Conference on Earthquake Engineering, Acapulco, México, June 23-28. Paper No. 225.

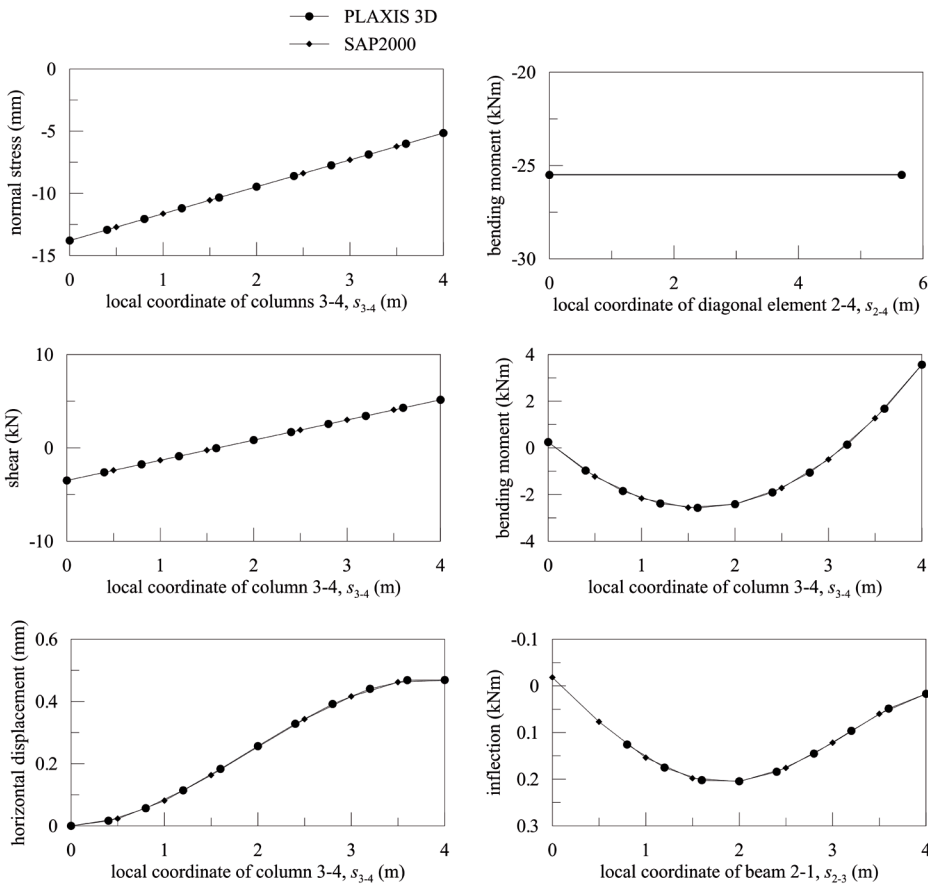

Figure 12: Model M3: responses of column 3-4, beam 2-3, and diagonal element 2-4 under C4 load condition in PLAXIS 3D and in SAP2000

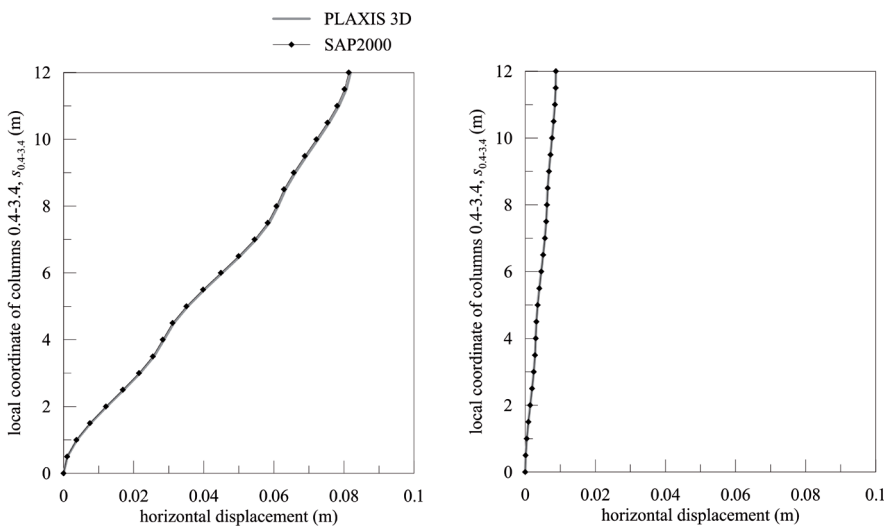

Figure 14: Models M4(I) and M4(II): comparison between horizontal displacements obtained in PLAXIS 3D and in SAP2000 with (on the right) and without (on the left) cross bracings.

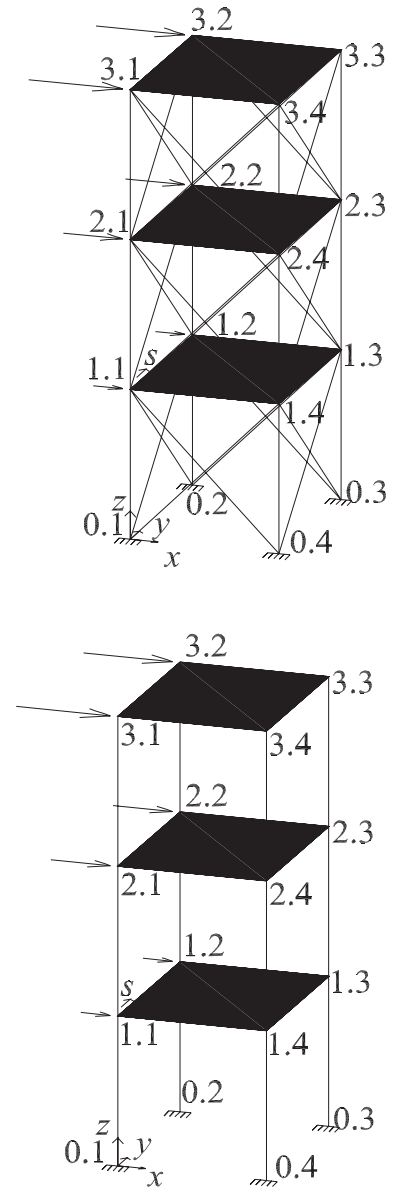

Figure 13: Three-dimensional view of the structures and loading distributions with (top) and without (bottom) cross bracings. Each node of the frame is defined through a double number: the first indicates the level it belongs to, while the second is a sequential number.