

# 6

## Dry excavation using a tie back wall [ADV]

This example involves the dry construction of an excavation. The excavation is supported by concrete diaphragm walls. The walls are tied back by prestressed ground anchors.

PLAXIS 2D allows for detailed modelling of this type of problem. It is demonstrated in this example how ground anchors are modelled and how prestressing is applied to the anchors. Moreover, the dry excavation involves a groundwater flow calculation to generate the new water pressure distribution. This aspect of the analysis is explained in detail.

### Objectives

- Modelling ground anchors.
- Generating pore pressures with a groundwater flow calculation.
- Displaying the contact stresses and resulting forces in the model.
- Scaling the displayed results.

### Geometry

The excavation is 20 m wide and 10 m deep. 16 m long concrete diaphragm walls of 0.35 m thickness are used to retain the surrounding soil. Two rows of ground anchors are used at each wall to support the walls. The anchors have a total length of 14.5 m and an inclination of  $33.7^\circ$  (2:3). On the left side of the excavation a surface load of  $10 \text{ kN/m}^2$  is taken into account.

The relevant part of the soil consists of three distinct layers. From the ground surface to a depth of 3 m there is a fill of relatively loose fine sandy soil. Underneath the fill, down to a minimum depth of 15 m, there is a more or less homogeneous layer consisting of dense well-graded sand. This layer is particularly suitable for the installation of the ground anchors. The underlying layer consists of loam and lies to a large depth. 15 m of this layer is considered in the model as shown in [Figure 79](#) (on page 102).

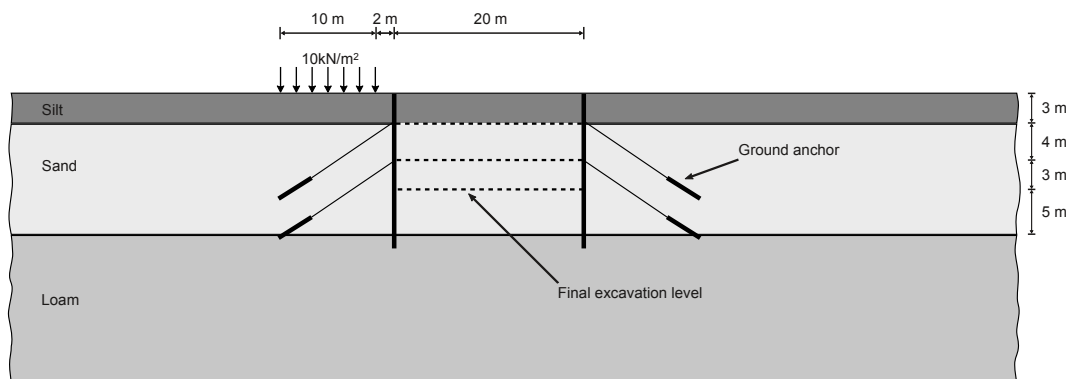

Figure 79: Excavation supported by tie back walls

# Dry excavation using a tie back wall [ADV]

Create new project

## 6.1 Create new project

1. Start the Input program and select **Start a new project** from the **Quick start** dialog box.
2. In the **Project** tabsheet of the **Project properties** window, enter an appropriate title.
3. In the **Model** tabsheet keep the default options for **Model (Plane strain)**, and **Elements (15-Node)**.
4. Set the model **Contour** to  $x_{\min} = 0$  m,  $x_{\max} = 100$  m,  $y_{\min} = 0$  m,  $y_{\max} = 30$  m.
5. Keep the default values for units and the constants and press **OK** to close the **Project properties** window.

## 6.2 Define the soil stratigraphy

To define the soil stratigraphy:

1. Click the **Create borehole** button  and create a borehole at  $x = 0$ .  
The **Modify soil layers** window pops up.
2. Add three soil layers to the borehole. Locate the ground level at  $y = 30$  m by assigning 30 to the **Top** level of the uppermost layer. The bottom levels of the layers are located at 27, 15 and 0 m, respectively.
3. Set the **Head** to 23 m.  
The layer stratigraphy is shown in [Figure 80](#) (on page 103):

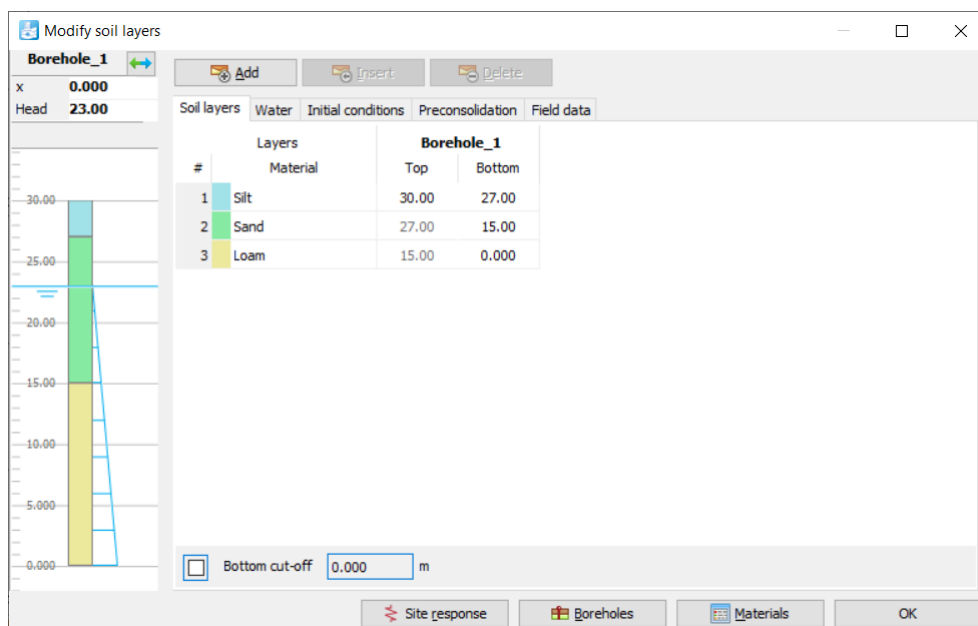

Figure 80: The Modify soil layers window

## Dry excavation using a tie back wall [ADV]

Create and assign material data sets

### 6.3 Create and assign material data sets

Three data sets need to be created. The materials have the following properties as shown in [Table 14](#) (on page 104):

**Table 14: Soil and interface properties**

Parameter	Name	Silt	Sand	Loam	Unit
<b>General</b>					
Soil model	Model	Hardening soil	Hardening soil	Hardening soil	-
Drainage type	Type	Drained	Drained	Drained	-
Unsaturated unit weight	$\gamma_{unsat}$	16	17	17	kN/m <sup>3</sup>
Saturated unit weight	$\gamma_{sat}$	20	20	19	kN/m <sup>3</sup>
<b>Mechanical</b>					
Secant stiffness in standard drained triaxial test	$E_{50}^{ref}$	$20 \cdot 10^3$	$30 \cdot 10^3$	$12 \cdot 10^3$	kN/m <sup>2</sup>
Tangent stiffness for primary oedometer loading	$E_{oed}^{ref}$	$20 \cdot 10^3$	$30 \cdot 10^3$	$8 \cdot 10^3$	kN/m <sup>2</sup>
Unloading / reloading stiffness	$E_{ur}^{ref}$	$60 \cdot 10^3$	$90 \cdot 10^3$	$36 \cdot 10^3$	kN/m <sup>2</sup>
Poisson's ratio	$\nu_{ur}$	0.2	0.2	0.2	-
Power for stress-level dependency of stiffness	$m$	0.5	0.5	0.8	-
Cohesion (constant)	$c'_{ref}$	1	0	5	kN/m <sup>2</sup>
Friction angle	$\varphi'$	30	34	29	°
Dilatancy angle	$\psi$	0	4	0	°
$K_0$ -value for normal consolidation	$K_0^{nc}$	0.5	0.4408	0.5152	-
<b>Groundwater</b>					
Classification type	-	USDA	USDA	USDA	-

## Dry excavation using a tie back wall [ADV]

Define the structural elements

Groundwater					
SWCC fitting method	-	Van Genuchten	Van Genuchten	Van Genuchten	-
Soil class	-	Silt	Sand	Loam	-
< 2 $\mu$ m	-	6.0	4.0	20.0	%
2 $\mu$ m - 50 $\mu$ m	-	87.0	4.0	40.0	%
50 $\mu$ m - 2mm	-	7.0	92.0	40.0	%
Flow parameters - Use defaults	-	From data set	From data set	From data set	-
Permeability in horizontal direction	$k_x$	0.5996	7.128	0.2497	m/day
Permeability in vertical direction	$k_y$	0.5996	7.128	0.2497	m/day
Interfaces					
Strength determination	-	Manual	Manual	Rigid	-
Interface reduction factor	$R_{inter}$	0.65	0.70	1.0	-
Consider gap closure	-	Yes	yes	yes	
Initial					
$K_0$ determination	-	Automatic	Automatic	Automatic	-
Pre-overburden pressure	$POP$	0	0	25	kN/m <sup>2</sup>
Over-consolidation ratio	$OCR$	1.0	1.0	1.0	-

1. Define three data sets for soil and interfaces with the parameters given in [Table 14](#) (on page 104).
2. Assign the material data sets to the corresponding soil layers ([Figure 80](#) (on page 103)).

## 6.4 Define the structural elements

The creation of diaphragm walls, excavation levels, ground anchor and surface load is described below.

1. Click the **Structures** tab to proceed with the input of structural elements in the **Structures mode** .

## Dry excavation using a tie back wall [ADV]

Define the structural elements

### 6.4.1 To define the diaphragm wall and interfaces:

A diaphragm wall with the following material properties as shown in [Table 15](#) (on page 106) has to be defined:

**Table 15: Material properties of the diaphragm wall (plate)**

Parameter	Name	Value	Unit
Material type	-	Elastic	-
Isotropic	-	Yes	-
Weight	$w$	8.3	kN/m/m
Prevent punching	-	Yes	-
Axial stiffness	$EA_1$	$12 \cdot 10^6$	kN/m
Bending stiffness	$EI$	$120 \cdot 10^3$	kNm <sup>2</sup> /m
Poisson's ratio	$\nu$	0.15	-

1. In the **Structures mode**, model the diaphragm walls as plates passing through (40 30) - (40 14) and (60 30) - (60 14).
2. Multi-select the plates in the model.
3. In the **Selection explorer** click on **Material**.

The view will change displaying a drop-down menu and a plus button next to it as shown in [Figure 81](#) (on page 106):

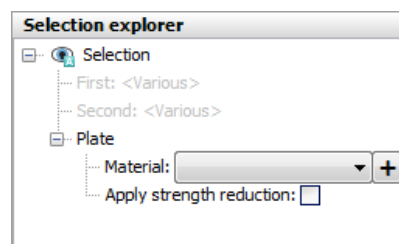

*Figure 81: Material assignment in the Selection explorer*

4. Click the Add button .  
A new empty material set is created for plates.
5. Define the material data set for the diaphragm walls according to the properties are listed in [Table 15](#) (on page 106). The concrete has a Young's modulus of 35 GN/m<sup>2</sup> and the wall is 0.35 m thick.
6. Assign positive and negative interfaces to the geometry lines created to represent the diaphragm walls.

## Dry excavation using a tie back wall [ADV]

Define the structural elements

---

### 6.4.2 To define the excavation levels:

The soil is excavated in three stages. The first excavation layer corresponds to the bottom of the silt layer and it is automatically created. To define the remaining excavation stages:

1. Define the second excavation phase by drawing a line through (40 23) and (60 23).
2. Define the third excavation phase by drawing a line through (40 20) and (60 20).

### 6.4.3 Defining the ground anchor

A ground anchor can be modelled by a combination of a node-to-node anchor and an embedded beam. The embedded beam simulates the grouted part of the anchor whereas the node-to-node anchor simulates the free length. In reality there is a complex three-dimensional state of stress around the grout body which cannot be simulated in a 2D model.

The coordinates of the anchor and grout body are listed in [Table 16](#) (on page 107), [Table 17](#) (on page 107) and [Table 18](#) (on page 108) and material properties of grout body are shown in [Table 19](#) (on page 108).

**Table 16: Node to node anchor coordinates**

Anchor location	Name	First point	Second point
Top	Left	(40 27)	(31 21)
	Right	(60 27)	(69 21)
Bottom	Left	(40 23)	(31 17)
	Right	(60 23)	(69 17)

**Table 17: Properties of the anchor rod (node-to-node anchor)**

Parameter	Name	Value	Unit
Material type	-	Elastic	-
Axial stiffness	$EA$	$500 \cdot 10^3$	kN
Out-of-plane spacing	$L_{spacing}$	2.5	m

## Dry excavation using a tie back wall [ADV]

Define the structural elements

**Table 18: Grout coordinates**

Anchor location	Name	First point	Second point
Top	Left	(31 21)	(28 19)
	Right	(69 21)	(72 19)
Bottom	Left	(31 17)	(28 15)
	Right	(69 17)	(72 15)

**Table 19: Properties of the grout body (embedded beam )**

Parameter	Name	Value	Unit
<b>General</b>			
Material type	-	Elastic	-
Unit weight	$\gamma$	0	kN/m <sup>3</sup>
<b>Mechanical</b>			
Pile spacing	$L_{spacing}$	2.5	m
Beam type	-	Predefined	-
Predefined beam type	-	Solid circular beam	-
Diameter	$D$	0.3	m
Stiffness	$E$	$7.07 \cdot 10^6$	kN/m <sup>2</sup>
Axial Skin resistance	Distribution	Linear	-
	$T_{skin, start, max}$	400	kN/m
	$T_{skin, end, max}$	400	kN/m
Lateral resistance	Lateral resistance	Unlimited	-
Base resistance	$F_{max}$	0	kN
Interface stiffness factor	Default values	Yes	-

1. Define the node-to-node anchors  according to [Table 16](#) (on page 107).
2. Create an **Anchor** material data set according to the parameters specified in [Table 17](#) (on page 107).
3. Multi-select the anchors in the drawing area. Assign the material data set by selecting the corresponding option in the **Material** drop-down menu in the **Selection explorer**.

## Dry excavation using a tie back wall [ADV]

Generate the mesh

4. Define the grout body using the **Embedded beam** button  according to [Table 18](#) (on page 108).
5. Create the **Grout** material data set according to the parameters specified in [Table 19](#) (on page 108) and assign it to the grout body.
6. Set the **Behaviour** of the embedded beam to **Grout body** as shown in [Figure 82](#) (on page 109).

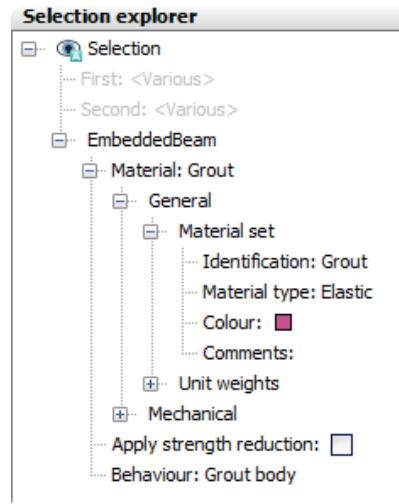



Figure 82: Embedded beam in the Selection explorer

The connection with the anchor will be automatically established.

7. Multi-select (keep **<Ctrl>** pressed while selecting) the top node-to-node anchors and embedded beams. Right-click on the selected region and select the **Group** option in the context menu.
8. In the **Model explorer** expand the **Groups subtree**.  
Note that a group is created composed of the elements of the top ground anchors.
9. Click on **Group\_1** in the **Model explorer** and type a new name (e.g GroundAnchor\_Top).
10. Follow the same steps to create a group and to rename the bottom ground anchors.

Although the precise stress state and interaction with the soil cannot be modelled with this 2D model, it is possible in this way to estimate the stress distribution, the deformations and the stability of the structure on a global level, assuming that the grout body does not slip relative to the soil. With this model it is certainly not possible to evaluate the pullout force of the ground anchor.

### 6.4.4 To define the distributed load:

1. Create a line load  between (28 30) and (38 30).



## 6.5 Generate the mesh

In order to generate the mesh, follow these steps:



## Dry excavation using a tie back wall [ADV]

Define and perform the calculation

1. Proceed to the **Mesh mode**.
2. Click the **Generate mesh** button  in the side toolbar. Use the default option for the **Element distribution** parameter (**Medium**).
3. Click the **View mesh** button  to view the mesh as shown in [Figure 83](#) (on page 110).

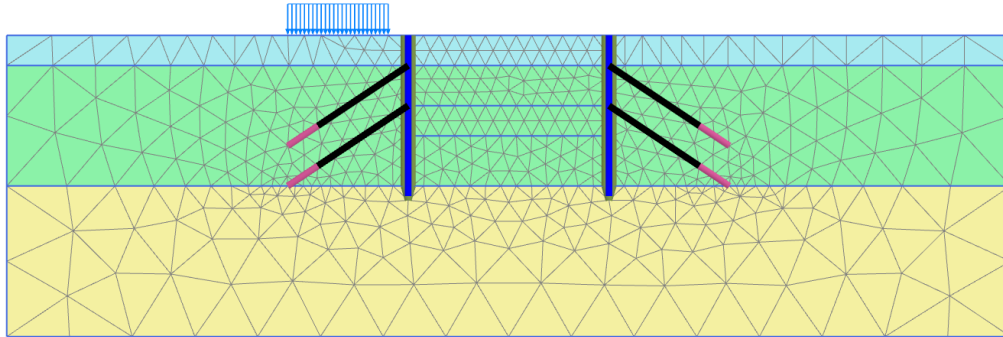

Figure 83: The generated mesh

## 6.6 Define and perform the calculation

The calculation of this project consists of six phases. In the initial phase (Phase 0), the initial stresses are generated. In Phase 1, the walls are constructed and the surface loads are activated. In Phase 2, the first 3 m of the pit is excavated without connection of anchors to the wall. At this depth the excavation remains dry. In Phase 3, the first anchor is installed and pre-stressed. Phase 4 involves further excavation to a depth of 7 m. At this depth the excavation still remains dry. In Phase 5, the second anchor is installed and pre-stressed. Phase 6 is a further excavation to the final depth of 10 m including the dewatering of the excavation.

Before defining the calculation phases, the water levels to be considered in the calculation can be defined in the **Flow conditions** mode. The water level is lowered in the final excavation phase. At the side boundaries, the groundwater head remains at a level of 23.0 m. The bottom boundary of the problem should be closed. The flow of groundwater is triggered by the fact that the pit is pumped dry. At the bottom of the excavation the water pressure is zero, which means that the groundwater head is equal to the vertical level (head = 20.0 m). This condition can be met by drawing a new general phreatic level and performing a groundwater flow calculation. Activating the interfaces during the groundwater flow calculation prevents flow through the wall.

### 6.6.1 Initial phase

The initial stress field is generated by means of the **K0 procedure** using the default  $K_0$ -values in all clusters defined automatically by the program.

1. Proceed to the **Staged construction mode**.

## Dry excavation using a tie back wall [ADV]

Define and perform the calculation

- Initially, all structural components and loads are inactive. Hence, make sure that the plates, the node-to-node anchors, the embedded beam rows and the surface loads are deactivated.
- In the **Phases explorer** double-click the initial phase. The default parameters for the initial phase will be used. The **Phreatic** option is selected as **Pore pressure calculation type**. Note that when the pore pressures are generated by phreatic level, the full geometry of the defined phreatic level is used to generate the pore pressures.
- Click **OK** to close the **Phases** window.
- In the **Model explorer** expand the **Model conditions** subtree.
- Expand the **Water** subtree.  
The water level created according to the head value specified in the borehole, (**BoreholeWaterLevel\_1**), is automatically assigned to **GlobalWaterLevel**.
- The model for initial phase is shown in [Figure 84](#) (on page 111).

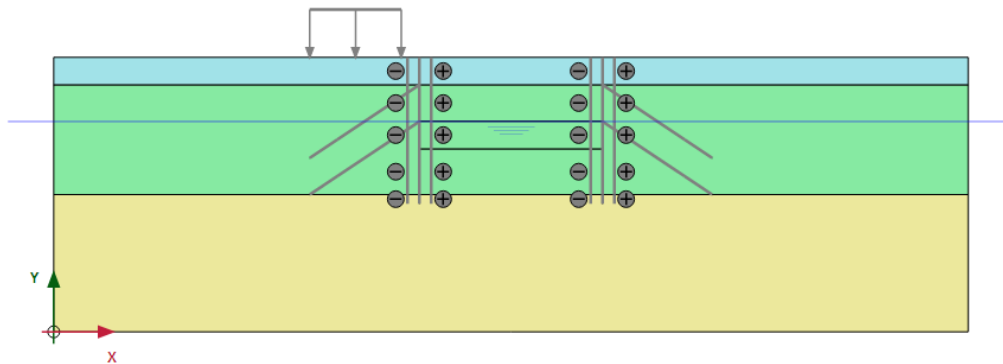



Figure 84: Configuration of the initial phase

### 6.6.2 Phase 1: Activation of wall and load

- Click the **Add phase** button  to create a new phase.
- In the **Staged constructions mode** activate all walls and interfaces by clicking on the checkbox in front of them in the **Model explorer**.  
The active elements in the project are indicated by a green check mark.
- Activate the distributed load.
- After selecting the line load assign a value of -10 to  $q_{y,start,ref}$  in the **Selection explorer** shown in [Figure 85](#) (on page 111):

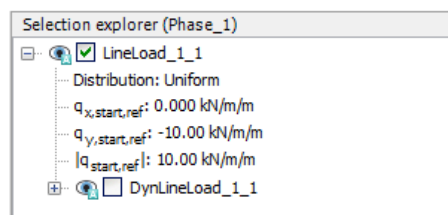

Figure 85: Line load in the Selection explorer

## Dry excavation using a tie back wall [ADV]

Define and perform the calculation

The model for the phase 1 in the **Staged construction mode** is displayed in [Figure 86](#) (on page 112):

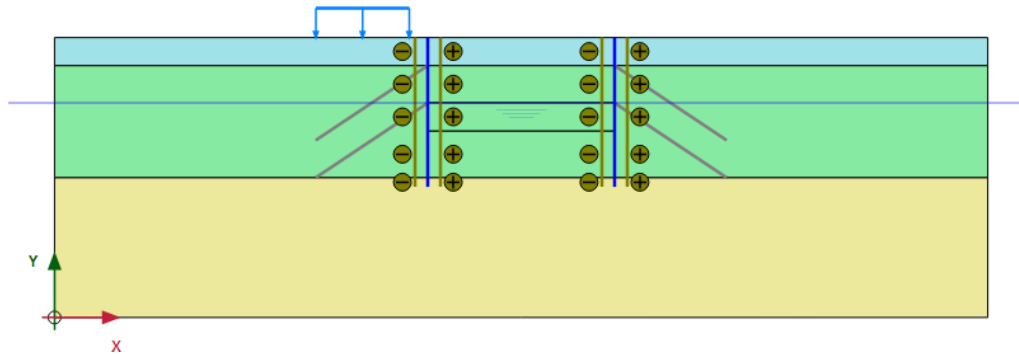

Figure 86: Configuration of Phase 1 in the Staged construction mode

### 6.6.3 Phase 2: First excavation

1. Click the **Add phase** button  in the **Phases explorer** to add a new phase.
2. In the **Staged construction mode** de-activate the upper cluster of the excavation

The model for the first excavation phase is shown in [Figure 87](#) (on page 112):

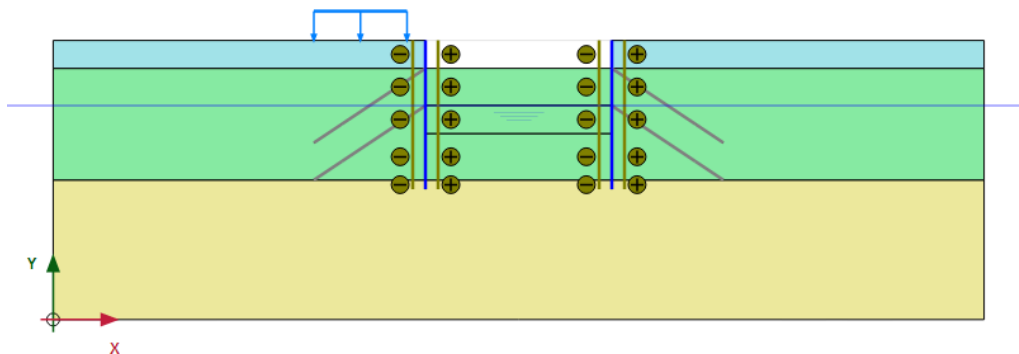



Figure 87: Configuration of Phase 2 in the Staged construction mode

### 6.6.4 Phase 3: First anchor row

1. Click the **Add phase** button  in the **Phases explorer**.
2. Activate the upper ground anchors by clicking on the checkbox in front of **GroundAnchors\_Top** under the **Groups** subtree in the **Model explorer**.
3. Multi-select the top node-to-node anchors.
4. In the **Selection explorer** set the **Adjust prestress** parameter to **True** and assign a pre-stress force of 500 kN.

## Dry excavation using a tie back wall [ADV]

Define and perform the calculation

**Note:** A pre-stress force is exactly matched at the end of a finished staged construction calculation and turned into an anchor force. In successive calculation phases the force is considered to be just an anchor force and can therefore further increase or decrease, depending on the development of the surrounding stresses and forces.

The model for the phase 3 in the Staged construction mode is shown in [Figure 88](#) (on page 113):

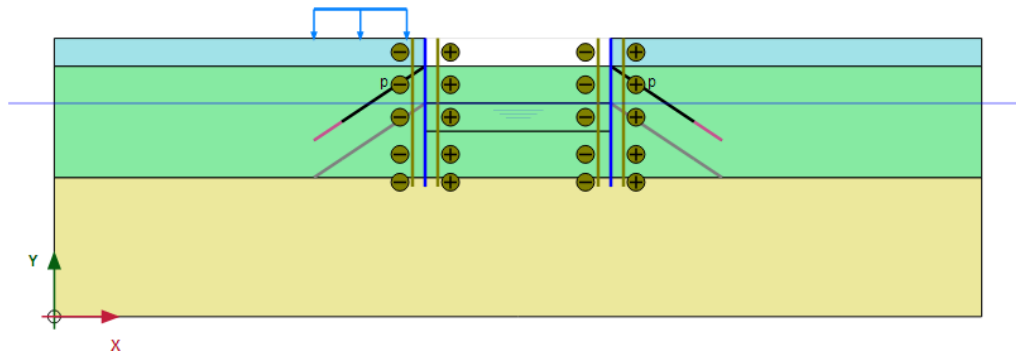



Figure 88: Configuration of Phase 3 in the Staged construction mode

### 6.6.5 Phase 4: Second excavation

1. Click the **Add phase** button  to add a new phase.
2. Deactivate the second cluster of the excavation.

The model for the phase 4 in the **Staged construction** mode is displayed in [Figure 89](#) (on page 113):

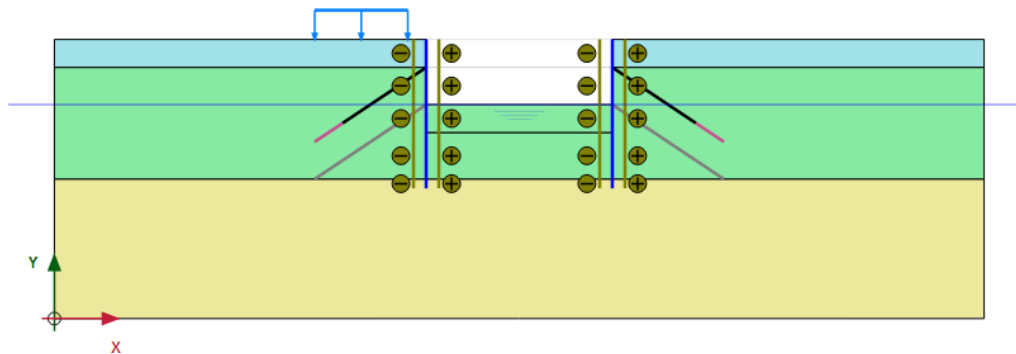



Figure 89: Configuration of Phase 4 in the Staged construction mode

Note that the anchors are not pre-stressed anymore.

## Dry excavation using a tie back wall [ADV]

Define and perform the calculation

### 6.6.6 Phase 5: Second anchor row

1. Click the **Add phase** button  to add a new phase.
2. Activate the lower ground anchors.
3. Select the bottom node-to-node anchors.
4. In the **Selection explorer** set the **Adjust prestress** parameter to **True** and assign a pre-stress force of 1000 kN.

The model for the phase 5 in the **Staged construction** mode is displayed in [Figure 90](#) (on page 114):

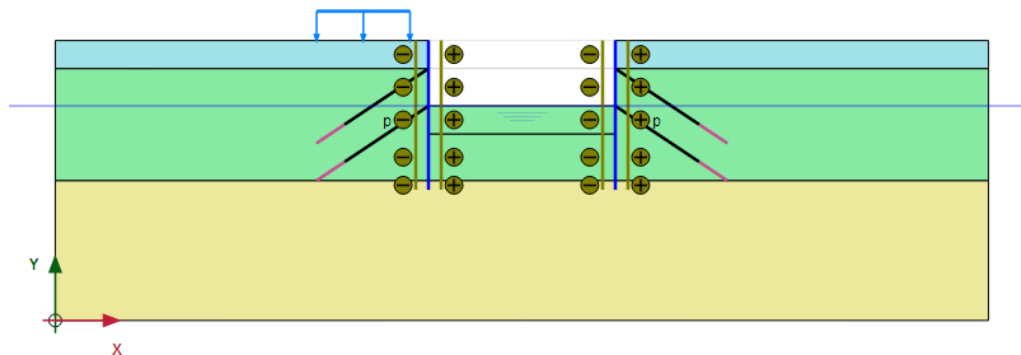





Figure 90: Configuration of Phase 5 in the Staged construction mode

### 6.6.7 Phase 6: Final excavation

1. Click the **Add phase** button  to add a new phase.
2. In the **Phases** window, within **General > Pore pressure calculation type** select the **Steady state groundwater flow** option . The default values of the remaining parameters are valid.
3. Deactivate the third cluster of the excavation.
4. Click the **Flow conditions** tab to display the corresponding mode.
5. In the **Model explorer** expand the **Attributes library**.
6. Expand the **Water levels** subtree.
7. Click the **Create water level** button  in the side toolbar and draw a new phreatic level. Start at (0 23) and draw the phreatic level through (40 20), (60 20) and end in (100 23).
8. In the **Model explorer** expand the **User water levels** subtree. Click on **UserWaterLevel\_1** and type LoweredWaterLevel1 to rename the water level created in the **Flow conditions** mode as shown in [Figure 91](#) (on page 115).

## Dry excavation using a tie back wall [ADV]

Define and perform the calculation

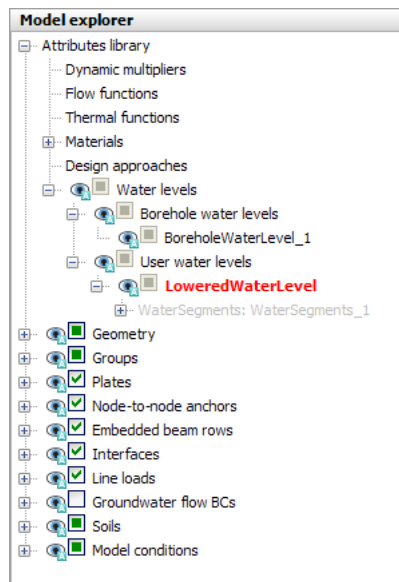

Figure 91: Water levels in the Model explorer

9. In the **Model explorer** expand **Model conditions** > **GroundwaterFlow**. The default boundary conditions are valid which is shown in [Figure 92](#) (on page 115).

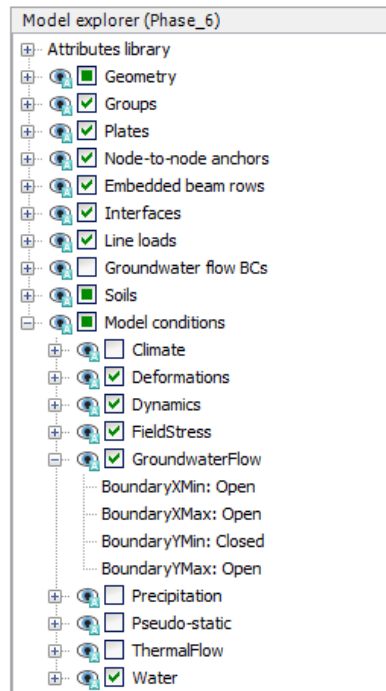

Figure 92: The GroundwaterFlow subtree under the Model conditions in the Model explorer

10. In the **Water** subtree assign the **LoweredWaterLevel** to **GlobalWaterLevel**.

The model and the defined water levels are displayed in [Figure 93](#) (on page 116):

## Dry excavation using a tie back wall [ADV]

### Results

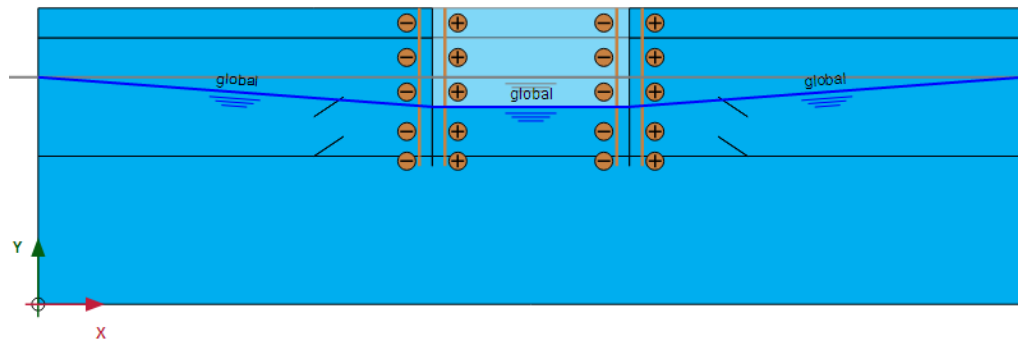





Figure 93: Configuration of Phase 6 in the Flow conditions mode

**Note:** Note that for **Groundwater flow** (steady or transient) the intersection points of the water level with the active model boundaries are important. The program calculates flow boundary conditions in terms of a groundwater head corresponding to the water level. The 'internal' part of the water level is not used and will be replaced by the phreatic level resulting from the groundwater flow calculation. Hence, the water level tool is just a convenient tool to create boundary conditions for a flow calculation.

### 6.6.8 Execute the calculation

1. Click the **Select points for curves** button  in the side toolbar.
2. Select some characteristic points for curves (for example the connection points of the ground anchors on the diaphragm wall, such as (40 27) and (40 23)).
3. Click the **Calculate** button  to calculate the project.
4. After the calculation has finished, save the project by clicking the Save button .

## 6.7 Results

The deformed meshes at the end of calculation phase 2 to phase 6 are shown in [Figure 94](#) (on page 117), [Figure 95](#) (on page 117), [Figure 96](#) (on page 117), [Figure 97](#) (on page 118) and [Figure 98](#) (on page 118):

# Dry excavation using a tie back wall [ADV]

Results

---

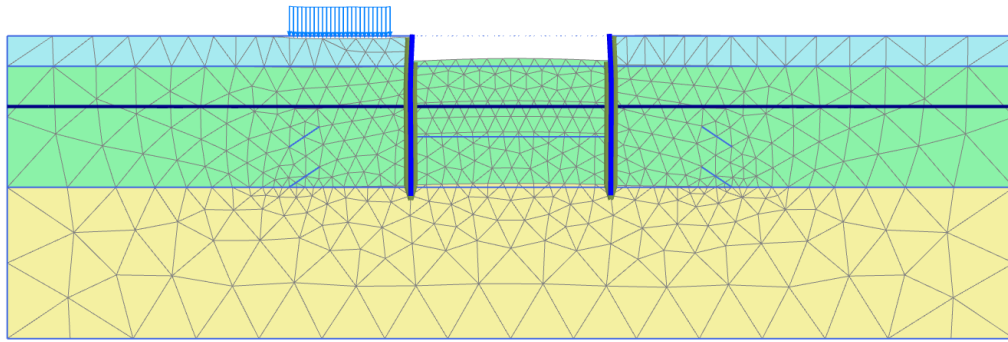

Figure 94: Deformed mesh (scaled up 50.0 times) - Phase 2

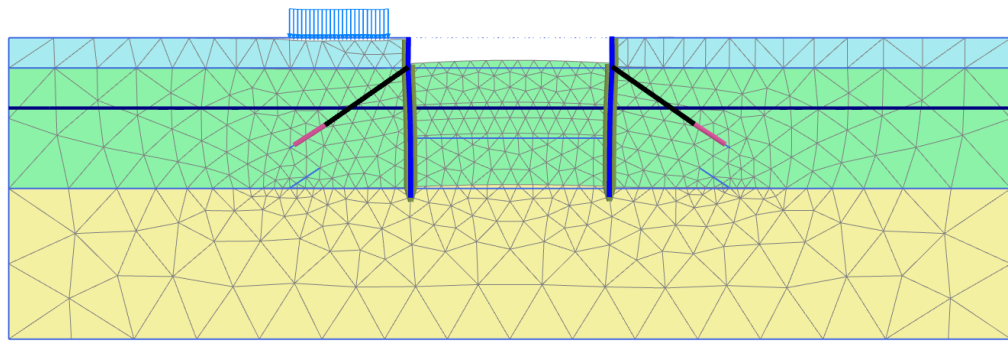

Figure 95: Deformed mesh (scaled up 50.0 times) - Phase 3

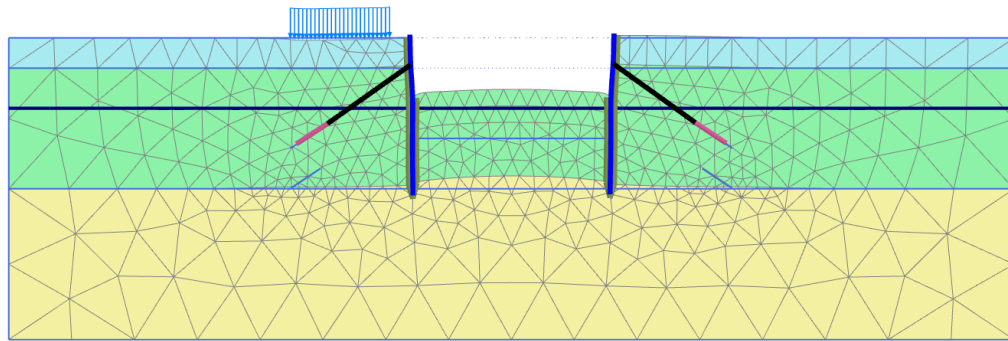

Figure 96: Deformed mesh (scaled up 50.0 times) - Phase 4



# Dry excavation using a tie back wall [ADV]

Results

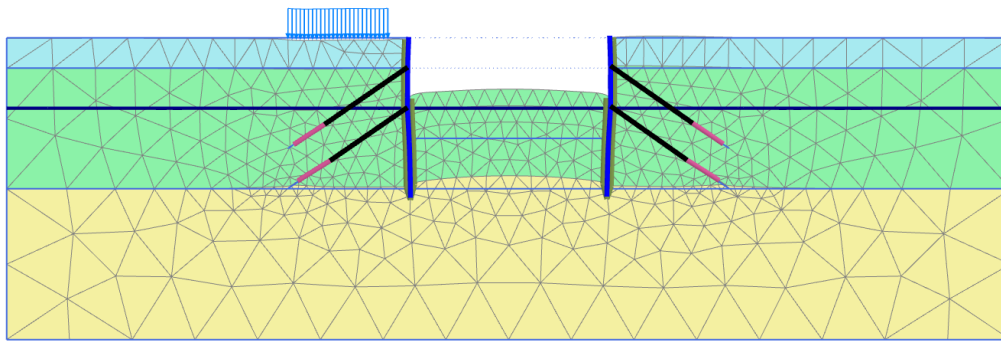

Figure 97: Deformed mesh (scaled up 50.0 times) - Phase 5

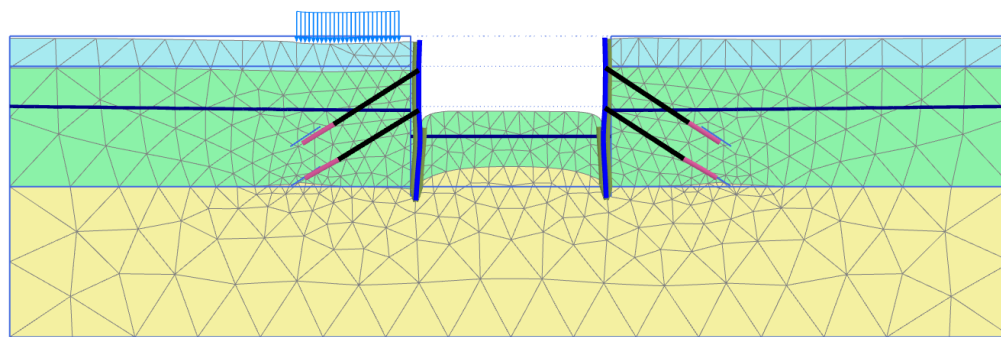

Figure 98: Deformed mesh (scaled up 50.0 times) - Final phase

Figure 99 (on page 118) shows the effective principal stresses in the final situation. The passive stress state beneath the bottom of the excavation is clearly visible. It can also be seen that there are stress concentrations around the grout anchors.

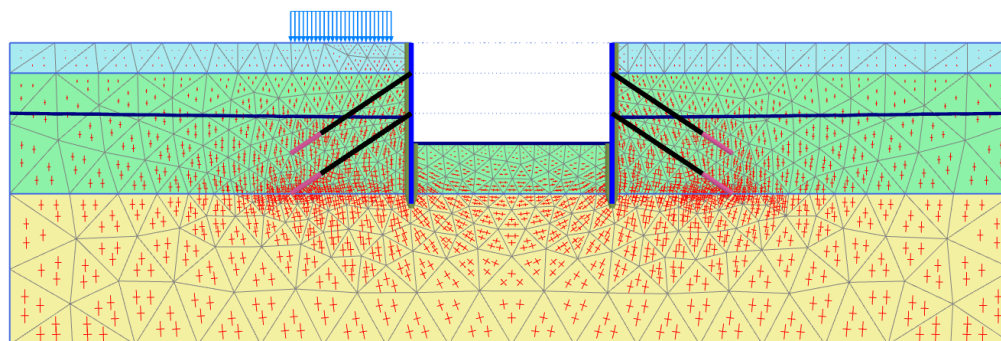

Figure 99: Principal effective stresses (final stage)

Figure 100 (on page 119) shows the bending moments in the diaphragm walls in the final state. The two dips in the line of moments are caused by the anchor forces.

## Dry excavation using a tie back wall [ADV]

Results

---

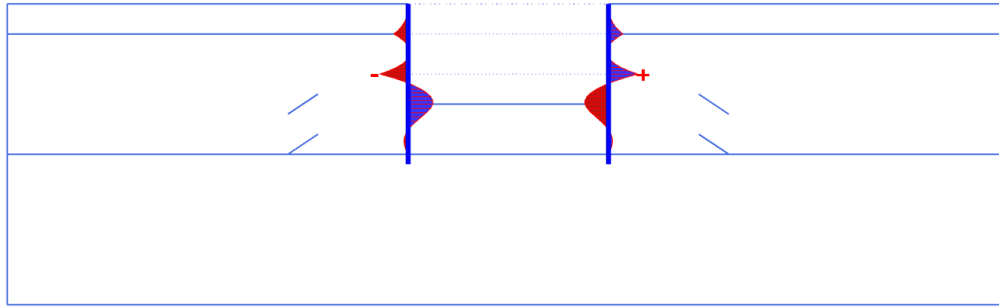

*Figure 100: Bending moments in the diaphragm walls in the final stage*

The anchor force can be viewed by double clicking the anchor. When doing this for the results of the third and the fifth calculation phase, it can be checked that the anchor force is indeed equal to the specified pre-stress force in the calculation phase they are activated. In the following phases this value might change due to the changes in the model.