

# MOSS User Manual



surface modelling by compu

Published by:

MOSS Systems Limited,  
MOSS House  
North Heath Lane  
Horsham  
West Sussex RH12 5QE  
England

Telephone 01403 259511  
International +44 1403 259511  
Fax 01403 211493

MOSS Modelling Systems.

©Copyright 1997 MOSS Systems Limited

All rights reserved.

No part of this publication may be reproduced in any form without the prior written permission of the publisher.

Issue 1      first published January 1975  
Issue 7      updated November 1987 for Software Release 7  
Issue 8      updated January 1990 for Software Release 8  
Issue 9      re-published April 1991 for Software Release 9  
Issue 9.1    supplement published September 1991 for Software Release 9.1  
Issue 9.2    re-published June 1993 for Software Release 9.2  
Issue 10.0   re-published December 1993 for Software Release 10.0  
Issue 10.1   re-published March 1994 for Software Release 10.1  
Issue 10.2   re-published September 1994 for Software Release 10.2  
Issue 10.3   re-published June 1995 for Software Release 10.3  
Issue 10.4   re-published March 1996 for Software Release 10.4  
Issue 10.5   re-published January 1997 for Software Release 10.5

ISBN 0 86260 009 X

### Disclaimer

MOSS Systems Limited are continually improving the quality of their software. Therefore they reserve the right to make changes both to the software and the documentation without notice.

The information in this publication is as accurate as possible but MOSS Systems cannot give any warranty that the software is free from errors or that it will meet every requirement of all users. It is the user's responsibility to satisfy himself that the software is suitable for the purpose for which it was purchased.

The software described in this publication is subject to a licensing agreement and may only be used in accordance with the terms of that agreement.

### **Foreword**

MOSS Modelling Systems, a system of computer programs described in this manual, was conceived in the early 1970's by a group of engineers and computer specialists working in local government in the UK. MOSS was launched publicly in 1975 and as a result of interest shown, the MOSS Consortium consisting of the County Councils of Durham, Northampton and West Sussex, was formed to manage the distribution and marketing of the system.

The ownership of the system was subsequently transferred from the MOSS Consortium to the company MOSS Systems Limited in 1987.

### **Acknowledgements**

A number of contributions throughout both the public and private sectors worldwide have assisted in the development of the system. In particular the original enthusiasm and encouragement of the MOSS Consortium is acknowledged.

Special thanks are also due to the current staff of MOSS Systems Limited all of whom are involved in the continuing development of the system.

### **Manual Revisions**

#### **June 1993 for Version 9.2**

Updated and republished. First publication in electronic form.

#### **December 1993 for Version 10.0**

Updated and republished.

#### **July 1994 for Version 10.2**

Updated and republished.

#### **June 1995 for Version 10.3**

Updated and republished.

#### **March 1996 for Version 10.4**

Updated and republished.

#### **January 1997 for Version 10.5**

Updated and republished.

# Contents

<b>Introduction</b>	<b>1-1</b>
Structure	1-1
Format and conventions	1-4
The MOSS documentation set	1-5
<b>Help on HELP</b>	<b>1-7</b>
<b>Throughout MOSS</b>	<b>2-1</b>
MOSS's modes	2-1
Initial entry to MOSS	2-3
<b>Graphics</b>	<b>2-4</b>
Grouping of major options	2-4
Overview	2-5
The interactive graphics screen	2-7
The static menu	2-9
The scrolling menu	2-18
The selection method menu	2-19
The dynamic menu	2-20
<b>Linemode</b>	<b>2-21</b>
Command structure	2-21
Macros	2-24
<b>Models and the DPF</b>	<b>2-24</b>
Definitions	2-24
Model names and types	2-26
String labelling	2-27
Standard Point Reference Data (SPRD)	2-30
String types	2-31
<b>General information</b>	<b>2-35</b>
Keyboard entry – case sensitivity	2-35
Curve fitting	2-35
Discontinuities	2-37
Negative coordinates	2-38
Graphics selection methods	2-40
The LOG file	2-56
The parameter file	2-57
Error handling	2-57

<b>General options</b>	<b>2-58</b>
Introduction	2-58
Major option ALIAS	2-59
Major option ARCHIVE	2-60
Major option ASSIGN	2-61
Major option COMPRESS	2-62
Major option CREATE	2-64
Major option DELETE	2-65
Major option DOCUMENT	2-66
Major option DUMP	2-67
Major option ERASE	2-68
Major option FINISH	2-70
Major option FREE	2-70
Major option HELP	2-71
Major option INPUT	2-72
Major option JOURNAL	2-74
Major option LIST	2-75
Major option MOSS	2-76
Major option NEWFILE	2-76
Major option OUTPUT	2-77
Major option OVERWRITE	2-78
Major option RENAME	2-79
Major option REPLAY	2-80
Major option RESTORE	2-83
Major option RETRIEVE	2-84
Major option SECURE	2-85
SUBSYSTEM	2-86
<b>Global minor options</b>	<b>2-87</b>
Minor option 000   Add log comments	2-87
Minor option 001   Provide supplementary information	2-88
Minor option 003   Define the order of items	2-89
Minor option 017   Define system parameters	2-89
Minor option 018   Define linear units	2-96
Minor option 019   Define string masking	2-97
Minor option 900   Invoke a macro option	2-99
Minor option 999   End a major option	2-99
<b>Drawing</b>	<b>3-1</b>
Concepts of drawing production	3-2
Graphics facilities in MOSS	3-6
<b>Major option NEWDPF</b>	<b>3-12</b>
<b>Major option NEWRPF</b>	<b>3-13</b>

<b>DRAW macros</b>	<b>3-15</b>
Access to DRAW using MACROS	3-17
Macro PLANDRAW	3-19
Macro PLANLINE	3-22
Macro LONGDRAW	3-37
Macro LONGLINE	3-40
Macro SECTDRAW	3-46
Macro SECTLINE	3-49
Macro SURVDRAW	3-55
<b>Drawing concepts</b>	<b>3-58</b>
<b>Major option DRAW</b>	<b>3-77</b>
String dimensions	3-82
Access to major option DRAW	3-85
DRAW Minor options 701 - 734	3-87
Minor option 711 Draw schematic line (type 1)	3-101
Minor option 721 Annotation of schematic (type 1)	3-102
Minor option 731 Ordinates for schematic diagrams (type 1)	3-103
Minor option 712 Vertical schematic line work (type 2)	3-111
Minor option 722 Annotation of vertical schematic (type 2)	3-112
Minor option 732 Ordinates for vertical annotation (type 2)	3-113
Minor option 713 Vertical schematic line work (type 3)	3-119
Minor option 723 Annotation for vertical schematic (type 3)	3-122
Minor option 733 Ordinates for annotation (type 3)	3-123
Minor option 714 Vertical schematic linework (type 4)	3-126
Minor option 724 Annotation for circular schematic (type 4)	3-127
Minor option 734 Key diagram for circular schematic (type 4)	3-128
Minor option 800 Define sheet details	3-132
Minor option 801 Invoke overplotting	3-135
Create new sheet	3-140
Minor option 802 Define sheet margins	3-140
Minor option 803 Define coordinate relationship	3-144
Define a boundary	3-150
Minor option 804 Define part of model	3-151
Minor option 805 Line type and colour	3-161
Minor option 806 Text type and colour	3-162
Minor option 807 Fill area characteristics	3-162
Minor option 808 Set current text style	3-166
Minor option 809 Geometry string annotation	3-169
Minor option 810 Set current line style	3-174
Minor option 812 Set curve fitting	3-178
Minor option 814/815 Create an object	3-178
Minor option 817 Erase element	3-179
Minor option 818 Set clip status	3-180

## CONTENTS

---

Minor option 819	Set clip parameters	3-181
Minor option 821	Add a drawing frame	3-183
Minor option 822	Add a grid	3-185
Minor option 825	Draw selected strings	3-189
Minor option 825	Draw contour strings	3-192
Minor option 825	Draw null/zero levels	3-195
Minor option 826	Draw string or set of strings	3-196
Minor option 827	Draw triangulation	3-199
Minor option 828	Draw drainage network	3-200
Minor option 829	Draw drainage section	3-204
Minor option 830	Draw text strings	3-206
Minor option 831	Draw raster backcloth	3-207
Minor option 845	Define annotation area	3-210
Minor option 846	Draw axis annotation	3-214
Minor option 847	Draw text in a box area	3-218
Minor option 848	Define a text variable	3-219
Minor option 849	Draw ordinates from an axis to a string	3-221
Minor option 853	Annotate crossfall	3-226
Minor option 854	Annotate vertical intersection points	3-227
Minor option 856	Draw cadastral symbols	3-233
Minor option 857	Annotate points with text	3-237
Minor option 858	Information along a string	3-239
Minor option 859	Information at points	3-242
Minor option 860	Pips	3-250
Minor option 861	Macrosymbol at string points	3-251
Minor option 862	Scaled macrosymbol at points	3-252
Minor option 863	Standard symbol points	3-254
Minor option 864	Between string points	3-256
Minor option 865	Point sequence numbers	3-259
Minor option 866	Chainages on 1 side only	3-260
Minor option 867	Chainages on both sides	3-261
Minor option 868	Spot levels	3-262
Minor option 869	String dimension content	3-265
Minor option 870	Fill triangulation	3-270
Minor option 875, 876	Hatch between two strings	3-271
Minor option 877, 878	Hatch between two lines	3-272
Minor option 879	Fill area inside a boundary string	3-273
	Draw using a macro	3-277
<b>ENHANCE macros</b>		<b>3-279</b>
	The use of macro commands	3-279
	Macro LINETEXT	3-280
	Macros to draw circles and arcs	3-282
<b>Major option ENHANCE</b>		<b>3-287</b>
	Selection of drawing environment	3-287



Enhancement options	3-288
Detailed description of minor options	3-291
Access to major option ENHANCE	3-292
Minor option 880 Define drawing sheets	3-293
Minor option 821, 881 Frames and meshes	3-294
Minor option 882 Lines / polylines	3-298
Minor option 883, 884 Text / polytext	3-303
Minor option 886 Macrosymbols	3-310
Minor option 887 Standard symbols	3-311
Minor option 888 Boxes	3-312
Minor option 889 Circles	3-313
Minor option 889, 890 Arcs	3-316
Minor option 894 Hatch inside a boundary element	3-321
Minor option 895 Hatch between two elements	3-322
Minor option 896, 897 Hatch between two lines	3-323
Minor option 899 Report on the installation defaults	3-324
<b>Major option CLIP</b>	<b>3-326</b>
<b>Major option LAYOUT</b>	<b>3-335</b>
Access to major option LAYOUT	3-337
Define sheet properties	3-337
Sheet position method	3-338
Modify a set of sheets	3-340
Create DRAW data/strings	3-340
<b>General options</b>	<b>4-1</b>
Major option EDIT	4-1
Access to major option EDIT	4-2
Minor option 002 Create a text string	4-3
Minor option 002 Create a contour string	4-5
Minor option 004 Delete an entire string	4-6
Minor option 005 Delete part of a string	4-7
Minor option 006 Add one discontinuity	4-12
Minor option 007 Add some discontinuities	4-13
Minor option 008 Create a string	4-14
Minor option 009 Create a boundary string	4-22
Minor option 010 Create a string (between intersection points)	4-28
Minor option 012 Join two strings	4-30
Minor option 020 Change string label / Change contour level	4-32
Minor option 021 Change any string dimension	4-34
Minor option 022 Change string dimension 1/2/3	4-36
Minor option 023 Add point before a point	4-37
Minor option 024 Add point after a point	4-39
Minor option 025 Delete a point	4-41

Minor option 026	Insert a point	4-42
Minor option 027	Convert to 6D M-string	4-48
Minor option 028	Create string with extra points	4-50
Minor option 029	Generate M-string from a geometry string	4-52
Minor option 030	Change a series of labels	4-55
Minor option 031	Delete a series of strings	4-55
Minor option 032	Delete loops / tail ends	4-56
Minor option 033	Change string sub-reference	4-61
Minor option 035/036	Add slope signature string	4-62
Minor option 037	Create cadastre string	4-65
Minor option 038	Change cadastre point	4-66
	Change symbol reference bearing	4-67
<b>Major option REPORT</b>		<b>4-69</b>
	Access to major option REPORT	4-69
Minor option 980	Geometry information	4-70
Minor option 982	Triangles	4-74
Minor option 984	Piste format information	4-76
Minor option 985/986	Report section strings in a stylised format	4-79
Minor option 985/983	Report section strings in (PISTE) format	4-80
Minor option 987	Check record pointers	4-82
Minor option 988	Check for loops in string	4-83
Minor option 989	Model file records used	4-84
Minor option 990	Models	4-85
Minor option 991	Strings	4-86
Minor option 992	String details	4-88
Minor option 993	String details - user defined format	4-91
Minor option 994	Section strings	4-93
Minor option 995	Distance and bearing (of line)	4-96
Minor option 996	Normals to a string Distance and bearing (of normal)	4-98
Minor option 997	Intersection of 2 strings	4-102
Minor option 998	Normals from a string (Normal intersections)	4-103
<b>Major option COPY</b>		<b>4-106</b>
	Access to major option COPY	4-107
	Models for COPY	4-108
	Simple move/copy	4-110
Minor option 059	Transformations	4-113
Minor option 060	Copy strings	4-124
Minor option 061	Move strings	4-126
Minor option 064	Copy strings with curve fitting	4-127
Minor option 065	Move strings with curve fitting	4-129
Minor option 066	Copy triangulation string	4-131
<b>Major option AREA</b>		<b>4-132</b>

Access to major option AREA	4-134
Minor option 040 Within boundary string	4-134
Minor option 041 Between two strings	4-136
Minor option 042 Two intersecting boundaries	4-138
Minor option 043 Slope between two strings	4-140
Minor option 045 Triangulation area	4-142
Minor option 046/47/48 Section based area	4-143
<b>Survey</b>	<b>5-1</b>
Introduction	5-1
<b>Major option IDIGIT</b>	<b>5-4</b>
Major option IDIGIT	5-7
Access to major option IDIGIT	5-8
Review and modify tolerances	5-9
Review and modify environment defaults	5-10
Select transformation points	5-11
Select block corner points	5-12
Select drawing parameters	5-13
Digitise strings	5-13
Edit current string	5-15
Locate puck position	5-16
Terminate sheet	5-17
<b>Major option SURVEY</b>	<b>5-18</b>
Introduction	5-18
Principles of creating surveys using MOSS	5-20
How MOSS processes the survey data	5-31
Instrument set up	5-34
Applying correction factors	5-36
Survey stations	5-38
String labels	5-55
Recording points	5-60
Recording features in strings	5-73
Recording circular and rectangular features	5-77
Macro SURVDRAW	5-83
Major option SURVEY	5-84
Minor option 180 Add, amend or delete station	5-87
Minor option 189 Survey constants record	5-87
Minor option 190 Theodolite and Traversing constants record	5-88
Minor option 200 Instrument set up record	5-89
Minor option 201/202 Observation point on straight/curve	5-90
Minor option 203 Offset strings	5-94
<b>Transformation</b>	<b>5-95</b>

Minor option 189	Survey constants record	5-97
Minor option 199	Least squares transformation	5-97
<b>Survey accuracy validation</b>		<b>5-99</b>
Theory		5-99
Minor option 998	Evaluation of level and lateral differences	5-104
<b>Major option SETOUT</b>		<b>5-109</b>
Minor option 180	Add, amend, or delete reference stations	5-109
Minor option 181	Setting out a string by deflection angles	5-111
Minor option 182	Setting out a string by intersecting rays	5-116
Minor option 183	Setting out by offsets	5-119
<b>Interactive alignment</b>		<b>6-1</b>
Introduction		6-1
Alignment design		6-2
Feature design		6-2
The ALIGNMENT design sequence		6-5
<b>Major option ALIGNMENT</b>		<b>6-7</b>
Access to major option ALIGNMENT		6-7
ALIGNMENT main menu		6-8
Create M-string		6-9
Create data output		6-11
Drawing management		6-13
Alignment management		6-14
Status		6-20
Superelevation design		6-21
Crossfall parameters		6-22
Display parameters		6-24
Apply crossfall		6-24
All/sequential crossfall		6-26
Apply crossfall: arc		6-27
Apply crossfall: straight		6-28
Apply crossfall: C-curve		6-28
Apply crossfall: S-curve		6-30
Crossfall in error: all		6-31
Crossfall in error: single		6-32
Crossfall review		6-33
<b>Horizontal design</b>		<b>6-34</b>
Introduction		6-34
Continue alignments		6-34
Horizontal design		6-35

<b>Horizontal element method</b>	<b>6-38</b>
Introduction	6-38
Element alignment	6-39
Define fix straight	6-41
Define fix arc	6-42
Copy element	6-45
Define float straight	6-46
Define float arc	6-47
Define free straight	6-49
Define free arc	6-50
Add straight	6-51
Add arc	6-53
Special geometry	6-54
Fix to fix	6-55
Create three centre curve	6-58
Alignment review	6-62
Clearance checking	6-63
Edit alignment	6-64
Display parameters	6-74
Design parameters	6-76
<b>Horizontal IP method</b>	<b>6-81</b>
IP alignment	6-81
Construct IP	6-83
Edit alignment	6-83
Insert arc	6-85
Display parameters	6-88
Design parameters	6-89
<b>Horizontal spline method</b>	<b>6-90</b>
Introduction	6-90
Spline symbols	6-90
Spline alignment	6-91
Locate point(s)	6-92
Insert point(s)	6-94
Respecify point	6-95
Delete point	6-96
Alignment review	6-96
Display parameters	6-97
Design parameters	6-98
<b>Vertical design</b>	<b>6-100</b>
Introduction	6-100
Backcloth drawing	6-100
Data entry	6-102

Analysis	6-103
Begin vertical design	6-103
Intersect annotation	6-104
Amend/delete vertical alignment	6-109
Ground profile	6-112
Profile details	6-113
Profile parameters	6-114
Vertical design	6-115
<b>Vertical element method</b>	<b>6-116</b>
Introduction	6-116
Element alignment	6-117
Free curve - defined length	6-118
Edit alignment	6-119
Special geometry	6-128
Alignment review	6-129
Display parameters	6-130
Design parameters	6-131
<b>Vertical IP method</b>	<b>6-133</b>
Introduction	6-133
IP alignment	6-133
Curve in IP alignment	6-134
Display parameters	6-135
Design parameters	6-135
<b>Vertical spline method</b>	<b>6-137</b>
Introduction	6-137
Spline alignment	6-137
Locate point	6-138
Respecify point	6-139
Delete point	6-140
Display parameters	6-140
<b>Selection methods (Alignment)</b>	<b>6-141</b>
ALIGNMENT point selection methods (PSMs)	6-142
ALIGNMENT data amendment methods	6-146
<b>Railways</b>	<b>6-149</b>
Introduction	6-149
Component library	6-152
Dutch clothoid length calculation	6-155
Dutch transition calculation	6-156
Report slope length	6-158

Special geometry	6-159
Component definition	6-159
Suitable components	6-161
Turnout configuration (curved)	6-162
Turnout configuration (straight)	6-164
Crossing configuration	6-165
Symmetric configuration	6-166
Turnout details (type 1)	6-167
Crossing details	6-169
Symmetric details	6-170
Turnout details (type 2)	6-171
Component review	6-172
<b>Associate alignments</b>	<b>6-173</b>
<b>Non-interactive alignment</b>	<b>7-1</b>
<b>Major option HCUSP</b>	<b>7-1</b>
Description and brief theory	7-2
Data preparation	7-6
<b>Major option HALGN</b>	<b>7-12</b>
Main features	7-12
Transitions	7-18
Data preparation	7-29
Minor option 300 Initial data record	7-30
Minor option 301 Element data	7-31
Minor option 302 Offset alignment	7-34
Minor option 303 Special chainages	7-35
Minor option 304 Special chainage intervals	7-35
Minor option 305 Continuation record	7-36
Output	7-36
<b>Major option VCUSP</b>	<b>7-46</b>
Theory	7-47
Data preparation	7-49
<b>Major option VERAT</b>	<b>7-52</b>
Data preparation	7-55
<b>Major option VALGN</b>	<b>7-59</b>
Data preparation	7-64

<b>Geometric design</b>	<b>8-1</b>
Principles of geometric manipulation	8-3
<b>Major option DESIGN</b>	<b>8-20</b>
Access to major option DESIGN	8-20
Minor option 100 Add string: constant H / constant C	8-23
Minor option 101 Add string: linear H / constant C	8-25
Minor option 102 Add string: reverse H / constant C	8-26
Minor option 103 Add string: extend/contract crossfall	8-27
Minor option 104 Horizontal extension of slope/offset	8-30
Minor option 105 Intersection of 2 slopes	8-31
Minor option 106 Hard shoulder design	8-36
Minor options 107/108 Automatic subgrade design	8-41
Minor option 107/108 Subgrade design	8-42
Minor option 110 Add string: constant H / constant V	8-45
Minor option 111 Add string: linear H/constant V	8-47
Minor option 112 Add string: reverse H/constant V	8-48
Minor option 120 Amend levels: constant vertical offset	8-49
Minor option 121 Amend levels: linear vertical offset	8-50
Minor option 122 Amend levels: symmetrical reverse curve offset	8-51
Minor option 123 Amend levels: spline curve offset	8-52
Minor option 125 Amend levels: reverse circular curve offset	8-54
Minor option 126 Amend levels: biquadratic reverse curve offset	8-56
Minor option 130 Amend levels: constant crossfall	8-57
Minor option 131 Amend levels: linear crossfall	8-57
Minor option 132 Amend levels: symmetrical reverse curve crossfall	8-58
Minor option 133 Amend levels: superelevation	8-60
Minor option 134 Amend levels: extend crossfall (2 strings)	8-62
Minor option 135 Amend levels: reverse circular curve crossfall	8-65
Minor option 136 Amend levels: biquadratic reverse curve crossfall	8-66
Minor option 099 Invoke the simplified design process	8-67
Minor option 140 Add M-string	8-68
Minor option 141 Create curve	8-69
Minor option 142 Create straight	8-71
Minor option 145 Create circular	8-74
Minor option 146/147 Create three centre curve	8-78
Minor option 152 Tilted plane	8-81
Minor option 160 Report displacements	8-83
<b>Interface analysis</b>	<b>8-86</b>
<b>Major option INTERFACE</b>	<b>8-112</b>
Major option INTERFACE - Graphics	8-112
Height criteria	8-113
Define strings	8-115



Input macro data	8-116
Simple single slope	8-117
Simple slope/berm	8-118
Rounded/standard slope	8-119
Add discontinuities	8-124
Major option INTERFACE - Linemode	8-124
Minor option 259 Height criteria	8-125
Minor option 260 Define strings	8-126
Minor option 261, 262 Interface details	8-128
Minor option 263 Invoke interface analysis	8-135
Minor option 264 Invoke rounding	8-135
Output from major option INTERFACE	8-136
Worked examples	8-138
Design standards for rounded/standard slopes	8-175
<b>Extraction of sections through models</b>	<b>9-1</b>
<b>Major option SECTION</b>	<b>9-10</b>
Access to major option SECTION	9-11
Minor option 170 Long - between 2 points	9-14
Minor option 171 Long - along a string	9-15
Minor option 173 Cross - relative to a string	9-21
Minor option 174 Cross - relative to a master	9-23
Minor option 175/176 Visibility along/against a section	9-25
Minor option 177 Long - through triangulation	9-29
Minor option 178 Cross - through triangulation	9-30
Section drawing details	9-31
<b>Calculation of volumes</b>	<b>9-35</b>
Method of computation	9-35
<b>Major option VOLUME</b>	<b>9-45</b>
Access to major option VOLUME	9-46
Model for VOLUME	9-47
Minor option 050 Volume using parallel sections	9-49
Minor option 051 Volume environment	9-51
Minor option 052 Volume using cross sections	9-55
Minor option 053 Auto standard profile	9-56
Minor option 054 Standard profile and existing sections	9-58
Minor option 055 Define standard profile	9-60
Minor option 056 Two existing cross sections	9-62
Minor option 058 Models for VOLUME	9-65
<b>Mass haul analysis</b>	<b>9-67</b>

Application of major option VOLUME to Mass Haul	9-68
Mass haul analysis	9-69
<b>Major option HAUL</b>	<b>9-71</b>
Minor option 070 Define a scheme volume string	9-72
<b>Minor option 071 Include volumes in scheme volume string</b>	<b>9-72</b>
Minor option 072 Mass haul analysis	9-73
Minor option 073 Bulking/shrinkage factors	9-74
Minor option 074 Mass haul adjustment (Import and Export)	9-75
Minor option 074 Import adjustment	9-75
Minor option 074 Export adjustment	9-76
Minor option 075 Carry out mass haul analysis	9-76
 <b>HAUL macros</b>	 <b>9-77</b>
Macro MASSDRAW	9-77
 <b>Analysis by triangulation</b>	 <b>10-1</b>
Introduction	10-1
Principles of surface triangulation	10-2
 <b>Major option TRIANGLE</b>	 <b>10-11</b>
Access to major option TRIANGLE	10-11
Minor option 960 Triangulate a string model	10-14
Minor option 961 Trim triangulation	10-16
Minor option 962 Full ISOS from 2 models	10-19
Minor option 963 Subdivide triangulation	10-21
Minor option 964 ISOS from stored triangles	10-23
Minor option 965 Simple ISOS from 2 models	10-24
Minor option 966 Grouping of triangles	10-25
Minor option 967 Group triangles by criteria	10-34
 <b>Section 177/178</b>	 <b>10-37</b>
Minor option 177 Long - through triangulation	10-37
Minor option 178 Cross - through triangulation	10-38
 <b>Major option SURFACE</b>	 <b>10-40</b>
Access to major option SURFACE	10-40
Minor option 970 Generate contours	10-43
Minor option 971 Generate isopachytes	10-46
Minor option 972 Generate ridges/valleys/flow lines	10-49
Minor option 973 Generate flow lines	10-51
Line colour selection	10-52

<b>Major option PRISM</b>	<b>10-54</b>
Access to major option PRISM	10-54
Minor option 910 Volume from triangulation	10-55
Minor option 911 Volume from isopachyte	10-58
Minor option 912 Mean thickness of ISOS triangulation	10-59
<b>Visualisation</b>	<b>11-1</b>
Introduction to perspective views	11-1
<b>Major option VIEW</b>	<b>11-14</b>
Major option VIEW - Graphics	11-14
Access to major option VIEW	11-14
Define system parameters	11-15
Define VIEW parameters	11-16
Eye and target points	11-17
Photomontage	11-17
Create view	11-18
Major option VIEW - Linemode	11-19
Minor option 920 Definition of viewing parameters	11-20
Minor option 921 Definition of picture orientation	11-20
Minor option 922 Definition of photomontage points	11-22
Minor option 923 Production of perspective view	11-23
Minor option 924 Sketch facility	11-23
<b>Major option VISUALISE</b>	<b>11-32</b>
Introduction to the MOSS Visualisation System	11-32
Description of operation	11-33
Major option VISUALISE	11-34
Access to major option VISUALISE	11-36
VISUALISE options	11-38
Group triangles	11-38
Make assignments	11-46
Review assignments	11-53
Define eye and target	11-59
Clear visualisation	11-59
EPIC Data Store report	11-60
Submit EPIC data	11-61
<b>Major option DRAINAGE</b>	<b>12-1</b>
Introduction	12-1
Outline of design process	12-3
Micro Drainage	12-5
WALLRUS	12-7
Assumptions and limitations	12-8

## CONTENTS

---

String storage in DRAINAGE	12-8
Macrosymbols used in DRAINAGE	12-10
Drawing a network	12-10
Terms and definitions	12-11
Parameters and defaults	12-11
MOSS Drainage File (MDF)	12-13
Access to major option DRAINAGE	12-19
Drainage design	12-20
Add individual manholes	12-21
Add offset manholes	12-23
Amend manhole	12-27
Delete manhole	12-28
Manhole proximity check	12-28
Amend position levels	12-30
Add branch	12-30
Check branches	12-34
Respecify manhole position	12-34
Check pipe lengths	12-35
Insert manhole	12-36
Remove manhole	12-38
Resequence	12-40
Move manhole	12-40
Amend pipe details	12-42
Delete branch	12-44
Create 3D string	12-44
Add gully	12-45
Amend gully	12-48
Delete gully	12-48
Manhole defaults	12-49
Pipe defaults	12-50
Gully defaults	12-51
Proximity check defaults	12-52
Area calculations	12-53
Impervious area	12-61
Roof area	12-62
Drainage analysis - Micro Drainage	12-63
Drainage analysis - Wallrus	12-65
Drainage analysis - MicroRAT	12-72
MOSS Drainage Format	12-76
Drawing management	12-80
Report manholes	12-81
Report branches	12-84
Report gullies	12-86
Copy drainage model	12-87
<b>DRAINAGE macros</b>	<b>12-88</b>

Macro LONGDRAI	12-88
Macro PLANDRAI	12-90
<b>Customising Moss</b>	<b>13-1</b>
Major option MACRO	13-1
Introduction	13-1
Command macros	13-2
Minor option 900 Use a macro	13-6
Minor option 901 Add macro to library	13-7
Minor option 902 Delete macro from library	13-11
Minor option 903 Report macro	13-12
Macrosymbols and macrolines for drawing	13-13
Minor option 906 Add macrosymbol/macroline to library	13-14
Minor option 907 Delete macrosymbol/macroline from library	13-19
Minor option 908 Report macrosymbols/macrolines	13-19
<b>Major option MACROSYMBOL</b>	<b>13-21</b>
Access to MACROSYMBOLS	13-21
Macro selection	13-22
Macro details	13-23
Macro options	13-24
Selection method menu	13-26
Point selection methods (PSMs)	13-26
Dynamic menu	13-27
Macro elements or macrosymbols	13-28
Status indicators	13-30
Line definition	13-30
<b>Major option UPM</b>	<b>13-32</b>
Description	13-32
Method of use	13-32
Invoking a UPM	13-32
<b>External Interfaces</b>	<b>14-1</b>
Major option GENIO	14-1
Access to major option GENIO	14-2
Minor option 080 General input of strings	14-11
Minor option 081 General output of strings	14-16
Minor option 082 Input of section information	14-19
Minor option 083 Output of section information	14-22
Minor option 085 Partial output of triangulation	14-24
Minor option 087 Section information for HECB drainage design	14-26
Minor option 089 Full output of triangulation	14-28
Minor option 090 Full input of triangulation	14-30

<b>Major option 3DDXF</b>	<b>14-32</b>
Minor option 451   Transfer strings to DXF	14-32
Minor option 453   Transfer triangulation to DXF	14-33
<b>External programs</b>	<b>14-56</b>
Introduction	14-56
Site Measurement Module	14-60
Program MSOSPP	14-63
Macro ORSDRAW	14-82
Program MSMODCNV	14-85
Program MSDPFCNV	14-87
MICRORAT and WALLRUS	14-89
MSPLOTTER	14-89
MSDISPLAY	14-90
Program MSMIFILE	14-90
Program MS2DDXF	14-92
Program MSDXFMOSS	14-98
Program MSMINT	14-107
Program MSDAMS	14-113
Program MSSHOW	14-120
Program MSDOCUMENT	14-122
Program MSCRMENU	14-122
<b>MIFILE</b>	<b>14-1</b>
Introduction	14-1
Summary of Intermediate File	14-5
Global Information Entries	14-6
Group Entries	14-18
Drawing Entities	14-22
<b>Errors and warnings</b>	<b>A-1</b>
MOSS error messages	A-2
MOSS warning messages	A-85
MOSS system error messages	A-122
<b>Software fonts</b>	<b>A-124</b>
<b>User Support Service</b>	<b>A-126</b>
User report form	A-126
Program MSSUPPORT	A-127
New Development Enhancement Requests	A-129
<b>SiteMOSS</b>	<b>A-135</b>

## CONTENTS

---

Introduction	A-135
Major options	A-135
Standalone programs	A-137
<b>VisMOSS</b>	<b>A-138</b>
Introduction	A-138
Major options	A-138
Standalone programs	A-140
<b>Sys3MOSS</b>	<b>A-141</b>
Introduction	A-141
Major options	A-141
Standalone programs	A-143
<b>FranMOSS</b>	<b>A-144</b>
Introduction	A-144
Major options	A-144
Standalone programs	A-146
<b>MiniMOSS</b>	<b>A-147</b>
Introduction	A-147
Major options	A-147
Standalone programs	A-149
<b>CzechMOSS</b>	<b>A-150</b>
Introduction	A-150
Major options	A-150
Standalone programs	A-152

# Chapter 1 Introduction

## Introduction

This manual is for regular users of MOSS. It explains all the facilities available in MOSS, and provides the data you need to use them in various applications.

### Structure

MOSS is described in terms of its major options (in MOSS, facilities accessed by commands are called 'options'). The chapters feature the engineering options in the broad sequence that you would use them in an engineering design:

- for creating a model of the existing surface and perhaps sub-surfaces
- for developing surface models of new works, and for analysing and comparing these with the model of the existing surface
- for producing contract information, including drawings.

This approach works well because most of the options perform a specific engineering task.

However there are some options that perform general or house-keeping tasks and these are documented in Chapter 2: 'Throughout MOSS', ahead of the chapters for the engineering options.

The overall sequence of the manual is:

### Part 1: Introduction

- Chapter 1: Introduction
  - Introduction
  - Help on HELP
- Chapter 2: Throughout MOSS.
  - Graphics
  - Linemode
  - Models and the DPF
  - General information
  - General options
  - Global minor options
- Chapter 3: Drawing options
  - Major option NEWDPF
  - Major option NEWRPF
  - Major option DRAW
  - Major option ENHANCE



- Major option CLIP
- Major option LAYOUT
- Chapter 4: General options
  - Major option EDIT
  - Major option REPORT
  - Major option COPY
  - Major option AREA

## **Part 2: Engineering Facilities**

Chapters 5 –14 cover the engineering options in the order that you would use them in a typical engineering design, in the sequence:

- Chapter 5: Survey options
  - Major option IDIGIT
  - Major option SURVEY
  - Major option SETOUT
- Chapter 6: Interactive alignment
  - Major option ALIGNMENT
  - Horizontal element
    - Horizontal IP
    - Horizontal spline
  - Vertical element
    - Vertical IP
    - Vertical spline
  - Selection methods
  - Railway
  - Associate alignments
- Chapter 7: Non Interactive alignment
  - Major option HALGN
  - Major option HCUSP
  - Major option VERAT
  - Major option VALGN
  - Major option VCUSP
- Chapter 8: Geometric design
  - Major option DESIGN
  - Major option INTERFACE
- Chapter 9: Analysis by section
  - Major option SECTION
  - Major option VOLUME
- Chapter 10: Analysis by triangulation
  - Major option TRIANGLE
  - Major option SECTION (177/178)

Major option SURFACE  
Major option PRISM  
**MAJOR OPTION CONTOUR**

Chapter 11: Visualisation  
Major option VIEW  
Major option VISUALISE

Chapter 12: Drainage  
Major option DRAINAGE

Chapter 13: Customising MOSS  
Major option MACRO  
Major option UPM

Chapter 14: External interfaces  
GENIO  
3DDXF  
MSSMTRANS  
MSOSPP  
WALLRUS  
MICRORAT  
MSPLOTTER  
MSMIFILE  
MS2DDXF  
MSDXFMOSS  
MSMINT  
MSDAMS  
MSSHOW  
MSDOCUMENT  
MSCRMENU

### **Part 3: The Appendices**

Appendix 1: Errors & Warnings  
Appendix 2: Software Fonts  
Appendix 3: User Support  
Appendix 4: SiteMOSS  
Appendix 5: VisMOSS  
Appendix 6: Sys3MOSS  
Appendix 7: FranMOSS  
Appendix 8: MiniMOSS

## Format and conventions

The main features of the new formats and conventions are as follows:

- Minor options have standardised names (short versions of their descriptions)
- There is a fixed sequence of information for each minor option:

Description

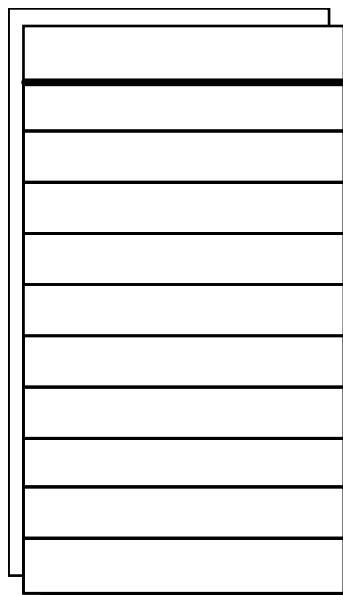
Input

Graphics

Linemode

Output

- Any of the sub-sections above may be accompanied by Notes, marked by a  $\diamond$  symbol and printed in italics to set them apart. Notes generally feature information whose nature is cautionary, exceptional, or specific to particular circumstances. The idea is that Notes qualify or modify the information in the main description of the option.
- Italics are also used to denote other specific types of information, as follows:
  - titles of other manuals or documents
- Bold type is also used in specific situations, as follows:
  - to denote hierarchy in margin sub-headings
  - for first use of important terms
  - for titles of figures.
- The following menu presentation indicates that you will need to scroll down the scrolling menu area to achieve the display shown.
- Mandatory fields in Linemode are prefixed by an asterisk (\*).



**Figure 1 - 1 Scrolling menu diagram**

## The MOSS documentation set

This manual is the main reference document for the MOSS program, and is the most comprehensive document in the whole documentation set.

The other documents of the set are:

- *Introduction to MOSS*

This booklet is for newcomers to MOSS. It describes the basic concepts and principles behind MOSS, explains what you can achieve with it, and outlines how to use it. It is intended to be read before using MOSS at a workstation, perhaps in the week before attending the MOSS training course.

It could also be useful to senior engineers who need to understand what MOSS can do and basically how it works, though do not use MOSS themselves.

- *Getting Started with MOSS*

This book helps new users to use MOSS at a computer workstation or terminal. It describes the various ways to access MOSS, and follows with step-by-step tutorial scripts showing how to create surface models, and how to display and manipulate them.

- *Quick Reference Guide to Linemode*

This is for those who are familiar with the concepts and principles of MOSS, know how to use it, but can't remember the input data required for a particular Linemode facility. It simply lists the type and sequence of input data for each option.

- *Installing MOSS*

There is one Installation Guide for each workstation on which MOSS is supported. Each guide describes how to install MOSS and how to perform simple tests to confirm that the installation has been successful.

- *MOSS Systems Manager's Reference*

There is one System Manager's Reference for each workstation on which MOSS is supported. Each guide describes how MOSS is configured and how to administer and maintain the system.

- *MOSS Guide to UPM*

This book is for the experienced MOSS user and describes how to develop and distribute User Programmable Modules (UPMs). The book details the programming commands available in major option UPM as well as aspects of UPM security and licensing.

- *Guide to MOSS Software fonts*

This book is for System Administrators and describes how to create and implement your own software font within MOSS. Users do not need to refer to it, as the methods used to invoke software fonts in MOSS drawings are described in MOSS User Manual.

- *Release Notes*

This document introduces the latest features and facilities available to users of the MOSS System, and details all the changes made since the last major release.

# Help on HELP

## Introduction

Major option HELP provides in-context access to the MOSS document collection and is accessed by selecting 'Help' from the static menu area. It is a quick and easy method of opening the documentation at the page appropriate to the subject you specify.

Major option DOCUMENT provides access to the full MOSS document set from the Housekeeping menu or from Linemode by typing *document*. The information accessed by both major options is identical.

The purpose of Help on HELP is to assist you in navigating successfully through the MOSS documents within the MOSS document collection. Successful navigation is fundamental in accessing appropriate information.

Navigation in paper books is something we all take for granted and have learned by experience; we automatically use help by searching the index and table of contents when other methods do not succeed. The problem with electronic books is the lack of tactile guides such as bulk, division markers and so on.

WorldView<sup>E</sup>, which drives major option DOCUMENT, will run simultaneously with other applications on a wide variety of workstations and PCs, enabling you to access information without interrupting your workflow. You can print individual document files or groups of files (called WorldView collections). In addition, features such as search collection, indexes, tables of contents and bookmarks allow you to find information quickly.

Navigation in electronic books requires some understanding of the information structure - the way in which documents, books, collections and libraries are used in the navigation hierarchy.

The purpose of Help on HELP is to assist you in navigating successfully through the MOSS documents within the MOSS document collection.

## Terminology

**Library** - this is the top level in the structure. One or more sub-libraries are used to categorise a selection. For example; MOSS library, PaveMOSS library. A full description of the library structure is shown in Figure 1 - 2 below. The library is accessed by a hot zone iconbutton where applicable.

**Collection** - this relates to a book. The term 'book' is not used, as electronically there is no need to sub-divide books into volumes, sections, chapters and so on. The MOSS User Manual and Quick Reference Guide are individual document collections.

**Meta-collection** - A meta-collection is a combination of two or more existing collections and isare used specifically for search purposes. For example, you can combine the MOSS and PaveMOSS collections permitting search functions across both. Meta-collections are created in the


File New Meta-Collection menu. See WorldView Help for further instructions on how to use meta-collections.

**Document** - this term is used to define a number of pages of information contained in a single file. Theoretically there is no limit to the size of an electronic document. Within a MOSS document collection, such as the User Manual, each document relates to a single subject or MOSS major option. This aids choice when reviewing the results of a full-text query as the major option or area of the document collection is identified.

**Table of contents** - a navigation aid. In electronic document collections, more than one table of contents may exist. For example, tables of contents may be provided to give an overview and, at subsequent and lower levels, tables of contents may be more detailed with greater focus.

Tables of contents do not include page numbers, but have hypertext links which, when activated by a click of the mouse button, take you to the selected subject.

**Index** - a navigation aid. Indexes do not include page numbers, but instead have hypertext links which, when activated by a click of the mouse button, take you to the selected subject.

**Hyperlink**  - a navigation tool. When activated by a single click on the icon with the left hand mouse button, the information to which it is linked is accessed. The target of the hypertext link will be highlighted using video inversion when it is displayed.

◇ *The hyperlink symbol is shown as  on PC hardware.*

## The MOSS library

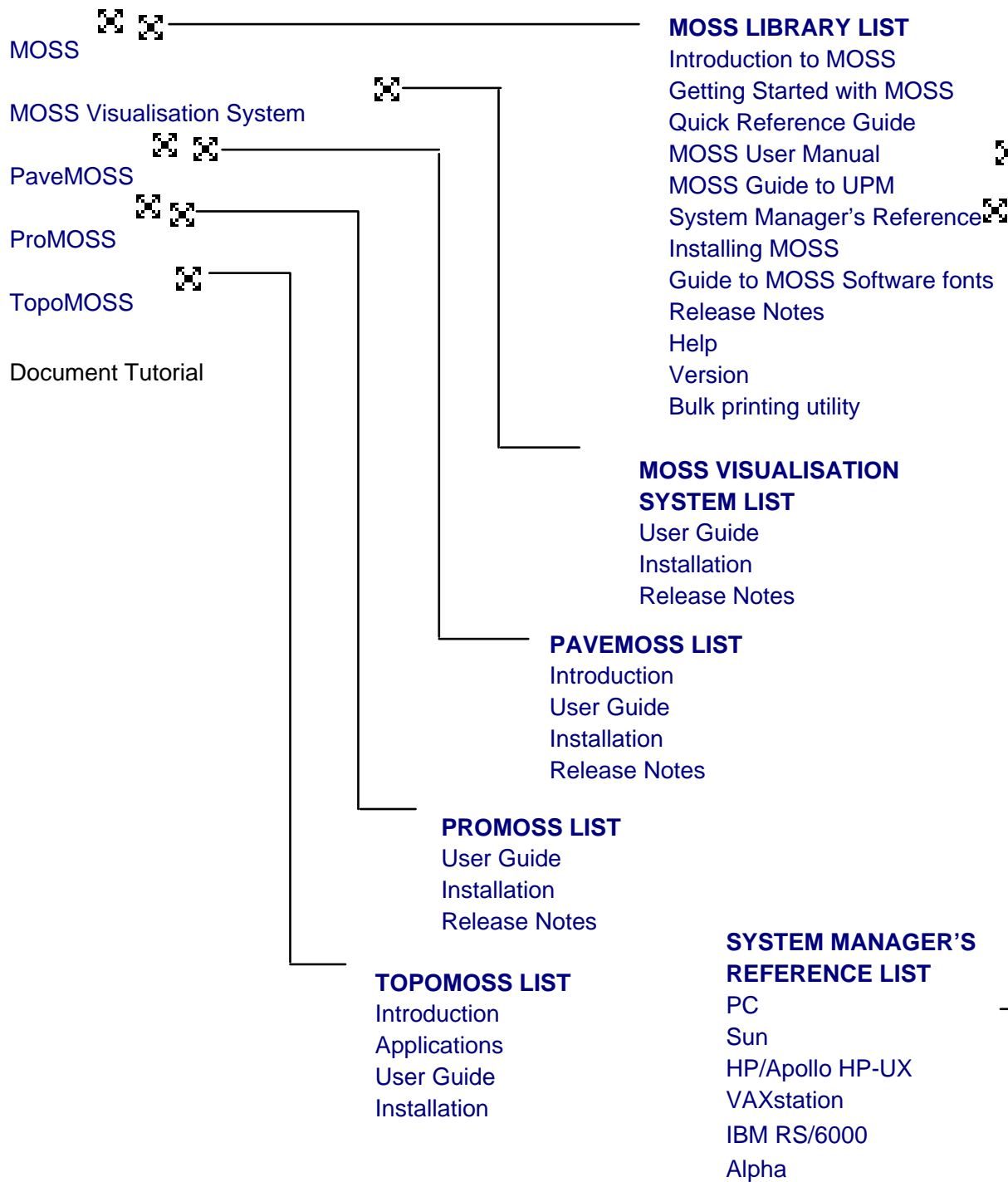
The MOSS library is a list of collections or groups of collections. These collections are grouped to reflect MOSS products, or the needs of individuals such as System Administrators.

### Library structure

The MOSS library is continually being expanded to ensure that all information about new products and changes to current products is available to you. Different areas of the library will have been created at different times, and will therefore have different version numbers. Generally, the version number is given on each library list, and within each document on each page. Installation ensures that software and documentation are kept in step, however, you should check and confirm that they are compatible if you have any doubts

Different areas of the library will have been created at different times, and will therefore have different version numbers. Generally, the version number is given on each library list, and within each document on each page. Installation ensures that software and documentation are kept in step, however, you should check and confirm that they are compatible if you have any doubts.

**LIBRARY LIST**



**Figure 1 - 2 MOSS Library structure**

A knowledge of the library structure is only valuable if you can pre-determine the location of information you require. If you are unable to locate information easily, use the most appropriate Search facility. The Collection Structure Browser uses a graphical interface to show a collection's hierarchical structure. It displays the titles of document containers and the



titles of documents within those containers and from the Browser you can cause any element of a collection to be displayed in WorldView. This facility may assist you further in locating the required information.

## WorldView Functionalities

### Menus and Commands

WorldView commands are available on pulldown menus accessible from the menu bar in the WorldView window. Commands can also be made into icons on an icon bar for quicker access.

### Customising WorldView Features

You can customise WorldView by setting parameters either directly in the *Iview* file in your home directory (if you or your system administrator has copied it there) or in the Preferences dialog, which changes the parameters either temporarily or permanently, as you choose.

Because of the way in which WorldView is started by MOSS, you cannot set parameters on the WorldView startup command line.

### Accessing and Viewing Documents

WorldView displays documents up to 36 x 36 inches. The visible portion of the document depends on the size and resolution of your display.

There are various ways to access documents for viewing. You can access a single document or a collection of documents. Accessing a collection will give you access to a Titles list. When you have accessed a document collection, you can execute full-text queries to call up lists of documents that contain specific information. Once you have opened documents, you can follow hypertext links or bookmarks to other documents.

### Hypertext Links

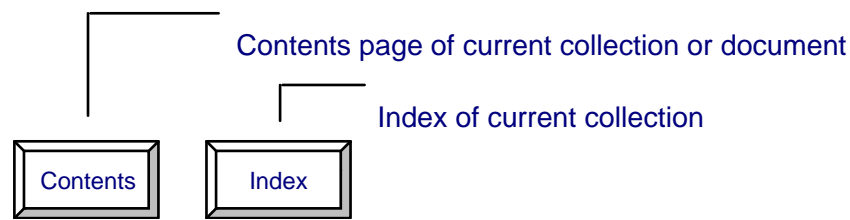
Hypertext links allow you to select and open a connected document automatically.

### Navigation between documents

Navigation throughout the collections provided by MOSS is achieved by selecting button icons.

In the top left corner of each page of a MOSS document are two icons (except in small documents where contents and index are inappropriate). These aid your navigation out of the document and back to the library and are shown below.

The library icon on the contents page of each collection returns you through the current collection library to the MOSS library.



**Figure 1 - 3 MOSS collection button icons**

### Navigation within documents

To move around a document you can:

- use the keys marked PGUP and PGDN on your keyboard
- use the vertical scroll bar on the right hand side of the document window to scroll up and down and the horizontal scroll bars at the bottom of the window to scroll across the page
- use the mouse to select the previous page, next page, first page and last page and go to a selected page.

You can zoom in and out of the document by using the zoom commands under the View pulldown menu and you can also size the WorldView window by clicking on a corner of the window frame and dragging it out or in.


### Window Options

You have the option of opening each document accessed in WorldView in a new window or of reusing the current window. You can also choose to resize the document window to fit the document size or to keep the window size fixed. Finally, you can duplicate any window and the document within it.

## Help functionality

The functionality available in both HELP and DOCUMENT are well documented by the Interleaf WorldView product used for viewing the MOSS documents. The following is an overview of the features available to you:

### Menus and Commands

WorldView commands are available on pulldown menus accessible from the menu bar in the WorldView window. Commands can also be made into icons on an icon bar for quicker access. See Customising WorldView features 

### Printing

If your workstation is connected to a supported printer, you can print the document you are viewing by executing commands from the Print dialog box accessible from the File pulldown menu in the WorldView window. You have the option to print the current page, a range of pages, or the entire document.

*◇ Some large documents within the MOSS collection are composed of a number of smaller documents. This is not apparent when viewing the collection, but when you select Print All you may not be able to print the entire document in one go and will have to select each sub-document in turn.*

### Simplifying print

An easier way of printing entire documents is to use the **Bulk Printing utility** which is accessed from the MOSS library. This feature allows you to print one or more documents in coherent sections of the User Manual, Quick Reference Guide or UPM. Each main publication has been divided into logical sections and the total number of pages and print file size of each section is shown.

## WorldView Help

WorldView Help is available through the Help pulldown menu in the WorldView menu bar. Follow the hypertext links beside the items on the Help Contents menu to find instructions for using WorldView features. You can also search for key words in the Help collection.

### Accessing and Viewing Documents

WorldView displays documents up to 36 x 36 inches. The visible portion of the document depends on the size and resolution of your monitor.

There are various ways to access documents for viewing. You can access a single document or a collection of documents. Accessing a collection will

give you access to a Titles list. When you have accessed a document collection, you can execute full-text queries to call up lists of documents that contain specific information. Once you have opened documents, you can follow hypertext links or bookmarks to other documents.

When selected, Help opens a new WorldView window so that you can find the information you require, and when you have found it, revert to the previous window.

The Help window can be positioned anywhere on the screen to enable the DOCUMENT window to be viewed. This is done by pressing and holding the left hand mouse button whilst the cursor is positioned on the window frame and moving the silhouette to the new position. When it is in the required position, release the mouse button.

The Help pulldown has the following selections:

- **Contents** - opens a table of contents for the help
- **Index** - opens the index for help
- **Search in Help** - searches for words or phrases in the Help collection
- **About WorldView** - displays a copyright notice

To close the Help window, select the File pulldown menu and Close (Exit will close down WorldView).

## Navigating

The page control panel located on the icon bar allows you to click on buttons to go to the next page, the previous page, the first page, and the last page, as well as to specify a particular page.

You can also navigate through documents using the scroll bars belonging to each WorldView window. You can scroll to a new page or view different parts of the same page (when the page is larger than your screen).

## Window Options

You have the option of opening each document accessed in WorldView in a new window or of reusing the current window. You can also choose to resize the document window to fit the document size or to keep the window size fixed. Finally, you can duplicate any window and the document within it.

## Zooming

You can zoom a document to 50-200 percent of its original size. Zooming larger is useful when you want to examine an illustration very closely or when you want to enlarge the display of a small font. Zooming smaller is useful when you want to see more than one page at a time on the same screen. The Zoom Box allows you to zoom a specific area of a document page.

## Printing

If your workstation is connected to a supported printer, you can print the document you are viewing by executing commands from the Print dialog box accessible from the File pulldown menu in the WorldView window. You

have the option to print the current page, a range of pages, or the entire document.

◇ ~~Some large documents within the MOSS collection are composed of a number of smaller documents. This is not apparent when viewing the collection, but when you select Print All you may not be able to print the entire document in one go and will have to select each sub-document in turn.~~

## Simplifying print

An easier way of printing entire documents is to use the **Bulk Printing utility** which is accessed from the MOSS library. This feature allows you to print one or more documents in coherent sections of the User Manual, Quick Reference Guide or UPM. Each main publication has been divided into logical sections and the total number of pages and print file size of each section is shown.

## Searching

There are two ways to search for a text string (a word, phrase or other series of characters)

- Text search - a search backward and forward in the document you are currently viewing, initiated from the Search Text pulldown menu
- Full-text search - a search across an entire collection of documents, initiated from the Search Collection pulldown menu

There are three different types of full-text search: Standard for a single text string or expression; Advanced for a query composed of two or more text strings combined with search operators; Intuitive to find all documents within a collection containing information related to a large block of text.

You can also search across a number of existing collections by combining them into a meta-collection, created under the File pulldown menu. However, before you can perform the search the .cfg (configuration) file defining the meta-collection must be saved in a directory for which you have write permission.

Also available under the Search pulldown menu are options to search for hypertext links and notes.

## Notes

By using WorldView notes you can record comments about the documents you are viewing, save the comments electronically, retrieve them, and make them accessible to other users. These may be observations, example input files or a record of a problem reported to the hotline. You must have write access to the notes file in order to create notes.

Notes files are ASCII files that contain the text of notes (and note icon positioning information). They can be printed out at the system level to provide hardcopy. They can also be moved to almost every text editor or word processor, however all text format information will be lost.

Notes may be written to a specific directory, which you can set up using Edit Preferences dialog. You can keep notes personal to yourself or make them public to your network and fellow users.

WorldView also provides auto–display capability for notes, which opens them automatically, whenever a viewer scrolls to the pages on which they reside.

### **Bookmark List**

The Bookmark list provides a listing of each document marked during the current viewing session. You can leave a document and return to a previously marked document by choosing it from the Bookmark list. The Bookmarks list is useful when tracking information about a particular topic because you can mark each place that refers to a topic and return to it via the list.

By setting a parameter, you can also save Bookmark lists between WorldView sessions. Doing so gives you immediate access to documents visited in a previous session.

Another method of moving between pages in documents is to use the View Back command. This returns you to previously visited pages in sequence.

### **Hypertext Links**

Hypertext links allow you to select and open a connected document automatically. WorldView provides a default image for hypertext link markers and you can also designate your own bitmap file to substitute another image.

### **Customising WorldView Features**

You can customise WorldView by setting parameters either directly in the *Iview* file in your home directory (if you or your system administrator has copied it there) or in the Preferences dialog, which changes the parameters either temporarily or permanently, as you choose.

Because of the way in which WorldView is started by MOSS, you cannot set parameters on the WorldView startup command line.

Further information on all functionality is available within WorldView Help.

# Chapter 2 Throughout Moss

## Throughout MOSS

This chapter describes the facilities which are available throughout MOSS and introduces some general principles. Some of the material is also in *Introduction to MOSS*.

There are three main sections:

### **MOSS's modes**

Graphics mode  
Linemode  
UPM  
Background mode

### **Models and the Draw Picture File**

Objects and elements  
Strings and string labelling  
Subreferences

### **General information**

Keyboard entry  
Curve fitting  
Discontinuities  
Negative coordinates  
Graphics selection methods  
The parameter file  
Error handling

## MOSS's modes

You communicate with MOSS through a set of commands which control the input, manipulation, analysis and output of sets of data. The data represents strings, points, and ultimately models.

The commands have a two tier structure, of **major** and **minor options**, in which the majority of major options have a set of minor options nested within them. The names of the major options reflect their function; for example, EDIT, or COPY or REPORT. The minor options are always three digit numbers in the range 000-999.

You can operate MOSS in any one of three modes:

- Graphics mode
- Linemode

- Background mode

For the same data, each mode has its own method of input. You use the mode that suits your level of expertise in MOSS or the complexity of the data.

## Graphics

Graphics is the easiest and most effective mode to use. Text or graphics menus lead you through sets of major and minor options, and the graphics display enables a visual check on the soundness of your approach.

You communicate with MOSS using, first, a desktop 'mouse' to move the cursor on the screen to select menu boxes, and second, the keyboard to enter data into the boxes.

The results of your input are displayed instantaneously on the graphics screen. You need a graphics screen for this mode.

The great advantages of graphics are:

- easy input (selecting from menus with a mouse)
- versatile graphics display for, say, highlighting errors
- immediate graphics display, giving greater efficiency and productivity.

There's more about graphics in the next section.

The *Getting Started* manual contains an explanation of graphics mode and provides a number of tutorial scripts as an introduction for a new user.

## Linemode

In linemode you enter data one line at a time. It is the method to use when you are proficient in MOSS and the number of lines of input is relatively small.

Linemode is described in more detail later in this chapter.

## UPM

UPM may be used in both Linemode and IGmode.

In Linemode the UPMs may be designed to be interactive to obtain essential input information from the user prior to processing.

In IGmode UPMs may be designed to use the Scrolling Menu Area, in the same way as standard MOSS to obtain essential input information from the user prior to processing.

## Background mode

This mode is also known as Non-interactive mode. As in linemode, you have a prepared set of data ready for submission on a line by line basis.

However, once the file of data is submitted to MOSS you have no further control over the processing. You cannot watch the processing, as with the INPUT facility. The data is processed, and the output is written to an output file for later inspection.

Background mode is best for processing large data sets or where you expect a long processing time, as with contouring a large model.



Background mode will process a large data set while you carry on with other work.

## Initial entry to MOSS

To enter MOSS, type *moss* at the system prompt.

The system will ask you:

Do you wish to enter IGMODE, LINEMODE, UPM or Non-Interactive.

(Type I, L, U, N, or FINISH to exit)

Type the letter corresponding to the mode you require, for example:

*I* <Return>

In this case, the graphics display will be loaded.

- ◇ *if your response is I then MOSS goes immediately into IGMODE.*
- ◇ *if your response is L then MOSS goes immediately into LINEMODE.*
- ◇ *if your response is N then you will prompted for filenames etc. to run MOSS non-interactively.*
- ◇ *if your response is U then you will taken to UPM in IGMODE.*

Once you are in MOSS, you may switch between linemode and graphics mode.

From graphics mode, select the LINEMODE box in the dynamic area at the bottom of the screen.

From linemode, type the following:

*IG, <DPF>*

where <DPF> is the name of the Draw Picture File to be loaded. If this is left blank, the default DPF draw.dpf will be used.

If a Raster Picture File of the same name as the specified DPF exists, this will also be loaded.

# Graphics

Graphics is sometimes called IG mode or Interactive MOSS.

As computer technology and the MOSS system have evolved, the emphasis has moved from graphics as a secondary process to graphics as the main design mode. Many of the major and minor options of MOSS can now be accessed directly through the graphics menus. Even options that appear to have little influence on the drawings are included in the menus, so that you don't have to keep changing modes.

This section describes graphics mode, under the following sub-headings:

- Grouping of major options
- Overview
- The interactive graphics screen
- The static menu
- The scrolling menu
- The selection methods menu
- The dynamic menu

## Grouping of major options

### Graphics options

In graphics the major options are grouped as follows.

- Survey options
  - IDIGIT - Interactive digitiser
  - EDIT - Strings and points
  - COPY - Copy/move model data
  - REPORT - Models/strings/points
- Analysis options
  - AREA - Plan and slope
  - TRIANGLE - Triangulate/trim/group
  - SECTION - Extraction of strings
  - VOLUME - Section-based volume
  - SURFACE - Analyses and contours
  - PRISM - Prismatic volumes
  - EDIT - Strings and points
  - COPY - Copy/move model data
  - REPORT - Models/strings/points
- General options
  - CREATE - Empty model
  - DELETE - Remove entire model

RENAME	- Change model name
EDIT	- Strings and points
COPY	- Copy/move model data
REPORT	- Models/strings/points
• Design options	
ALIGNMENT	- H & V alignment design
SECTION	- Extraction of sections
DESIGN	- Feature strings
INTERFACE	- Earthworks design
DRAINAGE	- Networks and areas
EDIT	- Strings and points
COPY	- Copy/move model data
REPORT	- Models/strings/points
• Drawing options	
DRAW	- Working drawings
DRAW	- Contract drawings
ENHANCE	- Add annotation
CLIP	- Clip drawings
LAYOUT	- Drawing sheets
MACROSYMBOLS	- Create/amend/store
VIEW	- Perspective/Photo
VISUALISE	- Prepare EPIC data
NEWDPF	- Select different dpf
NEWDPF	- Select different rpf
2DDXF	- DPF conversion to DXF
REPORT	- Models/strings/points
• Housekeeping options	
COMPRESS	- Reduce model file size
SECURE	- Stop inadvertent use
FREE	- Remove security
RENAME	- Change model name
REPLAY	- Interactive replay
DOCUMENT	- On-line documentation
REPORT	- Models/strings/points

## Overview

### Using graphics

In graphics mode you use a desktop 'mouse' device to move a cursor on the screen to select major and minor options from a series of clear simple menus. Frequently used parts of the menus remain on the screen, supplemented by scrolling menus. As you invoke each major option its

associated minor options are displayed in menus. When you choose a specific minor option the scrolling menus present a series of fields where possible compatible with the standard input requirements of MOSS in linemode. The essential difference is that you can graphically select data from the screen, and that mandatory fields of data are automatically prompted and individually highlighted as data is required for input. You can enhance the menu structure of graphics mode still further by effective use of some of the global facilities, available in the static menu areas.

### Learning graphics

To help you appreciate the full functionality and flexibility of graphics mode, a number of tutorial scripts and demonstrations have been prepared. The examples have been pre-recorded and you can process them in a self-teach manner with varying levels of intervention, using major option REPLAY.

A typical learning exercise would be:

- Process a REPLAY example with no interruption to understand the contents being described.
- Process the same REPLAY example stopping each time a point needs to be explained. The point will be explained either by an associated script as in *Getting Started*, or through displayed text in REPLAY itself.
- Process the data yourself by keying/cursoring. By this stage you will have gained sufficient confidence to try different data.

### Ancillary facilities

It is not the intention of this section to describe the full range of graphics facilities. However it is important to appreciate that the graphics environment stretches beyond the interactive graphics menus. The following are examples of other facilities:

- IDIGIT
- LAYOUT
- DISPLAY, PLOTTER
- MIFILE, MIDXF
- ◇ *The options available within the graphics environment are not simply restricted to those with direct graphical results.*
- ◇ *You can use OUTPUT to store alphanumeric information as a permanent record for subsequent examination.*
- ◇ *Where graphical output is automatically generated, the style of presentation may be governed by default DRAW macros stored in the macrofile. You will only need to supply minimal data such as scales through the scrolling menus.*
- ◇ *For some options, only simple operations may be directly available. Nevertheless if you have a prepared data set of more complex options these are easily processed using INPUT.*

## The interactive graphics screen

### Introduction

The opening screen display in MOSS's graphics mode is shown in Figure 2 - 1.

There is a lot to take in, but overall there are just four main parts to it:

- the graphics area (the picture)
- the menu areas
- the message area
- the keyboard area.

Throughout this manual, 'display' as a noun means picture, text, and menus.

### Graphics area

This is the rectangular area occupying most of the screen and displaying the picture under consideration.

In graphics mode it always shows a graphical display. You can select the feature in the display you want your next action to apply to, by moving the screen cursor to the feature using a *mouse*, and clicking the mouse button.

### Menu area

The menu areas occupy the right hand side and part of the bottom area of the screen. They offer choices either for the way MOSS will behave until the next setting, or choices for your next action. You select your choice using the mouse/cursor as above.

There are four different menus:

- the static menu
- the scrolling menu
- the selection method menu
- the dynamic menu.

We'll return to the menus in more detail shortly.

### Message area

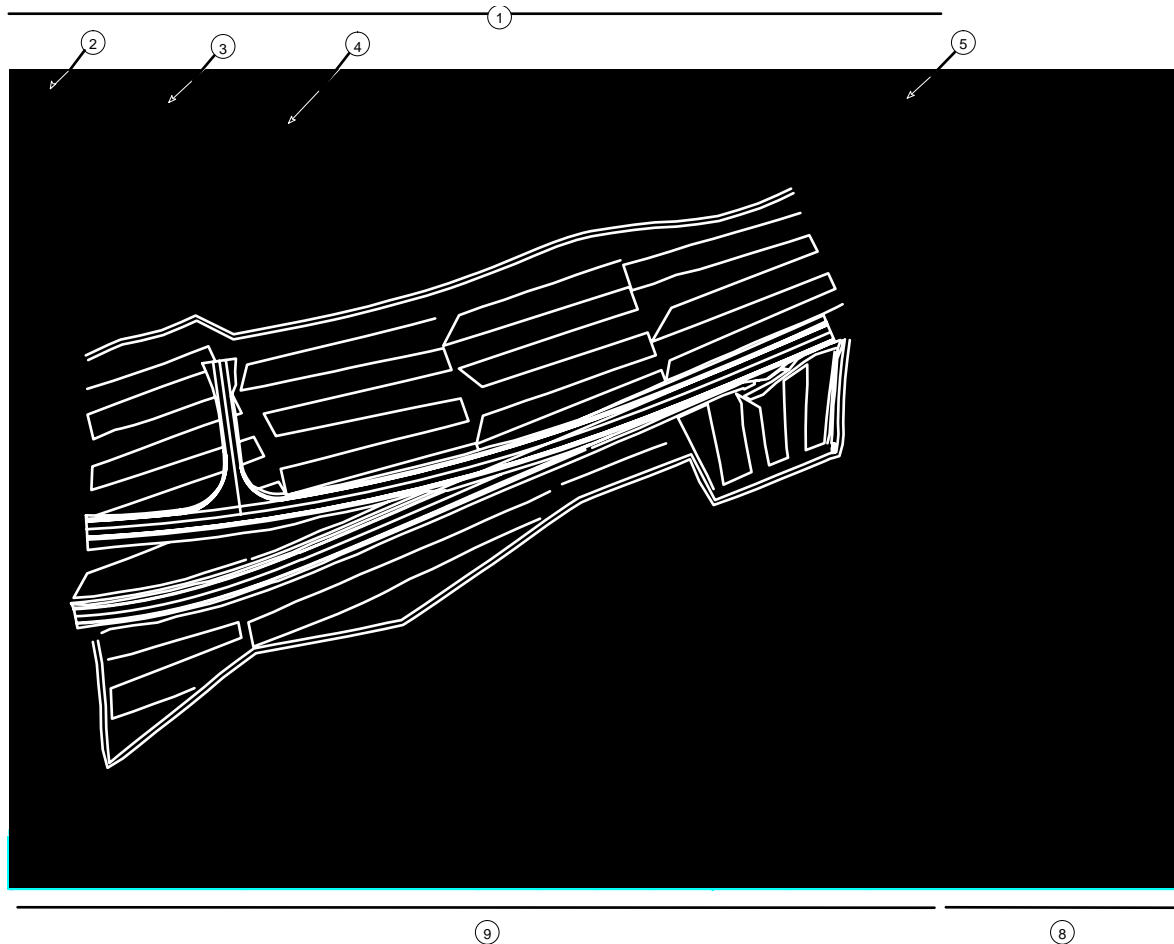
The message area displays messages of five types:

- prompts
- warnings
- error messages
- status messages
- reports of information such as point coordinates and radius.

## Keyboard area

The keyboard area displays alphanumeric text as you type it in at the keyboard.

In graphics mode you only need to type in data infrequently because most of the time you're using the mouse. Because of this, although the keyboard remains active, it's designed so that it cannot normally input to the graphics area. When you need to use the keyboard either the Keyboard box in the static menu is automatically highlighted, showing that the keyboard is connected to the graphics area or you select the Keyboard box yourself. As you type in the information, it is displayed in the keyboard area as confirmation. When you press [Return], if the information has the correct format and content, it is accepted, and the mouse is reconnected to the graphics area.



### Key:

1. Message areas
2. Status
3. Errors/Warnings
4. Prompts
5. Menu reference number
6. Static menu

7. Scrolling menu
8. Selection method menu
9. Dynamic menu

**Figure 2 - 1 The MOSS screen in graphics mode**

## The static menu

The static menu displays the functions that are available all the time in MOSS from any position within it; they are not option-specific.

These functions generally fall into four sub-groups:

- Style selection
- Display selection
- Window selection
- Proceed/Quit.

## Style selection

Apply	Colour	Style	Both
Line		Fill	
Text	Default	Curve	OFF

IMBOXES.DAT

**Figure 2 - 2 Style selection**

Style selection offers you choices of styles in which to display:

- lines (type and colour)
- text (type and colour)
- curve fitting (on or off).
- area hatching or fill (type and colour)

### Apply - style and colour

The Apply - colour, style defaults shown in Figure 2 - 2 are available whenever you are in graphics. You may use them to change, for example the default colour and style for lines, which will affect all subsequent lines; or apply the change to a specified element of the display. The Apply box allows the following operation methods to be used.

1. Selecting any of the four default boxes (–.–, Default, /////, Off) will prompt you to select both attributes

ie selecting the default line box will prompt for line colour followed by line style.

2. Selecting the APPLY box will generate a menu asking which defaults are to be applied -

when the defaults are selected

the APPLY menu will prompt for model, object, element to which the change of colour and style are to be applied.

3. Selecting any of the seven action boxes (Line, Text, Colour, Style, Fill Area, Curve, Both) will prompt you to select another action box to complete the selection.

For example if you select Line then the prompt will ask 'Colour', 'Style' or Both.

Similarly if you select Colour then the prompt will ask 'Line', 'Text' or 'Fill Area'.

- ◇ *For details of the equivalent options in Linemode, refer to Chapter 3, 'Major option DRAW'.*
- ◇ *In method 2 a second default may be changed by selecting another default box prior to applying the changed defaults.*

## Display selection

IMBOXES.DAT

MovCop	Erase	Envir	Help
Abandn	Visibl	Status	Sheet

**Figure 2 - 3 Display selection**

Display selection mainly offers you choices of what or how much to display (but also contains other items):

- MovCop* Manipulates elements, objects or text within the picture. In addition, individual strings or items of annotation may be associated with each other so that they may be manipulated as one object.
- Erase* Erases from the picture (not from the model file) the following: current sheet, models, objects, elements, windows, multiple elements.



<i>Envir</i>	This is a group of functions that sets the way the terminal responds to you in: <ul style="list-style-type: none"><li>• clipping options</li><li>• prompting</li><li>• bell operation</li><li>• default menu level</li><li>• auto-highlighting.</li></ul>
<i>Help</i>	Gives access to the online documentation. See major option HELP for further details.
<i>Abandn</i>	Quits the current operation and returns you to the top level menu.
<i>Visib</i>	Makes strings, objects, or whole models invisible or visible, according to choice.
<i>Status</i>	Displays a range of interrogation functions.
<i>Sheet</i>	Gives access to one of two drawing sheet identification/selection menus.

### Graphics environment settings

When the Environment box is selected from the static menu area a list of settings are displayed which refer to different aspects of the environment:

IMMENUT.DAT, GENEN

Clipping options
Bell operation
Minor option return
Auto highlight switch
Window definition method
Window display
SAME function switch
Field level highlight
Replay PAUSE switch
Replay LOCATE switch

**Clipping options:** provides access to those options which set up and modify a DPF for use with major option CLIP.

**Bell operation:** offers the selection Ring on input or error, or Ring on error only.

Stay at field level is a toggle between Minor option return and Stay at field level.

**Stay at field level:** after each proceed the system will return you to the current menu. If Field level highlight is also set, you will be prompted at the next mandatory field.

**Minor option return:** after each proceed, the system will return you to the options menu to select a new option.

**Auto highlight switch:** if set automatically prompts at the next mandatory field. It may be changed at any time by selecting the Auto highlight box at the bottom of the Scrolling Menu area.

**Window definition method:** offers the selection Opposite corners, Bottom Left + Top Left + Length, or Bottom Left + Bottom Right + Width.

**Window display:** allows you to select Immediate zoom when a window has been defined.

**SAME function switch:** allows you to set Keyboard or SAME function menu.

**Field level highlight:** if set will prompt at the next mandatory field. Only relevant if Stay at field level set.

**Replay PAUSE switch:** allows you to select the Pause switch method. The selections are; Pause on pause record, Pause after any pick, or ignore all pauses.

◇ *Pauses can be placed into the log file by selecting the MOSS banner in the top right hand corner of the IGMODE screen.*

**Replay LOCATOR switch:** allows you to select the Locator switch method. The selections are; Prompt for new locator, or Continue with replay. If you select prompt for new locator, when you replay a MOSS session you are given the opportunity to modify coordinates which were input during the original session.

## Clipping options

### IMMENUT.DAT, GNUMOD

This option sets up the environment for elements which are to be processed by major option CLIP. For details of major option CLIP, refer to Chapter 3.

Element status (T)
Create polygons (T)
Create text boxes (T)
Box horiz gap (ratio)
Box vert gap (ratio)

**Element status** is a toggle which determines the clip status of all subsequently created elements.

A permanent element is not erased if it is intersected by a clip polygon.

An erasable element is fully or partially erased if it is intersected by a clip polygon. Only those portions of the element which lie within the clip polygon are erased.

**Create polygons** is a toggle which determines whether subsequent elements are created as clip polygons.

A clip polygon erases any part of an erasable element which lies within its boundary. The erase operation is carried out by major option CLIP, which processes all clip polygons and creates a clipped DPF.

If a clip polygon is created as erasable, it will still remove erasable elements lying within its boundary, but it may itself be partially or fully erased by any other clip polygon which crosses its boundary.

**Create text boxes** is a toggle which determines whether text created as a clip polygon is drawn with a bounding box or not.

**Box horiz gap** is a ratio which defines the gap between text and the sides of its bounding box. The ratio is a multiple of the current text height.

**Box vert gap** is a ratio which defines the gap between text and the top and bottom of its bounding box. The ratio is a multiple of the current text height.

## Sheet

This menu will appear if the Sheet box is selected and there is only one sheet in the current Draw Picture File (DPF)

**IMMENUT.DAT,**

<b>Current sheet number</b>
<b>Redisplay current sheet</b>

This menu will appear if the Sheet box is selected and there is more than one sheet in the current Draw Picture File (DPF)

**IMMENUT.DAT, GENSH**

<b>Current sheet number</b>
<b>First sheet</b>
<b>Next sheet</b>
<b>Sequential sheet number</b>
<b>X / Y sheet number</b>
<b>Redisplay current sheet</b>

## Status

Status may be selected at any time whilst in graphics. It allows you to obtain

- information about any of the elements currently displayed on the screen
- information about the operating environment.

It is a passive option in that the information obtained may be viewed but not changed.

### IMMENUT.DAT, GENST

Show current DPF name
Show current MOSS models
Show current IG status
Show current meshes
Give an X/Y location
Give element information
Give dist.grad information
Give point information
Give cadastre information
Give curve through 3 pts.

Selection of the required option will provide the information, or prompt you to select an object, element, point or model currently being displayed so that the information may be generated.

## MovCop

Elements which are not strings and objects which do not contain strings may be moved or copied using MovCop. A common use of this is when a company logo or a north symbol has been built up as an object and positioned on a drawing. MovCop may be used to change the position.

If you select MovCop, you will be prompted to identify the element or object to be moved or copied. You will then be prompted for the point to be used as the origin. This point may be anywhere in the graphics area, although normally you would choose the bottom left or top right of the element or object. The next prompt is for the destination coordinates, and the origin is mapped on to the destination point without rotation.

MovCop may also be used to transfer elements between objects and to rotate symbols.

### IMMENUT.DAT, GENMV

<b>Move object on drawing</b>
<b>Move element on drawing</b>
<b>Manipulate text on drawing</b>
<b>Copy object</b>
<b>Copy element (same object)</b>
<b>Copy element (diff object)</b>
<b>Transfer element to object</b>
<b>Rotate symbol (object)</b>
<b>Rotate symbol (element)</b>
<b>Open/close object</b>

Open/close object may be used to create an object and close it when elements have been added to the object. For a further description of objects, refer to the section 'Models and the DPF' in this chapter.

**Manipulate text on drawing**

This option allows you to rotate text around a point in either direction.

IMMENUT.DAT, GNMVTX

Element label
Text content
X coord
Y coord
Rotate anti-clockwise
Rotate clockwise
Rotation angle increment
Rotation point (T)
Delete

**Rotation point:** is a toggle which selects the point about which the text is to be rotated.

- LB is the bottom left edge of the text
- CC is the horizontal and vertical centre
- RT is the top right edge
- DP is the decimal point.

**Rotation angle increment** allows you to change the increment from the default of 5.000 degrees.

**Window selection**

Window			Keyboard							Clear	
1	2	3	4	5	6	7	8	9	C	A	

IMBOXES.DAT

**Figure 2 - 4 Window selection**

The window selection group mostly controls windowing, but also activates the keyboard, and the Clear command.

*Window* Allows you to select and/or define display windows. This allows optimum display scales to be used when working to

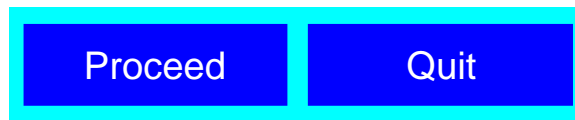
fine limits by enlarging a small area to fill the display. The three methods of definition are, by specifying opposite corners, by selecting the window centre point and using the currently defined window scale (C), and by selecting the window centre point and using actual hard copy scale (A).

*Keyboard* Allows you to activate the keyboard for entry of alphanumeric data. Control is returned to the mouse cursor only when the data followed by [Return] has been entered.

*Clear* Returns you to the previous decision-branch in the menu tree.

## Proceed /Quit

IMBOXES.DAT



**Figure 2 - 5 Proceed/Quit**

Proceed/Quit is a simple two–box choice:

*Proceed* Runs the option using the data just set up.

*Quit* Ignore the data just set up and revert to the previous position.

**GENSH**

## The scrolling menu

The scrolling menu acts as a window: at any one time it displays part of a branch of a menu tree. The tree can be either of the static menu or of a MOSS option menu. Your previous action(s) determines which of these trees the scrolling menu calls up, and which level of which branch it displays. If the branch has too many menu items to display at once (this is the case only with certain menus) you can scroll the off–screen ones into view; hence the name scrolling menu.



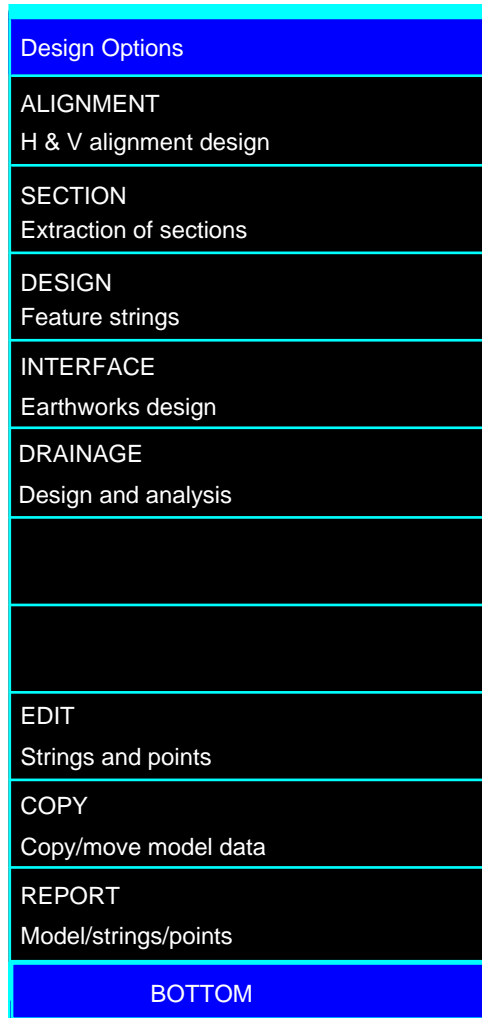
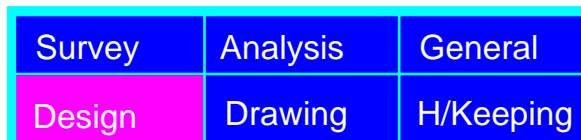


Figure 2 - 6 The scrolling menu

## The selection method menu

When you first enter graphics you will see:



IMBOXES.DAT

Figure 2 - 7 The selection method menu

Selecting any of the boxes Survey, Analysis, General, Design, Drawing or Housekeeping will display the appropriate menu in the scrolling menu area.

For many major options, the above major option groupings are overwritten by the selection method menu. This menu enables you to change the method of selecting information graphically.

Chief among these are model selection methods (MSMs) and point selection methods (PSMs). See 'Graphics selection methods' for further details.

- ◇ *if the directory you are working in contains a DRAW.DPF file DESIGN will be highlit and the scrolling menu area will contain the DESIGN options.*
- ◇ *if the directory you are working in does not contain a DRAW.DPF file DRAWING will be highlit and the scrolling menu area will contain the DRAWING options.*

## The dynamic menu

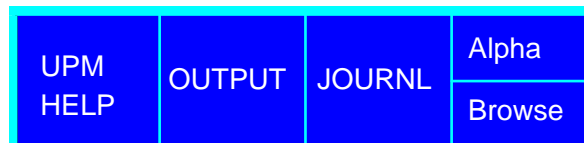
When you first enter graphics the dynamic menu allows you to select

Input	data from file
Output	data to file/device
Journal	switch journal logging
Alpha	view the non graphics window
Browse	turn off the graphic window and view the non graphic window. Allows messages that have been written to be viewed. 'Hit return to continue' returns you to the graphic window.
UPM	when selected the scrolling menu area is blanked and a UPM selection method choice is given in the PSM/MSM area. You can select the UPM using Keyboard, List or List and Mask.
Linemode	change to Linemode
Finish	exit MOSS

As you change major options so the dynamic menu content changes. The choices offered are always appropriate to your current activity in MOSS. For example FINISH will only be available when you are not within a major option.

### UPM Help

Throughout the operation of a UPM in IGmode, the Dynamic menu area will contain the selection UPM Help.



UPM Help is provided as an integral part of the UPM.

# Linemode

We return to linemode because it's the most basic mode. The underlying structure of MOSS's option commands is very clear in it, which makes it a useful vehicle for explaining the command structure. Also MOSS processes data fastest in linemode because it's not slowed by processing and displaying menus and other graphical features. This makes it the best mode for small or simple tasks.

## Command structure

### Major options

The format of a line of data using a major option in linemode is:

```
MAJOR , MODEL1 , MODEL2
```

MAJOR is the name of the function to be applied; for example, REPORT. MOSS will access data from MODEL 1 and MODEL 2.

- ◇ *Major option names are meaningful and indicate facilities available*
- ◇ *Major option names may be abbreviated to four characters. For example SECT is recognised as SECTION.*

### Model name

You have freedom to name the models you are working with and each model name can be up to 26 characters. For example:

```
CREATE, HORSHAM PROPOSED DESIGN
```

This would create a model called HORSHAM PROPOSED DESIGN in the MOSS model file.

If you already have a model containing information you may wish to copy it into the model you have just created. For example:

```
COPY, HORSHAM EXISTING DESIGN, HORSHAM PROPOSED DESIGN
```

This would invoke major option COPY and signify that the model to be copied from is HORSHAM EXISTING DESIGN, and the model to be copied to is HORSHAM PROPOSED DESIGN.

In some cases a third model may be required and if so a second major option line is required. For example:

```
SECTION, HORSHAM BASE MODEL, HORSHAM DESIGN MODEL  
SECTION, HORSHAM SECTION MODEL
```

- ◇ *Model names are user defined and may be up to 26 characters*
- ◇ *In graphics mode, if you define a model which does not exist, you will be given the opportunity to automatically create it.*
- ◇ *Some major options do not need a model name to be specified.*

## Minor options

Minor option data consists of the minor option number followed by up to ten other fields of data:

```
option, field 1, field 2, .....field 10.
```

Option is always a three-digit number.

Fields 1, 2 and 3 are each four alphanumeric characters.

Fields 4 to 10 are numeric data values.

Each of the fields are specific to the option being invoked though there is a regular pattern throughout the system.

Wherever possible a particular field is used for the same type of data. Their most common uses are:

1	Existing or reference string label
2	Subsidiary string label
3	New or amended string label
5 & 6	Start point on reference string
7	
8 & 9	End point on reference string
10	

The use of fields 7 and 10 depends upon the option.

◇ *Where a field is not used, ie it remains blank, it is excluded from the documentation.*

## Example

```
DESIGN, HORSHAM ROAD MODEL  
100, MAST, , ICL1, , 0.0, , -2.0, 150.0
```

This is interpreted by MOSS as :

Carry out some **DESIGN** work on the **HORSHAM ROAD MODEL**.

Apply minor option **100**, (which creates a string parallel to one already in existence).

The string to design from is called **MAST** and the one to create is **ICL1**.

The string ICL1 will be offset **-2** (that is, to the left by **2.0** model units).

## Free format

In the early days of MOSS the ten fields of the minor option data were based on the fixed columns of the input data sheets that were commonly used at the time. Nowadays it's more usual to use linemode in free format.

In free format each line of data consists of a continuous string of characters, with the data for each field separated by commas from the next field. A blank field, therefore, is represented by two consecutive commas. You don't need to type any commas for fields following the last non blank field.

```
DESIGN, ROAD MODEL  
100, MAST, , ICL1, , 0.0, -2.0, 100.0
```

An added advantage of free format is that data is automatically right justified in a field when interpreted; thus the previous example could be typed as follows:

```
DESIGN,ROAD MODEL  
100,MAST,,ICL1,,0,, -2,100
```

- ◇ *Fixed and free format must not be mixed on one line.*
- ◇ *No line can exceed 80 characters, and continuation lines are not provided*
- ◇ *If too many characters are specified for a given field the correct number of characters is taken, starting from the leftmost. For example:*

```
100,MASTER,,ICL1,,0,, -2,100
```

would result in

```
100,MAST,,ICL1,,0,, -2,100
```

- ◇ *Free format can be used in all major options except DIGIT and GENIO.*

### Field number format

A further facility in free format is the ability to assign data to a specific field. You do this by typing in sequence:

the field number      an '=' character      and the data value.

For example: 5 = 0.0 This will place a value of 0.0 in field 5.

Field number format avoids having to repeat commas.

For example: 567,MAST,,,,,,,,,1.0 can be represented as

```
567,MAST,10=1.0
```

This is called field number format. Fields specified by number may appear in any order and may even be repeated, overwriting the previous content of the field allowing faulty data to be corrected. (Data items following fields specified by numbers are assumed to follow in sequence, unless another field number is specified.)

Field number format is particularly useful in terminal based systems.

Examples of field number format data are:

```
100,ICL1,3=OCL1,5=250,300,-6.0,280,305  
004,3=ABCD
```

The following lines all input identical data in linemode:

```
009,X001,,BDRY,,,5.0,,,20.0  
009,1=X001,,BDRY,6=5.0,9=20.0  
009,6=5.0,9=20.0,1=X001,3=BDRY
```

## Macros

If you frequently apply the same sequence of minor options but with varying data, before you start a particular job you can group options into macro-options (or 'macros' for short). You invoke this set of data by typing the name of the macro, followed by the data values you wish to apply. MOSS then executes the group of options in sequence, inserting the current data into the data fields as appropriate. This eliminates time consuming and error prone typing.

Macros are useful for generating standard style drawings.

### Example

To produce a long section drawing of a string LSEC relative to a master string REFS, with a horizontal scale of 1:500 and a vertical scale of 1:100, using the macro LONGDRAW:

```
DRAW, SECTION MODEL, DESIGN MODEL  
900, LONGDRAW  
LR=REFS, LB=LSEC, HS=500, VS=100  
999
```

Chapter 3 details the use of macros in major option DRAW.

Chapter 13 details the creation and use of macros for Customising MOSS.

## Models and the DPF

### Definitions

### Strings and points

MOSS holds all data as points, within strings, within models, within a model file.

A **point** is held as a set of dimensions that are associated with each other. For example, on a contour, a point is just two dimensions (X,Y) and the level of the contour is held at the front of the string because it is common to all points on the string.

A point can have any number of dimensions, depending upon how much information needs to be recorded in addition to its position.

If you imagine that each point is joined to its predecessor and successor by straight or curve-fitted lines, then you have the concept of a **string**. In MOSS all data is held as strings, some two-dimensional, some three-dimensional, some more. These different string types are used to represent particular features, such as highway and railway centrelines, survey stations, etc.

Within any model there are often natural groups of entities. These entities may be grouped together into an **object** and given a name so that operations may be carried out on the object.

## Objects

Objects may include strings, annotation, enhancement boxes etc. Drawing symbols for north signs, or boxed annotation giving curve details are two examples which fall into this category.

## Elements and Items

The components of each object are referred to as **elements** which may or may not be strings. Examples of elements which are not strings include frames, grids and titles.

Elements may be subdivided into **items**. For example, in a string with chainage annotation, each individual piece of text is an item. Other examples of items include cadastral symbols and macrosymbol annotation on strings.

## The modelfile and the DPF

The **model file** stores the up to date surface representation of the scheme under design. Any change you make to a model such as deleting a string, or generating a new one updates the model file.

When producing drawings, an ancillary file is generated containing both model information extracted from the model file, and graphical data. This file is called the **Draw Picture File (DPF)**. It contains structured data associating line styles, colours and scales to the engineering data held on the modelfile. The DPF is the basis of the screen representation of the model data, and the graphics mode of data input relies on this. The DPF is also used for non interactive working: DISPLAY uses the DPF to preview drawings, and PLOTTER uses the DPF to produce a hard copy plot of the drawing.

A second type of file known as a clipped DPF can be created from the DPF. This file contains only the lines, styles, colours and scales required to display or generate a hard copy of the data. The DPF cannot be used to interact with the model.

Another type of picture file used in MOSS is the **Raster Picture File (RPF)**. The RPF is the screen representation of image data stored in a TIFF file. Images held in the RPF are typically used as backcloths on to which model information may be drawn.

## Model names and types

Each model in the model file is identified by a model name, specified by the user. Model names can contain any alphanumeric character but must be unique within the first 26 characters.

The model type is a three or four letter tag appended to a model name and is used to differentiate between different types of models. Model typing allows non-standard information to be held on the model file within particular model types.

It is not possible to have different model types associated with the same model name.

For example:

```
modelname9012345678901234567
modelname9012345678901234567GDS
modelname9012345678901234567TRIA
modelname9012345678901234567EDS
modelname9012345678901234567DRAI
```

cannot co-exist because search routines will not necessarily find the correct model type tag for the current major option.

The following model types are used -

**TRIA** - triangulation models created by major option TRIANGLE. This tag allows maximum flexibility in using the triangulation stored on the model file for other analysis. The reason for the model file type tag is that the information held in this type of model file cannot be simply interpreted as points within strings.

**DRAI** - drainage models. These models can only be accessed from within DRAINAGE design.

**EDS** - EPIC datastore. Major option VISUALISE creates these special models.

**GDS** - ALIGNMENT Geometry datastore. This model type is used to store details of alignments as a job progresses and between jobs.

**TRF** - IDIGIT transformation model. This model type is used by a single model named 'IDIGIT TRANSFORMATION MODEL'. See major option IDIGIT for further details.

- ◇ *Standard models are assumed to have a blank model type extension.*
- ◇ *Temporary models (32 dots and 32 dashes) still exist and are dealt with automatically.*

### Use of model types

The user never needs to type the model type.

Whenever a particular model type is required the appropriate extension is either added (for new models) or found automatically from the model file (for existing models).

The model types are indicated with REPORT minor option 990.



Many options within MOSS require a particular model type ie options 177/178 within SECTION require a TRIA type model for section threading. General major options DELETE, RENAME, COMPRESS, SECURE, FREE, ALIAS, ARCHIVE, RETRIEVE and ERASE accept any model type.

## String labelling

All strings are identified by a four character label unique to the model in which the strings are stored. A label consists of four characters, either alphabetic or numeric, although blanks may not be used. The choice of string labels is usually at the user's discretion, although a pre-defined convention exists which is particularly useful for string selection and drawing.

- ◇ *Lower case characters are not permitted for string labels. MOSS automatically converts lower case characters to upper case characters for the definition of string labels.*

## Partial labels

Partial labels may be used to select an easily referenced group or category of strings. For example, using the standard convention, H can be used to select all hedge strings. This approach has the following advantages -

- automatic detail interpretation within major option DRAW
- ability to include/exclude all hedge strings
- ability to select all hedge strings to change their colour or style of presentation.

## Masking

String masking is used to include or exclude strings from selected operations. The following rules are used:

- Where a partial label 'B ' is specified labels included or excluded will be those with a character B in the most significant place. ie B000.....BZZZ.
- Where a partial label 'BB ' is specified labels included or excluded will be those with a character B in the two most significant places ie BB00.....BBZZ.
- Where a partial label 'BBB ' is specified labels included or excluded will be those with a character B in the three most significant places ie BBB0.....BBBZ.
- Where a partial label 'BBBB' is specified labels included or excluded will be those with a character B in all places ie BBBB a single specific label.
- Where a partial label ' B' is specified labels included or excluded will be those with a character B in the least significant place ie 000B.....ZZZB.
- Where a partial label ' B B' is specified labels included or excluded will be as follows -

0B0B;0B1B....  
0BZB;0B1B....  
0B9B;0BZB....  
1BZB;9BZB....  
ABZB;ZBZB.

## Conventions

There are certain string labelling conventions that are recommended for use throughout the system which, if used, minimise the amount of information to be specified to major option DRAW for the production of drawings with standard detail interpretation.

The conventions apply to the first character of the string label as follows:-

D	Ditch
F	Fence
G	Geometry string
H	Hedge
I	Interface
L	Level points (Spot levels)
M	Master alignment
P	Point strings. The second and third characters may be used for further definition with the exception of PSSA which is used for survey stations, for example: PGU            Gullies PEP            Electricity pole PTP            Telegraph pole
V	Verge

You are advised to define and maintain a string labelling convention. The labelling convention has most relevance to a survey model which may contain many string types. The recommended labelling method uses the initial character to define the string type, and the second and third characters to identify subsets of the string type. For example:

H	Hedge
HL	Hedge large
HS	Hedge small
BR	Building to the right
BL	Building to the left
PLS 1	
.	Pole Lamp Standard
.	where 1 to 9 defines size
.	1 = smallest 9 = largest
PLS 9	

## Automatic labelling

Certain options generate labels automatically, particularly those that process bulk input data from air or ground surveys. Within these options partial labels may be defined and the system will complete the label. Where

strings are being added to a model already containing strings the initially assigned label may not be unique and must be relabelled.

When new strings are added to the model, checks are carried out and action taken as follows -

- Labels in the original model remain unchanged.
- Complete and unique new string labels remain unchanged.
- Complete, duplicate new labels are relabelled to the next available label.
- P strings are never relabelled but always appended to their existing string.

The conventions governing the allocation of string labels are as follows:

- Any partial or totally blank label is completed by overlaying the label onto the label 0000. Thus X\_ \_ \_ is completed as X000 whereas \_X\_X is completed as 0X0X. By this device all labels become full four characters though they are not necessarily unique.
- Any non-unique label is relabelled by incrementing it until it becomes unique. The label is incremented according to the order 0-9, A-Z, for example  
0000;0001..... 0009;000A..... 000Z;0010 up to ZZZ0;ZZZ1....  
ZZZ9;ZZZA.... ZZZY;ZZZZ.

### Example

Consider an existing model containing:

0001, 0002, 0003, 0004, 0005, 0006, 0007, 0008  
A001, A005, A009, A010, A011, A013  
PGU1, PTR1, PTR3 Z001, X099, X100, X999

Add strings as follows (b=blank):

bbbb, bbbb, Xbbb, H001, PTRb, PTRb, ABCD, ABCD  
XYZW, A001, A002, A003, X002, X003, X004, H003, H0202, H001, PTR3

These would be stored in the model as follows:

0000, 0009, X000, H001, PTR0, PTR2, ABCD, ABCE  
XYZW, A004, A002, A003, X002, X003, X004, H003, H002, H004, PTR3

### Reserved labels

The label TTTT should not be specified in any minor option data as this label is used by the program when calculating temporary strings.

### Sub-references

For some types of string, a sub-reference is allocated in order to give some information about how the string was generated.

For example, a section string has a sub-reference which indicates the reference string on which the sections are based. Similarly, a geometry string has a sub-reference which indicates the associated master string.

## Standard Point Reference Data (SPRD)

A variety of methods is provided to define a point within a string. The points can either be an actual point within a string (exact point) or a non-exact point. The alternative methods of defining the start and end points are as follows:

### Point sequence number

A point sequence number is the sequence number of the point from the beginning of the string as stored. The sequence number can be determined from the output of the REPORT option or the point sequence numbers may be drawn using major option DRAW. Note that if a point is deleted from a string all the subsequent points are renumbered immediately.

Point sequence numbers are specified in Field 6 (start point) or Field 9 (end point) of a minor option.

### XY coordinates

Exact X and Y coordinates may be specified (found to within the location tolerance). If a non-exact point is specified the associated point is found by dropping a normal from the point on to the curve-fit string.

The X and Y coordinates are specified in Fields 5 & 6 (start point) or Fields 8 & 9 (end point) of a minor option.

### Chainage

For a six dimensional alignment string it is possible to define a point on a string by chainage. An exact chainage point is found to within the location tolerance. If a non-exact chainage is specified the associated point is determined on the curve fit string.

The chainages are specified in Field 5 (start point) and Field 8 (end point) of a minor option.

### SPRD conventions

The following conventions are adopted when specifying SPRD:

- If Fields 5 and 6 are left blank, the start point is taken to be the first point on the specified string.
- If Fields 8 and 9 are left blank, the end point is taken to be the last point on the specified string.
- If Field 6 or Field 9 is typed as -1 then the last point of the specified string is taken.
- If Field 6 or Field 9 is typed as -2 then the penultimate point of the specified string is taken (major option DRAW geometry strings only).
- The end point may be defined by a different method to the start point but must not be the same point.

## String types

String type	Label	Sub ref	No. of dims	Dimension content (see key below)
Cadastre string	P_---	SHEE orNOR T	10	X,Y,Z,SRB,SPN,FC,CPN
Contour string	----	Level	2	X,Y
Cross section string	----	Ref String Label	5	X,Y,Z,OFF,INT
Design/edit string	----		3	X,Y,Z
Drainage string	see major option DRAINAGE			
Geometry string	G_---	M_---	12	X,Y,Z,CH,BRG,RAD,GRAD,M,HP,VP,HE,VE
Interface cut string	----	INTC	5	X,Y,Z,OFF,BRG
Interface fill string	----	INTF	5	X,Y,Z,OFF,BRG
Long section string (minor option 170)	----	L170	5	X,Y,Z,OFF,INT
Long section string (others)	----	Ref String Label	5	X,Y,Z,OFF,INT
Mass haul string	----	----	10	X,Y,Z,CH,VFC,VCC,V1,V2,V3,V4
Master string	M_---	G_---	6	X,Y,Z,CH,BRG,RAD
OSPP string	----	----	2	X,Y
Point string	P_---		3	X,Y,Z
Scheme volume string	----	----	10	X,Y,Z,CH,VF,VC
Survey string (no curve fitting)	----		3	X,Y,Z
Survey string (with curve fitting)	----		3	X,Y,Z
Survey station string	PSSA	SSTA	4	X,Y,Z,STN
Survey observation string	----	----	4	X,Y,Z,OBS
Text string	*_---		Up to 15	X,Y,HT,ANG,TEXT
Triangulation string	see major option GENIO			
Visibility string	----	VISI	10	XREF,YREF,XEYE,YEYE,XTAR,YTAR,CH,VDIS,VMIN,VDEF
Volume string	----	VOLM	10	X,Y,Z,CH,VF,VC (Dims 7,8,9,10 not used)
End area string	----	ENDA	10	X,Y,Z,CH,SAC,SAF, (Dims 7,8,9,10 not used)

### Key:

—	Alphanumeric character	SRB	Symbol reference bearing
ANG	Angle	VDEF	Visibility deficiency
BRG	Bearing	VDIS	Visibility distance
CH	Chainage	VC	Cut volume
CPN	Cadastral point number	VE	Vertical element name
FC	Feature code	VF	Fill volume
GRAD	Gradient	VFC	Cumulative fill volume
HE	Horizontal element name	VMIN	Minimum visibility distance
HP	Horizontal point code	Vn	Additional materials volumes
HT	Text height	VP	Vertical point code
INT	String intersection	X	X coordinate
M	M value	Y	Y coordinate
OBS	Observation number	Z	Z coordinate
OFF	Offset	XREF	X coordinate (reference)
RAD	Radius	YREF	Y coordinate (reference)
SAC	Sectional area of cut	XEYE	X coordinate (eye)
SAF	Sectional area of fill	YEYE	Y coordinate (eye)
SPN	Survey point number	XTAR	X coordinate (target)
STN	Survey station label	YTAR	Y coordinate (target)
VCC	Cumulative cut volume		

## Cadastre strings

This string type provides a simple means to add cadastre information to a MOSS drawing. The cadastre information can be either text or a macrosymbol or both.

The cadastre string is a point string with a subreference of SHEE or NORT. Each point of the string defines a standard coordinate at which unique cadastre information can be added, changed or deleted.

The subreferences SHEE or NORT indicate the reference for angular rotation of cadastre symbols as being ‘the left hand sheet edge’ or ‘north’.

The unique cadastre information defined for each point of the string is held as additional dimensions and includes:

**X, Y, and Z coordinate** as the survey point string.

**Symbol reference bearing** defines the angular rotation of the macrosymbol from the reference SHEE or NORT.

**Survey point number** allows a maximum of eight alphanumeric characters to be assigned.

**Point feature code** defines the nature of the point and the macrosymbol to be used for drawing interpretation. The point feature code is a maximum of four alphanumeric characters.

**Cadastre point number** allows a maximum of sixteen alphanumeric characters to be assigned.

The cadastre string can be manipulated by major options COPY, DRAW, EDIT, GENIO, IGMODE and REPORT.

## Geometry strings

A geometry string is identified by the initial character ‘G’ in its label, and its subreference is the label of the master string to which it is associated.

Geometry strings have 12 dimensions and store information about an alignment, for example, the horizontal and vertical tangent points of a string. The geometry string holds all the information necessary to regenerate the master string, together with additional information which may be used to annotate drawings. A geometry string code is used by major option DRAW to identify which information is to be extracted from the geometry string and used for subsequent annotation.

Major option ALIGNMENT automatically generates a geometry string when a master string is created. If the geometry string only contains horizontal information then the resulting master string contains null levels throughout.

The dimensions of the geometry string are listed in the table 'String types'. The interpretation of the codes in dimension 9 of the geometry string is shown below.

**Horizontal tangent point codes**

Element Before	Code	Element After
None	PBC	Arc
None	PBT	Straight
Straight	PC	Arc
Arc	PT	Straight
Straight	TS	Spiral
Arc	CS	Spiral
Spiral	SC	Arc
Spiral	ST	Straight
Arc	PCC	Arc
Arc	PRC	Arc
Spiral	SS	Spiral
Arc	PAC	None
Straight	PAT	None

◇ *The codes PBC etc may be replaced by an alternative National code by editing the appropriate section of the parameter file.*

The interpretation of the codes in dimension 10 of the geometry string is shown below.

**Vertical tangent point codes**

Element Before	Code	Element After	Description
None	PBC	Curve	
None	PBT	Grade	
Grade	PC	Curve	
Curve	PT	Grade	
Curve	PCC	Curve	(same sense)
Curve	PRC	Curve	(opposite sense)

Curve	PAC	None	
Grade	PAT	None	
Curve	VX	Curve	(high or low point)
Curve	VM	Curve	(middle ordinate point - see below)
Curve	VMX	Curve	(coincident high or low and middle ordinate point)
Grade	TT	Grade	(Version 9 onwards)

- ◇ *Middle ordinate points are points on the alignment perpendicularly above/below where 2 grades separated by a single vertical curve intersect.*
- ◇ *The codes PBC etc may be replaced by an alternative National code by editing the appropriate section of the parameter file.*

### Superelevation

Superelevation is stored in additional points on the geometry string. The first six dimensions of these additional points are the same as those for the horizontal tangent point. Dimensions 7 upwards are used to store superelevation information.

Dimension	Code	Description
7	-	Superelevation (crossfall or cant)
8	-	Design speed
9 (first 2 digits)	XF CA	Crossfall Cant
9 (last 2 digits)	00 02	No design rules Dutch design rules

- ◇ *Crossfall values are stored as a decimal percentage.*
- ◇ *Cant values are stored in metres (metric) or decimal feet (imperial).*



## General information

### Keyboard entry – case sensitivity

You can enter data by the keyboard in both upper and lower case. MOSS will retain and use the 'case' of the data with the following exceptions.

MOSS will automatically convert and store the entry in uppercase if it is shown on the screen in uppercase at the time of entry, irrespective of the typed 'case'. This will happen for the following

- Major option names
  - Minor option data – except
    - minor option 001 when the associated data is text
    - minor option 808 field 3
    - minor option 884 when the associated data is text.
  - Model names
  - String labels
- ◇ *File names may be entered in either case and will be used by the operating system without conversion. For example:*  
*DESIGN.fil*  
*Design.fil*  
*design.fil*  
*are three individual files.*

### Curve fitting

Curve fitting is used in two distinct areas in MOSS.

1. as an environmental option in major option DRAW
2. as a design consideration in analytical MOSS options.

Two styles of curve fitting are available.

3. MOSS style curve fitting.
4. SPLINE style curve fitting.

The use of curve fitting in these two areas is completely separate such that the method of drawing does not affect the methods of calculation.

### **MOSS style curve fitting**

- Based upon circular arcs through 3 successive points.
- throughout a string those links which are exactly circular arcs or straights are correctly simulated whilst transitions are closely approximated.
- throughout any curve fit string there is continuity of both bearing and curvature.

### **SPLINE style curve fitting**

SPLINE curve fitting fits a cubic equation passing through two successive points on a string. Properties of this algorithm are:

- circular arcs, straights and transitions are closely but not precisely generated.
- throughout the string there is continuity of bearing but not of curvature.
- the 'SPLINE' curves tend to be flatter than 'MOSS' CURVES.

### **Curve fitting in DRAW**

Curve fitting is used in DRAW to define the appearance of a string and is set by the 'drawing environment' menu options or with minor option 812. Care should be taken when drawing with curve fitting. Strings generated with spline techniques, ie by major option HCUSP should have sufficient points such that they need not be drawn with spline techniques to obtain the desired curve.

### **Curve fitting in DESIGN**

MOSS curve fitting is used throughout the design and analytical options. Any intersection between curve fitted strings will use MOSS style curve fitting. Certain options eg HCUSP, COPY 064 and EDIT 028 will generate strings using SPLINE techniques.

### **Curve fit indicators**

To ensure that a string with specific curve fitting style is handled correctly by major option DRAW, each string has a curve fit indicator stored within its header information. This indicator may define one of the following:

- 0 defines a string created with no specific curve fit indication.  
A string created prior to the introduction of the indicator.
- 1 defines a string assumed to contain points which require interpretation as straight-line link information.  
A string created without the addition of any curve fit points.

This indicator is used by major option DRAW to suppress curve fitting for the string if detail interpretation is invoked.

The string may be drawn with curve fitting if general curve fitting is invoked and detail interpretation is not used.

- 2 defines a string assumed to contain points which require interpretation as curve fitted links.

The string may be created with curve fit points added in either MOSS or SPLINE style.

Major option DRAW will curve fit the string using MOSS style with either detail interpretation or general curve fitting invoked.

- ◇ *Curve fit indicators are introduced with minor options SURVEY 201 and 202, SURFACE 970 and 971, COPY 064 and 065 and EDIT 028 and 032.*
- ◇ *Curve fit indicators will be preserved throughout major options EDIT, COPY, GENIO and DRAW.*

## Discontinuities

### Linear discontinuity

Strings in a model sometimes require gaps or **linear discontinuities** in order to describe a feature such as a gate in a fence or a break in a hedge. When a linear discontinuity is inserted, the original string is divided into pieces of the same string with the same label.

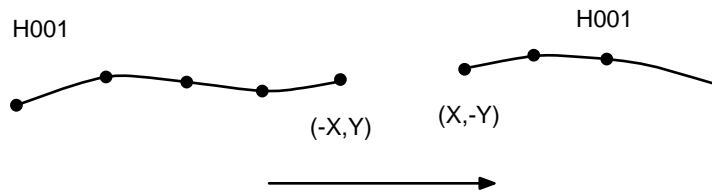


Figure 2 - 8 Linear discontinuity

The first point on the discontinuity is stored in the model with a negative X coordinate and the last point with a negative Y coordinate, as shown in Figure 2 - 8.

### Bearing discontinuity

A string point may be a **bearing discontinuity** if the continuity of bearing is not maintained through the point. It is used when drawing with curve fitting to give an immediate change of direction.

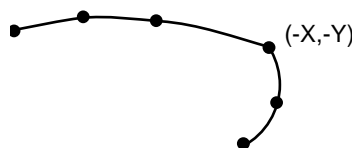


Figure 2 - 9 Bearing discontinuity

A point which is a bearing discontinuity is stored in the model with a negative X and a negative Y coordinate, as shown in Figure 2 - 9.

- ◇ *Linear discontinuities are also bearing discontinuities.*
- ◇ *Bearing discontinuities may be introduced in major options SURVEY, INTERFACE and SURFACE.*
- ◇ *Bearing discontinuities will be preserved throughout major options EDIT, COPY, GENIO and DRAW.*

## Negative coordinates

MOSS supports the use of negative coordinates, provided the parameter file PRMDEF.DAT is set up correctly.

Negative coordinates are achieved by modifying the offset value of X\_OSHIFT and Y\_OSHIFT in the parameter file to be very large positive numbers.

### Theory

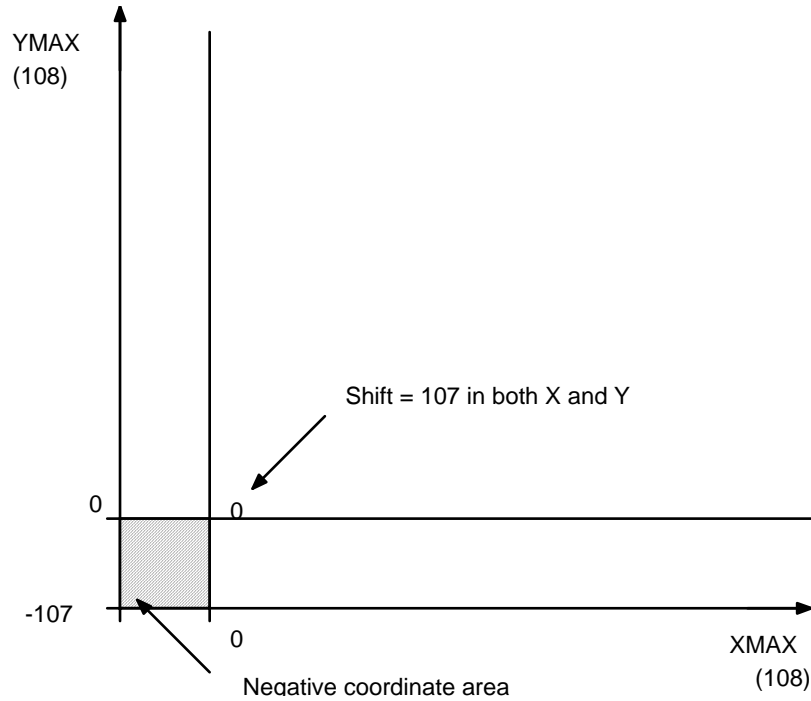
MOSS modelfile coordinate data is stored with the constant X\_OSHIFT and Y\_OSHIFT added.

Whenever MOSS modelfile coordinate data is recalled for use in MOSS the X\_OSHIFT and Y\_OSHIFT offset values are subtracted to give the coordinates that the user is expecting.

Whenever MOSS coordinate data is returned to the modelfile to be stored, the X\_OSHIFT and Y\_OSHIFT offset values are added. This ensures that all stored model coordinates are positive, and allows negative values to indicate discontinuities.

### Method

To use negative coordinates set the value of both X\_OSHIFT and Y\_OSHIFT to, for example, 10 000 000 ( $10^7$ ). This will allow a maximum positive coordinate of 89 999 999 and a minimum coordinate of -10 000 000.



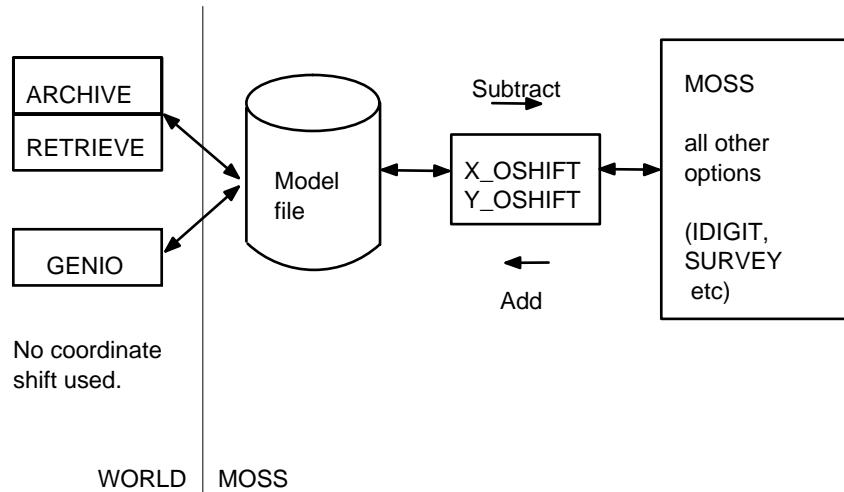
**Figure 2 - 10 Coordinate range**

- ◇ *Once a model file has been initiated and coordinate data stored, do not change the X\_OSHIFT and Y\_OSHIFT values.*  
If you change the X\_OSHIFT and Y\_OSHIFT values the coordinate data offset previously used will be lost.
- ◇ *It is recommended that the same setting for X\_OSHIFT and Y\_OSHIFT is defined and maintained for all your model files.*

**Data exchange**

When model file coordinate data is output via GENIO and ARCHIVE the coordinate data is written with the X\_OSHIFT and Y\_OSHIFT offset as an integral part of the data.

When model file data is input via GENIO or RETRIEVE the coordinate data is read with the X\_OSHIFT and Y\_OSHIFT as an integral part of the data. Clearly the parameter file used to create the model file and the parameter file used to read it must be the same.



**Figure 2 - 11 Model file coordinate handling**

- ◇ *If genuine negative coordinates are to be input via GENIO, use minor option 080 to shift the X and Y coordinates by the same values as X\_OSHIFT and Y\_OSHIFT. When the data is read from the model file, the shift will be reversed and the coordinates returned to their original values.*
- ◇ *Major options SURVEY and IDIGIT handle negative coordinates directly providing the parameter file is set appropriately.*

Add note about standalone programs when this information is available.

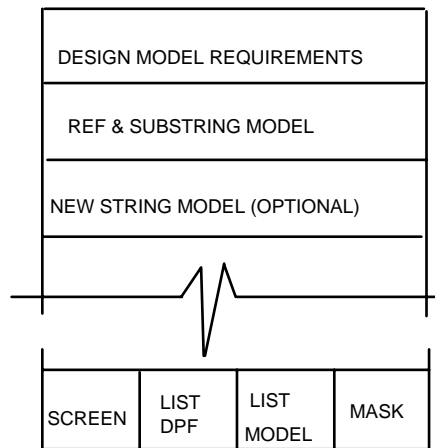
## Graphics selection methods

This section covers the following topics:

- Model selection methods (MSMs)
- String selection methods (SSMs)
- File selection methods (FSMs)
- Point selection methods (PSMs)
- Data selection methods (DSMs)
- Data amendment methods (DAMs)

## Model selection methods

When entering a major option in graphics mode a menu will be displayed enabling you to select either one or two models, as required by the major option.



The four possible methods of selecting a model are displayed in the PSM area.

### SCREEN

This is the default MSM and allows you to select any element in the screen display area. The model name connected with the selected element will be displayed in the SMA (Scrolling Menu Area).

### LIST DPF

When LIST DPF is selected, all the models that are found on the current DPF are displayed in the scrolling menu area. The required model can then be selected from the list, and will be displayed in the SMA.

### LIST MODEL

When LIST MODEL is selected all the models that are found on the model file are displayed in the scrolling menu area. The required model can be then selected from the list.

### MASK

This option allows you to produce a list of model names in the scrolling menu area that satisfy a given mask. The mask character is an asterisk.

For example:

**\*SIMP** will list all model names which **end** in 'SIMP'.

**SIMP\*** or **SIMP** will list model names which **start** in 'SIMP'.

**\*SIMP\*** will list model names which **contain** the characters 'SIMP'.

The required model can be selected from the list in the usual manner.

At any stage in the operation the 'Keyboard' box may be selected and the model name typed in.

When you have selected the models and they are displayed in the SMA, you select PROCEED to take you into the major option.

◇ *In graphics mode, if you define a model which does not exist, you will be given the opportunity to create it.*

## String selection methods

String selection methods in graphics are very straightforward: you either move the cursor to the required string on the screen and click to select, or select Keyboard and type in the name.

## File selection methods

When using certain major options in graphics mode, a menu will be displayed enabling you to select a file, either from a list or using a mask, which is relevant to the option.



◇ *At any stage in the operation the 'Keyboard' box may be selected and the required file name typed in.*

The two possible methods of selecting a file are displayed in the FSM area.

### LIST

When you select LIST, all files in your working directory which are relevant to the option you are using are listed in the scrolling menu area.

For example, when using major option **INPUT**, all files with a **.inp** extension are listed. If you are using UPM in IGmode, all the UPMs available to you will be listed.

Once the files are displayed in the SMA, select the file you require from the list. The option you are using will then be invoked with the file you have selected.

### MASK

When you select MASK, you may enter a file specification for the files you wish to list in the scrolling menu area. The file specification may include any file masking option supported by the operating system. For example, in Unix:

a*	list all files starting with 'a'
*a*	list all files containing an 'a'
?a*	list all files with an 'a' as their second character
[ab]*	list all files starting with 'a' or 'b'
*[c-j]*.inp	list all files containing a letter between 'c' and 'j' (inclusive) with the suffix '.inp'.

Once the files are displayed in the SMA, select the file you require from the list. The option you are using will then be invoked with the file you have selected.



## Point selection methods (PSMs)

Point selection methods (PSMs) are what the term implies: methods you can use to specify points in a ground model or in a design model. There are several methods available, in two main sub-sets depending upon whether you're using major option ALIGNMENT (see Chapter 6), or not.

Using non-ALIGNMENT methods of design for horizontal and vertical design in graphics mode, there are five PSMs; but using these methods with major option ENHANCE there are just two PSMs.

The main graphics PSMs are presented in the PSM area menu display:

POINT	XY	INTS	CONSTR
PTXY	CHAIN	NORM	TRIGXY

### POINT

This is a method for finding an exact point on an existing string. If a string is already highlighted, POINT will identify the nearest point on the string, and you will be shown the point number of the selected point. If you select KEYB then you will have to type in the point sequence number of the point you require and this will then be displayed. If you ask for point number -1, the last point on the string will be selected.

If a string is not already highlighted you will first be prompted to identify the string, after which the same process will be followed, except that in this case the model co-ordinates rather than the point number will be displayed.

The difference between the two approaches (of the string being highlighted or not) is that in the first case both the string and the point number will be used in the subsequent processing, whereas in the second only the model coordinates are used.

### PTXY

This is a method for finding the coordinates of an exact point on an existing string.

The method of use is similar to POINT.

### XY

The actual coordinate position of the cursor, independent of the string, is selected and displayed. If you select KEYB, type in the coordinates.

### INTS

The point selected and displayed is the point of intersection of two strings. For the three prompts, identify both strings and an approximate position for the intersection. You can choose whether to curve fit the strings intersecting one another. If the point displayed is not in the position you expect, it may be because the curve fitting is switched on when it should be off, or vice versa. For each prompt, if you select KEYB you key in the response rather

than using the cursor. If a string is already highlighted then only the second and third prompts will be given.

### CHAIN

To use this PSM you must be referring to a 6D M-string. If a string is already highlighted CHAIN will display the nearest string point with its associated chainage. If you select KEYB, then type in the chainage. A typed chainage need not be an exact string point, whereas a point selected by the cursor will return the chainage as an exact point.

The difference between the two approaches of the string being highlighted or not is that in the first case both the string and the chainage will be used in the subsequent processing ; in the second case only the model coordinates are used.

### NORM

With this PSM, there are three possibilities:

Case 1 finds the point on a string whose normal passes through the cursor position:

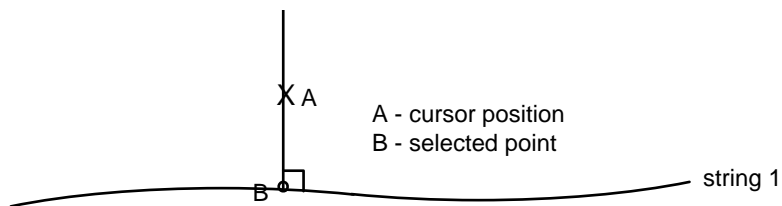


Figure 2 - 12 Example NORM Case 1

Case 2 finds the intersection point on a string intersected by a normal from another passing through an X/Y point in space.

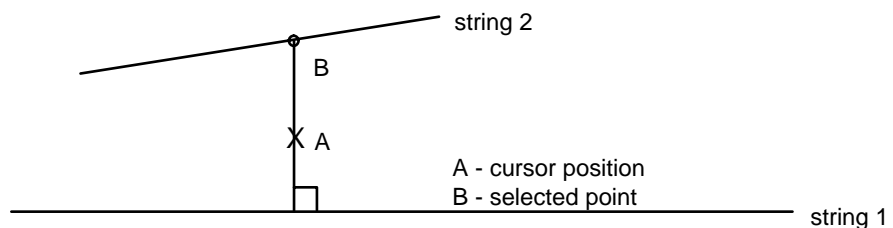


Figure 2 - 13 Example NORM Case 2

Case 3 finds the point on a string intersected by a normal constructed from a point on an alternative string.

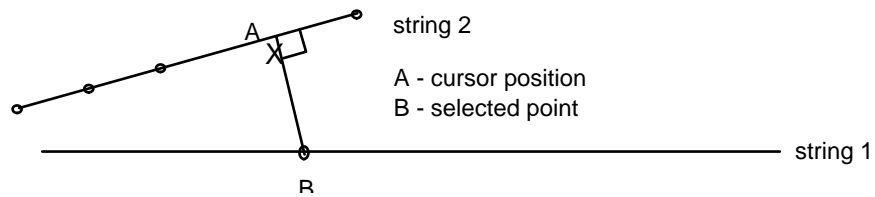


Figure 2 - 14 Example NORM Case 3

All cases have the same prompts:

- P1 the string on which the point is found  
 For case 1 select string 1  
 For case 2 select string 2  
 For case 3 select string 1
- P2 the string onto which a normal is to be dropped. This is string 1 for cases 1 & 2, but string 2 for case 3.
- P3 the cursor position of A.

For identifying the cursor position (point A), all PSMs are valid. Consequently point A could be the intersection of two strings (that is, in cases 1 and 2, A could be selected using X/Y PSM, whereas in case 3, A could be selected using POINT PSM.)

As for other PSMs if the string is already highlighted the first prompt is ignored.

If NORM PSM calculates more than one normal then the point closest to the cursor position will be displayed. The alternative normals are accommodated by employing the NEXT NORM feature in POINT AMEND. This is described in the next section.

## TRIGXY

TRIGXY is a method of obtaining 3D XY and Z information for triangulation. When you select TRIGXY for the first time you will be requested to select the triangulation model and string using standard MSMs. If you pick from the screen both model and string are selected. If you use LIST MODEL, you will have to type in the triangulation string label.

When the PSMs return you may select an XY coordinate, X Y and Z details will be displayed.

- ◇ *To change the current triangulation string, select TRIGXY twice consecutively.*
- ◇ *If you select POINT AMEND, only NSEW options will be available.*

## CONSTRUCT

CONSTRUCT is a method of obtaining a position or an angle from geometrically constructed elements, known as 'constructs'. Information returned may be:

- A point from a single construct

- A point from the intersection of two constructs
- The angle between two line constructs

To obtain a position from a single construct, or from the intersection of two constructs, select CONSTRUCT from the PSM menu. To obtain an angle between two line constructs, select the SAME function by typing 'S' when prompted to do so.

When you select CONSTRUCT from the PSM menu, the following menu is displayed in the scrolling menu area:

**IGGENLT.DAT GEN014**

PSM Construct
Single construct point
Intersection point

Each of the entries in the above menu allows you to build constructs by taking you through a series of menus.

Constructs are only displayed temporarily and are erased as soon as the required coordinates are returned.

Constructs have a direction associated with them, so that standard conventions may be used when specifying offsets and angles. The direction is taken as being from the first point specified to the second.

Single construct point

IGGENLT.DAT GEN015

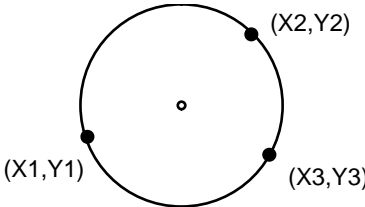
Single construct point
Circle: 3 points
Circle: 2 points & radius
Circle: 2 tangents & rad
Line: divide a line
Line: pt, brg & distance
Line: angle and distance
Line: distance and offset

Select the type of construct you wish to build. Further menus are displayed which enable you to enter the data for your selected construct. At any time, you may amend the construct by respecifying a value and redrawing the construct.

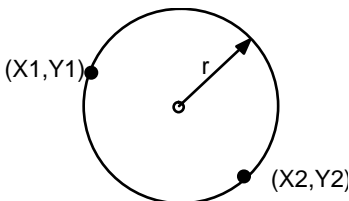
When you have defined a single construct, the construct is displayed and the coordinates of the constructed point are displayed at the top of the screen. Select Proceed to accept the coordinates and return them to the menu field from which you called PSM Construct. Select Quit to reject the coordinates.

The construct is erased once you have accepted or rejected the returned coordinates.

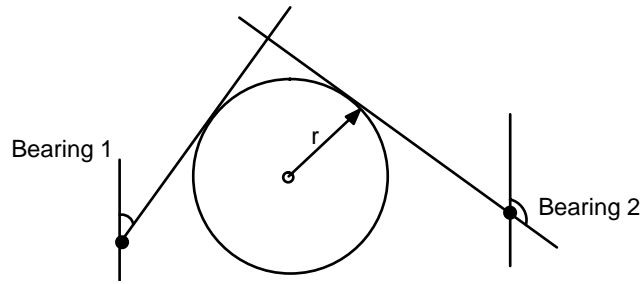
Circle: three points



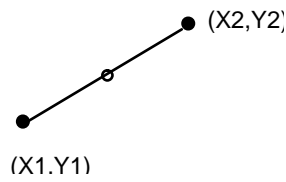
Circle: two points and radius



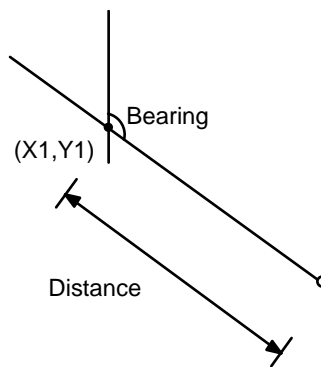
Circle: two tangents and radius



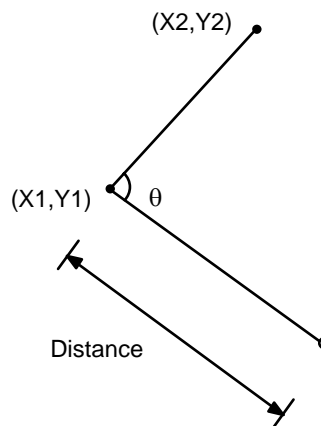
Divide a line (default fraction 0.5)



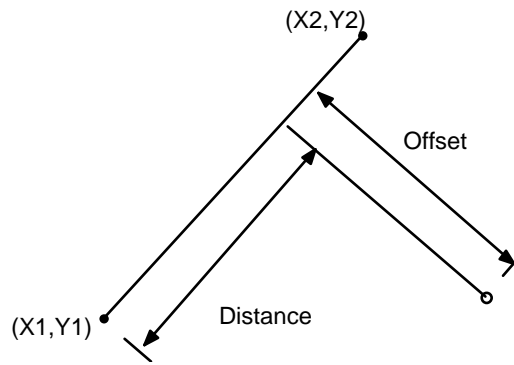
Point, bearing and distance



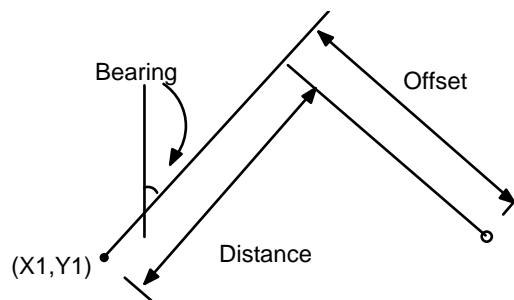
Line, angle and distance



Line, distance and offset  
(using two points)



Line, distance and offset  
(using point and bearing)



Intersection point

IGGENLT.DAT GEN016

Intersection point
Circle: centre & radius
Circle: centre & point
Circle: 3 points
Circle: 2 points & rad
Circle: 2 points on diam
Circle: 2 tangents & rad
Line: 2 pts offset & angle
Line: point and bearing
Line: divide a line

Select the type of construct you wish to build. Further menus are displayed which enable you to enter the data for your selected construct. At any time, you may amend the construct by respecifying a value and redrawing the construct.

For an intersection point to be returned, you must define two constructs.

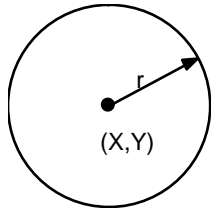
If you build a line construct from another line, you may specify the ratio at which the first line is divided. By default, the line is bisected, but you may specify a value between 0 and 1 to obtain different intervals. If you specify 0, the construct is placed perpendicular to the line at the first point. If you specify 1, the construct is placed at the second point.

Once you have built both constructs, if either of the constructs are circles, you are prompted to select a position near the required intersection point.

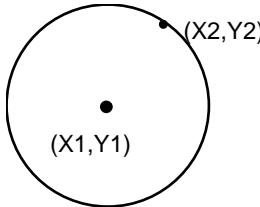
The coordinates of the constructed point are then displayed at the top of the screen. Select Proceed to accept the coordinates and return them to the menu field from which you called PSM Construct. Select Quit to reject the coordinates.

The construct is erased once you have accepted or rejected the returned coordinates.

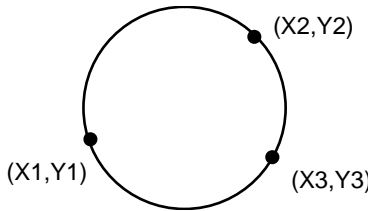
Circle: centre and radius



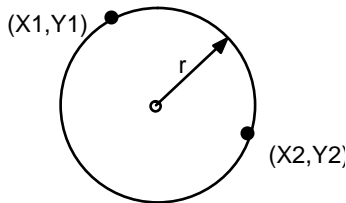
Circle: centre and one point



Circle: three points

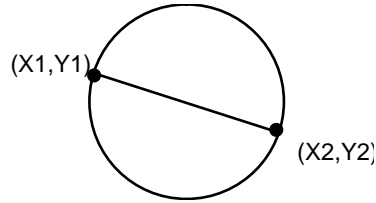


Circle: two points and radius

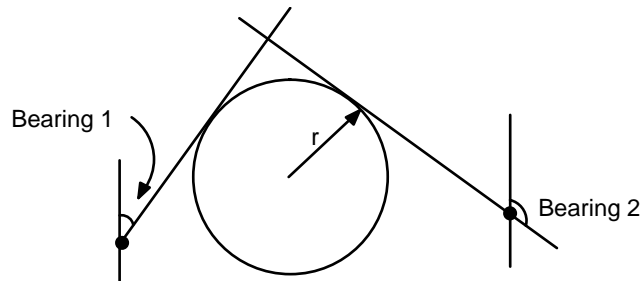


Circle: two points on diameter

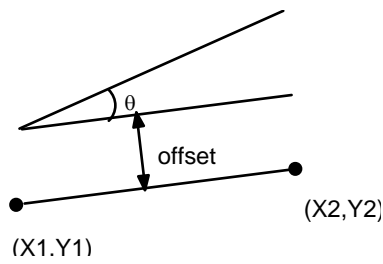




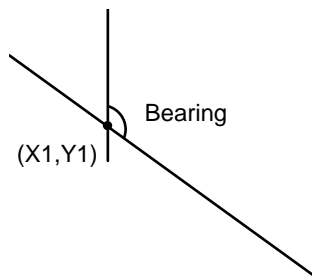
Circle: two tangents and radius



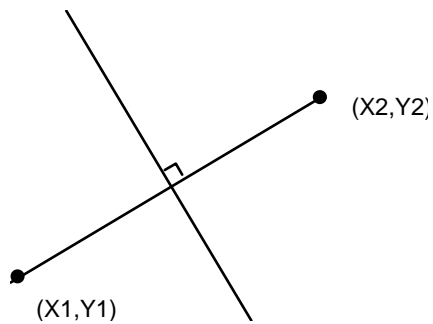
Line: two points, offset and angle



Line: point and bearing



Line: divided by a line



Angle between two lines

iggenlt.dat gen033

Angle between 2 lines
Line 1 pt 1 X/Y
Line 1 pt 2 X/Y
Line 1 bearing
Line 2 pt 1 X/Y
Line 2 pt 2 X/Y
Line 2 bearing
Calculate angle

◇ *Angle constructs are only available by typing 'S'to invoke the SAME function when prompted to do so.*

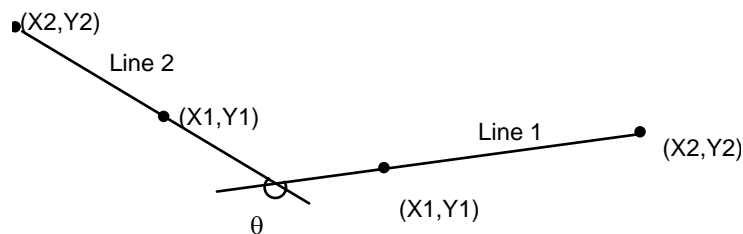
When you define an angle construct, specify the first point and either the second point or the bearing for each line.

At any time, you may amend the construct by respecifying a value and redrawing the construct.

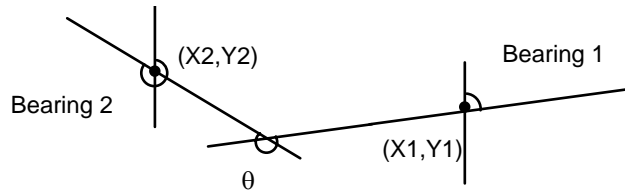
Once defined, the construct is displayed and the angle associated with the construct is displayed at the top of the screen. Select Proceed to accept the angle and return it to the menu field from which you invoked the SAME function . Select Quit to reject the angle.

The construct is erased once you have accepted or rejected the returned coordinates.

Angle: two lines, two points



Angle: two lines, point and bearing



**Major option ENHANCE**

Using major option ENHANCE in non-ALIGNMENT graphics mode there is no need for the sophisticated point selection methods of other options, so a simpler PSM area is displayed:

	XY		
MESH			

**XY**

The actual position of the cursor will be selected. The POINT AMEND functions may be applied to this PSM.

**MESH**

The nearest mesh point to the cursor will be selected. Usually the mesh will have been initialised earlier in the session, and if not a message will be issued.

**Major option ALIGNMENT**

With major option ALIGNMENT more complex data can be input and more sophisticated methods can be adopted. These are presented in Chapter 6.

**Data selection methods**

Some fields allow you to use 'SAME menus' to determine values to be used as input to MOSS. These menus allow you to select an existing point or feature on the display and to extract certain properties of that feature: either the WCB of a point or the distance between two points.

When in graphics and ALIGNMENT horizontal design the following menu will appear:

SAMD	SAMB	SAML	SAMR
------	------	------	------

To invoke these functions you must type in an 'S' when prompted with:

**TYPE IN REQUIRED VALUE OR 'S' TO INVOKE SAME FUNCTION**

If you want the SAME menu to be displayed by default rather than by prompting for keyboard input, an ENVIRONMENT setting can be changed to do this. The 'same menu' selection boxes will then appear in the bottom left of the screen.

**SAMD (Same distance)**

This option allows you to select two points from the screen. The current field may require a length/distance, in which case the distance between the two points will be calculated; or the field may require an angle, in which case the whole circle bearing between the two selected points will be calculated. When entering the SAMD function a PSM will be highlighted which will enable you to use any PSM to select the two points.

**SAMB (Same bearing)**

This option allows you to select a point on a screen feature, using any PSM, to obtain its bearing. PSM's X/Y and INTS will return zero values as a bearing. When using ALIGNMENT, POINT PSM may be used to select the bearing of the start point of an element, whereas this application of POINT PSM is usually invalid.

**SAML/SAMR (Same length and same radius)**

These features are valid only in selecting alignment features: SAML for alignment links only, and SAMR for both alignment links and elements. When selecting either the SAML or SAMR box you will be prompted for a feature to select, from which you want the appropriate value extracted. Unlike SAMD and SAMB these are not PSM fields.

The following SAME menu will appear when using vertical alignment design:

SAMD	SAMG	SAMCP
------	------	-------

**SAMD**

As before, but it may be associated with a gradient rather than a bearing.

**SAMG (Same gradient)**

This option allows you to select a point on an alignment feature using only PSM (only POINT PSM on elements) to extract the gradient from that point. Selection of MOSS strings is invalid in this feature.

**SAMCP (Same curve parameter)**

This feature is only valid in the selection of alignments and elements. It allows you to select a vertical alignment feature and to extract the associated 'curve parameter' value.

## Data amendment methods

The following applies to all activities except vertical design by major option ALIGNMENT (for which see Chapter 6).

POINT AMEND	BRG AMEND	DIST AMEND	NEXT NORM / LEVEL AMEND
----------------	--------------	---------------	-------------------------------------

### POINT AMEND

If you select POINT AMEND another menu is displayed:

N	S	E	W		
F	B	L	R		

- N**      **North**
- S**      **South**
- E**      **East**
- W**      **West**
- F**      **Forw'd**      Forward along the string
- B**      **Back**      Backwards along the string
- L**      **Left**      Left offset from the string
- R**      **Right**      Right offset from the string

The bottom four methods on the menu (Forward, Back, Left, Right) only apply to 6D strings.

For each choice you give the amount of movement in model units. N, S, E and W also refer to the model units, so you must be careful if the drawing displayed does not have North facing up the screen.

The details of the original point highlight will be displayed in the Status Area. As the point is moved around these details will change, and these will be shown in the scrolling menu area. The status area always contains the original point.

When you are happy that the point highlighted is in the position you require you select PROCEED to accept the point and Exit from the Amend Option. If you select QUIT at any stage of moving a point around, the point will be moved back to the last position.

The position of the point selected by the PSM may be amended at any time during its selection process.

### BEARING AMEND

This is used to amend the whole circle bearing from the value shown in the scrolling menu area to a new value. The selections are:-

- +ang**
- ang**
- +tan**
- tan**

The **ang** selections amend the bearing by the angle entered following the +/- ang. The angle is entered in the units selected for angular input style.

The **tan** selections amend the bearing by the conventional method of defining a taper (that is, the angle whose tangent is the reciprocal of the value given). So a taper of 1 in 12 would be entered as 12.

In either case the sign convention is that + adds the amendment in a clockwise direction and - anticlockwise.

Procedure is the same as for POINT AMEND.

### DISTANCE AMEND

This is used to amend the value of any distance in the scrolling menu area. The menu selections are:

+                    -                    \*                    /

You add or subtract values to distances or to multiply or divide distances by a value.

Procedure is the same as for POINT AMEND.

### LEVEL AMEND

This is used to amend the value of any level in the scrolling menu area. The menu selections are:

+                    -                    \*                    /

You add or subtract values to distances or to multiply or divide distances by a value.

### NEXT NORM

If the point was generated from NORM then NEXT NORM facility will be displayed and will give any alternative solutions.

## The LOG file

In the interests of strict quality control your organisation may wish to record all activities of your session. When MOSS is installed your organisation can choose to set the parameter file such that a complete record of your sessions will be sent to a LOG file. Unlike a journal file you have no access to this file. After each session is complete the command procedure used by your installation may choose to rename the file, so that a permanent archive may be retained.

- ◇ *Logging is controlled by the parameter file determined at the time of installation. The user has no control over it.*
- ◇ *Logging can apply to graphics mode, linemode or background mode.*

## The parameter file

The parameter file is used to store default values used by major and minor options throughout MOSS. There may be one parameter file for each system or individual users may have a parameter file in their own working directory.

To modify a default parameter in your own parameter file:

- Move to the directory containing your parameter file, 'prmdef.dat'.
- Edit the file and modify the desired parameter.
- Type the following command at the operating system prompt:

*msfile*

- In columns 1 to 8, type:

*param*

- To quit, type:

*finish*

A new binary file 'prmfil.fil' is created which is used by MOSS the next time the program is run.

## Error handling

The MOSS system recognises three types of diagnostic and deals with them in different ways, but it always displays a message in the dialogue area at the top of the interactive graphic display or on the output listing. There are three types of message, corresponding to the type of error:

- *Warning Messages*

The message starts with W and a message number, and contains either explanatory information or a warning of possible error. The system continues normally after producing a warning.

- *Error Messages*

Τη μεσσαγε τεξτ σταρτσ ωιτη Ε ανδ α μεσσαγε νυμπερ ανδ χονταινσ α δεσχριπτιον οφ τηε ερρορ. Αλλ τηε ρεμαινινγ δατα ισ συβφεχτεδ το σιμ πλε αλπηαβετιχ/νυμεριχ χηεχκσ ανδ λιστεδ. Νονε οφ τηε φολλοωινγ μα φορ ορ μινορ οπτιονσ αρε εξεχυτεδ ωιτη τηε εξχεπτιον οφ ΡΕΠΟΡΤ οπτι ονσ, ωηιχη ωιλλ προδυχε ουτπυτ ιν σπιτε οφ α πρεχεδινγ ερρορ. Ιν Ιντερ αχιτωε ΜΟΣΣ ψου χαν χορρεχτ τηε δατα ιμμεδιατελψ.

- *System Diagnostics*

The message text starts with E and error number 99. Execution of the program stops immediately. Corrective action must be taken before processing can resume. Corrective action might be to reorganise files as well as to correct possible program errors.

Most of the MOSS messages are printed to a standard format, on the same line and to the right of the input data in error whenever possible.

# General options

## Introduction

The general options enable activities such as creating, deleting and renaming models. They can be used on any model, irrespective of its type and content.

This chapter documents the following general options:

ALIAS  
ARCHIVE  
ASSIGN  
COMPRESS  
CREATE  
DELETE  
DOCUMENT  
DUMP  
ERASE  
FINISH  
FREE  
HELP  
INPUT  
JOURNAL  
LIST  
MOSS  
NEWFILE  
OUTPUT  
OVERWRITE  
RENAME  
RESTORE  
RETRIEVE  
REPLAY  
SECURE  
SUBSYSTEM

These major options have no minor options associated with them.

Several major options are available for managing the model, macro and archive files. These include an archiving facility and a facility to produce a complete sequential file copy of the model or macro file.

### Archiving facility

The archiving facility comprises four options:

ARCHIVE	Add models to the archive system.
ERASE	Delete a model from the archive file.
RETRIEVE	Retrieve models from the archive system and place them on the model file.



**LIST**                    List the contents of the archive file.

The examples given under each major option heading show only the simplest method of handling the archive master files. If archiving is to be used for long term storage of models, several copies of the files should be taken using cyclic generation datasets.

### Dump files

Two major options are provided to produce a complete sequential file copy of the macro or model file, and to restore the data.

◇ *If selected models are to be copied, major option ARCHIVE should be used.*

The major options provided are:

**DUMP**                    Produce sequential file copy of the model file  
**RESTORE**                Recreate the model file from a dump file

### File compression

Two other major options act on the model and macro files.

**COMPRESS**              Compresses the model file, macro file, or DPF.  
**NEWFILE**                Deletes the contents of the model or macro file

## Major option ALIAS

This option is only available in Linemode.

ALIAS allows you to substitute the full name of a model by a single letter or digit, usually at the beginning of a MOSS session. Thereafter MOSS automatically replaces the full name before performing the major option.

With long model names, this saves time and mistakes.

### Input

Major option ALIAS

Model 1                Name of model to be given an alias.

Model 2                Single letter to be used as alias

Both model name positions are used but the second is simply for the alias letter or digit.

### Example

```
ALIAS, THORNBROUGH INTERCHANGE, T  
EDIT, T
```

This means abbreviate the name THORNBROUGH INTERCHANGE to T. The EDIT option will then EDIT the model called THORNBROUGH INTERCHANGE.

- ◇ *Up to 20 aliases may be assigned in any one session.*
- ◇ *Any alias may be reassigned during the session.*

- ◇ *The alias is only remembered for the duration of the current MOSS session.*
- ◇ *If neither model name nor alias is typed, all the current aliases are reported.*

## Major option ARCHIVE

Major option ARCHIVE places selected models onto the archive file by copying archive models from a current file onto a new file, adding the selected models. As a result it is only permitted to execute the ARCHIVE option once in any MOSS session. A further restriction is that ARCHIVE and ERASE may not be used in the same session. It is possible to archive up to 125 models.

By default, the newly created archive file is called *archnew.fil*. You are given the opportunity to rename this file on exit from MOSS, or, for platforms other than PC-Windows, when you run MOSS in non-interactive mode as described in the example.

In PC-Windows, to change the default archive file name, replace *archnew.fil* in the [DATA] section of your project file with a file name of your choice and then run MOSS.

On completion of the major option, a list is output which indicates the models stored on the archive file, including those just archived.

If a model specified already exists on the archive file then it will be replaced.

### Input

#### Minor option 001

Fields 1-6 Model name to be archived, up to 28 characters.

### Example

To archive models in an archive file, code the following option data into the file *archsteer.inp*:

```
ARCHIVE
    THE FOLLOWING MODEL NAMES ARE TO BE ARCHIVED
001STRING GROUND MODEL
001ROAD MODEL
001INTERACTIVE MODEL
999
FINISH
```

Then, for platforms other than PC-Windows, type the following :

Then type the following :

*moss*<Return>

Do you wish to enter IGMODE, LINEMODE, UPM or Non-Interactive.

(Type I,L,U,N or FINISH to exit):

*n*<Return>

To input data direct to the program  
press RETURN otherwise  
Enter name of data file:  
*archsteer*<Return>  
Please type name for output file or  
type FINISH to exit or  
Press RETURN for *archsteer.prn*  
<Return>

To use DUMP, RESTORE, ARCHIVE, RETRIEVE or  
LIST, ARCHIVEFILE type the one you want or  
type FINISH to exit or  
press RETURN to continue  
*archive*<Return>

type in the existing archive file name or  
type FINISH to exit  
*archold.fil*<Return>  
type in the new archive file name or  
type FINISH to exit  
*archnew.fil*<Return>

For PC-Windows, input the file directly using Linemode.

## Major option ASSIGN

ASSIGN is used to direct output from either GENIO or MACRO to a specified file for storage, for later or repeated viewing, printing or copying. ASSIGN allows access to GENIO/MACRO output files without leaving MOSS. This allows access by other external packages. ASSIGN can be used as a separate major option, or from within any major option in LINEMODE.

ASSIGN is only available in LINEMODE and not in Graphics.

ASSIGN will only open the specified file if the file does not already exist. An attempt to assign an existing file will return the error 'OUTPUT FILENAME ALREADY EXISTS'. Major option OVERWRITE will allow you to open an existing file. ❏

### Input

### Graphics

Option is not available.

### Linemode

Major option ASSIGN

Model 1      Name of new output file. If blank then either the GENIO or MACRO channel will be closed depending on the second model name.

Model 2      Identifier for channel to be assigned. Input in this field is limited to GENIO or MACRO.

GENIO will be used for assigning the GENIO channel.  
MACRO will be used for assigning the MACRO channel.

- ◇ *The filename may be up to 32 characters in length.*
- ◇ *If you don't give a file extension, MOSS adds .CRD (.crd) automatically. For example, ASSIGN,new would create the file new.crd.*
- ◇ *The new output filename may also specify a full directory path. for example /newjob/repeat.dat. If a directory path is not specified the file will be written into the local directory.*

**Example**

To assign the GENIO channel to a file named NEW.DAT which does not exist

```
ASSIGN,NEW.DAT,GENIO
```

To close the GENIO channel

```
ASSIG, ,GENIO
```

**Major option COMPRESS**

COMPRESS allows you to reduce the storage space requirement for a MOSS model file, macro file or Draw Picture File (DPF).

**Model and macro files**

For the model file and macro file, it is advisable to DUMP the file prior to using COMPRESS. This ensures that if compression fails for any reason it is possible to RESTORE the file to its original condition.

A message is displayed by MOSS when the model file needs to be compressed. REPORT option 989 may be used to determine the amount of wasted space in the model file, this indicates how much space will be retrieved by COMPRESS.

**DPF**

Compressing the DPF removes wasted space from the current DPF. To remove space from another DPF, use major option NEWDPF to make the DPF current and then use COMPRESS. The amount of space retrieved varies but can be considerable in some cases, for example, when a triangulation has been erased from the DPF.

It is advisable to compress the files regularly, dependent on the contents of the file and the intensity of use.

If for any reason the DPF has become corrupt and cannot be displayed, compressing the DPF may clear the problem. This is because COMPRESS finds and removes corrupt data. An error file <DPFname>.er1 is produced which contains information about the problem.

- ◇ *Subsequent error files are named <DPFname>.er2, etc.*

**Input**

## Graphics

IGGENLT.DAT, GEN006,GEN010

Housekeeping options	COMPRESS
COMPRESS Reduce file size	Compress Modelfile
SECURE Stop inadvertent use	Compress Macrofile
FREE Remove security	
RENAME Change model name	
REPLAY Interactive replay	
DOCUMENT On-line documentation	
REPORT Models/strings/points	

◇ *Compression of the DPF is not available in graphics mode.*

## Linemode

Major option COMPRESS

Model 1 File to be compressed

MODELFILE Compress the model file

MACROFILE Compress the macro file

DPF Compress the Draw Picture File.

## Example 1

The following example puts a safe copy of the modelfile into a file named schemea.dmp and then compresses the modelfile (the dump file is not compressed).

```
moss<Return>
```

```
Do you wish to enter IGMODE, LINEMODE, UPM or Non-Interactive.
```

```
(Type I,L,U,N or FINISH to exit):
```

```
n<Return>
```

```
To input your data direct to the program
```

```
press RETURN otherwise
```

```
Enter name of data file:
```

```
<Return>
```

To use DUMP, RESTORE, ARCHIVE, RETRIEVE or LIST, ARCHIVEFILE type the one you want or type FINISH to exit or press RETURN to continue  
*dump<Return>*

type in filename for major option or FINISH to exit  
*schemea<Return>*

MOSS>*dump,modelfile<Return>*

MOSS>*compress,modelfile<Return>*

MOSS>*finish<Return>*

If required, you can restore the model file by using the RESTORE option. Macro file compression follows a sequence similar to the above.

### Example 2

An error log from a corrupt DPF is shown. Some of the point data on string D000 may have been deleted from the DPF. It is therefore advisable to redraw the string.

```
DPF Compress error log
-----
Error Action String Object Model
   2      1   D000   .... SIMPLE DESIGN GROUND

Key
---
Error  1 - Pointer to non-existent record
Error  2 - Incorrect record type found

Action 1 - data may have been deleted
Action 2 - string may have been deleted
Action 3 - Object may have been deleted
Action 4 - Model may have been deleted
```

## Major option CREATE

CREATE sets up a model name ready for the input or generation of the actual model data. This step avoids problems caused by typing errors, by giving you a chance to correct them.

### Input

### Graphics

IGGENLT.DAT, GEN003,GEN013

General Options	CREATE
CREATE	Model to be created
Empty model	
DELETE	
Remove entire model	
RENAME	
Change model name	
EDIT	
Strings and points	
COPY	
Copy/move model data	
REPORT	
Models/strings/points	

- ◇ Only one model can be created with any one CREATE.
- ◇ The model name may be up to 28 characters long.
- ◇ The model name must not exist beforehand. Hence you cannot re-CREATE; you must DELETE first.

### Linemode

Major option CREATE  
 Model 1      Name of model to be created.

### Example

CREATE, HORSHAM BYPASS  
 This means CREATE a model named 'HORSHAM BYPASS'

## Major option DELETE

DELETE removes the model from the model database. All information contained within the model will no longer exist.

If you no longer need a model it should be deleted.

### Input

#### Graphics

IGGENLT.DAT, GEN003,GEN011

General Options	DELETE
CREATE Empty model	Model to be deleted
DELETE Remove entire model	
RENAME Change model name	
EDIT Strings and points	
COPY Copy/move model data	
REPORT Models/strings/points	

- ◇ Only one model name may be deleted with any one DELETE
- ◇ If a model has been protected by applying major option SECURE you will be unable to delete it until you have removed the protection using major option FREE.

#### Linemode

Major option DELETE  
 Model 1      Name of model to be deleted.

#### Example

DELETE, HORSHAM JUNCTION  
 This means delete the model named 'HORSHAM JUNCTION'

### Major option DOCUMENT

Major option DOCUMENT provides access to the online MOSS document set.

Documents may be viewed, interrogated, marked with notes or bookmarks, and printed.

On entry to major option DOCUMENT, a document window is opened and you are presented with a list of the available documents with adjacent buttons. To select a document for viewing, double-click with the left hand mouse button on the appropriate document button.



The document window has a menu bar across the top. For full details of the facilities available in major option DOCUMENT and how to use them, select 'Help' from the menu bar.

## Input

## Graphics

IGGENLT.DAT, GEN006

Housekeeping options
COMPRESS Reduce file size
SECURE Stop inadvertent use
FREE Remove security
RENAME Change model name
REPLAY Interactive replay
DOCUMENT On-line documentation
REPORT Models/strings/points

## Linemode

Major option DOCUMENT

No field data is required.

- ◇ *Major option DOCUMENT is also available as a standalone program, MSDOCUMENT.*

## Major option DUMP

Major option DUMP produces a complete sequential file copy of the macro or model file. The main use of this option is to create backups or safe copies of the files.

DUMP and RESTORE may not be necessary if you take regular backup copies of complete disks. If DUMP and RESTORE are to be used it may be advisable to investigate the use of cyclic generation datasets for the backup files.

By default, the newly created dump file is called *dump.dmp*. You are given the opportunity to rename this file on exit from MOSS, or, for platforms other than PC-Windows, when you run MOSS in non-interactive mode as described in the example.

In PC-Windows, to change the default dump file name, replace *dump.dmp*

in the [DATA] section of your project file with a file name of your choice and then run MOSS.

Within a single session of MOSS, you may run either major option DUMP or RESTORE only once.

### Linemode

Major option DUMP

Model 1 File to be dumped

MODELFILE Dumps the model file

MACROFILE Dumps the macro file

◇ *The model or macro file data is dumped in the file dump.dmp. You are given the opportunity to rename this file on exit from MOSS if you desire.*

### Example

This session puts a dump of a model file into file schemea.dmp by running MOSS in non-interactive mode.

For platforms other than PC-Windows, type the following :

*moss*<Return>

Do you wish to enter IGMODE, LINEMODE, UPM or Non-Interactive.

(Type I,L,U,N or FINISH to exit):

*n*<Return>

To input your data direct to the program press Return otherwise

Enter name of data file:

<Return>

To use DUMP, RESTORE, ARCHIVE, RETRIEVE or LIST,ARCHIVEFILE type the one you want or type FINISH to exit or press RETURN to continue

*dump*<Return>

type in filename for major option or

FINISH to exit

*schemea*<Return>

MOSS>*dump,modelfile*<Return>

MOSS>*finish*<Return>

For PC-Windows, input the commands directly using Linemode.

## Major option ERASE

Major option ERASE removes models from the archive file by copying the current archive file onto a new file, ignoring those models to be erased.

ERASE may only be used once in any MOSS session and may not be used in the same run as ARCHIVE. Up to 125 models may be erased from the archive file at any one time.

If a model to be erased from the archive file still exists in the model file, the ERASE option is ignored, and the model must be deleted using major option DELETE before it may be erased from the archive file.

On completion of this major option, a list of those models currently stored on the archive file is produced.

### Input

#### Minor option 001

Fields 1-6 Name of model to be erased, up to 28 characters

### Example

To erase models from an archive file, type the following option data into the file `erasteer.inp`:

```
ERASE
    THE FOLLOWING MODEL NAMES ARE DELETED FROM THE
ARCHIVE FILE
001STRING GROUND MODEL
001ROAD MODEL
001INTERACTIVE MODEL
999
FINISH
```

Then type the following:

*moss*<Return>

Do you wish to enter IGMODE, LINEMODE, UPM or Non-Interactive.

(Type I,L,U,N or FINISH to exit):

*n*<Return>

To input your data direct to the program

press RETURN otherwise

Enter name of data file:

*erasteer*<Return>

Please type name for output file or

type FINISH to exit or

Press RETURN for `erasteer.prn`

<Return>

To use DUMP, RESTORE, ARCHIVE, RETRIEVE or

LIST,ARCHIVEFILE type the one you want or

type FINISH to exit or

press RETURN to continue

*archive*<Return>

type in the existing archive file name or

type FINISH to exit

*archold.fil*<Return>

type in the new archive file name or

type FINISH to exit

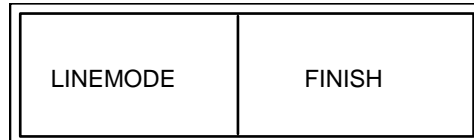
*archnew.fil*<Return>

## Major option FINISH

FINISH indicates the end of the input data to a MOSS session.  
FINISH should be entered when no further input data is to be processed.

### Input

#### Graphics



Select FINISH from the Dynamic Menu area of the IGMODE display.

- ◇ *Finish will prompt “A draw file exists do you wish to delete it?” (Type Y or N)*
- ◇ *If the answer to 1st prompt is NO the prompt will be “Do you wish to rename the file?” (Type Y or N)*

#### Linemode

Major option FINISH

No models are required. There is no associated data.

#### Example

```
FINISH
```

This means ‘end the current MOSS session’.

- ◇ *FINISH records included in an INPUT file are ignored.*

## Major option FREE

FREE removes ‘read only’ security from a model, allowing amendments to be made to the model.

FREE is complementary to SECURE.

### Input

### Graphics

IGGENLT.DAT, GEN006,GEN012

Housekeeping options	FREE
COMPRESS Reduce file size	Model to Free
SECURE Stop inadvertent use	
FREE Remove security	
RENAME Change model name	
REPLAY Interactive replay	
DOCUMENT On-line documentation	
REPORT Models/strings/points	

- ◇ *When models are first created they are automatically in read/write status to allow data to be stored.*
- ◇ *FREE is only used on a model if that model has been previously made SECURE.*

### Linemode

Major option FREE

Model 1      Name of model to be freed for amendment.

### Example

FREE, HORSHAM JUNCTION

## Major option HELP

Major option HELP provides in-context access to the MOSS document collection. It is a quick and easy method of opening the documentation at the page appropriate to the subject you specify.

Once open documents may be viewed, interrogated, marked with notes or bookmarks, and printed.

The document window has a menu bar across the top. For full details of the facilities available and how to use them, select 'Help' from the menu bar.

## Input

### Graphics

To access major option HELP select 'Help' from the static menu area. You will be prompted to select the box or area of the screen for which you require help. For example, a second selection on the 'Help' box will open the Help on Help document page.

Once the help requested is displayed, the operation and navigation within the document is identical to that in major option DOCUMENT.

The information provided by both major options HELP and DOCUMENT is identical.

- ◇ *When you are using a UPM which has a UPM HELP button you will find that it reacts in the same way as the 'Help' button. For example a second selection is necessary to specify the help you require.*

### Linemode

- ◇ *Major option HELP is not available in Linemode.*

## Major option INPUT

You use INPUT to run a prepared file of major and minor options.

It is useful when you have a sequence of MOSS commands that you need to run frequently; and if you have several such sequences from which you create several input files it saves coming out of MOSS and going back each time to run each new file.

INPUT removes keyboard control from you, processes the file, and returns keyboard control to you upon completion. This is the basic action, and in linemode that is all there is but in graphics mode INPUT does two things before running the file: first it checks whether the file exists in the local directory and if it doesn't exist it lets you create it; and second it asks you whether you want to edit it before running it.

In either mode, if INPUT encounters an error while processing the input file, it will normally terminate but you can specify that processing is to continue from the next MOSS record following the error by adding the qualifier CONT to the command input.

## Input

### Graphics

INPUT	OUTPUT	JOURNAL	ALPHA
			BROWSE

You are prompted for the name of the input file.  
Type (for example *ABCD*), and:

If you want processing to continue after encountering an error:  
Add ,CONT (for example ABCD,CONT).

If you want to positively specify that processing is to stop at an error:  
Add ,STOP (for example ABCD,STOP).

However, this is no different from the default action you get if you simply type the filename.

You are asked whether you want to edit the file or, if it does not exist, whether you want to create it: To edit or create the file:

Type Y; otherwise type N.

To process the file, select PROCEED.

## Linemode

Major option INPUT

Model 1 Name of file to be input

Model 2 Error indicator:

CONT Continue processing after an error

STOP Stop processing after an error (default)

- ◇ *INPUT can be invoked in graphics mode, linemode or background mode.  
(In background mode it allows you to keep input files short and run the combination of files you need all in one MOSS run).*
- ◇ *If an input file doesn't exist you create one using the system editor, giving it a filename of up to 64 characters.*
- ◇ *If you enter just the filename after INPUT, you must be sure that the file is in the local directory; if not, you must give the full pathname.*
- ◇ *If you don't give the filename a suffix, INPUT assumes .INP This means that it finds ABCD.INP but would not find a file just called ABCD. It does not append the suffix .INP to files.*
- ◇ *Before processing the input file MOSS scans it to detect invalid requests. If it finds one it stops and generates an error message.*

*For instance, you cannot invoke MOSS while you are already running it; and if you are running INPUT from graphics mode you cannot generate a new drawing (though you can add to an existing drawing).*

## Example

A previously prepared data set called ABCD.INP may contain the following commands:

```
MOSS
REPORT, SIMPLE DESIGN GROUND
991
999
```

To process this while in LINEMODE, type:

```
INPUT, ABCD
```

## Major option JOURNAL

Whilst OUTPUT records everything that would appear on an output listing, it is sometimes important to segregate the input from the output. Various alternatives are available.

One method is to record all input into a journal file. The journal file will contain all input commands, expanded macro data, and expanded input file details. This file is primarily a means of recording all input data transactions within a MOSS session.

JOURNAL may be accessed from linemode, subsystem or background mode.

### Input

### Graphics

INPUT	OUTPUT	JOURNAL	ALPHA
			BROWSE

When you select JOURNAL you may turn on the journal process by typing a filename, or turn off the journal by hitting return (eg not typing a filename).

If you type a new filename without cancelling the old file name, the old file will be closed and the new file opened.

### Linemode

#### Major option JOURNAL

Model 1 Name of journal file to record data

If left blank, the file is closed.

If a journal file is already open, it is closed and the specified file opened.

- ◇ *You may begin and end recording whenever you choose.*
- ◇ *Each request to JOURNAL terminates the previous request*
- ◇ *The information stored on a journal file will contain all input commands. If you use INPUT while JOURNAL is in force you will find the INPUT command line is recorded as a comment. Similarly if you invoke a macro option, the macro line will be recorded as a comment.*
- ◇ *You must exercise care if you are to use the journal file to rerun some data. The journal file should only be applied to a model file which has not been updated.*

### Example

The following command will open a file called XYZ.JOU:

```
JOURNAL, XYZ
```

The following command sequence records the first block of data A into ABCD.JOU and then the next block of data B into XYZ.JOU, but the block of



data C is not recorded at all because no file name is given on the last JOURNAL.

```
JOURNAL, ABCD
    'block of data A'
.
.
JOURNAL, XYZ
    'block of DATA B'
.
.
.
JOURNAL
    'block of data C'
```

## Major option LIST

This option lists the names of all models held on the current archive file.

### Input

Major option LIST  
Model 1      File to be listed  
                 ARCHIVEFILE List the archive file  
There is no minor option data for this option.

### Example

To list the models in an archive file:

```
moss<Return>
Do you wish to enter IGMODE, LINEMODE, UPM or Non-
Interactive.
(Type I,L,U,N or FINISH to exit):
n<Return>

To input data direct to the program
press RETURN otherwise
Enter name of data file: <Return>

To use DUMP, RESTORE, ARCHIVE, RETRIEVE or
LIST, ARCHIVEFILE type the one you want or
type FINISH to exit or
press RETURN to continue
list,archivefile<Return>

type in the existing archive file name or
type FINISH to exit
archnew.fil<Return>
MOSS>list,archivefile<Return>
MOSS>finish
```

## Major option MOSS

At the beginning of a MOSS session you may use major option MOSS to define the title of the job. This title is then printed at the top of each page of output. You can use MOSS subsequently within the session to change the title, and to separate a large job into several smaller ones.

MOSS is a single line option with no associated minor option.

### Input

#### Graphics

No menus exist to invoke major option MOSS in graphics. All error indicators are reset wherever you change between graphics selected major options.

The output job titles may be easily changed by temporary exit to Linemode as shown below.

◇ *The job title will be retained until you FINISH with MOSS.*

#### Linemode

Major option MOSS

Model 1 & 2 Job title

No models are required but the text given in the model name position will be echoed at the top of each page of output, as the job title.

### Example

```
MOSS,DESIGN OF THORNBROUGH INTERCHANGE
```

This means print the heading 'DESIGN OF THORNBROUGH INTERCHANGE' at the top of each page of output.

- ◇ *Major option MOSS forces any error indicators to be reset as if at the start of a job. This ensures, if running a data file, that the set of data following a MOSS option will be processed even though an error may have occurred previously. This rule is particularly useful where several unrelated operations are to be processed in the same session.*
- ◇ *If an option fails because of an obvious mistake in inputting data (such as field omitted, or surplus data) the system will ask you to re-input. If an option fails because the data supplied is consistent with the option but produces an arithmetic error, then you must use the MOSS option to reset error flags before you can proceed.*

## Major option NEWFILE

NEWFILE deletes the contents of a file and should therefore be used with some caution.

MOSS files are initialised using MSFILE and therefore the NEWFILE facility is not generally required. It may be required in certain circumstances when using major option RESTORE.

## Input

### Linemode

Major option NEWFILE

Model 1 File to be erased

MODELFILE Deletes contents of the model file

MACROFILE Deletes contents of the macro file

## Major option OUTPUT

OUTPUT is used to direct output from MOSS to a specified file for storage, for later or repeated viewing, printing or copying. OUTPUT can be used as a separate major option, or from within any major option in LINEMODE.

In a sense OUTPUT is complementary to INPUT: in using INPUT you specify the file that the input is coming from, and in using OUTPUT you specify the file that the output is to go to.

Directing the output to a file exclusively is the default action.

You can also specify:

- to direct it to the screen simultaneously, if you wish
- to re-direct it to the screen exclusively

Warning and error messages, along with the line of data to which they refer, will appear at the screen even when output is directed exclusively to a file.

## Input

### Graphics

INPUT	OUTPUT	JOURNAL	ALPHA
			BROWSE

The input dialogue for OUTPUT is:

You are prompted for the name of the file to which your output will go.

Type the filename (for example, 'abcd') and, optionally, any one of the following qualifiers preceded by a comma:

TERM Direct output to file and to screen.

NOTERM Direct output to file only (default).

In both of the above cases, if you specify a new output file when one is already open, the old file is closed and the new one is opened. To append output to an existing file, use either of the following qualifiers:

APTE Append output to existing file and direct to screen.

APPE        Append output to existing file only.  
To revert output to the screen only, re-submit OUTPUT without a filename.

### Linemode

Major option OUTPUT

Model 1     Name of output file to record data.

If left blank, any output file already open is closed and output reverts to the screen.

Model 2     Output direction.

TERM        Direct output to screen and to file

NOTERM     Direct output to file only (default)

In both of the above cases, if you specify a new output file when one is already open, the old file is closed and the new one is opened.

APTE        Append output to existing file and direct to screen

APPE        Append output to existing file only

- ◇ *The filename may be up to 26 characters in length.*
- ◇ *Output of the MOSS banner can be enabled or disabled by setting the BANNEROP flag in the parameter file.*
- ◇ *If you don't give a file extension, MOSS adds .PRN automatically. For example, OUTPUT,XYZ would direct output to the file XYZ.PRN*

### Example

A previously created data set called ABCD may contain the following commands:

```
MOSS
REPORT, SIMPLE DESIGN GROUND
991
999
```

To process this while in LINEMODE, type:

```
MOSS > OUTPUT, XYZ
MOSS > INPUT, ABCD
```

The results of running the file ABCD.INP would be stored within the file XYZ.PRN

## Major option OVERWRITE

OVERWRITE is used to direct output from either GENIO or MACRO to a specified file for storage, for later or repeated viewing, printing or copying. OVERWRITE allows access to GENIO or MACRO files without leaving MOSS. This allows access by external software packages. OVERWRITE can be used as a separate major option, or from within any major option in LINEMODE.

This option will overwrite the existing file content.

OVERWRITE is only available in LINEMODE and not in Graphics.

OVERWRITE will open the specified file whether or not the file already exists. The associated major option ASSIGN will not allow you to open an existing file but returns an error. ❌

## Input

### Graphics

Option is not available.

### Linemode

Major option OVERWRITE

Model 1 Name of new output file. If blank then either the GENIO or MACRO channel will be closed depending on the second model name.

Model 2 Identifier for channel to be assigned. Input in this field is limited to GENIO or MACRO.

GENIO will be used for assigning the GENIO channel.

MACRO will be used for assigning the MACRO channel.

- ◇ *The filename may be up to 32 characters in length.*
- ◇ *If you don't give a file extension, MOSS adds .CRD (.crd) automatically. For example, OVER,repeat would create the file repeat.crd.*
- ◇ *The new output filename may also specify a full directory path for example /newjob/repeat.dat. If a directory path is not specified the file will be written into the local directory.*

## Example

To assign the GENIO channel to a file named REPEAT.DAT which already exists

```
OVER, REPEAT.DAT, GENIO
```

To close the GENIO channel

```
OVER, , GENIO
```

## Major option RENAME

Renames any model at any stage.

RENAME enables you to achieve consistency across your scheme by rationalising the names you have used.

### Input

### Graphics

IGGENLT.DAT, GEN003,GEN009

General Options	RENAME
CREATE	
Empty model	Existing model
DELETE	New model
Remove entire model	
RENAME	
Change model name	
EDIT	
Strings and points	
COPY	
Copy/move model data	
REPORT	
Models/strings/points	

◇ *Once renamed a model can only be accessed by its new name. The old name is deleted.*

### Linemode

Major option RENAME

Model 1 Existing name of model (maximum 32 characters)

Model 2 New name of model (maximum 28 characters).

### Example

```
RENAME, DESIGN MODEL, THORNBROUGH ROAD DESIGN
```

This means, change the name of the model called 'DESIGN MODEL' to 'THORNBROUGH ROAD DESIGN'.

## Major option REPLAY

REPLAY allows you to repeat all or part of a previous MOSS session, and is used to build up demonstrations, reproduce problems and trace errors.

Two files are required by REPLAY; 'archmod.fil' and 'mossv##igm.log' (## is the current MOSS version). The file archmod.fil contains a copy of each model (as it was at the beginning of the session) subsequently modified during the session. The file mossv##igm.log contains a recording of all IGMODE selections in the session.

Before using REPLAY both the model file and the dpf must be in the same state as they were at the beginning of the previous session. Use Major option RETRIEVE to restore the models from archmod.fil to the model file.

- ◇ *Within any one MOSS session, a particular model is saved only once.*
- ◇ *Options run in Linemode are not logged in the REPLAY file.*

## Log control

There are two settings to control REPLAY within the Graphical environment settings. (see below)

Logging is controlled by the IGMODE log switch (LGIGSWCH) in the parameter file *prmdef.dat*. This switch has three settings :-

- 0 IG logging and model saving OFF.
- 1 IG logging and model saving ON.
- 2 IG logging ON, model saving OFF. (default setting)

## Input

### Graphics

IGGENLT.DAT, GEN006

Housekeeping options
COMPRESS
Reduce file size
SECURE
Stop inadvertent use
FREE
Remove security
RENAME
Change model name
REPLAY
Interactive replay
DOCUMENT
On-line documentation
REPORT
Models/strings/points

## Linemode

To replay script and tutorial files:

Major option REPLAY

Model 1 Name of log file to be replayed

- ◇ *The model file base must be the same one as before the REPLAY file was created.*
- ◇ *On entering a second MOSS session *mossv###igm.log* is renamed to *mossv###igm.sav*.*
- ◇ *On entering a third MOSS session *mossv###igm.log* is overwritten.*

- ◇ *The default file extension for REPLAY is .rep*
- ◇ *Replay files are not supported between MOSS versions*
- ◇ *There are two switches within the environment settings in IG to control the use of REPLAY:*

*REPLAY pause switch: requires confirmation of picks: Pauses can be placed into the log file by picking the MOSS banner in the top right corner of the IG screen.*

*REPLAY locator switch: controls the position of each pick within the IG session.*

### Example

An example REPLAY to correct an accidental file deletion might be:

#### **Initial MOSS session**

- Enter MOSS
- Input DRAW data from a file using SURVDRAW to draw up model 'SURVEY GROUND MODEL'
- MOSS>IG
- Make several EDIT's to tidy up the survey ('SURVEY GROUND MODEL' is archived on entry to major option EDIT)
- Use TRIANGLE to triangulate the surface (new model 'SURVEY TRIANGLES' is automatically created).
- Use SURFACE to create the contours (new model 'SURVEY CONTOURS' is automatically created).
- Use IG DELETE to tidy up modelfile but accidentally delete the 'SURVEY GROUND MODEL' (model not rearchived here).

#### **To REPLAY the initial MOSS session**

- At operating system level, rename MOSSV9IGM.LOG to EXAMPLE.REP and ARCHMOD.FIL to ARCHOLD.FIL
- Enter MOSS at LINEMODE
- MOSS>DELETE,SURVEY TRIANGLES
- MOSS>DELETE,SURVEY CONTOURS
- MOSS>RETRIEVE
- RETR>001,SURVEY GROUND MODEL
- RETR>999  
(modelfile is now the same)  
Re-INPUT drawing data from file (dpf is now the same)
- MOSS>IG  
Set 'Envir REPLAY pause switch' to be 'PAUSE after every pick'  
Select Housekeeping Options REPLAY type 'EXAMPLE'.



Select 'PROCEED' through every prompt until the erroneous 'DELETE' selection then 'QUIT'.

## Major option RESTORE

Major option RESTORE reads a dump file and recreates the macro or model file from the dump file data.

The model or macro file data is restored from the file *dump.dmp*. If your dump file is not called *dump.dmp*, you can either rename the file to *dump.dmp* before using RESTORE, or, for platforms other than PC-Windows, run MOSS in non-interactive mode as described in the example. In PC-Windows, you can replace *dump.dmp* in the [DATA] section of your project file with your dump file name before entering MOSS.

### Input

#### Linemode

Major option RESTORE

Model 1 File to be restored.

MODELFILE Restores the model file

MACROFILE Restores the macro file

The model or macro file data is restored from the file *dump.dmp*. If your dump file is not called *dump.dmp*, you can either rename the file to *dump.dmp* before using RESTORE, or run MOSS in non-interactive mode as described in the example. In PC-Windows, you can also replace *dump.dmp* in the [DATA] section of your project file with your dump file name before entering MOSS.

### Example

To restore a dump file (not PC-Windows):

```
moss<Return>
```

```
Do you wish to enter IGMODE, LINEMODE, UPM or Non-Interactive.
```

```
(Type I,L,U,N or FINISH to exit):
```

```
n<Return>
```

```
To input your data direct to the program
```

```
press RETURN otherwise
```

```
Enter name of data file:
```

```
<Return>
```

```
To use DUMP, RESTORE, ARCHIVE, RETRIEVE or
```

```
LIST,ARCHIVEFILE type the one you want or
```

```
type FINISH to exit or
```

```
press RETURN to continue
```

```
restore<Return>
```

```
type in filename for major option or
```

```
FINISH to exit
```

```

schemea<Return>
MOSS>restore,modelfile<Return>
MOSS>finish<Return>

```

This job restores a model file from the file *schemea.dmp*  
For PC-Windows, input the commands directly using Linemode.

## Major option RETRIEVE

This option retrieves models from the archive file and appends them to the model file. Up to 125 models may be retrieved in one MOSS session.

The archive data is retrieved from the file *archold.fil*. If your archive file is not called *archold.fil*, you can either rename the file to *archold.fil* before using RETRIEVE, or, for platforms other than PC-Windows, run MOSS in non-interactive mode as described in the example. In PC-Windows, you can replace *archold.fil* in the [DATA] section of your project file with your archive file name before entering MOSS.

If the model already exists on the model file, then the retrieve request will be rejected for that model.

RETRIEVE may be used in the same job as ERASE or ARCHIVE, provided RETRIEVE occurs first.

### Input

```

Minor option 001
Model 1      Model name to be retrieved, up to 32 characters.
Model 2      New model name to be used, if different from old. Up to 28
              characters may be specified.

```

### Example

To retrieve models from an archive file, code the following option data into file *retrsteer.inp*:

```

RETRIEVE
    THE FOLLOWING MODELS ARE RETRIEVED
001STRING GROUND MODEL
001ROAD MODEL
001INTERACTIVE MODEL
999
FINISH

```

Then, for platforms other than PC-Windows, type the following :

Then code the following:

```

moss<Return>
Do you wish to enter IGMODE, LINEMODE, UPM or Non-
Interactive.
(Type I,L,U,N or FINISH to exit):
n<Return>

```

To input data direct to the program  
 press RETURN otherwise  
 Enter name of data file:  
 retrsteer<Return>

Please type name for output file or  
 type FINISH to exit or  
 Press RETURN for retrsteer.prn  
 <Return>

To use DUMP, RESTORE, ARCHIVE, RETRIEVE or  
 LIST, ARCHIVEFILE type the one you want or  
 type FINISH to exit or  
 press RETURN to continue  
 retrieve<Return>

type in the existing archive file name or  
 type FINISH to exit  
 archnew.fil<Return>

For PC-Windows, input the file directly using Linemode.

## Major option SECURE

Gives a model read-only status, to protect against accidental or unauthorised changes.

### Input

### Graphics

IGGENLT.DAT, GEN006,GEN008

Housekeeping options	SECURE
COMPRESS Reduce file size	Model to be secured
SECURE Stop inadvertent use	
FREE Remove security	
RENAME Change model name	
REPLAY Interactive replay	
DOCUMENT On-line documentation	
REPORT Models/strings/points	

◇ To regain write status for the model use major option FREE.

## Linemode

Major option **SECURE**  
Model 1      Name of model to be protected

## Example

**SECURE, THORNBROUGH GROUND MODEL**

## SUBSYSTEM

Mistakes and incorrect assumptions inevitably occur in preparing data sets. It can be frustrating and time-consuming to exit from MOSS, correct the data set, and then resubmit the data. **SUBSYSTEM** suspends the current processing and gives you access from within MOSS to some of the more common system functions, in order to amend data or create a new data set that may then be immediately processed.

**SUBSYSTEM** is invoked from within linemode.

It is possible to use **SUBSYSTEM** in background mode, but it is not common practice. Once **SUBSYSTEM** is invoked you can either use the system Editor or you can process a data file.

Ancillary functions available within **SUBSYSTEM** are :

**SYSDEL**      (data file)  
**SYSEDT**      (a data file)  
**SYSLIS**      (a directory)  
**SYSPRINT**   (a file)  
**SYSRENAME**              (a file)  
**SYSTYPE**      (a file)  
**SYSCOPY**      (a file)

Also :

**INPUT**      (a data file into MOSS)  
**OUTPUT**      (results from MOSS)  
**JOURNAL**      (the input commands)  
**DISPLAY**      (a drawing on your graphics screen)  
**SUBPLOT**      (direct a drawing to the PLOTTER).

On selecting each function you specify any file names associated with the command. On completing the function, you are returned to the mode from which you called **SUBSYSTEM**.

- ◇ *To return from **SUBSYSTEM** to major option level when in linemode, enter 999*
- ◇ *With workstations that provide multiple windows you won't need to use **SUBSYSTEM**.*
- ◇ *To return to graphics from **SUBSYSTEM** type 999 to return to major option level in Linemode. Then type IG to return to graphics.*

## Global minor options

Throughout MOSS each major option has an associated series of minor options. Usually the minor options are unique to that major option. However there are some minor options which are generally available throughout the system. These are the global minor options. They are used to define vital parameters which affect the method of computation to be used.

The global minor options are:

000	Add log comments
001	Provide supplementary information
003	Define the order of items
017	Define system parameters
018	Define linear units
019	Define selection mask
900	Invoke a macro option
999	End a major option.

Minor options 000 and 001 do not have the standard minor option layout.

### Minor option 000    Add log comments

Inserts a comment line in the input data.

Use it to include text within your input data that describes the tasks being carried out, to help document the progress of a particular design.

**Input**

## Graphics

Add log comments
Text to be logged

- ◇ *If you select minor option 000 from the scrolling menu area and type in your chosen text, then the comment will be echoed into any output or logging file being generated.*

## Linemode

Minor option 000 (or blank)

Fields 1-10 Alphanumeric text

## Example

```
000, THIS IS A COMMENT
```

- ◇ *Comment lines may not be used within major options HCUSP and VCUSP.*
- ◇ *Comment lines may appear outside major options.*

**Minor option 001 Provide supplementary information**

Option 001 has two uses:

- To specify text, as in options 002, 847, etc
- To specify Fortran FORMAT statements in order to alter input and output, as in options 080, 081, etc.

It has no specific use on its own and is always used in conjunction with another major and minor option combination.

For details, refer to the description of the minor option with which 001 is being used.

Options which use minor option 001 include:

<b>Major Option</b>	<b>Minor Option</b>
DRAW	847, 854, 858, 859
3DDXF	451, 453
EDIT	002
GENIO	080, 081
REPORT	985, 993
VOLUME	051

## **Minor option 003    Define the order of items**

Defines the order in which the items within a string point are input or output.

It has no specific use on its own and is always used in conjunction with another major and minor option combination.

For details, refer to the description of the minor option with which 003 is being used.

Options which use minor option 003 include:

<b>Major Option</b>	<b>Minor Option</b>
GENIO	080, 081
REPORT	993

## **Minor option 017    Define system parameters**

Throughout MOSS various values are used to determine the method of calculation to be used, and under certain circumstances it may be necessary to change one or more of these values. Option 017 can be used to do this at any point in the processing. Values changed retain their new value either until they are changed again or until the end of the current MOSS session.

### **Input**

#### **Graphics**

In graphics, you first select minor option 017 from the scrolling menu area, then the system parameter to be changed.

**IGDEIT.DAT, DES050**

Define system parameters	Define system parameters
Curve fitting status (T)	Survey station str label
Input coord notation (T)	Secondary interp tolerance
Angular input units (T)	Point search tolerance
English/French design (T)	Left section offset tol
Triangle error echo (T)	Section baseline bearing
Triangle FLAT/NOFL (T)	Secondary interp offset
Vertical/normal offsets (T)	Right section offset tol.
French road type (T)	
Output coord notation (T)	
Angular output units (T)	

- ◇ *Not all system parameters are available each time the menu is displayed. Major options such as COPY and AREA, show only those system parameters relevant to the major option.*

The following text describes each of the menu items. The field number allocations for data follow after that.

**Curve fitting**

The curve fitting status is on a toggle (T) between CURV (curve fitting) and NOCU (no curve fitting).

In calculating intersections between strings, and in other geometric analyses, you can select whether the strings should be treated as curvilinear or polygonal. If the strings represent curved features then curve fitting will ensure any interpolated points are accurate. However if the strings represent polygonal features such as fences or property boundaries then the intersections should be calculated by straight line interpolation.

**Input coord notation**

The input coordinate notation is a toggle between:

XY	UK coordinates
YX	US coordinates
DANE	Danish coordinates
CZ01	Czech coordinates, first convention
CZ02	Czech coordinates, second convention

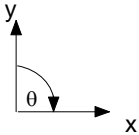
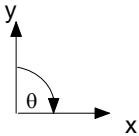
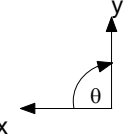
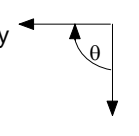
- ◇ *If DANE, CZ01, CZ02 are selected, then they must be selected for both input and output .*



**Output coord notation**

Output coordinate notation operates in a similar fashion to input coordinate notation, although, in some cases, you may select a different notation for each. See 'Input coordinate notation' for further details.

The different coordinate systems are shown in Figure 2 - 15.

System	Stored as	Input	Output	Parameter
XY		(x, y)	(x, y)	YXORD_IN = 0 YXORDOUT = 0
YX		(x, y)	(y, x)	YXORD_IN = 1 YXORDOUT = 1
DANE		(y, x)	(y, x)	YXORD_IN = 0 YXORDOUT = 2
CZ01		(y, x)	(x, y)	YXORD_IN = 1 YXORDOUT = 3

**Figure 2 - 15 Standard coordinate systems**

Your MOSS parameter file will be set up to accept your standard practice but you may temporarily change the convention during a session.

**Angular input units**

Angular input is on a toggle between:

- DMS            Sexagesimal notation; degrees, minutes and seconds
- DEGR         Centesimal; degrees and decimal degrees
- GRAD         Grads
- RADI         Radians
- QUAD         Quadrant bearings
- NORM         Mixture of sexagesimal and centesimal notation, depending on the option currently in use.

For example, you should input an angle of 56 degrees, 44 minutes and 44.3 seconds for each type of unit as follows:

DMS	564444.3
DEGR	56.7456366 (or 56.746 as only three decimal places are used)
GRAD	63.0507074
RADI	0.9903982
NORM	564444.3
QUAD	1564444.3

Your usual convention will be set up when your system is installed, but you can change the style during the run. It is possible to input information using one angular unit and report it in another unit.

In quadrant bearings, the first digit of the defined angle defines the quadrant and the remaining digits the direction. For example, 1421632 would be interpreted as N42 16 32E whilst 4421632 would be interpreted as N42 16 32W. Note that the angle is always measured from the North-South axis.

#### English / French design

This is a toggle between EDES/FDES, and invokes the appropriate design rules.

#### Triangle error echo

This is a toggle which allows you to output the coordinates of each point in a model as it is being added to a triangulation.

#### Triangle FLAT/NOFL

This is a toggle which indicates whether flat triangles (ie, triangles having the same level at each vertex) are to be included in a triangulation.

#### Vertical/normal offsets

This is a toggle which determines whether offsets are measured vertically or normal to a string in major option DESIGN.

Further details may be found in Chapter 8.

#### French road type

The French road type allows you to select the following road types:

AR	Autoroute (motorway)
RP	Route principale (major road)
UR	Route urbaine (urban road)
AR	Motorway
RN	National route
UR	Urban route

#### Angular output units

The angular output is on a toggle between:  
DMS, DEGR, GRAD, RADI, QUAD, NORM.

You can choose the output angular notation to differ from the input angular notation. The same rules as described for angular input apply.

For example, an angle of 56 degrees, 44 minutes and 44.3 seconds for each type of unit is output as follows:

DMS	56 44 44.3
DEGR	56.7456366
GRAD	63.0507074
RADI	0.9903982
NORM	56 44 44.3
QUAD	N56 44 44.3E

### Survey station string label

Survey station strings are given the label PSSA by default and all survey stations are automatically included in this string. You may choose a string name other than PSSA. You are advised to retain the convention PSS for the first three characters.

You will be prompted to type in the revised label name. To do this, first select Keyboard from the menu, then type.

Further details of the survey station string are in Chapter 5.

### Secondary interp tolerance

If the interpolation density of string information is insufficient, sections may be inadequately derived. It is possible to invoke a secondary interpolation process to enhance the section data. The secondary interpolation tolerance determines the frequency of the secondary interpolated points. Chapter 9 describes the secondary interpolation process more fully.

### Point search tolerance

Two points are considered equal if they are within a specific distance of one another. This distance is known as the point search tolerance. The default is 0.010 model units and this value should be changed only with caution.

You will be prompted to type in the revised value for the point search tolerance.

### Left section offset tolerance

This offset restricts the distance that options will search normal to the left hand side of the reference string. This applies to major options which create automatic section eg INTERFACE, VOLUME and DESIGN.

For the left side, you will be prompted to type into the Keyboard window the (new) value for the left section offset. Remember that the default value is -100.00 and the sign is important.

Refer to Chapter 8 and 9 for further details.

### Section baseline bearing

The automatic extraction of parallel sections for the calculation of volumes is carried out normal to a baseline, and the bearing of this baseline may be varied. The default bearing for the baseline is parallel to the Y axis.

You will be prompted to type in the revised value. Remember to use the current style of inputting angular information.

### The secondary interpolation offset

This is used in conjunction with the secondary interpolation tolerance. You will be prompted to type in the revised value. The default is the same as the secondary interpolation tolerance. A fuller description is given in Chapter 9.

### Right section offset tolerance

This value is the rightside equivalent to the left section offset described above. You will be prompted to type in the revised value.

### Linemode

#### Minor option 017

Field 1      First system parameter

Curve fitting status:

CURV      switch on curve fitting (default)

NOCU      switch off curve fitting

Input coordinate notation:

XY          coordinates input as (X,Y)

YX          coordinates input as (Y,X)

DANE      Danish convention (for both input and output)

CZ01      Czech coordinates, first convention (for both input and output)

CZ02      Czech coordinates, second convention (for both input and output)

English/French design:

EDES      English design

FDES      French design

Triangle error echo:

ECHO      output coordinates of points added to a triangulation.

NOEC      cancels ECHO code.

Triangle FLAT/NOFL:

FLAT      allows flat triangles.

NOFL      cancels FLAT code.

Vertical/normal offsets:

VOFF      use vertical offsets

NOFF      use normal offsets

Angular input:

DMS      Degrees minutes and seconds - sexagesimal

DEGR      Degrees and decimal degrees - centesimal

GRAD      Grads

	RADI	Radians
	NORM	Mixture of sexagesimal and centesimal
	QUAD	Quadrant bearings.
Field 2		Second system parameter
		French road type:
	AR	Autoroute (motorway)
	AR	Motorway
	RP	Route principale (major road)
	UR	Route urbaine (urban road)
	RN	National route
	UR	RUrban route
		Output coordinate notation: XY, YX, DANE, CZ01, CZ02. See input coordinate for details.
		Angular output: DMS, DEGR, GRAD, RADI, NORM, QUAD as above.
Field 3		Survey station string label default PSSA
Field 4		Secondary interpolation tolerance: Supply 0.0 to switch off secondary interpolation. Default is 20.0 model units.
Field 5		Point search tolerance: Default is 0.01
Field 7		Maximum section offset to left of reference string: Default is -100.0 model units.
Field 8		Bearing of baseline for automatic sections: If NORM is the angular input give the value in centesimal
Field 9		Secondary interpolation offset: Default is the secondary interpolation tolerance
Field 10		Maximum section offset to right of reference string: Default is 100.0 model units.

Example

```
017, CURV,
017, DMS, QUAD
017, XY, XY, 7=-50.0, 10=+150
```

This means: apply curve fitting, accept angular data input in the form of degrees minutes and seconds, and output angular data in the form of quadrant bearings. Coordinate notation for both input and output is (X,Y). Then in extracting sections, search for information to a maximum of 50 to the left hand side and 150 to the right hand side.

- ◇ *In the above example we used three minor option 017s. This is because fields 1 and 2 have multiple roles.*
- ◇ *017 changes the set values only until the end of the current MOSS session. To permanently modify the default values you will need to set the new values onto your parameter file.*

### Minor option 018 Define linear units

Redefines the units of linear measure, to allow model file information to be interpreted as metric units (metres) or as imperial units (feet).

Input

Graphics



Linemode

Minor option 018

- Field 1 MET - Model units interpreted as metres
- IMP - Model units interpreted as feet

- ◇ Further options are available within minor option 018 which are used only by major option GENIO and are described in Chapter 14.

## Minor option 019 Define string masking

Creates a table of string masks or adds to an existing one.

### String masks

To increase the power of some of the facilities in MOSS it is possible to select strings in groups from a model for subsequent processing.

The mechanism for selection is a 'mask', which consists of four characters that are compared with each string label or sub reference. The mask may be alphabetic, numeric and blank characters and any of the special characters valid within a string label or sub reference.

Each non-blank character in the mask is compared with the corresponding character in the string label or sub reference. If all the non-blank characters are the same in the mask and the label or sub reference, the mask is satisfied. The subsequent action depends on whether the mask is an 'inclusive mask' or an 'exclusive mask'; for an inclusive mask the string is accepted for further processing; for an exclusive mask the string is rejected.

With disciplined choice of string labels, masks can be very useful. For example, if all fence strings begin with F you can plot them from a ground model. You can choose to include strings with an inclusive mask or exclude them with an exclusive mask.

### Input

### Graphics

Define string masking
Mask label
Include/exclude (T)

Linemode

Minor option 019

- |         |  |
|---------|--|
| Field 1 | The mask consists of up to four alphabetic, numeric, blank or special characters   |
| Field 4 | +1.0 inclusive string label mask<br>-1.0 exclusive string label mask<br>+5.0 inclusive sub reference mask<br>-5.0 exclusive sub reference mask |

Major option TRIANGLE

- |         |   |
|---------|---|
| Field 4 | +2.0 interpret as P string<br>+3.0 interpret as linked string |
|---------|---|

Major option SURFACE

- |         |  |
|---------|--|
| Field 4 | +4.0 mask of strings which are to cause bearing discontinuities<br>-4.0 mask of strings which are not to cause bearing discontinuities |
|---------|--|

- ◇ *To select all strings, or to cancel the existing set of selection masks, or to reinitialise, leave all fields blank.*
- ◇ *49 masks may be created in the masks table.*
- ◇ *Masks will remain in effect for the duration of the major option in which they are set up.*
- ◇ *In any one major option you can set up and cancel masks tables at will.*
- ◇ *MOSS will check labels or sub references against each mask in the table in the order in which the masks are input. As soon as a mask is satisfied no further tests are made.*
- ◇ *If it is possible for a label or sub reference to satisfy more than one mask, the more restrictive should appear first. Usually this will be the mask with the most non-blank characters.*
- ◇ *A string will be included if, on reading the bottom of the mask table, no mask has been satisfied.*

Example 1

```
DRAW, SURVEY MODEL
019, H, 4=1.0
019, F, 4=1.0
019, 4=-1.0
```

This will select hedge strings (H) and fence strings (F) from the model called SURVEY MODEL. All other strings will be ignored.

Example 2

```
019
019, PTR, 4=1.0
```



```
019, P, 4=-1.0
019, 4=1.0
```

Of all the P strings in the model this will draw only the strings with characters PTR and any fourth character. All strings other than P will also be included.

The leading 019 clears the current mask.

### Example 3

```
019, T, 4=-1.0
019, P, 4=1.0
019, ST, 4=1.0
```

This contains an error because the first 019 excludes all strings which have the second character as T, whereas the third 019 includes strings beginning ST. The system will recognise and indicate this error. The data probably should have read:

```
019, ST, 4=1.0
019, T, 4=-1.0
019, P, 4=1.0
```

### Example 4

```
019, M001, 4=-5.0
019, M0, 4=5.0
```

This will select all strings with a sub-reference starting with the letters M0 except for those with a sub-reference of M001.

## Minor option 900 Invoke a macro option

Minor option 900 enables you to use a standard set of previously prepared data into which you assign basic values.

Fields 1 & 2 Name of macro (8 characters maximum)

This is a powerful feature and is described separately under major option MACRO. Please refer to Chapter 13.

## Minor option 999 End a major option

Used to mark the end of input data to a major option.

### Input

#### Minor option 999

There is no associated field data.

- ◇ *Option 999 should not be used with major options that have no associated minor option data.*

## Chapter 3 Drawing

### Drawing

MOSS was originally developed from a recognition that the computer could perform calculations other than those carried out by manual methods. Not only were new design techniques promoted and accepted but the benefits of providing the results in the form of computer generated drawings were apparent. Graphical output from computers has now become an established element of the design process and MOSS provides extensive graphic output in the form of plan, contour, perspectives, long and cross section drawings.

Initially graphics was limited to plots produced on drum or flat bed plotters and its use was restricted to contract drawings. Whilst the production of drawings is still essential the availability of high performance interactive graphics equipment makes it possible to communicate with the base model data through the drawing derived from it. It is recognised that great benefits can be gained from the engineer using a graphics terminal. Graphical display, enhancement and manipulation options must therefore provide:

1. Drafting facilities which give great flexibility and control over drawing content and layout.
2. The ability to interactively enhance the drawing by the addition of text and non-model information.
3. The ability to design and edit through facilities which are able to change the basic model data through interaction with the drawing.

Major option DRAW enables total flexibility in the development of drawings, creation of multiple drawings on the same sheet (composite), and customisation of drawings. This is complemented by Interactive MOSS (IGMODE) which allows points, individual strings and whole set of strings to be edited, designed, reported, enhanced, and manipulated.

One of the many major advantages of MOSS has been its availability across a wide range of computers by strict adherence to programming standards. For the same reason the internationally agreed graphics standard GKS, has been adopted.

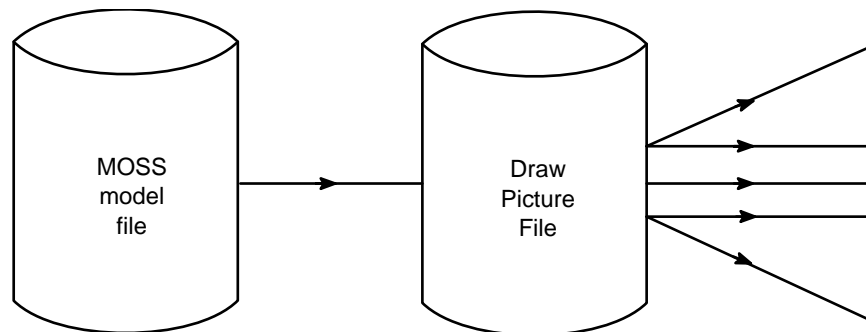
The DRAW option provides a flexible facility where no additional hardware or software is needed over and above a 'batch' environment. However, to obtain the greater benefits offered by the interactive system, intelligent graphics terminals and adequate computer resources and priorities are required.

## Concepts of drawing production

### The model file and picture file

The MOSS model file is central to all MOSS modelling and all options operate on it. Many of the options also use specific files derived from the model file.

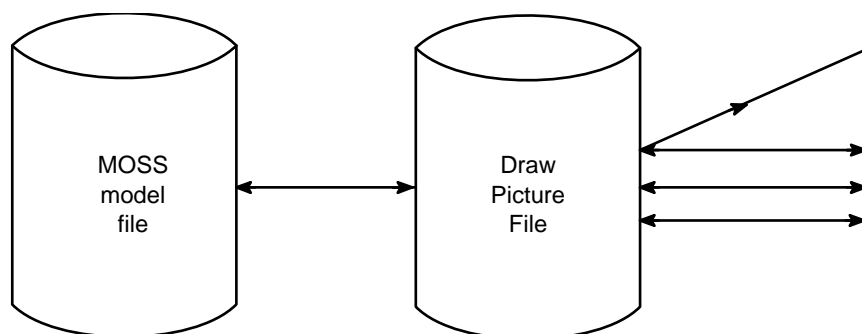
When producing drawings, an ancillary file containing both graphical data and model information is generated. This 'Draw Picture File' (DPF) is then operated on to produce a drawing. With early graphics systems the DPF provided a means by which a drawing could be previewed on a graphics terminal before plotting. This approach is shown in Figure 3 - 1.



**Figure 3 - 1 Early model file / DPF relationship**

Changes to the DPF could not be made and the drawings could not be enhanced before being plotted.

Interfaces were developed to take data from the DPF to drafting systems which were then used for graphical editing and enhancing. The disadvantage of this approach was that the editing and enhancing were one way only and the base model was not updated. These facilities are now provided in MOSS using the following approach.



**Figure 3 - 2 Current model file / DPF relationship**

The two way exchange allows changes to be made to the picture file and those changes which affect the model data are reflected in the model file.

The picture file performs a central role in extending the use of graphics beyond the production of pictures. The basic concepts may be summarised as:-

1. Produce a drawing.
2. Enhance a drawing.
3. Make changes to the contents of the drawing and reflect those changes in the model file.

A picture file is first produced using major option DRAW in either IGMODE or linemode. This includes setting up the drawing layout, content and possibly adding some enhancement. If linemode is used, interactive graphical facilities may then be used to display the picture file on a graphics terminal and carry out editing, enhancing and graphical manipulation.

When modifications are complete the picture file can be saved for subsequent plotting on a plotter. If any changes have been made to the model information contained in the picture file, the updated information is reflected in the model file.

The picture file is structured so that plan, contour drawings, perspective, long and cross section drawings are all compatible.

## Drawing production

There are seven stages to the production of a drawing.

1. Create a base picture from the model information stored on the MOSS database.
  - Major option DRAW
2. Divide the base picture into manageable drawing sheets.
  - Major option LAYOUT
3. Add to the base picture annotation and non-model related information.
  - Major option ENHANCE
4. Check, edit and modify the picture through graphical interaction.
  - IGMODE and/or Major option DISPLAY
  - Major options DISPLAY/IGMODE or stand alone program MSDISPLAY
5. Clip the drawing to remove superfluous information.
  - Major option CLIP
6. Produce a hard copy drawing of the picture.
  - Stand alone program MSPLOTTER
7. Produce a computer readable file for interfacing into other systems.
  - Major option or stand alone program MSMIFILE

These stages are not necessarily sequential but are iterative in the same way as the production of an engineering design is iterative.

Drawings are generated from within MOSS using the minor option commands of major option DRAW.

The DRAW commands build up a Draw Picture File known as a DPF. The DPF contains structured data associating line styles, colours and scales,

amongst other attributes, to the model information held on the engineering MOSS model file. The DPF is specifically independent of graphics terminals or workstations but contains all the information needed for a picture to be rapidly drawn on a targeted piece of graphics equipment.

In linemode only major options DRAW and ENHANCE will directly add information onto the DPF. In IGMODE (Interactive Graphics Mode), options invoked to alter data held on the MOSS model file will automatically update the DPF.

Once generated, the MOSS DPF may be visually presented on a particular piece of graphics equipment. There are two alternatives to achieve this:-

1. Enter IGMODE (Interactive Graphics Mode) whilst within MOSS and subsequently add, amend, delete or update both the drawing and the model(s) on which it is based.
2. Invoke major option DISPLAY. This option draws the information and will allow no updating of the picture.

The DISPLAY feature is available both within the MOSS program and as a separate stand alone program (MSDISPLAY).

A hard copy MOSS drawing may be generated directly from the DPF or clipped DPF if a program to drive the particular plotter is available. Such plotter drivers take advantage of the full functionality of individual plotters.

For transfer of the graphics information held on the DPF to complementary graphics systems, the MOSS Intermediate File (MIF) may be used. For further information see MSMIFILE (Chapter 14).

Graphics within MOSS

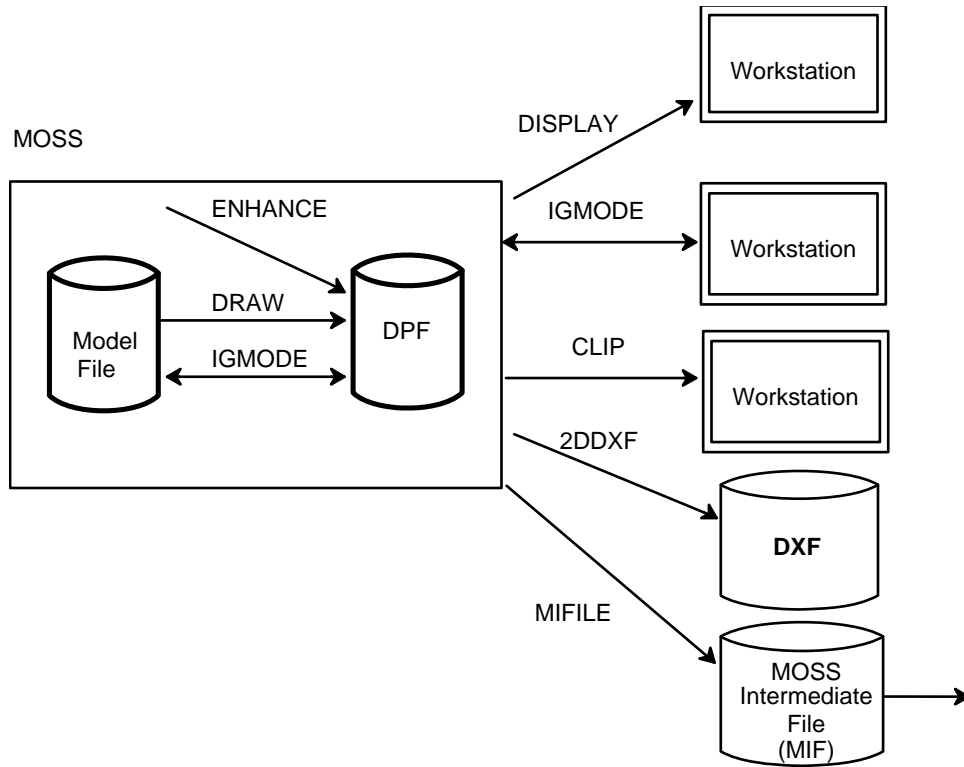


Figure 3 - 3 Graphics within MOSS

Graphics external to MOSS

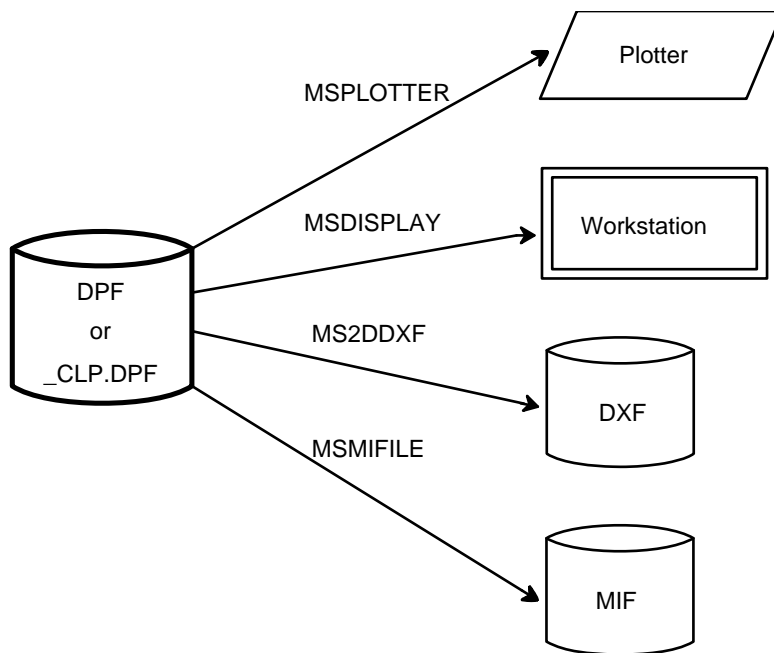


Figure 3 - 4 Graphics external to MOSS

## Data input

The graphics features offer a comprehensive range of alternatives both in layout, content and style of drawings. The user is able to define exactly how drawings should be produced, and to achieve complete flexibility a comprehensive set of minor options is provided. The majority of the minor options are common to plan, long section and cross section drawings with a minority having restricted application.

The flexibility provided conflicts with simplicity of use but the conflict is overcome by the use of macro commands. Users need not be aware of the detailed options used to set up a standard layout, but may be provided with a small set of macro commands and a list of necessary variables to be coded, for example, scales. By invoking the macro command with associated data the program will automatically expand the macro and generate all the minor options necessary to set up the drawing. Of course for those users who either wish to build their own specific macros or for a particular customised drawing, the full range of options is available.

## Graphics facilities in MOSS

### Interactive MOSS - IGMODE

Use of MOSS through the command language can be time consuming, particularly for the correction and perfection of survey and design models. Identification and referencing of data from a visual display followed by automatic implementation of a chosen function and redisplay of the amendment gives radical improvements to design efficiency. Interactive MOSS (IGMODE) interacts with the model file through the picture file and the software ensures compatibility between models and the pictures derived from them.

### Major option DRAW

DRAW works in two stages. First a picture of potentially unlimited size is created unrestricted by the physical limitations of the plotter or graphics equipment to be used. The second stage splits up the picture into physical sheets and interprets strings with either standard or user defined line types, symbols, text etc. The result is a series of sheets of drawings stored in a picture file. At this stage the information is still independent from any graphics device and can be directed to either a plotter or graphics display screen where the drawing may be manipulated interactively.

DRAW can produce the simple working drawings generated during the development of a design as well as drawings of surveys to cartographic standard and engineering drawings to contract document standard.

The simplest drawings require the minimum of minor option data, but as complexity is increased, further options allow greater control over the finished product. The option has been devised so that many of the

commonly used facilities may be simply invoked and installation conventions and standards may be automatically maintained.

The options provided include:-

- Drawing and sheet layout
  - Automatic paging
  - Automatic paging of overplots
  - Control of truncation
  - Specification of sheet sizes as standard A/B sheets
  - Global magnification of drawings
  - Adding of new pictures
- Relationship between model and drawing
  - Definition of scale, origin and rotation
  - Definition of model domain by boundary or maximum/minimum coordinates
- Environment conditions
  - Pen type and colour for lines/strings
  - Pen type and colour for text
  - Text characteristics (size, font (machine dependant) etc)
  - Line characteristics (line type)
  - Matching style and colour
  - Curve fitting
- Annotation
  - Definition of objects within a drawing
  - Margins
  - Grids (simple or user defined)
  - Frames (simple or user defined)
  - Strings with different styles
  - Type, size, position, layout and content of axis annotation
  - Coordinates
  - Multiple layers of annotation, symbols, pips etc
  - Hatching of areas



## Major option NEWDPF

Major option NEWDPF allows you to change the DPF on which you are working. It also allows a new dpf to be created if one of that name does not already exist.

## Major option NEWRPF

Major option NEWRPF allows you to change the Raster Picture File (RPF) on which you are working. It also allows a new rpf to be created if one of that name does not already exist.

## Major option ENHANCE

Major option ENHANCE provides a set of general purpose minor options to add, modify and delete parts of the drawing.

Interactive ENHANCE operates on the picture file produced by major option DRAW. The facilities are accessed by selecting functions from static and dynamic menu areas with a cursor driven by mouse, tablet or joystick.

The options provided include:-

- Graphics environment control
  - Line style
  - Line colours
  - Text style
  - Text colours
  - Text fonts
  - Hatching style
  - Hatching colour
  - Curve fitting
- Enhancement
  - Locating and moving text
  - Locating and moving symbols
  - Locating and moving boxes, circles etc
  - Hatching of symbols

## Major option CLIP

Major option CLIP creates a clipped copy of a DPF which can only be displayed or plotted. Elements designated as clip polygons erase any part of an erasable element which lies within their boundary. This is particularly useful for removing information from annotation and cadastral symbols.

## Major option LAYOUT

At the initiation of a scheme's design, or before producing final contract drawings, considerable thought needs to be given to the overall arrangement and management of drawing sheets. To assist the user in assessing the most favourable layout of the drawing sheets and to output

the necessary DRAW details, major option LAYOUT is provided. LAYOUT operates from within IGMODE. Usual practice will be to draw either the whole model or the extents of its boundary at small scale and then superimpose an outline of the drawing sheets as they would appear at a larger scale.

## Major option DISPLAY

DISPLAY is used to preview drawings on a graphics terminal before the drawing is produced on a plotter or hard copy device. DISPLAY cannot change any part of the drawing.

DISPLAY exists both as a major option within MOSS and as a stand alone program (MSDISPLAY).

To use the standalone program, type MSDISPLAY [return], you will be prompted for the name of the DPF to display.

On some systems a further version of DISPLAY may exist. Whilst within MOSS a SUBSYSTEM function SUBDISP permits you to display a DPF other than the current file. In every respect, however, SUBDISP operates identically to the stand alone program MSDISPLAY.

The use of DISPLAY either within MOSS or externally is controlled through a series of simple menus. The following features are available.

- Windowing
  - Defined opposite corners.
  - Zoom factor in or out.
  - Actual scale representation.
  - Definition of point to become centre.
- Multipage
  - Selection of the page to be displayed
  - next, previous, defined page.
- Multiple Use
  - Within MOSS a picture may be built up by using MOSS options and then using DRAW and/or ENHANCE commands with intermediate previewing, via DISPLAY. This is particularly useful during the build up of a design as each stage may be monitored.

## MSPLOTTER

The MSPLOTTER program accesses the DPF (Draw Picture File) and produces a drawing on a plotter. Unlike DISPLAY which operates both as a major option and as a stand alone program, MSPLOTTER only operates as a stand alone program. However, on some systems a SUBSYSTEM function SUBPLOT permits you to access the stand alone program from within MOSS. In every respect SUBPLOT operates identically to MSPLOTTER.

Different plotter manufacturers supply different protocols to drive their equipment, in the form of standard subroutine calls. Program MSPLOTTER

is supplied to users in such a form that specific MSPLOTTER drivers may easily be produced. For the more popular plotters the complete program may be supplied but if a plotter driver does not exist, a 'Plotter Kit' may be supplied.

The use of MSPLOTTER is controlled through a series of simple menus, which allow specific pages to be drawn.

The actual administration of plotting varies from one installation to another and your System Manager will clarify your particular arrangements.

## Major option IDIGIT

In the initial data collection process of recording existing surface details common practise is to digitise already prepared drawings. Major option IDIGIT permits the transformation of string information recorded in locally digitised coordinates into the required real coordinate system.

A major advantage of IDIGIT (Interactive Digitising) is that some of the MOSS interactive facilities are available whilst generating the model. The model and the drawing are created simultaneously and any errors may be visually identified and corrected. The option operates within IGMODE and various menus guide and prompt you through the facilities available. A detailed description of this option is given in Chapter 5.

◇ *This major option is not supplied as a standard MOSS option. It may be purchased as a chargeable extra.*

## Major option MIFILE

Other application packages and particularly some drafting packages supply facilities which are not readily available within MOSS. These complementary systems, need to access the graphic information held on the DPF. The information however, must be simplified as the DPF also holds model relationships.

The MOSS Intermediate File (MIF) is an ASCII representation of the DPF (Draw Picture File) and may be accessed by other complementary computer graphics programs. The MIF file contains all the information to reconstitute a drawing be it a plan drawing, sections or perspective views, or even a composite of all types. It is likely that complementary programs will provide a feature to read the MOSS Intermediate File and generate a graphical database from the information supplied.

If you have such a complementary package to MOSS, your System Manager should be able to help achieve the communications between it and MOSS.

Major option MIFILE is supplied to create the MIF file.

◇ *This major option is not supplied as a standard MOSS option. It may be purchased as a chargeable extra.*

## MS2DDXF

A stand alone program MS2DDXF accesses the MIFILE output file. It produces a file in DXF format suitable for AUTOCAD and other compatible systems. It allows the user to maintain the drawing layers defined with DRAW and ENHANCE data within the drafting package.

- ◇ *This major option is not supplied as a standard MOSS option. It may be purchased as a chargeable extra.*

## Major option NEWDPF

Major option NEWDPF allows you to change the current DPF. This means you may change the model or change the view you have of the current model.

NEWDPF is an option on the DRAW options menu.

Selecting NEWDPF will open one of two dialogues depending on whether you specify

- the name of an existing DPF
  - the name of a non-existent DPF
- and
- the current DPF displayed

### Input

### Graphics

Drawing Options
DRAW Working Drawings
DRAW Contract Drawings
ENHANCE Drawings
Add annotation
CLIP drawings
LAYOUT
Drawing sheets
MACROSYMBOLS
Create/amend/store
VIEW
Perspective/Photo
VISUALISE
Prepare EPIC data
2DDXF
DPF conversion to DXF
NEW DPF Select DPF
NEW RPF Select RPF
REPORT
Models/strings/points

### IGGENLT.DAT, GEN005

When you select NEWDPF the prompt 'Type the name of the file to be used, return to quit option', is displayed.

### Linemode

Model 1      Name of DPF file to be opened

                 If blank, the name of the currently open DPF is reported.

There are no associated minor options.

◇ *NEWDPF closes the current RPF.*

◇ *If an RPF of the same name exists, it will also be opened.*

## Existing DPF

If you type the name of an **existing DPF** eg filename.dpf the file will be opened and displayed together with the message 'opened filename.dpf'. You may select any of the DRAW options but

- a request to draw any string that extends beyond the DPF will result in that string being clipped to the DPF minimum and maximum coordinates
- window may be used to zoom in and out
- changes made to string information using EDIT will be actioned within the model.

If you type the name of an **existing but empty DPF** eg filename.dpf the file will be opened and displayed together with the prompt 'opened EMPTY.DPF filename.dpf'. You may select any of the DRAW options but

- the maximum and minimum coordinates of the DPF will be continually adjusted to cope with any added strings
- the maximum and minimum coordinates of the DPF will be continually adjusted to cope with any deleted strings
- window may be used to zoom in and out
- changes made to string information using EDIT will be actioned within the model.

## Non-existent DPF

If you type the name of a **non-existent DPF** file eg empty.dpf the system will respond 'file not found. Do you wish to create it? (Y/N default Y). If you type Y the file will be created, opened and displayed together with the prompt 'opened EMPTY DPF filename.dpf'. You may select any of the DRAW options but:

- the maximum and minimum coordinates of the DPF will be continually adjusted to cope with any added strings
- the maximum and minimum coordinates of the DPF will be continually adjusted to cope with any deleted strings
- window may be used to zoom in and out
- changes made to string information using EDIT will be actioned within the model.
- the current DPF displayed when NEWDPF is selected will be closed and -
- all changes made to the dpf will be retained
- all changes relevant to the model will be retained in the model.

# Major option NEWRPF

Major option NEWRPF allows you to change the current Raster Picture File (RPF). The RPF is a picture file for TIFF images drawn with minor option 831, 'Draw raster backcloth'.

NEWRPF functions in a similar fashion to major option NEWDPF.

**Input**

Graphics

IGGENLT.DAT, GEN005

Drawing Options
DRAW Working Drawings
DRAW Contract Drawings
ENHANCE Drawings
Add annotation
CLIP drawings
LAYOUT
Drawing sheets
MACROSYMBOLS
Create/amend/store
VIEW
Perspective/Photo
VISUALISE
Prepare EPIC data
2DDXF
DPF conversion to DXF
NEW DPF Select DPF
NEW RPF Select RPF
REPORT
Models/strings/points

When you select NEWRPF the prompt 'Type the name of the file to be used, return to quit option', is displayed.

Linemode

Model 1      Name of RPF file to be opened

                 If left blank, the currently open RPF file is closed.

There are no associated minor options.

- ◇ *The default RPF name is DRAW.RPF*
- ◇ *To close an RPF in IGMODE, type a blank file name.*
- ◇ *Major option NEWDPF closes the current RPF and opens the RPF of the same name as the specified DPF if the RPF exists.*
- ◇ *DPF's and RPF's specified together must have exactly the same domain.*
- ◇ *On exit from MOSS, you are given the opportunity to rename both the DPF and RPF files. If you rename the DPF file, the RPF file will be given the same name by default.*

## DRAW macros

Major option DRAW provides complete control over drawing content, layout and annotation. This flexibility is achieved by providing a large number of minor option commands, each containing many variable data items. It is recognised that many organisations will have defined standard drawing layouts and annotation conventions which will be used repeatedly.

To minimise the data entry to major option DRAW two facilities are provided. First an installation may choose the default values of many of the data items in DRAW. These are assigned at the time of installation and may be automatically recalled. For example it may be chosen to produce all drawings at A0 size and if this is defined as the default it will be used in the absence of any overriding value.

A second facility is provided for use where sets of minor options are used repeatedly. To avoid repetition of data which will remain standard, macro options or 'macros' may be set up. The data items of the minor option records are given variable names and when a macro option is used the series of minor options stored in the macro are invoked with values substituted for any defined variables. The resultant MOSS minor options are then processed in the normal way.

### For example

If you input:

```
DRAW, SIMPLE DESIGN GROUND
900, PLANDRAW
SC=500
999
```

you will obtain the following output:

```
DRAW      SIMPLE DESIGN GROUND
900PLANDRAW
SC=500
000800, , , , 1, , ,
000801, OVER
802      1      1      1      1 M
803PLAN      500      M
804PLAN      M
821      M
822CROS      100  100      M
805      M
806      M
825      M
999
```

- ◇ 000 in columns 1 to 3 denotes a line which is commented out and therefore not expanded from free to fixed format
- ◇ M in column 81 denotes expanded macro data



Once created, macros substantially reduce the amount of data to be specified and considerably increase the power of the data input into MOSS. Macros facilitate the adoption of standard layouts and drawing office practice and reduce data entry. Experienced users of the DRAW options will design and construct their own macros. Standard macros have been developed as an aid to general users.

Standard Macros supplied with the MOSS System are:

900,PLANDRAW	Plan drawing.
900,PLANLINE	Addition of string to a plan drawing.
900,LONGDRAW	Longitudinal section drawings.
900,LONGLINE	Addition of further section to a longitudinal section drawing
900,SECTDRAW	Drawing of cross sections.
900,SECTLINE	Addition of further sections to cross section drawings.
900,ORDSDRAW	Standard drawing of OS1988 large scale digital maps.
900,SURVDRAW	Production of a standard survey drawing.
900,MASSDRAW	Graphical presentation of Mass Haul analysis.
900,PLANDRAI	Plan drawing of a drainage network.
900,LONGDRAI	Long section drawing of a drainage network.

The above macros are provided for direct use; however the following macros have also been developed. These are:-

900,FRAMEA1	Addition of a user defined frame to a drawing.
900,FRAMHELP	Description of the workings of FRAMEA1.
900,TITLE	Addition of a user defined Title block.

These are provided to help users in preparing their own frame macros.

The standard macros provided with the system may not always satisfy a users requirements. Users wishing to alter these standard macros or develop their own macros should refer to Chapter 13.

Associated with the 'command' macros are a number of 'drawing symbol' and 'drawing line' macros which must be present in order to run the above command macros.

The data necessary to load the command and drawing macros is provided with the distributed system.

Data input to a macro uses two character field descriptors for individual items of data.

For example SC=500 requests a scale of 1/500.

XL=1500,YL=2000,BE=270 would be interpreted as the model coordinates of the bottom left corner of the drawing window with a bearing of the left hand side being 270 degrees.

There are some simple rules to follow in assigning data to variables:-

1. All fields must be separated by commas.
2. There must be no blanks between fields.

3. If an assignment is to be made to a character variable and the value contains embedded blanks, then the value must be surrounded by single quotes.

For example A='AB D'

4. As many variable assignment records may be used as are necessary but each must terminate with a comma except the last which must end with a blank.
5. If no variables are to be assigned, ie all the default values are to be used then there must be one assignment record with a single character asterisk in column one.
6. If a variable name exists within a macro and no default value is given and no value is assigned when using this option, the field descriptor will appear in the resulting record, and the data may well fail.
7. In order to differentiate input derived from macros from standard input data the derived minor options are marked with an M.

### Examples

```
DRAW, SIMPLE DESIGN GROUND  
900, PLANDRAW  
SC=1000, XL=500  
999
```

```
DRAW, SIMPLE DESIGN GROUND  
900, PLANDRAW  
SC=1000, XL=1500, YL=2000, BE=270  
999
```

## Access to DRAW using MACROS

### Input

### Graphics

The following description relates to any of the macros available for drawing.

PLANDRAW	SURVDRAW	PLANDRAI	LONGLINE
LONGDRAW	MASSDRAW	LONGDRAI	SECTLINE
SECTDRAW	ORDSDRAW	PLANLINE	

The procedure is simple, however it will probably be necessary to refer to the individual macro documentation to ascertain the two character code required.

**GEN 005, DRW 004**

Drawing options	DRAW - Option details
DRAW Working Drawings	Model for DRAW
DRAW Contract Drawings	Draw All Strings
ENHANCE Drawings	Draw All Strings (DETA)
Add annotator	Draw selected strings
CLIP drawings	Draw using a macro
LAYOUT	Define a boundary
Drawing sheets	Add drawing details
MACROSYMBOLS	Create new sheet
Create/amend/store	End Draw
VIEW	
Perspective/Photo	
VISUALISE	
Prepare EPIC data	
DDXF	
DPF conversion to DXf	
VIEW DPF Select DPF	
VIEW RPF Select RPF	
REPORT	
Models/strings/points	

When you select 'Draw using a macro' the system prompts 'Enter a macroname or return to quit'.

Type eg PLANDRAW

The system prompts you with a list of two character codes.

Select those required then proceed.

The alpha plane will automatically appear and display progress.

When the DPF is drawn the alpha plane is closed and the prompt 'Return to continue' allows you to type return and continue.

**Linemode**

The Linemode details for macros, PLANDRAW, PLANLINE, LONGDRAW, LONGLINE, SECTDRAW, SECTLINE, SURVDRAW follow.

The Linemode details for macros PLANDRAI and LONGDRAI are given in Chapter 12.

The Linemode details for macro ORDSDRAW are given in Chapter 14.

**Plan Drawings**

A standard drawing may be produced by invoking the macro PLANDRAW. A wide variety of alternatives is accommodated in this macro including overplotting of several models.

**Macro PLANDRAW**

Example of use

900 , PLANDRAW

SC=500 , LC=RED , TC=RED , DE=DETA

Attributes may be assigned but if they are not relevant or of no interest they may be ignored.

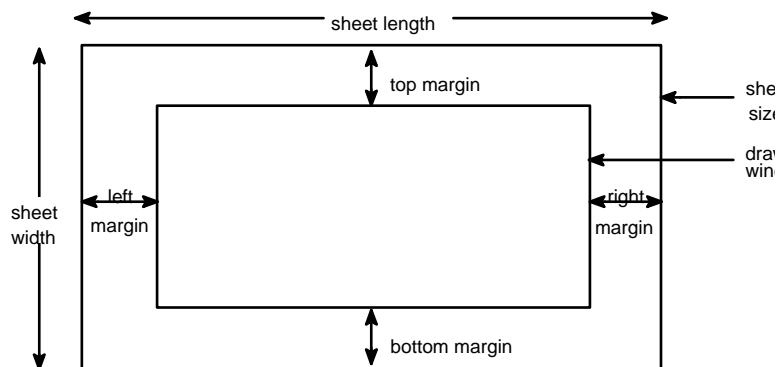
In the following

PV implies any Positive Value.

CV implies any Character Value.

PF implies the Parameter File default will be used.

**Input data**



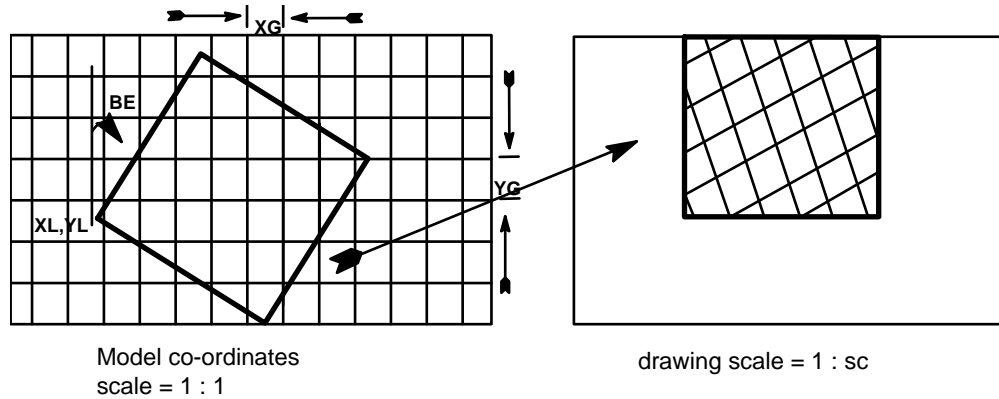
**Figure 3 - 5 Drawing sheet parameters**

Code	Description	Alternatives	Default
FD	First drawing if there is overplotting or if SL or SW are to be specified	"	-
OD	Subsequent drawing if there is overplotting	"	-
TR	Truncation or no truncation (of sheet area)	TRUN NOTR	PF
SL	Sheet length	PV	PF
SW	Sheet width	PV	PF
FR	Draw aframe Do not draw a frame Put registration marks on single sheet Draw frame around windows	FRAM NOFR REGR WIND	PF
ML	Left margin	PV	1.0
MB	Bottom margin	PV	1.0

MT	Top margin	PV	1.0
MR	Right margin	PV	1.0
PA	Paged or non-paged drawing	PAGE	PF
		NOPA	

- ◇ *If SL is assigned but not SW an A size sheet is specified.  
If SW is assigned but not SL a B size sheet is specified*

Drawing details



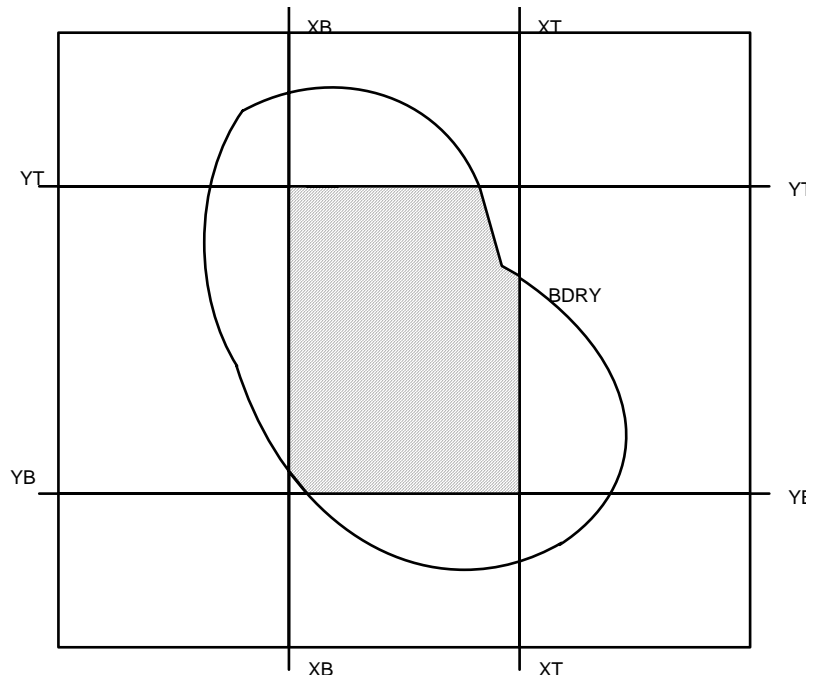
**Figure 3 - 6 Drawing details**

Code	Description	Alternatives	Default
SC	Scale	PV	-
XL	Relationship of model to drawing window.	PV	Minimum
YL	Coordinates of bottom left point and	PV	model
BE	bearing of left hand side	PV	coordinates: bearing zero
LC	String colour	CV	BLACK
TC	Text colour	CV	BLACK
GR	Grid with edge ticks	EDGE	CROS
	Grid with crosses at intersections	CROS	
	Full line grid	FULL	
	Do not draw a grid	NOGR	
XG	X spacing interval of grid	PV	100
YG	Y spacing interval of grid	PV	100

Model details

Code	Description	Alternatives	Default
IO	Plot inside or outside a boundary	IN OUT	-
BD	Boundary string label if IO=IN or IO=OUT	CV	-
XB	Minimum model coordinate restricting	PV	0.0
YB	region to be drawn	PV	0.0
XT	Maximum model coordinates restricting	PV	99999999.9
YT	region to be drawn	PV	99999999.9
LB	Label of string to be drawn (if not coded, strings obeying any masks will be drawn).	CV	

LA	Annotate strings with label at start Annotate strings with label at both ends Do not annotate label Annotate contour strings with level at start Annotate contour strings with level at both ends	LABS LABL NOLA LEVS LEVB	PF
DE	Draw the information according to detail defined. Detail interpretation to all strings Contours with height embedded Pip marks at each point Cross and level at each point Spot level with decimal point marking position.	DETA CONP PIPS SPOT SPDP	-
PS	Pip size	PV	-
IN	Pip or chainage marking interval	PV	-



**Figure 3 - 7 Example - restricting drawing area**

◇ *The only mandatory variable is SC, the scale.*

## Macro PLANLINE

### Example of use

```
900, PLANLINE
LC=BLUE, TC=BLUE, LB=M001
```

Attributes are assigned similar to PLANDRAW. Again if they are not relevant or of no interest they may be ignored.

### Input data

#### Drawing details

Code	Description	Alternatives	Default
LC	Line and string colour	CV	BLACK
TC	Text colour	CV	BLACK
FR	Draw a frame	FRAM	PF
	Do not draw a frame	NOFR	
	Put registration marks on sheet edge	REGR	
	Draw frame around windows	WIND	

#### Model details

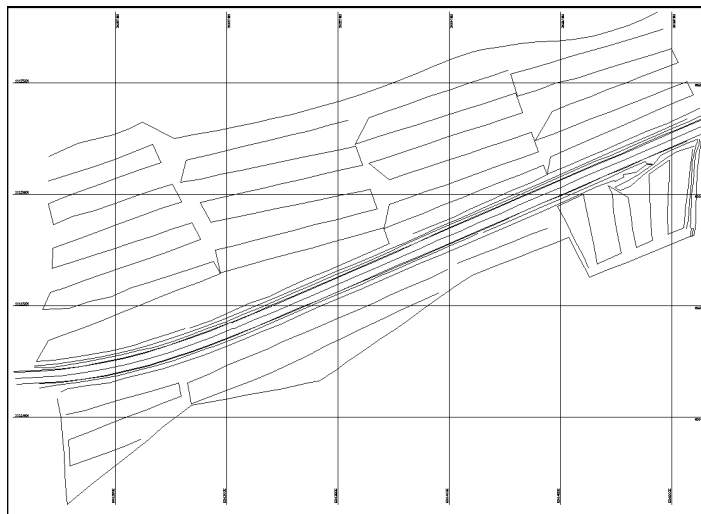
Code	Description	Alternatives	Default
LB	Label of string to be drawn (if not coded, strings obeying any masks will be drawn)	CV	-
LA	Annotate strings with label at start	LABS	PF
	Annotate strings with label at both ends	LABL	
	Do not annotate labels	NOLA	
	Annotate contour strings with level at start	LEVS	
	Annotate contour strings with levels at both ends	LEV B	
PS	Pip size	PV	-
IN	Pip or chainage marking interval	PV	-
DE	Draw the information according to detail defined:		-
	Detail interpretation to all strings	DETA	
	Contours with height embedded	CONP	
	Pip marks at each point	PIPS	
	Cross and level at each point	SPOT	
	Spot level with decimal point marking position.	SPDP	

**Example 1 Simple drawing**

To produce a drawing employing all the MACRO defaults and the installation defaults; only a scale, specified as the inverse of that required (eg 500.0 for 1/500 scale), need be given. Note that the name of the model to be plotted appears on the major option.

```

DRAW, SIMPLE DESIGN GROUND
900, PLANDRAW
SC=500
999
    
```



**Figure 3 - 8 Simple drawing - MACRO defaults**

**Example 2 Simple drawing changing colour and adding a full grid**

Each assignment is separated from the next by a comma and as many records as are necessary may be used. Each record must terminate with a comma except the last which must end with a blank space.

```

DRAW, SIMPLE DESIGN GROUND
900, PLANDRAW
SC=500, LC=GREEN, GR=FULL, XG=50, YG=50
999
    
```



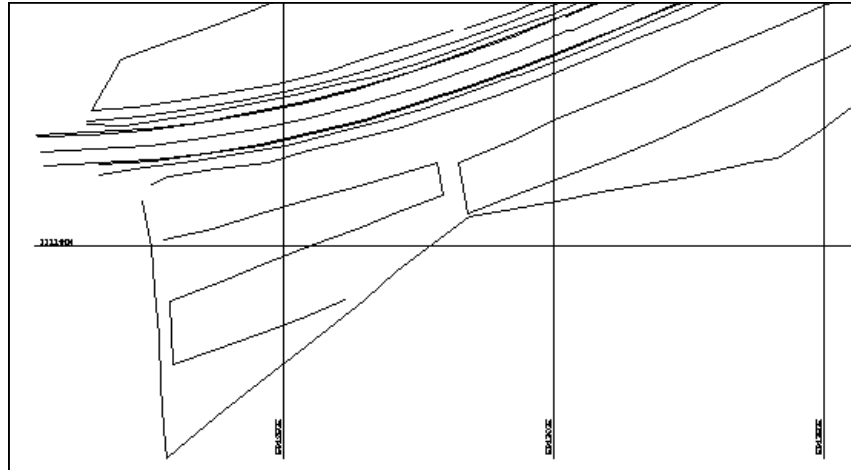
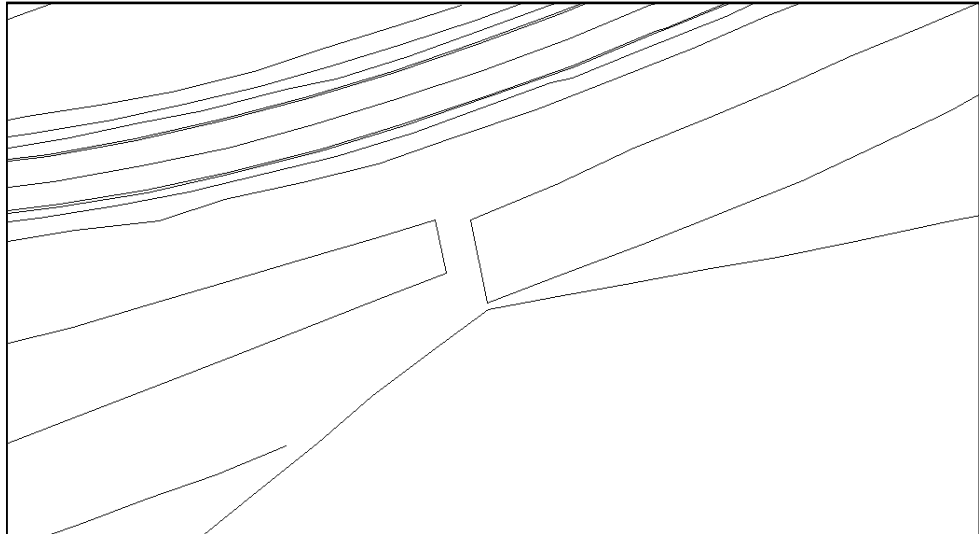


Figure 3 - 9 Simple drawing changing colour and adding a full grid

**Example 3 Selection of part of the model to be drawn by the specification of maximum and minimum coordinates**

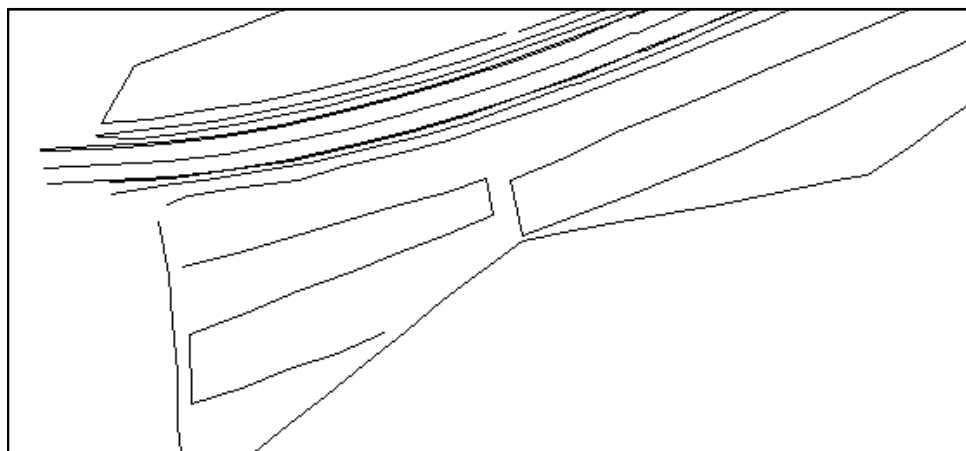
```
DRAW, SIMPLE DESIGN GROUND  
900, PLANDRAW  
SC=500, XB=501230, YB=111080, XT=501340, YT=111140,  
XL=501230, YL=111080, GR=NOGR
```



**Figure 3 - 10 Part of model by maximum and minimum coordinates**

**Example 4 Selection of part of the model by the bottom left corner of the drawing**

```
DRAW, SIMPLE DESIGN GROUND  
900, PLANDRAW  
SC=500, XL=501200, YL=111070, GR=NOGR  
999
```



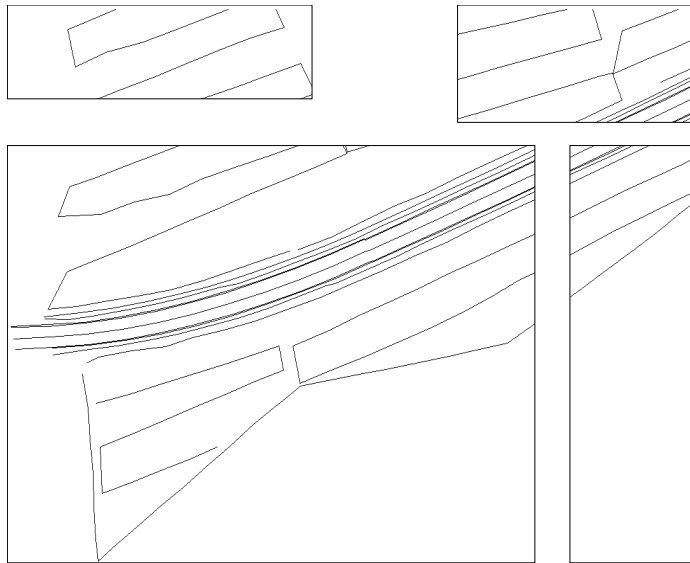
**Figure 3 - 11 Part of model by bottom left hand corner**

**Example 5 Producing multi sheet drawings**

If the area of interest to be plotted will not fit on one sheet the system can be made to produce as many sheets as are necessary to contain the area of interest. In this example, the drawing sheet size is also changed to 40 x 30 cms.

```

DRAW, SIMPLE DESIGN GROUND
900, PLANDRAW
FD= ' ', PA=PAGE, SL=40, SW=30, SC=500, GR=NOGR
999
    
```



**Figure 3 - 12 Multi sheet drawings**

**Example 6 Rotation of the drawing window relative to the model axes**

By default the left hand side and bottom of the drawing window are aligned due north and due east respectively. The drawing window may be rotated through any angle by coding the required angle of rotation. The angle is that between due north and the required direction of the left hand side of the drawing window; the window being rotated in a clockwise direction. The easiest way to arrive at this information is to place a frame over the area of interest, decide which is to be the bottom left hand corner to the window, then calculate the bearing of the left hand side of the window.

The drawing may be rotated only if the bottom left hand corner coordinates (XL and YL) are explicitly coded.

```

DRAW, SIMPLE DESIGN GROUND
900, PLANDRAW
SC=500, XL=501230, YL=111058, BE=340
999
    
```

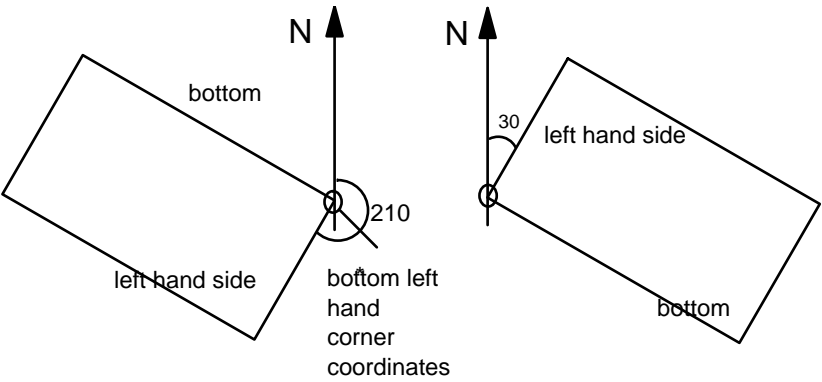
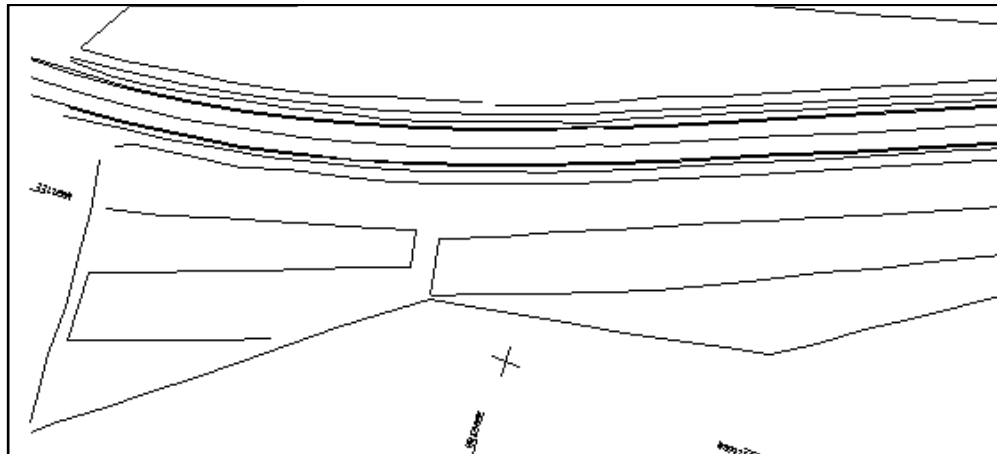


Figure 3 - 13 Window rotation

The effect of rotating the window is shown in Figure 3 - 13.

- ◇ *(XL, YL) are different from (XB, YB). (XL, YL) dictate the bottom left coordinates related to the drawing window whereas (XB, YB) dictate the minimum coordinates of the region to be drawn.*
- ◇ *It is possible to use automatic paging with notation only if the bottom left hand of the initial page is explicitly coded.*



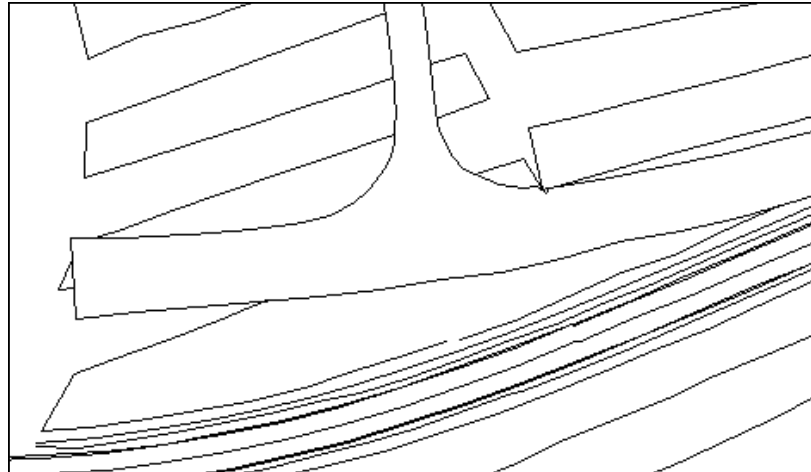
**Figure 3 - 14** Rotation relative to model axes

### Example 7 Selection of the area to be drawn by a boundary string

A boundary may be defined and all the model information outside or inside it may be selected for drawing. This is particularly useful when generating composite drawing eg ground information outside a boundary and proposed new construction within.

```

DRAW, SIMPLE DESIGN GROUND, SIMPLE DESIGN BOUNDARIES
900, PLANDRAW
SC=500, IO=OUT, BD=BOND
999
DRAW, SIMPLE DESIGN BOUNDARIES
900, PLANLINE
LB=BOND
999
    
```

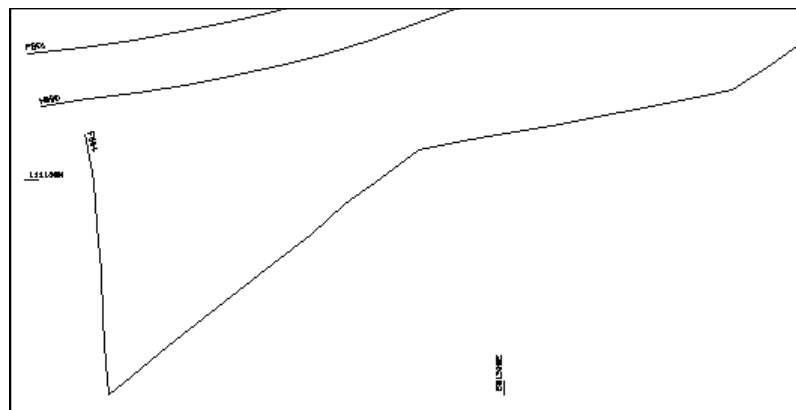


**Figure 3 - 15 Drawing area selected by boundary string**

### **Example 8 Selection of strings to be drawn within the area**

Strings may be included or excluded using global minor option 019 Define selection mask.

```
DRAW, SIMPLE DESIGN GROUND  
019, F, 4=1  
019, H, 4=1  
019, 4=-1  
900, PLANDRAW  
SC=500, LA=LABL  
999
```



**Figure 3 - 16 Drawing selected strings**

### **Example 9 Detail interpretation**

Detail interpretation (automatic line-styles) is the drawing of certain strings according to the first character of the string label, or some other feature

stored on the string such as the sub reference or the number of dimensions. It is usually invoked by coding "DETA" in field 2 of minor option 825.

The following are interpreted according to the first character of the string label:

C	Carriageway	Solid line
D	Ditch	Medium length dashed line
F	Fence	Long dashed line with alternate short dashes at right angles
H	Hedge	Interpretation according to a user defined macroline named HEDGE: if the macro HEDGE is not present in the macro file a solid line is produced.
L	Levels	String represented by a cross with levels drawn
M	Master	(6D strings only) solid line, curve fitted to a tolerance of 0.025. Chainage marking can be invoked.
P	Point Strings	Plotted as individual points with no connecting lines. Each point is annotated with the second and third characters of the string label, unless they are both numeric whereby the point sequence numbers are drawn.
PSS	Survey Stations	Drawn as a centred triangle with the station name and elevation.
V	Verge	Short dashed line.

Other detail interpreted strings:

*Interface strings*

The subreference is INTx and there are 5 dimensions. The string is drawn as a chain dashed line. A second string is automatically generated and drawn normal to the level datum string using the tadpole macroline. If the tadpole macro is not present, a solid line is drawn.

*Survey strings*

Those strings which have been created within Major option SURVEY are interpreted according to their contents indicator, ie only strings created with minor option 202 will be curve fit. The chord to arc tolerance used is 0.025. Note that a discontinuity of bearing will be maintained.

*Geometry strings*

These must hold 12 dimensions. The string label must begin with G, and the subreference must begin with M. Geometry strings are automatically interpreted as horizontal tangent points by minor option 825 with or without DETA.

Geometry strings can hold all relevant information about an alignment eg. both horizontal and vertical tangent points. In order to extract the required information extension cards must be coded for certain options, which contain a relevant code. These are documented under each applicable option.

STRING LABELS  
DRAW, SIMPLE DESIGN GROUND  
900, PLANDRAW  
SC=500, DE=DETA  
999

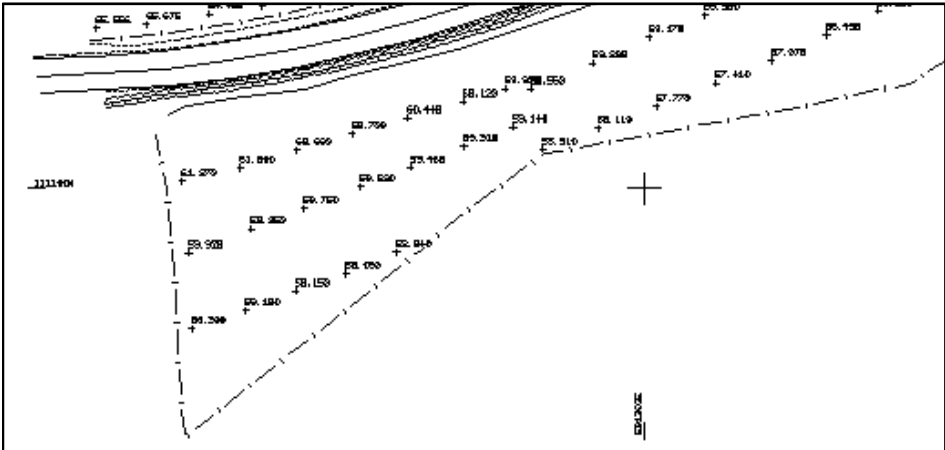


Figure 3 - 17 Detail interpretation



**Example 10 Pipemarks drawn at all string points**

A 'pip' mark is a short line drawn at right angles to a string at a string point. By default every pip is annotated with the point sequence number.

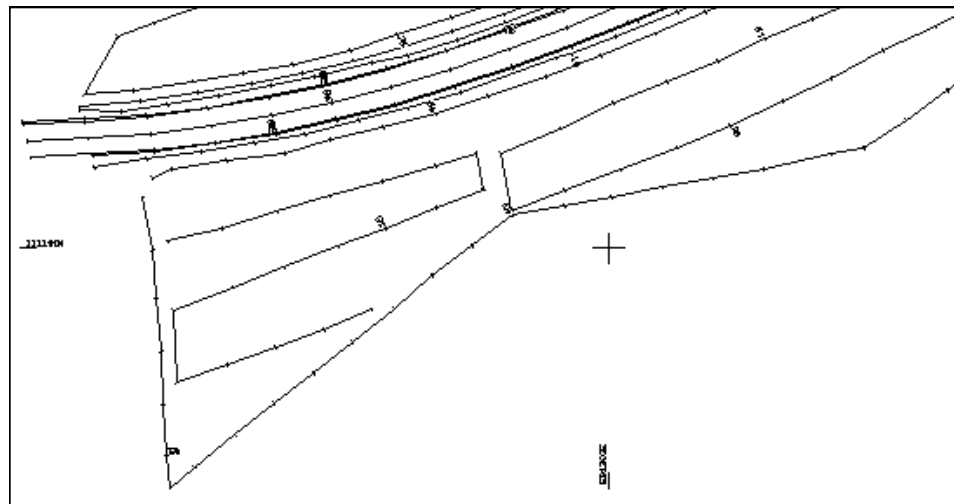
```
DRAW, SIMPLE DESIGN GROUND
```

```
PIPS ARE AT EVERY BUT POINT NUMBER EVERY TENTH
```

```
900, PLANDRAW
```

```
SC=500, DE=PIPS, IN=10
```

```
999
```



**Figure 3 - 18 Drawing with pip marks**

**Example 11 Strings drawn as spot levels**

```
DRAW, SIMPLE DESIGN GROUND
```

```
900, PLANDRAW
```

```
SC=500, DE=SPOT
```

```
999
```

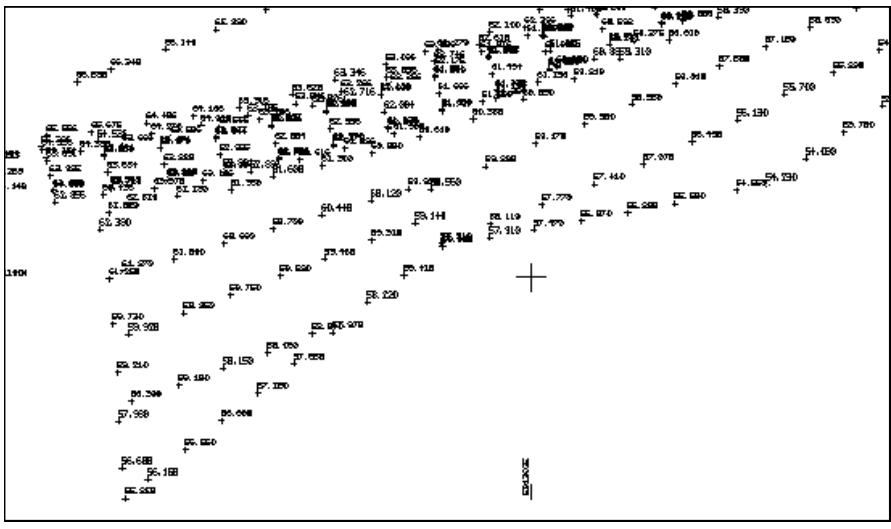


Figure 3 - 19 Drawing strings as spot levels

**Example 12 Plot string labels at the ends of the string**

By default string labels are not included on the drawings but they are often needed for identifying errors etc.

```

DRAW, SIMPLE DESIGN GROUND
900, PLANDRAW
SC=500, LA=LABL
999

```

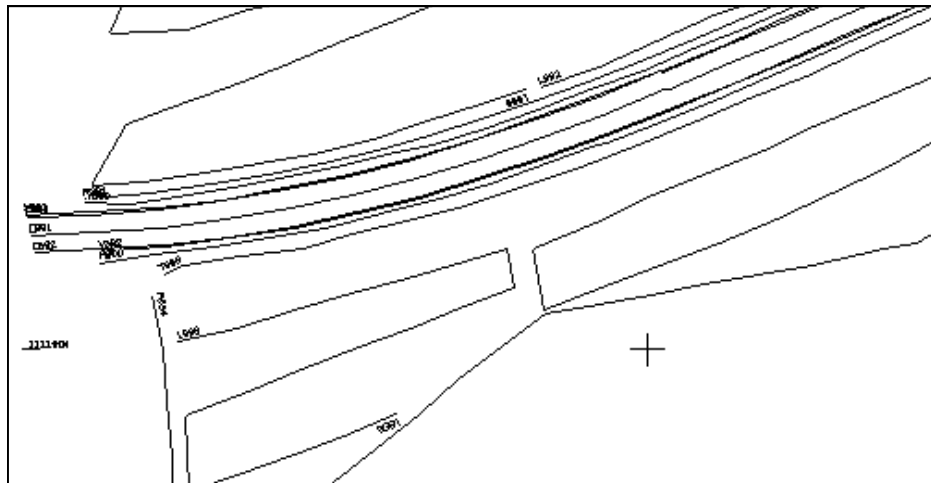


Figure 3 - 20 Drawing strings with labels at ends

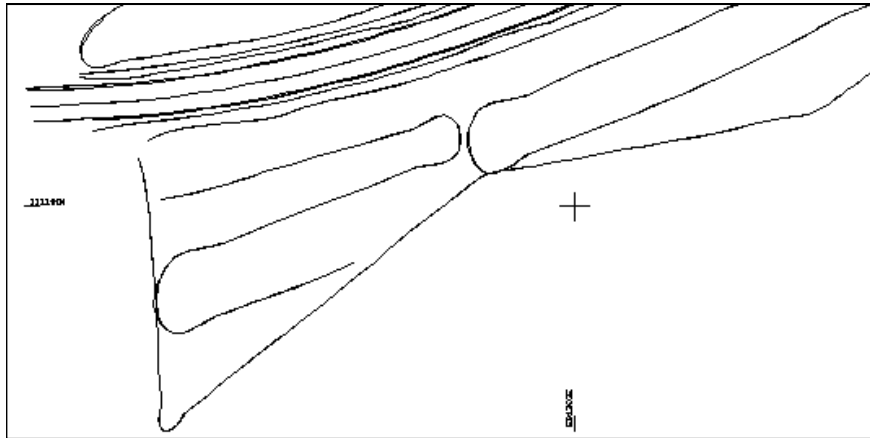
**Example 13 Apply curve fitting**

Two styles of curve fitting may be applied. The first style 'MOSS' ensures continuity of both bearing and radius throughout a string. The second style 'SPLI' ensures continuity of bearing only. In both cases a chord to arc tolerance determines the number of points needing to be added. By default

curve fitting is not applied and consecutive points are joined by straight lines.

```

DRAW, SIMPLE DESIGN GROUND
812, MOSS, 4=0.01
900, PLANDRAW
SC=500, LC=GREE
DRAW, SIMPLE DESIGN GROUND
812, SPL1, 4=0.01
900, PLANLINE
LC=RED
999
    
```



**Figure 3 - 21 Drawing strings with curve fitting**

**Example 14 Apply special line type to strings**

Major option DRAW operates with the convention of setting an environment, drawing some strings, changing the environment and then drawing more strings.

```

DRAW, SIMPLE DESIGN GROUND
    DASHED LINE OF 0.1 CMS LENGTH
810, DASH, 5=0.1, 0.1, 0.0, 0.1, 0.1
900, PLANDRAW
SC=500
999
    
```

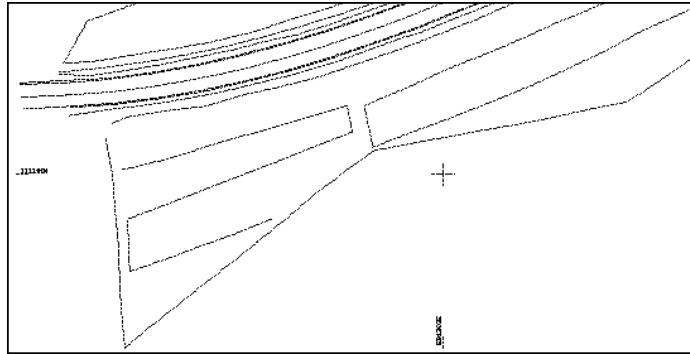


Figure 3 - 22 Drawing string with special line type

### Example 15 Overplot of model information

Drawings may be superimposed on one another in two distinct ways. First when the contents of two or more models are to be combined on the same drawing and secondly when the different parts of the same model are to be drawn in different ways, for example different strings in different colours. This last requirement is considered standard and until a new major option call dictates that the new drawing is to be produced, all plotted information is included automatically on the same drawing.

The command `FD = ''` is the technique used in the macro commands to dictate that FD (first drawing) is required. The `PLANLINE` macro should be used for overdrawing.

```

DRAW, SIMPLE DESIGN GROUND
810, DASH, 5=0.1, 0.1, 0.0, 0.1, 0.1
900, PLANDRAW
FD='', SC=500
999
DRAW, SIMPLE DESIGN ROAD
810, DASH, 5=1.0, 0.1, 0.0, 0.1, 0.1
900, PLANLINE
SC=500
999
    
```

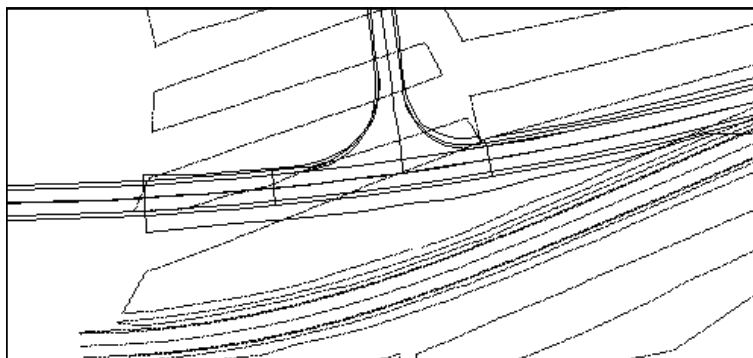


Figure 3 - 23 Drawing with overplot of model information

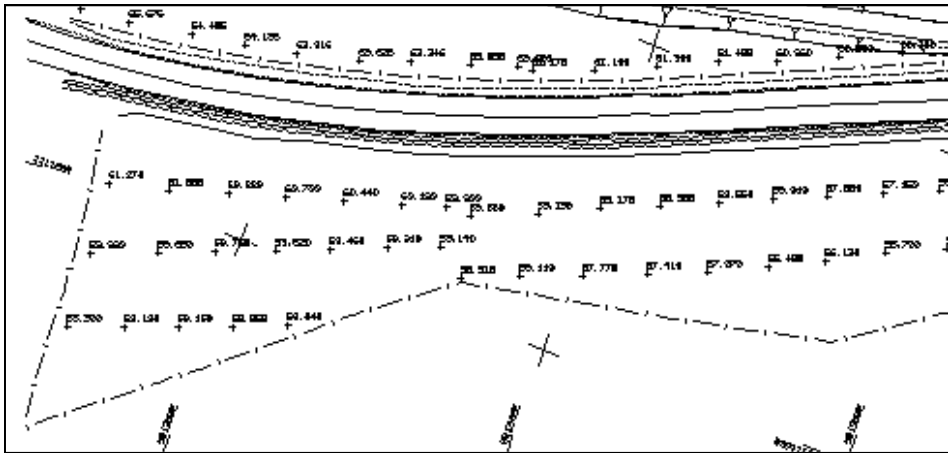
**Example 16 Production of comprehensive interpretation**

The following example combines a variety of alternatives to produce a useful working drawing.

```

DRAW, SIMPLE DESIGN GROUND
900, PLANDRAW
FD=' ', SC=500, GR=CROS, XG=50, YG=50, TC=BLUE, LC=GREE,
FR=FRAM, XL=501230, YL=111058, BE=340, DE=DETA
999
DRAW, SIMPLE DESIGN ROAD
900, PLANLINE
LC=RED, DE=DETA
999

```



**Figure 3 - 24 Drawing with comprehensive interpretation**

**Macro input data**

The above examples use both the PLANDRAW and PLANLINE macros. They may be altered or replaced completely if required. The macros may be reported by invoking the following commands. A set of MOSS minor options will also be generated which may be modified by the user if required.

```

MACRO
903, PLANDRAW, FILE
903, PLANDRAW, FILE
999

```

**Long section drawings**

Standard long section drawings may be produced by invoking the macro LONGDRAW and this will draw one string with associated chainage, distance and level annotation. However more than one profile often needs to be superimposed on the same drawing: a macro, LONGLINE, enables an additional long section string to be superimposed as necessary.

**Macro LONGDRAW**

**Example**

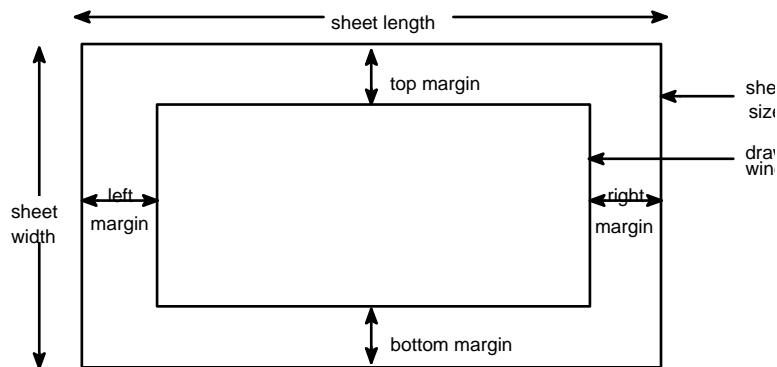
```
900 , LONGDRAW
HS=500 , VS=50 , LB=M001 , LR=M001
```

Attributes are assigned similarly to macro PLANDRAW and again if they are not relevant or of no interest then they may be ignored.

In the following

- PV implies any positive value
- NV implies any negative value
- CV implies any characters
- PF implies parameter file default.

**Input**

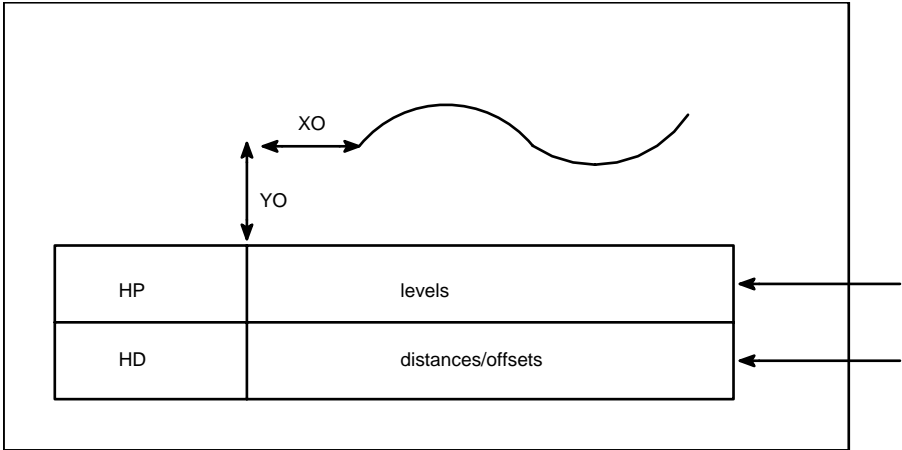


**Figure 3 - 25 Drawing sheet parameters**

Code	Description	Alternatives	Default
FD	First drawing if there is overplotting or if SL or SW are to be specified	"	-
OD	Subsequent drawing if there is overplotting	"	-
TR	Truncation or no truncation (of sheet area)	TRUN NOTR	PF
SL	Sheet length	PV	PF
SW	Sheet width	PV	PF
FR	Draw a frame Do not draw a frame	FRAM NOFR	PF

	Put registration marks on single sheet	REGR	
	Draw frame around windows	WIND	
ML	Left margin	PV	1.0
MB	Bottom margin	PV	1.0
MT	Top margin	PV	1.0
MR	Right margin	PV	1.0
PA	Paged or non-paged drawing	PAGE	PF
		NOPA	

◇ *If SL is assigned but not SW an A size sheet is specified.  
If SW is assigned but not SL a B size sheet is specified.*



**Figure 3 - 26 Long section drawing**

**Drawing details**

<b>Code</b>	<b>Description</b>	<b>Alternatives</b>	<b>Default</b>
XO	Offset to be added to the left of the leftmost point	PV	0.0
YO	Offset to be added to the lowest point	PV	0.0
AL	Absolute level datum	PV	-
LP	Box in which the level parameter is to be annotated	PV	1
LD	Box in which the distance parameter is to be annotated	PV	2
HP	Box description of the level parameter	C = chainage D = distance E = existing P = proposed L = level * = text coded at TP	P
TP	Box description if HP=*	CV	-
DP	Dimension of proposed parameter	CV	3
DD	Dimension of distance parameter	CV	4
SF	Ordinates, short or full	VF VS	VF

		HS	
		HF	
IN	Interval for ordinates and ordinate annotation Chainage interval for M strings Point sequence interval for general strings	PV -n for every nth point	every point every point
HD	Box description of the distance parameter	C = chainage D = distance E = existing P = proposed L = level * = text coded at TD	D
TD	Box description if HD=*	CV	-
HS	Horizontal scale	PV	
VS	Vertical scale	PV	
LC	String colour	CV	BLACK
DL	Dashed line indicator	" for dashed line	Solid
TC	Text colour	CV	BLACK
DT	Distance to top of section box	PV - distance from highest string point to top of window in model units NV - maximum level displayed	- -

Model details

Code	Description	Alternatives	Default
LR	Reference string	CV	
LB	Section string	CV	
XS	Start point on reference string (S.P.R.D.)	PV	First point
YS		PV	
XE	End point on reference string (S.P.R.D.)	PV	Last point
YE		PV	
LS	Length of section to be drawn per page	PV	-

- ◇ *FD and OD are normally used when producing composite drawings. The assignment FD=" indicates to the macro that this is the first drawing and OD=" indicates it is a subsequent drawing.*
- ◇ *The only essential variables which need to be assigned in the macro are HS, VS, LB and LR ie the horizontal and vertical scales, the string label being drawn and the reference string label.*
- ◇ *When superimposing long section profiles it may well occur that the first section is defined in LONGDRAW with the boxes being in positions 1 and 4 (say) with subsequent sections being defined with LONGLINE to infill positions 2 and 3. See example 19.*



## Macro LONGLINE

### Drawing details

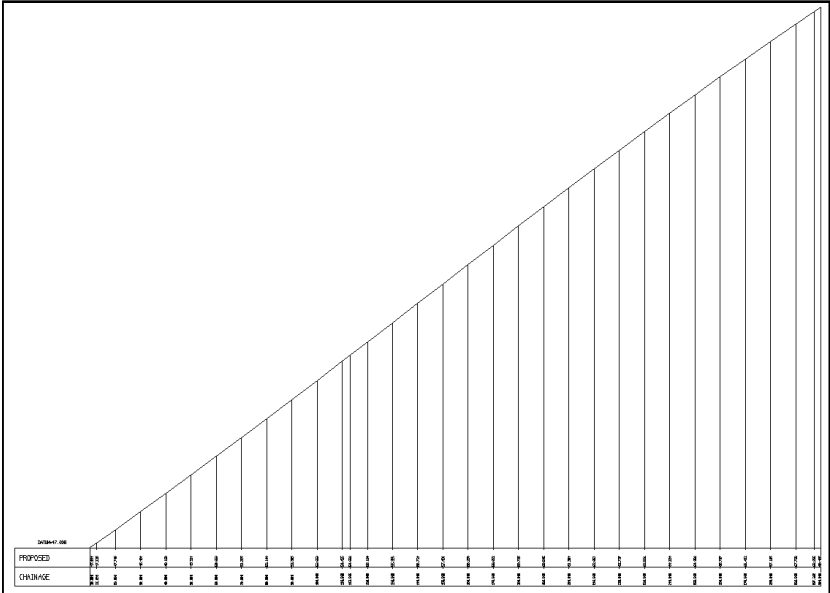
Code	Description	Alternatives	Default
LN	Box in which the 'level' parameter is to be annotated	PV	-
HN	Box description to the 'level' parameter	C = chainage D = distance E = existing P = proposed L = level * = text coded at TN	L
TN	Box description of HN=*	CV	-
LC	String colour	CV	BLACK
TC	Text colour	CV	BLACK
DL	Dashed line indicator	" for dashed line	Solid
IN	Interval indicator Chainage interval for M strings Point sequence interval for general strings	PV -n for every nth point	every point every point

### Model details

Code	Description	Alternatives	Default
LR	Reference string	CV	
LB	Label of string to be drawn	CV	
XS	Start point on reference string. (S.P.R.D.)	PV	First point
YS		PV	
XE	End point on reference string (S.P.R.D.)	PV	Last point
YE		PV	
DN	Dimension to be drawn		

**Example 17 Single long section profile**

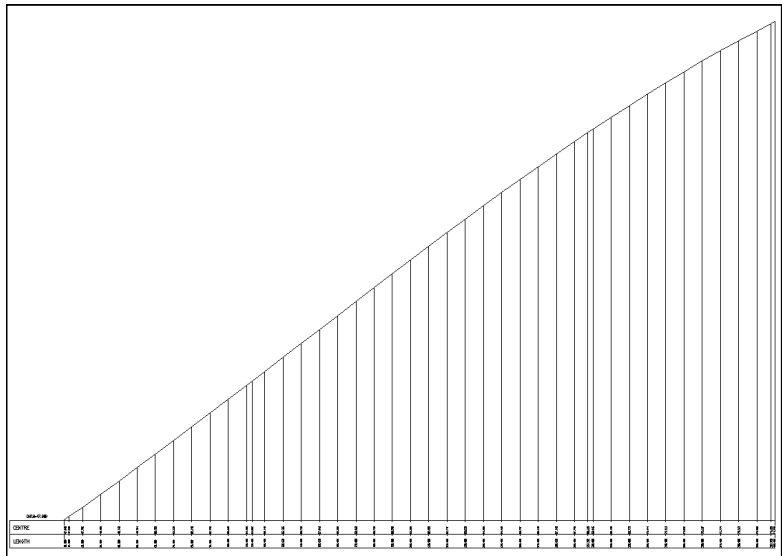
```
DRAW,SIMPLE DESIGN SECTIONS,SIMPLE DESIGN ROAD  
900, LONGDRAW  
HS=500, VS=50, LB=MAST, XE=300, LR=MAST  
999
```



**Figure 3 - 27 Single long section profile**

**Example 18 Single long section with different box annotation**

```
DRAW,SIMPLE DESIGN SECTIONS,SIMPLE DESIGN ROAD  
900, LONGDRAW  
HS=500, VS=50, LB=MST, HP=*, TP=CENTRE, HD=*, TD=LENGTH, LR=MAST  
999
```

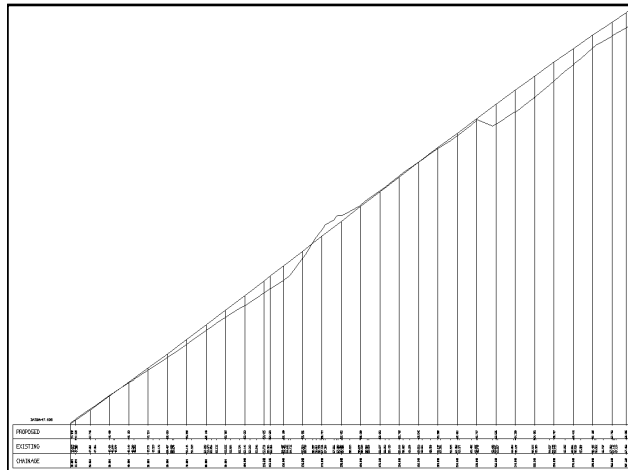


**Figure 3 - 28 Single long section profile with different box annotation**

**Example 19 Long section with existing section superimposed**

```

DRAW, SIMPLE DESIGN SECTIONS, SIMPLE DESIGN ROAD
900, LONGDRAW
HS=500, VS=50, LB=MAST, LD=3, LR=MAST, XS=10, XE=300
900, LONGLINE
LB=LSEC, LN=2, HN=E, LR=MAST
999
    
```



**Figure 3 - 29 Long section with existing section superimposed**

**Example 20 Multiple long section changing colours of strings**

This example is more complex, drawing a number of superimposed long sections. One of the sections curves back on itself, due to the string being a slip road that pulls away and passes under the 'proposed' string. To avoid confusion in matching the data with the appropriate point on the string, the string has been drawn in two parts (thus separating the data neatly)

```

DRAW, NEW THORNBROUGH SECTIONS, NEW THORNBROUGH
900, LONGDRAW
HS=2500, VS=250, LB=M003, LD=6, XS=4500, XE=5400, FR=FRAM, LR=M003
900, LONGLINE
LB=L SCT, LN=2, HN=E, LC='GREE', LR=M003
900, LONGLINE
LB=M002, YE=55, LN=3, HN=*, TN=' SOUTH SLIP', LC=RED, LR=M002
900, LONGLINE
LB=M002, YS=55, LN=4, HN=*, TN=' SOUTH SLIP', LC=RED, LR=M002
900, LONGLINE
LB=M001, LN=5, HN=*, TN=' NORTH SLIP ROAD', LC=BLUE, LR=M001
999
    
```

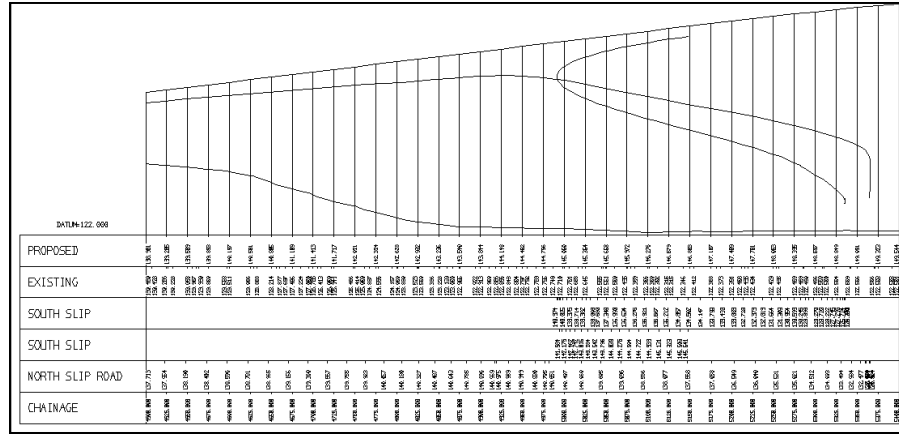


Figure 3 - 30 Multiple long sections changing colours of strings

**Macro input data**

All the above examples invoke macro LONGDRAW and LONGLINE. The macros may be reported by invoking the following commands. A set of minor options will also be generated which may be modified by the user if required.

```
MACRO  
903 , LONGDRAW , FILE  
903 , LONGLINE , FILE  
999
```

**Cross section drawings**

The drawing of pairs of section strings may still be undertaken using the CROSDRAW macro. However; to facilitate drawing one section string the SECTDRAW macro has been devised. Users are advised to use this in combination with the SECTLINE macro when drawing multiple section strings.

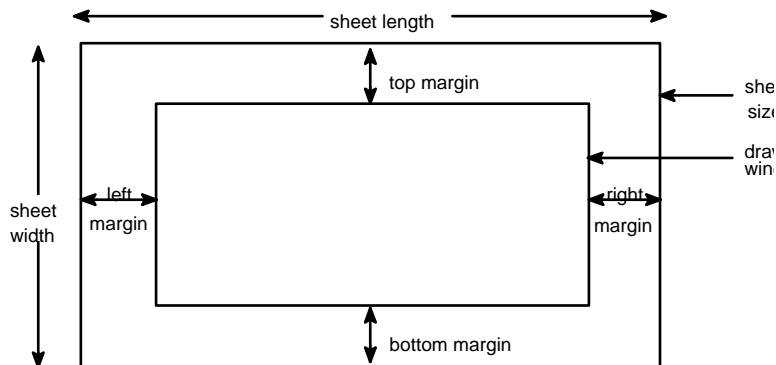
**Macro SECTDRAW**

**Example**

```
900 , SECTDRAW
UD=DLA, HS=500 , VS=500 , LB=M001 , SE=G
```

Attributes may be assigned but if they are not relevant or the default is appropriate they may be ignored.

In the following PV implies any positive value  
CV implies any characters



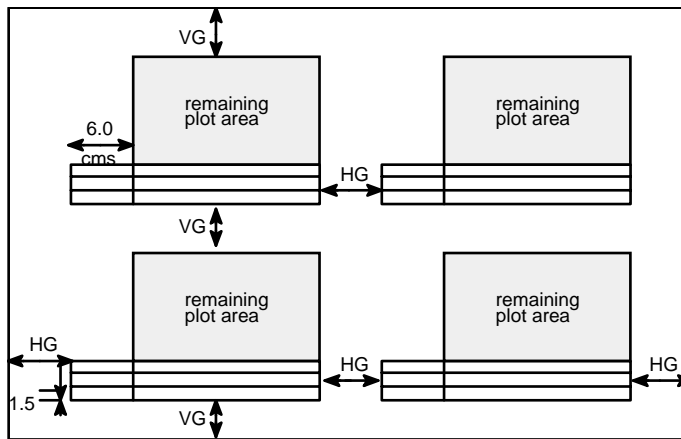
**Figure 3 - 31 Drawing sheet parameters**

**Sheet details**

Code	Description	Alternatives	Default
FD	First drawing if there is overplotting or if SL or SW are to be specified or if no truncation is required	"	-
OD	Subsequent drawing if there is overplotting	"	-
TR	Truncation or no truncation (of sheet area)	TRUN NOTR	PF
SL	Sheet length	PV	120
SW	Sheet width	PV	68
FR	Draw aframe Do not draw a frame Put registration marks on single sheet	FRAM NOFR REGR	PF

	Draw frame around windows	WIND	
ML	Left margin	PV	1.0
MB	Bottom margin	PV	1.0
MT	Top margin	PV	1.0
MR	Right margin	PV	1.0
PA	Paged or non-paged drawing	PAGE	PF
		NOPA	

◇ *If SL is assigned but not SW an A size sheet is specified.  
If SW is assigned but not SL a B size sheet is specified.*



**Figure 3 - 32 Drawing sheet - multiple cross section parameters**

Code	Description	Alternatives	Default
HS	Horizontal scale	PV	-
VS	Vertical scale	PV	-
AL	Code for absolute level datum	-	-
YO	Offset from lowest string point	PV	0.0
OL	Offset to be applied to left	CV	-
OR	Offset to be applied to right	CV	-
UD	Arrangement of sections A three character code where 1st character - U = sections drawn in ascending chainage up the window D = sections drawn in ascending chainage down the window 2nd character - L = Left justify sections in each column C = Centre justify sections in each column R = Right justify sections in each column 3rd character - A = Align each row of sections along a common base line S = Space the sections in each row according to the value in field 10.		UCS
HG	Horizontal gap between columns of sections	PV	1



VG	Vertical gap between rows of sections	PV	2
NR	Number of rows of sections per window	PV	-
NC	Number of columns of sections per window	PV	-
OF	Section width definition	ADD Displacement ABS Absolute units	ADD
SF	Ordinates, short or full	VF VS HF HS	VF
LE	Box in which the 'existing' level parameter is to be annotated	PV	
LD	Box in which the 'distance' /offset parameter is to be annotated	PV	2
HE	Box description of the 'existing' parameter	C = chainage D = distance E = existing P = proposed L = level * = text coded in TE	E
TE	Box description if HE=*	CV	-
TE HD	Box description of the 'distance' parameter	C = chainage D = distance E = existing P = proposed L = level * = text coded in TD	D
TD	Box description if HD=*	CV	
LC	String colour	CV	BLACK
TC	Text colour	CV	BLACK
DL	Dashed line indicator	" for dashed line	Solid
LB	Reference string on which sections are based	CV	
XS YS	Start point on reference string (S.P.R.D.)	PV	First point
XE YE	End point on reference string (S.P.R.D.)	PV	Last point
SE	Initial character of sections set		
IN	Interval at which sections are needed.	PV	

- ◇ *AL and YO should not be coded together*
- ◇ *If OF=ADD, OL and OR should be positive.  
If OF=ABS, OL and OR should be negative when left of the reference string and positive when right of the reference string.*

- ◇ *If LB is a master alignment code IN as positive value. If LB is a non-master code IN=-ve value (see minor option 804)*
- ◇ *The mandatory data for this macro is HS, VS, LB and SE; the horizontal scale, vertical scale, reference string label and the initial character of the section set.*

## Macro SECTLINE

### Drawing details

Code	Description	Alternatives	Default
LN	Box in which the 'level' parameter is to be annotated	PV	2
HN	Box description of the 'level' parameter	C = chainage D = distance E = existing P = proposed L = level * = text coded at TN	L
TN	Box description if HN=*	CV	-
LC	String colour	CV	BLACK
TC	Text colour	CV	BLACK
DL	Dashed line indicator	" for dashed line	SOLID
EO	Extra ordinate indicator	" for extra ordinates and annotation	-
SF	Ordinate short or full (only applies if EO=" coded)	VF VS HF HS	VS

- ◇ *The EO annotation is added to the offset annotation box created by SECTDRAW and may cause a certain amount of clutter.*

### Model details

Code	Description	Alternatives	Default
SN	Initial character of sections to be drawn	CV	
XS	Start point on reference string (LB in	PV	First point
YS	CROSDRAW) (S.P.R.D.)	PV	
XE	End point on reference string (S.P.R.D.)	PV	Last point
YE			
DN	Dimension to be annotated (see minor option 846 for details of permitted values)		3

- ◇ *The mandatory data for this macro is SN, the initial character of the section set to be drawn. However, if LN (the box number to be used) is left blank to default to 2, then the initial SECTDRAW command must have LD assigned to something other than 2.*

### Example 21 Simple set of cross sections

```

DRAW, SIMPLE DESIGN SECTIONS, SIMPLE DESIGN ROAD
900, SECTDRAW
LB=MAST, XS=100, XE=300, IN=20, HS=100, VS=50, LD=3, SE=R, HE=P
900, SECTLINE
HN=E, SN=G, XS=100, XE=300
999
    
```



Figure 3 - 33 Simple set of cross sections

### Example 22 Define positioning of sections on the page

In this example cross sections are drawn on an A1 sheet, justified to their right hand edges, and aligned vertically. (In example 21 the sections were positioned by the default: centre justification and vertical spacing equal to the vertical gap).

```

DRAW, SIMPLE DESIGN SECTIONS, SIMPLE DESIGN ROAD
900, SECTDRAW
FD=' ', SL=1, LB=MAST, XS=100, XE=300, IN=20, HS=100, VS=50, LD=3, SE=R,
NR=3, HG=2, NC=7, VG=1, TR=NOTR, HE=P, UD=URA
900, SECTLINE
HN=E, SN=G, XS=100, XE=300
999
    
```



Figure 3 - 34 Set of sections positioned on page

### Example 23 Set of sections changing the box titles

In this example, the 'Distance' box is renamed as 'Offset' and placed in box number 3. Box number 1 has had its title changed to 'Road', and box number 2 to 'Ground'.

```

DRAW, SIMPLE DESIGN SECTIONS, SIMPLE DESIGN ROAD
900, SECTDRAW
LB=MAST, XS=100, XE=300, IN=20, HS=100, VS=50, LD=3, SE=R,
HE=*, TE=ROAD, HD=*, TD=OFFSET
900, SECTLINE
HN=*, TN=GROUND, SN=G, XS=100, XE=300
999
    
```

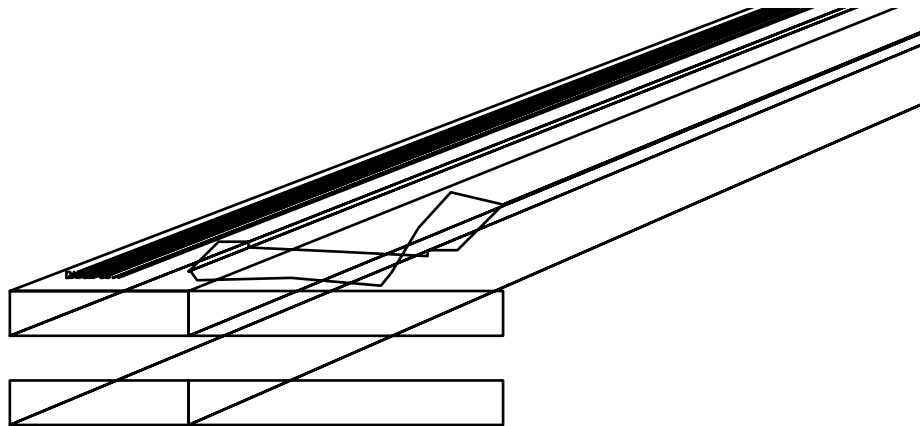


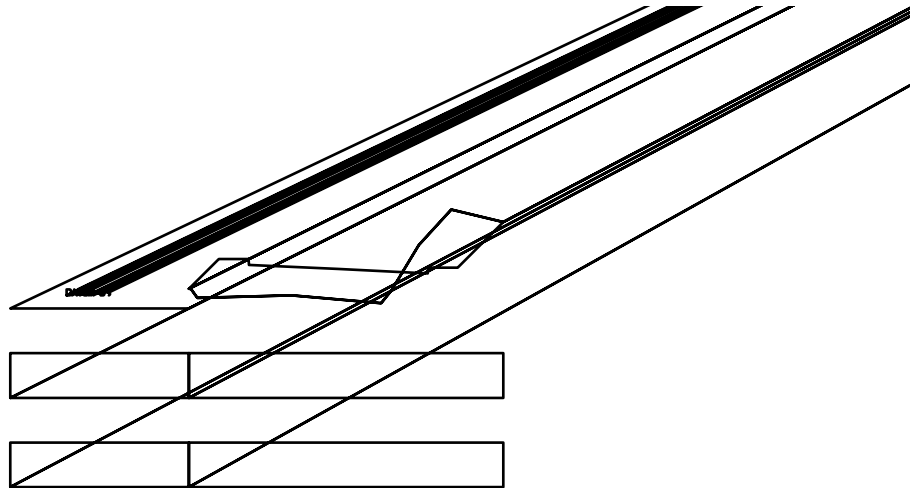
Figure 3 - 35 Set of sections changing box titles

### Example 24 Add extra offset annotation

Here a fourth box of annotation is created. It contains the fourth dimension of the section string (the offset).

```

DRAW, SIMPLE DESIGN SECTIONS, SIMPLE DESIGN ROAD
900, SECTDRAW
LB=MAST, XS=100, XE=300, IN=20, HS=100, VS=50, LD=4, SE=R, HE=P, LE=2
900, SECTLINE
HN=E, SN=G, XS=100, XE=300, LN=1
900, SECTLINE
HN=*, TN='OFFSET G', SN=G, DN=4, XS=100, XE=300, LN=3
999
    
```



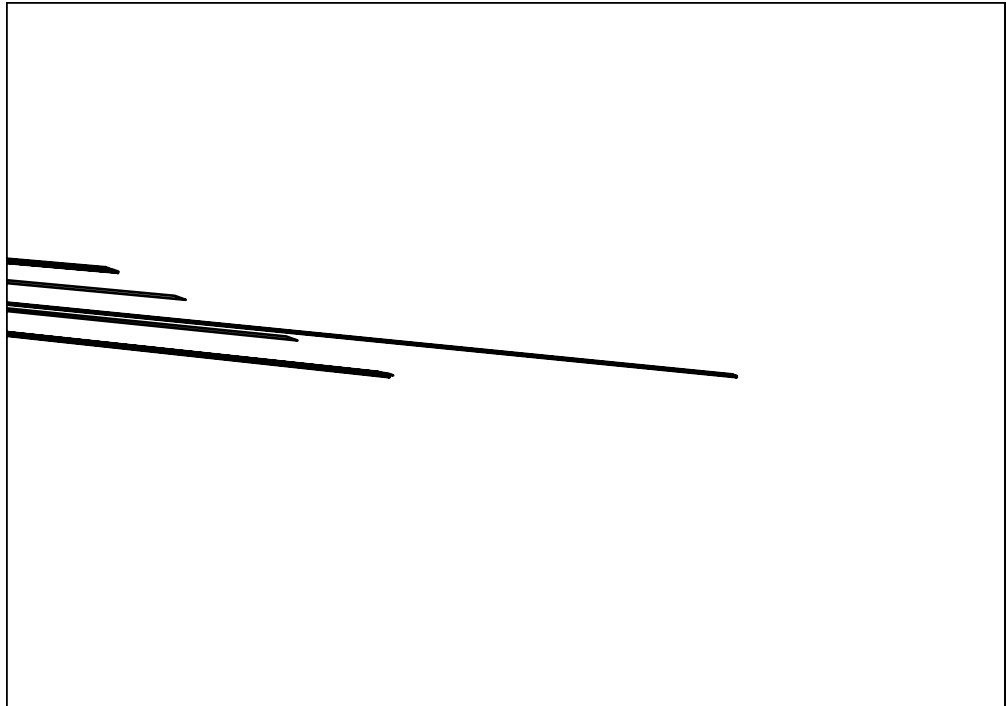
**Figure 3 - 36 Set of cross sections adding extra offset annotation**

### Example 25 Simple composite drawing

By varying the values of the margins (ML,MT, MR, MB) individual drawings may be positioned within the drawing area. By simply requesting overplotting both drawings may be positioned within the same drawing area. It should be noted that the drawings considered may be either plans, long or cross sections, perspectives or any combination of these.

```

DRAW, SIMPLE DESIGN ROAD
900, PLANDRAW
FD= ' ', FR=FRAM, ML=8, MB=28, MT=4, MR=8, TR=NOTR,
SC=500, XL=501230, YL=111058, BE=340, XG=50, YG=50, DE=DETA
999
DRAW, SIMPLE DESIGN SECTIONS, SIMPLE DESIGN ROAD
900, LONGDRAW
OD= ' ', ML=6, MB=2, MR=6, MT=34, LP=2, LD=3,
HS=500, VS=250, LB=MAST, XS=100, XE=300, LR=MAST
900, LONGLINE
LN=1, HN=E, LB=LSEC, LR=MAST
999
    
```



**Figure 3 - 37 Example - Simple composite drawing**

### Example 26 Composite drawing

```

MOSS
DRAW,NEW THORNBROUGH
019,G,4=-1
019, TI,4=-1
019,BDRY,4=-1
019,I009,4=-1
019,I010,4=-1
019,I011,4=-1
019,I012,4=-1
019,I014,4=-1
019,I017,4=-1
019,I018,4=-1
019,I030,4=-1
019,0,4=-1
019,4=+1
900,PLANDRAW
FD='',SC=2500,XL=2750,YL=30350,BE=60,DE=DETA,SL=119,SW=84,
ML=6,MB=8,MR=70,MT=42,FR=FRAM,TR=NOTR,IN=100
019
019,G,4=-1
019,I009,4=1
019,I010,4=1
019,I011,4=1
019,I012,4=1
019,I014,4=1
019,I017,4=1
019,I018,4=1
019,I030,4=1
019,4=-1
810,DASH,5=2,0.2,,0.2,0.2
825
019
019,G,4=-1
019,0,4=+1
019,4=-1
810
821,WIND
825
999
DRAW,NEW THORNBROUGH VIEW
019,MI,4=1
019,V,4=1
019,I,4=1
019,E,4=1
019,4=-1
900,PLANDRAW
SC=0.35,TI=TITL*,ML=53,MB=8,MR=26,MT=42,XL=1.92,YL=1.95,OD='',
GR=NOGR,FR=WIND,XG='',YG=''
019
019,G,4=-1
019,MI,4=-1
019,V,4=-1
019,I,4=-1
019,E,4=-1
019,4=+1
825,2=DETA
999
DRAW,NEW THORNBROUGH SECTIONS,NEW THORNBROUGH

```

```

019,G,4=-1
900, LONGDRAW
OD=' ', ML=6, MB=46, MR=70, MT=6,
HS=3000, VS=300, LB=M003, LD=5, XS=4500, XE=5400, LR=M003, FR=WIND
900, LONGLINE
LR=M002, LB=M002, YS=9, YE=55, LN=2, HN=*, TN=' SOUTH SLIP'
900, LONGLINE
LR=M002, LB=M002, YS=55, LN=3, HN=*, TN=' SOUTH SLIP'
900, LONGLINE
LR=M001, LB=M001, YS=9, LN=4, HN=*, TN=' NORTH SLIP'
900, SECTDRAW
ML=53, MB=46, MR=26, MT=6, HS=750, VS=750, LB=M003, XS=4400, XE=4500,
SE=R, FR=WIND, UD=D, NR=2, NC=1, HG=2, VG=2, HD=*, TD=OFFSET,
LD=3, OF=ABS, OL=-80, OR=65
900, SECTLINE
LN=2, SN=X, LB=M003, XS=4400, XE=4500, DL=' '
999
    
```

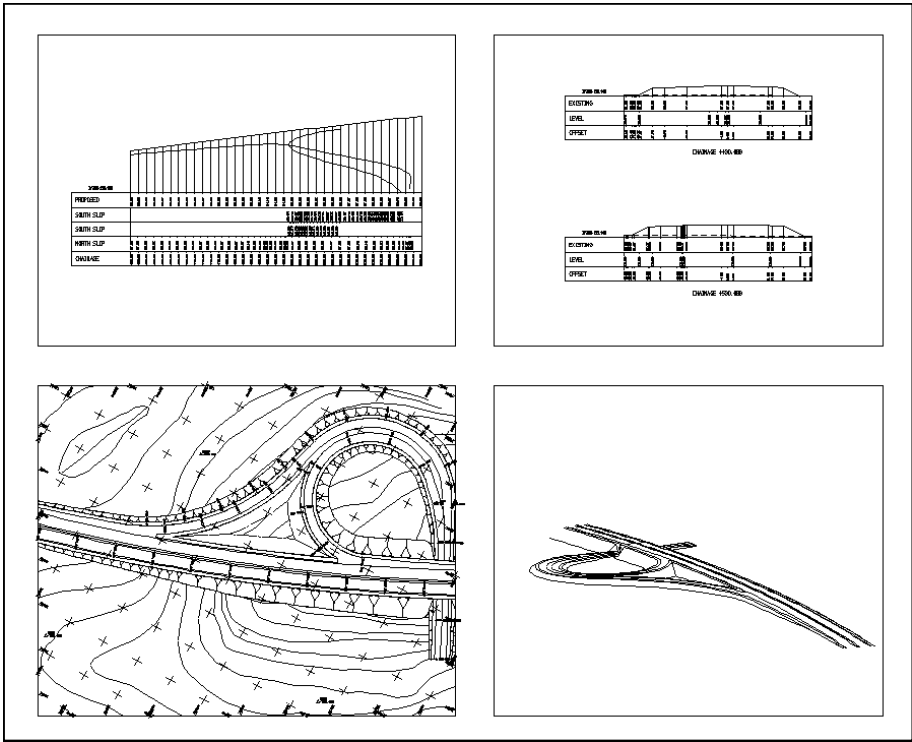


Figure 3 - 38 Example - composite drawing

Macro SURVDRAW

This macro contains DRAW minor options which invoke various macro symbols, line styles and detail interpretation at 1/500 scale. If you wish to draw at some other scale you should rerun the macro input with altered symbol sizes etc.

Level strings are omitted by default but if required they may be drawn; as spot levels only.



A north point macro symbol will also be plotted if you edit into the model a point string with label prefix PNT where the symbol should appear.

**Example**

```
900 , SURVDRAW
SC=500
```

This macro is based on PLANDRAW. For a full explanation of the parameters used see the PLANDRAW documentation.

Attributes may be assigned but if they are not relevant or the default is appropriate they may be ignored.

**Input data**

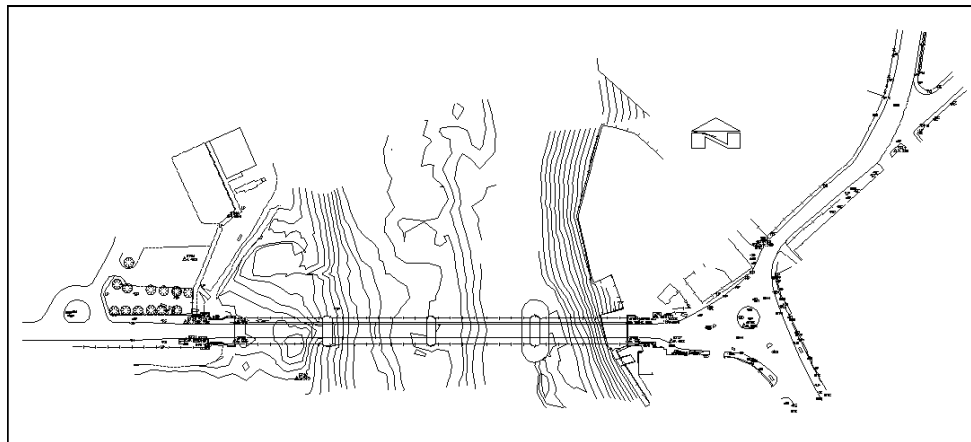
Code	Description	Alternatives	Default
FD	First drawing if there is overplotting or if SL or SW are to be specified	"	-
OD	Subsequent drawing if there is overplotting	"	-
PA	Paged or non-paged drawing	PAGE NOPA	PF
TR	Truncation or no truncation (of sheet area)	TRUN NOTR	PF
SL	Sheet length	PV	PF
SW	Sheet width	PV	PF
FR	Draw a frame Do not draw a frame Put registration marks on sheet edge Draw frame around windows	FRAM NOFR REGR WIND	PF
ML	Left margin	PV	1.0
MB	Bottom margin	PV	1.0
MT	Top margin	PV	1.0
MR	Right margin	PV	1.0
SC	Scale	PV	-
XL	Relationship of model to drawing window.	PV	
YL	Coordinates of bottom left point and bearing of left hand side	PV	
BE		PV	
LC	String colour	CV	BLACK
TC	Text colour	CV	BLACK
GR	Grid with edge ticks Grid with crosses at intersections Full line grid Do not draw a grid	EDGE CROS FULL NOGR	NOGR
XG	X spacing interval of grid	PV	50
YG	Y spacing interval of grid	PV	50
IO	Plot inside or outside a boundary	IN OUT	-
BD	Boundary string label if IO=IN or IO=OUT	CV	-
XB	Minimum model coordinate restricting region to be drawn	PV	0.0
YB		PV	0.0
XT	Maximum model coordinates restricting	PV	99999999.9

YT	region to be drawn	PV	99999999.9
LE	Spot levels required	"	-
AN	Rotation of north point from left hand side		90 (angle in degrees)

- ◇ *If SL is assigned but not SW an A size sheet is specified  
If SW is assigned but not SL a B size sheet is specified*

### Example 27 Survey drawing

```
DRAW, NORFDECK DGM
900, SURVDRAW
SL=1, TR=NOTR, SC=500, XL=865, YL=960
999
```



**Figure 3 - 39 Example - survey drawing**

The macros may be reported by invoking the following commands. A set of minor options will also be generated which may be modified by the user if required.

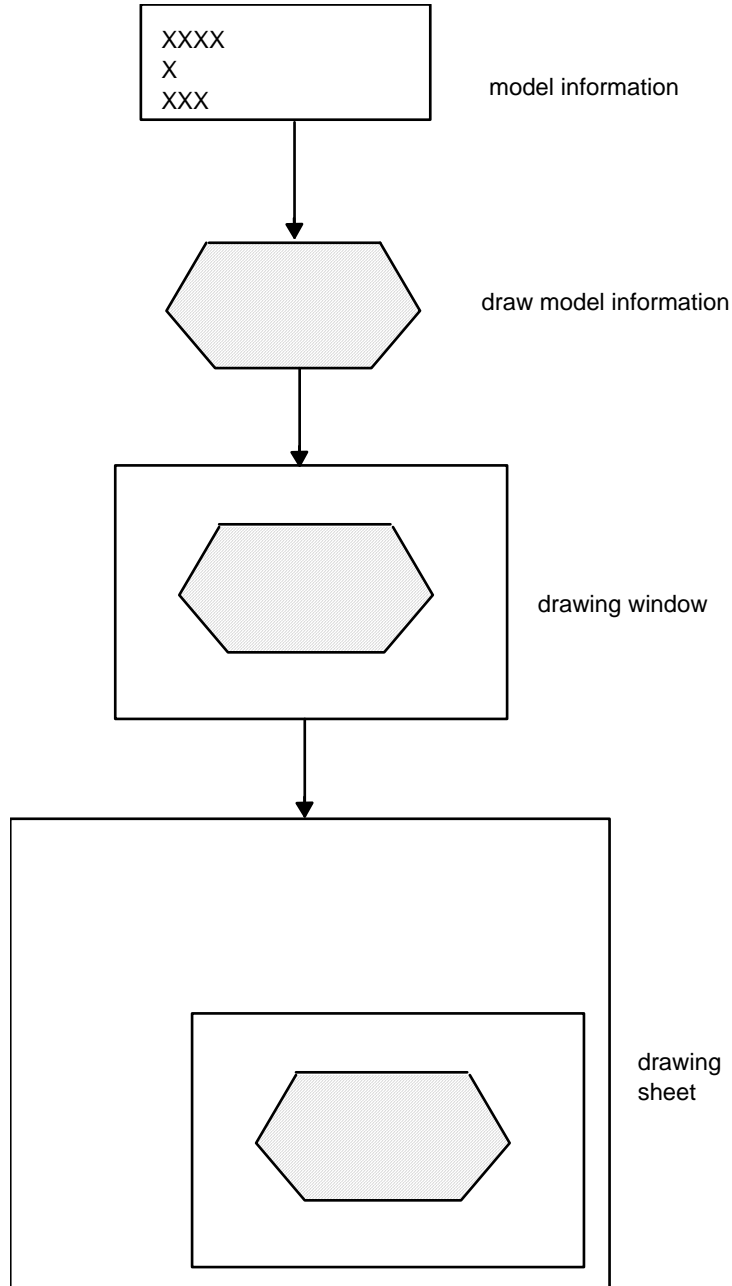
```
MACRO
903, SURVDRAW, FILE
999
```

# Drawing concepts

## Model to drawing transformation

A drawing is produced by transferring information from a model or group of models into a picture file which may then be displayed either on a graphics terminal or on a plotter. The ability to define precisely the source of the information and similarly to define precisely the form of the output is essential. The latter requirement includes specifying the drawing sheet and material and the former includes referencing the part or parts of models of interest.

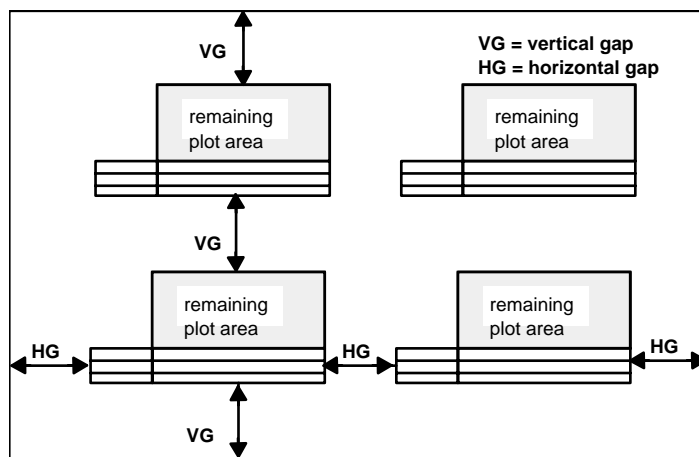
The highest level of a drawing may be thought of as one drawing sheet of infinite size including everything in a model or group of models to produce a picture. However the picture once produced may then be broken into manageable subpictures or 'windows' and these windows may be arranged on the drawing sheet.



**Figure 3 - 40 Model - drawing relationship**

If the margins are not defined or are defined as zero the drawing window is coincident with the drawing sheet.

The production of Plan and Long section drawings is adequately catered for by this arrangement but for cross sections each section, from a set of sections related to any one base may be thought of as being a separate subpicture or window. Information is needed, dictating the spacings between sections, both horizontally and vertically. Additionally the order of the sections, increasing chainage UP/DOWN each column, and the frequency of columns and rows on the drawing sheets has to be defined.



**Figure 3 - 41 Drawing sheet - showing multiple cross sections**

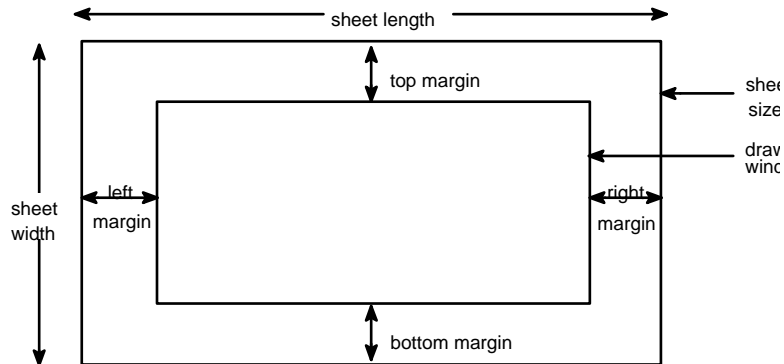
Having decided on the layout of the drawing, the relationship is required between the coordinate system of the model and the coordinate system of the picture by reference to the bottom left hand corner of the drawing window and by defining scaling, translation and rotation. The two coordinate systems are known as the MODEL COORDINATE SYSTEM and the DRAWING COORDINATE SYSTEM and their mapping relationship is defined with minor option 803.

Minor options 800-803 fully define the transfer conditions between the stored model information and the drawing.

Minor option 800 specifies the size of the drawing sheet whilst minor option 802 specifies the position of the 'window' within the sheet. The 'window' is that region or area of the drawing sheet within which information can be drawn. Option 803 relates the model information to the drawing window by invoking scaling and transformations. Although option 800 gives the drawing sheet parameters for any particular model, there are occasions when information from one or more than one model needs to be included either in the same subpicture (over plotting) or on the same drawing sheet (composites). This last function is accomplished using minor option 801.

Whilst the drawing sheet may be simply defined in terms of material type, and sheet length and width, standard A or B sheets may also be requested a further facility, appropriate to some printing processes allows for mirror imaging and localised scaling.

The window on the drawing sheet within which there may be drawing is restricted by positioning a 'WINDOW' by reference to the margins between the window sides and the sheet boundaries.

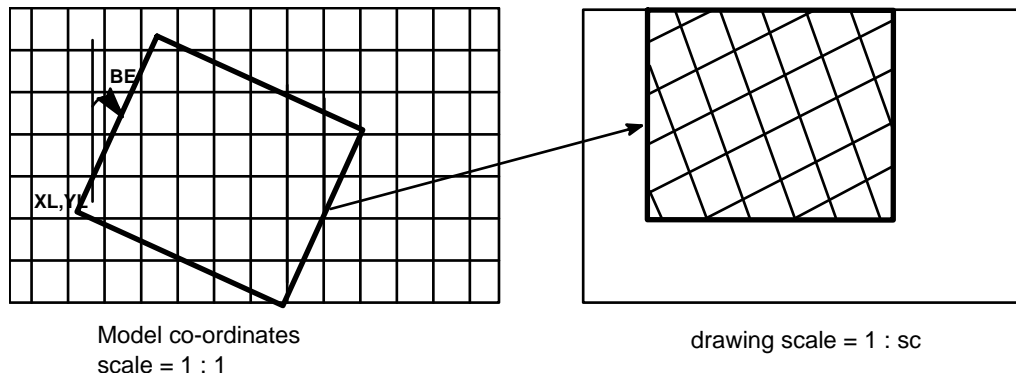


**Figure 3 - 42 Drawing sheet parameters**

It is at this stage that differences between plan and section drawings first emerge. For PLAN drawings the drawing coordinate system (x,y) relates to the model coordinates (X,Y) whilst for LONG or CROSS section drawings it relates to the model coordinates (D,Z) (where D is distance or offset measurement and Z is any defined dimension, usually an elevation).

**Plan drawings**

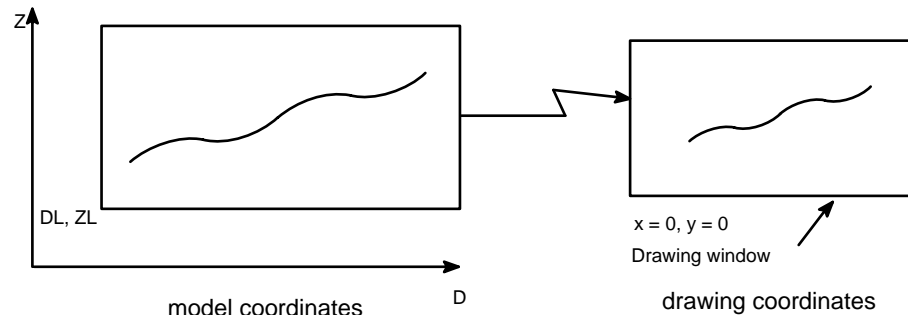
First the origin of the drawing window ( $x = 0, y = 0$ ) is defined in the model coordinate system (XL,YL). Then the drawing window is rotated about the origin in a clockwise direction, and finally a scale factor is defined.



**Figure 3 - 43 Plan drawing showing scale and rotation**

**Long section drawings**

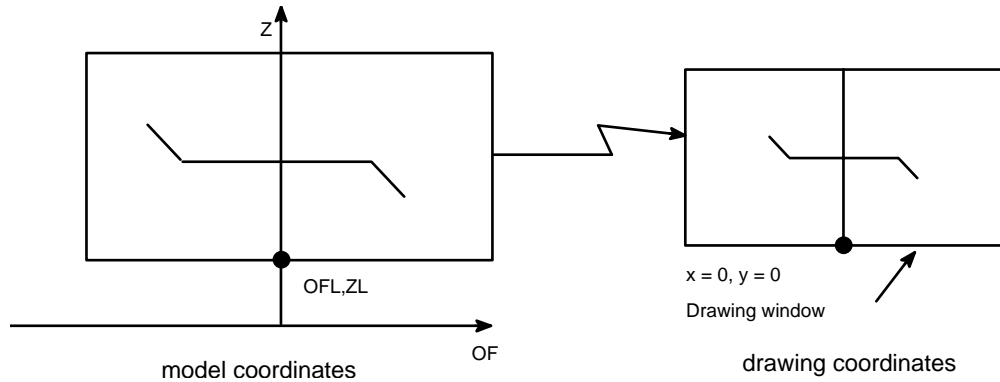
For a long section the model coordinate system is (D,Z) where D is the distance along the section string relative to its start and Z is usually the absolute height or elevation. The longitudinal axis may be either a straight line defined in plan by a pair of (X,Y) coordinates or any string. All other strings to be drawn are then projected on to this axis.



**Figure 3 - 44 Long section drawing showing model and drawing coordinates**

Cross section drawings

The model coordinate system for cross sections is (OF<Z) where OF is the offset relative to the datum line or string that was used to generate the section and Z is the absolute level.



**Figure 3 - 45 Cross section drawing showing model and drawing coordinates**

In this instance it will be noticed that the drawing coordinate origin ( $x = 0, y = 0$ ) is not based initially on the bottom left corner of the window. The pivot point shown is used until all sections are complete and the window is the 'floated' on the drawing sheet until the spacing criteria (see option 802) are met.

Paging

In the production of PLAN drawings there is a potential conflict between the amount of model information to be drawn and the amount of space within the window where it is to be drawn relative to the scaling parameters assigned. The extent of the model information being mapped from the model into the drawing window may not exactly match the size of the window allocated to receive it. The window may be too large or conversely too small.

If the window of the drawing is too large the user may wish to truncate the window both at the top and also at the right hand side, and this has advantages if the window and drawing sheet are coincident, since the drawing sheet also will then be effectively truncated.



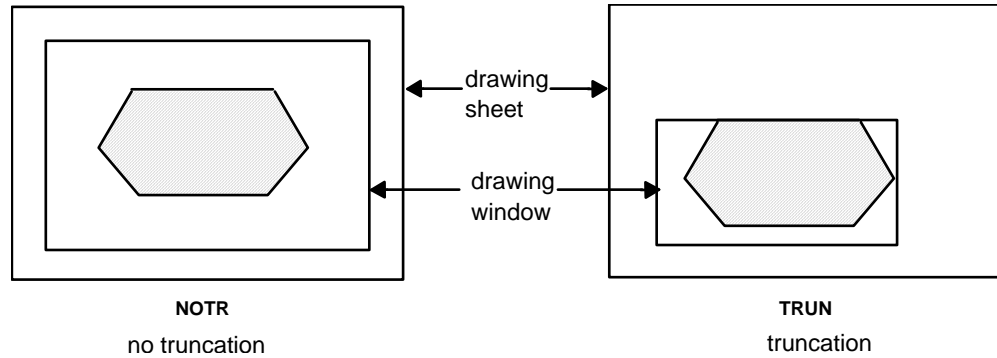


Figure 3 - 46 Paging - truncation

The user may wish to ensure that the window is not truncated since subsequent drawing commands may need to draw in the currently blank area.

The other alternative is that the window available on the drawing sheet is too small for the information to be drawn, and to cater for this the user may wish to either generate a mosaic of windows covering all the information or simply to accommodate the first window only. The elements of the mosaic are known as "PAGES".

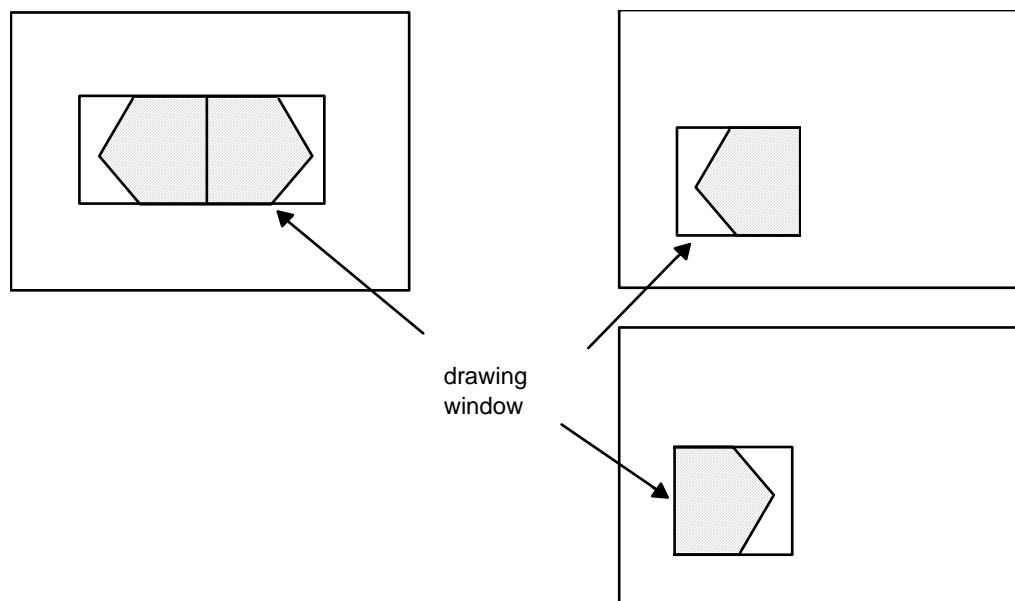


Figure 3 - 47 Paging - mosaic

The user may wish to ensure that the window is not truncated since subsequent drawing commands may need to draw in the currently blank area.

Each page of the mosaic will be drawn on a separate drawing sheet in the same 'window' position on each sheet. There is no facility whereby a drawing can be paged automatically with both pages on the same drawing sheet.

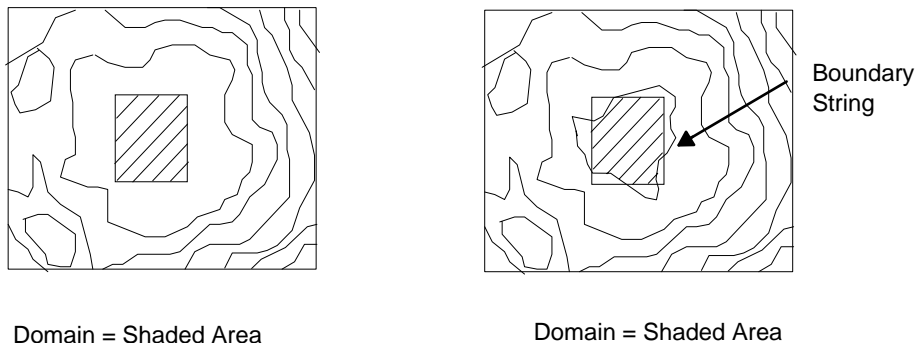
◇ *Long section drawings may be paged only with respect to length.*

The drawing of an individual cross section cannot be paged but depending on the spacings between 'section objects' defined by the user, paging is automatically invoked for groups of cross sections.

**Selection of model content**

Once the relationship between the model and the drawing has been established the actual content of the drawing is then selected, and the first step towards this is to specify the 'domain' of the model. The simplest interpretation of the domain is that of a region of the model that can be selected in a variety of ways.

**Plan drawings**

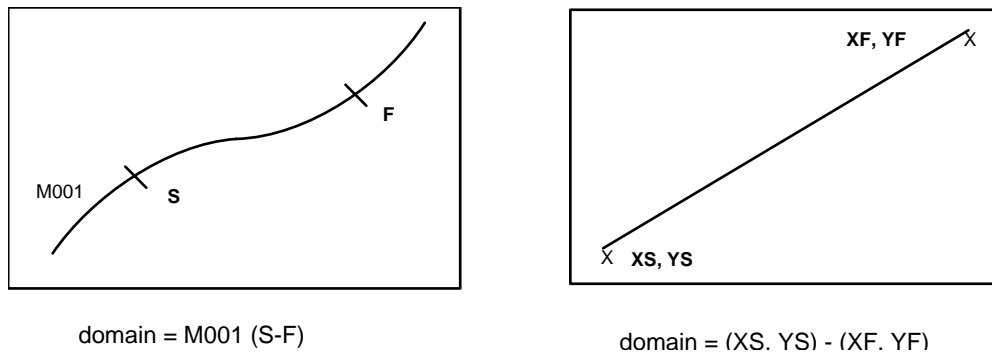


**Figure 3 - 48 Plan drawing - domain**

The domain may be defined by minimum and maximum model coordinates or by a boundary string (either inside or outside), or by a combination of the boundary string and minimum and maximum coordinates.

**Long section drawings**

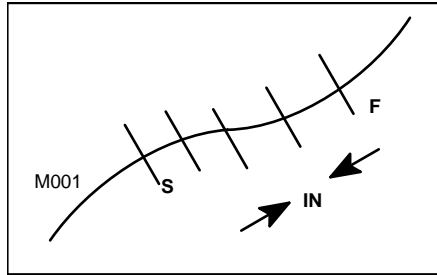
Long Section Drawings are based either on a reference string or on a base line. This defines the horizontal domain whilst the vertical domain may be based either on the reference string or on an absolute datum level.



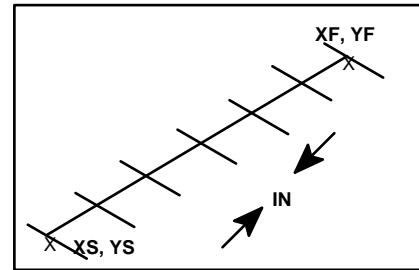
**Figure 3 - 49 Long section - domain**

**Cross section drawings**

The reference line upon which the cross sections are based provide the domain specification for cross section drawings. This reference could be a reference string or a base line.



domain defined by M001 (S-F);  
interval IN



domain defined by (XS,YS)-(XF,YF);  
interval IN

**Figure 3 - 50 Cross section - domain**

The cross section domain is further qualified by the extent of interest to either side of the reference point. This extent may be an absolute offset or an additive constant to be added to the existing extremity of each section. Any information lying outside the domain is considered to be of no value to the drawing and is therefore ignored. This does not mean however that all information within the domain need be drawn. Minor option 804 does not define what has to be drawn but it restricts and references the part of the model under consideration.

**Selection of drawing environment**

Pictures are built up by drawing blocks of information, and associated with each block are environment attributes which describe the actual appearance of the block. For example a block may consist of a contour with height embedded within it with a defined character height. Attributes, once set, often retain the same values for different blocks of information. For instance once a suitable character height is chosen it may be retained for string labels, point, and axis annotation, even though the colours may have been changed. A typical series of instructions would be :-

- Draw Strings A - E in default line colour and style.
- Change Line Colour to Blue.
- Draw Strings F - H.
- Change Line Style to Dashed Lines.
- Change Text colour to Red.
- Draw Grid and associated annotation.

The environment attributes are controlled by minor options 805 - 812 as follows:-

805	Pen type and colour for lines.
806	Pen type and colour for text.
808	Text font, style and size.
810	Line style.
812	Curve fitting style.

At any point in the production of a drawing the options can be used to change the drawing environment and the reset values will remain in force until modified or reset to the installation defaults.

## Curve fitting

The last environment option is curve fitting of which there are two styles available.

1. MOSS style curve fitting.
2. SPLINE style curve fitting.

MOSS style curve fitting is the style used throughout the MOSS system in designing, generating and editing strings. The theory is based on circular arcs. Between any two points the radius can vary. Thus if the radius at one end of a link is R1 and the radius at the other is R2 then the curve fitted through any intermediate position has a radius which linearly varies and passes through both end points. The features of the algorithm used are:-

- both end points have 6D status calculated (ie bearing and radius). For 3D strings this may automatically be carried out.
- throughout a string those links which are exactly circular arcs or straights are correctly simulated whilst transitions are closely approximated.
- throughout any curve fit string there is continuity of both bearing and curvature.

Local SPLINE curve fitting fits a cubic equation  $y = ax^3 + bx^2 + cx + d$  passing through two successive points on a string. Each curve has continuity of bearing at each point between the approaching curve and the following. Properties of this algorithm are:-

- circular arcs, straights and transitions are closely but not precisely generated.
- throughout the string there is continuity of bearing but not of curvature.
- the 'SPLINE' curves tend to be flatter than 'MOSS' curves.
- applying spline curves to contours will usually give smooth non-crossing curves.

The approach adopted in both styles of curve fitting is to derive the appropriate curve and then calculate the number of points to be added between the end points of the link to ensure the chord to arc distance is smaller than a tolerance. These additional points are interpolated so that linear plotting may be carried out to simulate the curve.

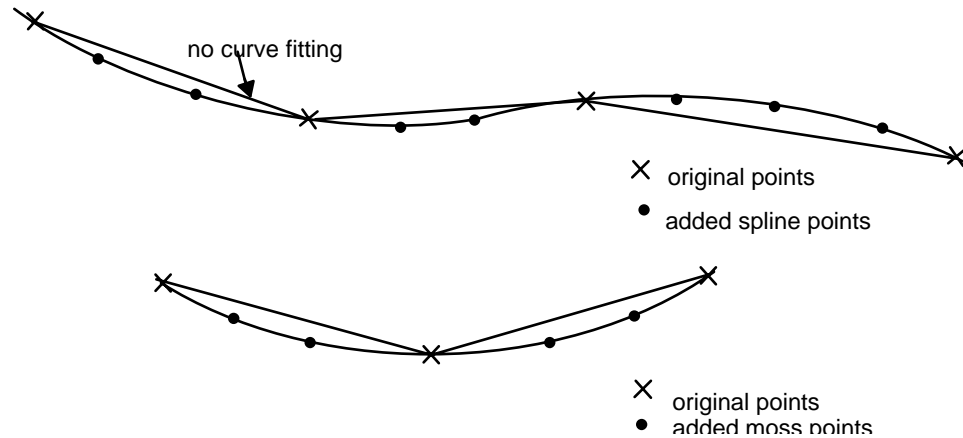


Figure 3 - 51 Example SPLINE and MOSS style curve fitting

### Object and element referencing

Within any drawing there are often natural groupings of drawn entities, which may include strings, annotation, enhancement boxes etc. Drawing symbols for north signs, or boxed annotation giving curve details are two examples which fall in to this category. Although initially positioned on the drawing by the DRAW minor options, the interactive graphics facility may be invoked by the user to reposition the whole 'OBJECT' as it is called. The components of each object are referred to as 'ELEMENTS' since they need not necessarily be strings.

Examples of objects without strings include frames, grids and titles, whilst objects may contain both strings and non-string details such as cross sections and their associated annotation.

An 'object' is initialised by assigning a name to it via minor option 814. All subsequent minor option commands are linked to the object until it is closed by option 815. Between the enclosing opening and closing commands component 'element labels' may be defined.

For example:

```
814,3=OBJ1
805,RED
810,DASH,5=0.2,0.2,0.0,0.2,0.2
826,STR1
826,STR2
805,GREEN
810
822,CROS,3=GRID
815
```

It is important to note that at any one time only one object may be opened. Subsequently elements may be deleted, or moved from objects.

Defining a series of objects within DRAW input data can be particularly useful when manipulating a drawing within graphics. Defining different sets

of strings to belong to a table of objects it allows you to make objects visible or invisible at will and prevent the drawing appearing cluttered.

It is advantageous to set up objects in your DRAW input data if the drawing is to be passed to a drafting system via 2DDXF as these objects will dictate the layering.

### **Frames and grids**

The framing option provides a flexible way of outlining drawings. The whole sheet boundary may be drawn, which is of value if a continuous plotting material is the plotting medium and the drawing sheet is to be cut from it. Similarly the drawing window may be outlined to give a definite border. Some users may find it convenient to use a combination of the window definition (802) and the framing option (821) to produce a complete outlining of the drawing sheet.

It is not necessary to frame the sheet boundary of, for example, an A0 drawing if a physical A0 sheet will be used in the production of a drawing.

The option also provides for the drawing of register marks slightly offset from each of the four corners of the drawing sheet. This is useful for registration of successive layers of information, particularly where final drawings are produced by multicolour offset lithography or a similar process.

The gridding option (822) draws a grid within the current window in the current line style and colour. In the case of long and cross sections the grid is drawn in the drawing area of each 'section object'. 'Section objects' are described under 'Axes and axis annotation for sections drawings'.

The grid may be left undrawn or conversely multigridding can be carried out by repeatedly changing the grid spacing and/or the current linestyle and colour.

### **Drawing strings**

The main component of a MOSS drawing will be the drawing of the strings in a variety of colours and linestyles. Although many of the attributes are individually allocated and then drawn with minor option 826 there is, with minor option 825, a shorthand way of drawing strings with all the standard interpretation in one command. Similarly option 830 is specifically intended for the output of text strings.

### Axes and axis annotation for section drawings

A unique feature within major option DRAW is the flexibility of producing section annotation. A sample set of four different styles of section is shown in Figure 3 - 52.

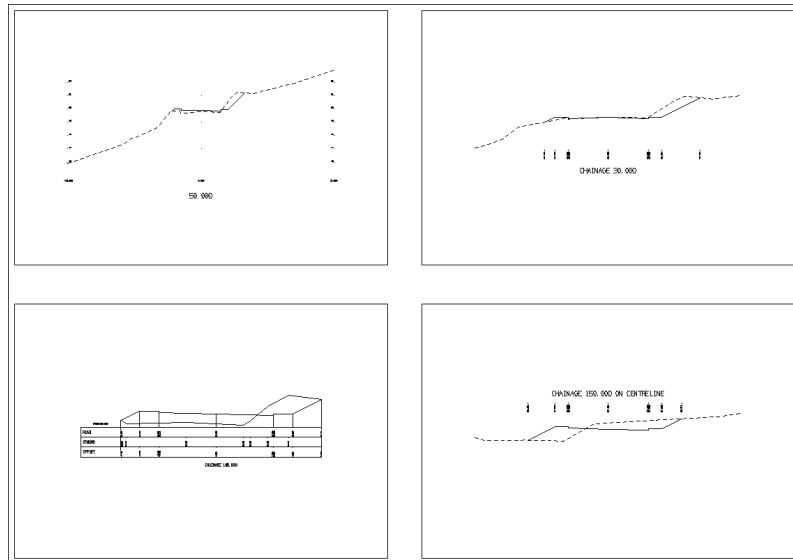


Figure 3 - 52 Example - section annotation

Section drawings are generated by constructing each section as an independent sub picture 'section object' and only when all section objects are complete is their arrangement in the drawing window completed. For each section object there is a drawing area and the annotation 'boxes' are based on this drawing area. Together the drawing area and the annotation area comprise the section object area.

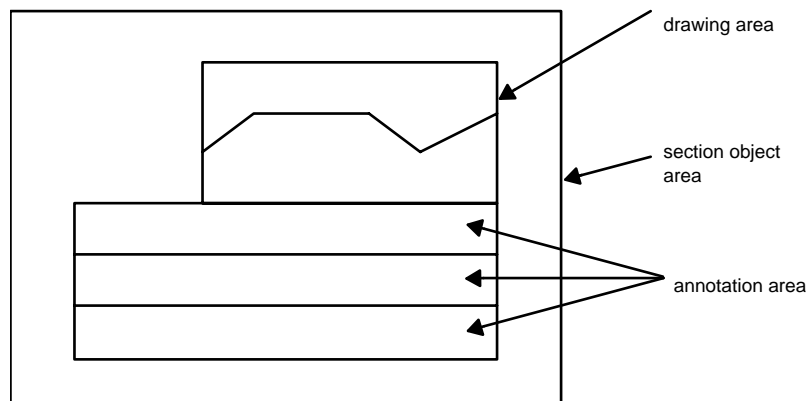


Figure 3 - 53 Example - section object area

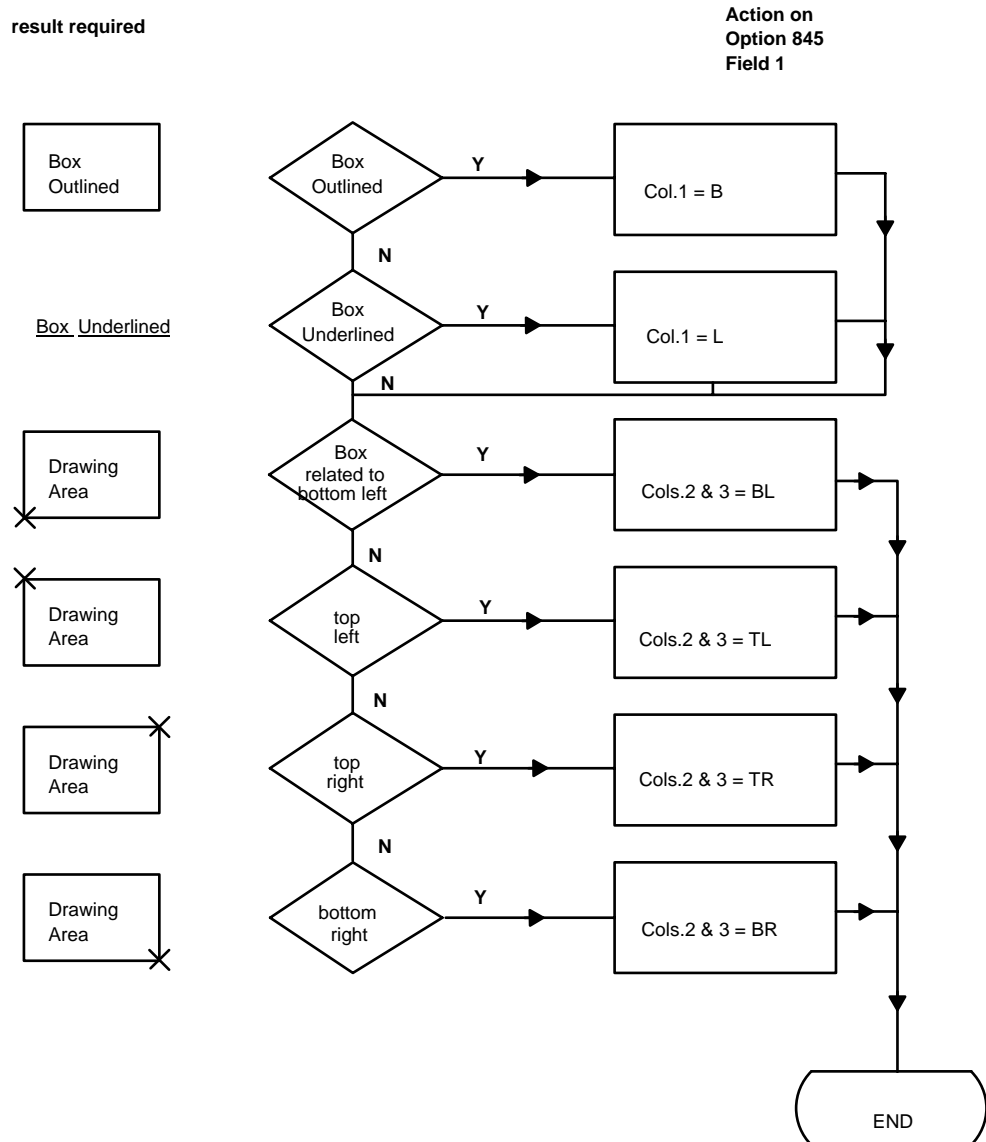
Inside each box area, descriptive information (offsets, levels, distances etc) will be arranged according to the user's specification.

The annotation area is a combination of boxed area, each drawn with or without the outline. Each uniquely named boxed area is first defined relative to any corner of the drawing area and the actual contents of the box is then specified.

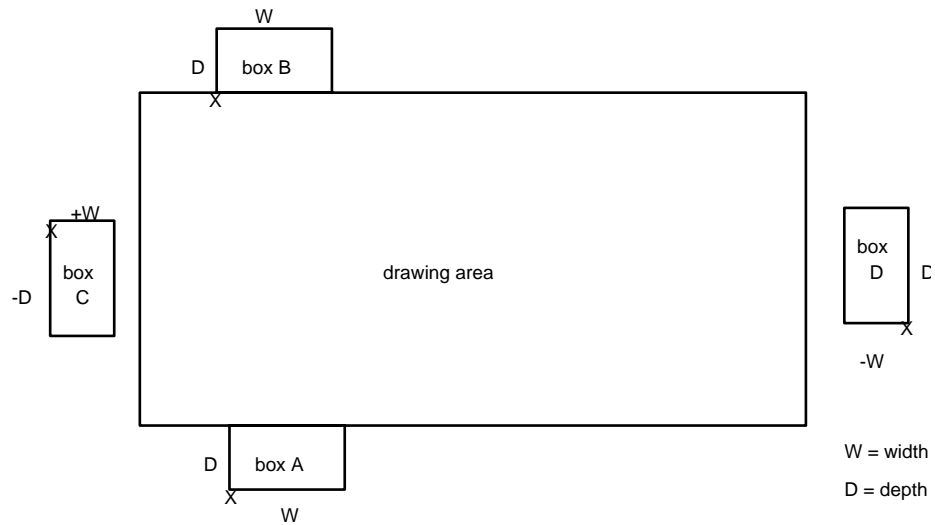


**Box layout**

The position of the box relative to the drawing may be derived from the following flowchart :-



The size and position of each annotation box is defined relative to the reference point of the drawing area by considering the reference point as being any of the four corners and positioning the bottom left corner of the box relative to that corner. The positioning measurements may be in model or drawing coordinates or a mixture of the two.



**Figure 3 - 54 Examples - box layout**

BOXA is drawn outlined and based on the Bottom Left of the drawing area displaced by model units horizontally and drawing units vertically.

BOXB is drawn underlined, based on the Top Left of the drawing area.

BOXC is neither underlined nor boxed and is based on the Bottom Left of the drawing area.

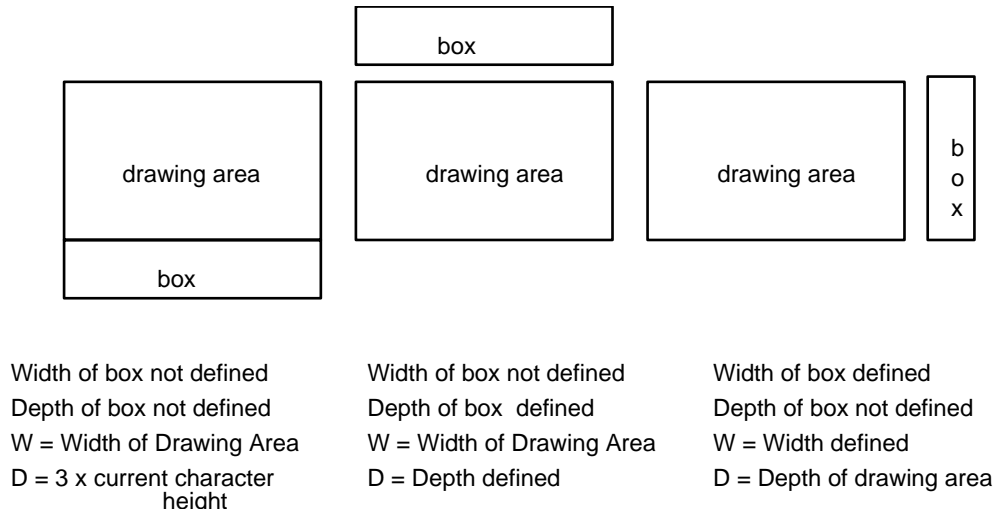
◇ *The base point of BOXC is the top left corner and the box is orientated downwards with a negative depth.*

Alternatively BOXC may be based on the Top Left corner of the drawing area.

BOXD is defined based on the Bottom Right of the drawing area.

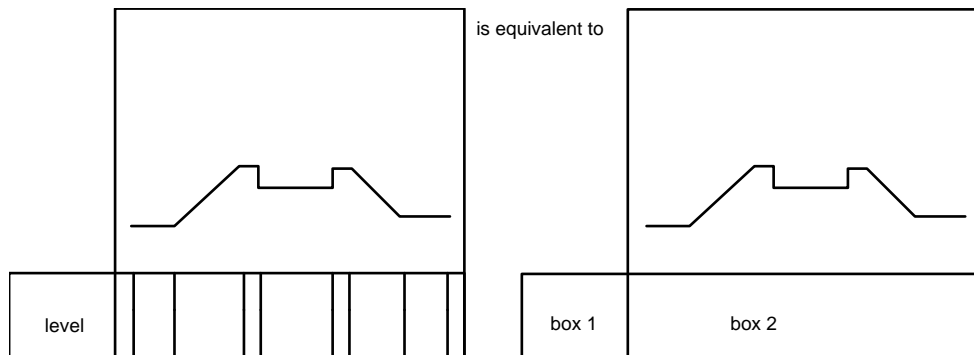
The X and Y dimension of size of each box is measured in the same units as the measurement from the reference point. Thus the width of BOXA would be defined in model units whilst the depth would be measured in drawing units. It is often appropriate to quote a negative dimension to define the box position. BOXC could have a width of +0.5 drawing units and a depth of -20 model units.

If all the dimensions are not explicitly given by the user the following defaults are assumed, for those which are not defined.



**Figure 3 - 55 Box dimension - defaults**

In developing the layout of the annotation boxes the user should be aware that string information and its description will normally require at least 2 boxes. For example, BOX1 (below) contains the descriptive title for the contents of BOX2.



**Figure 3 - 56 Box layout - title and content**

**Box content**

Associated with each named annotation box is text which will be contained within it. There are 3 methods of specifying the box contents.

1. Extract variable information from a string such as the levels along a profile (minor option 846).
2. Explicitly define the text such as the descriptor information of 'CHAINAGE', 'LEVEL', (minor option 847).
3. Extract single value information from a string (minor options 848 and 847).

Figure 3 - 57 illustrates where each of the three methods would be used.

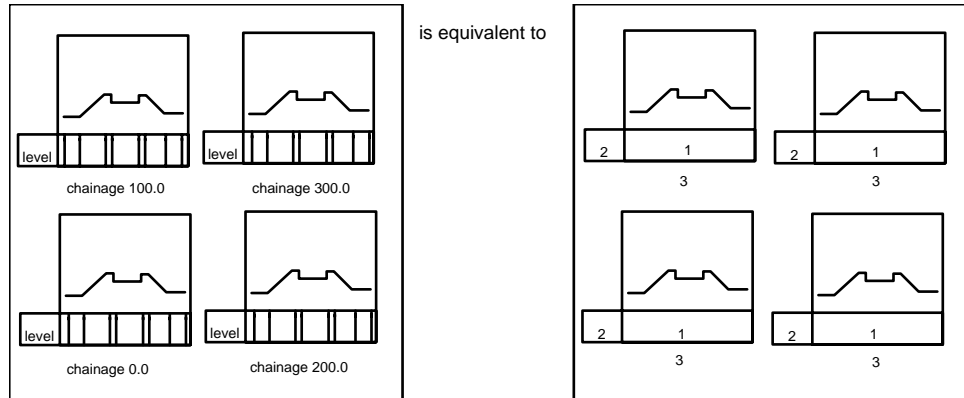


Figure 3 - 57 Examples - box content specification

For all cases the text needs positioning and orientating. There are 3 x 3 possibilities for positioning the text within each named box as illustrated.

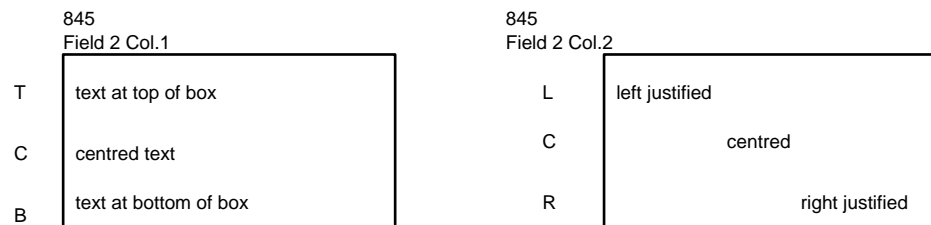


Figure 3 - 58 Examples - text positioning within a box

Even within the box the text need not be horizontally or vertically aligned but may be orientated at any angle relative to the left hand side of the drawing window.

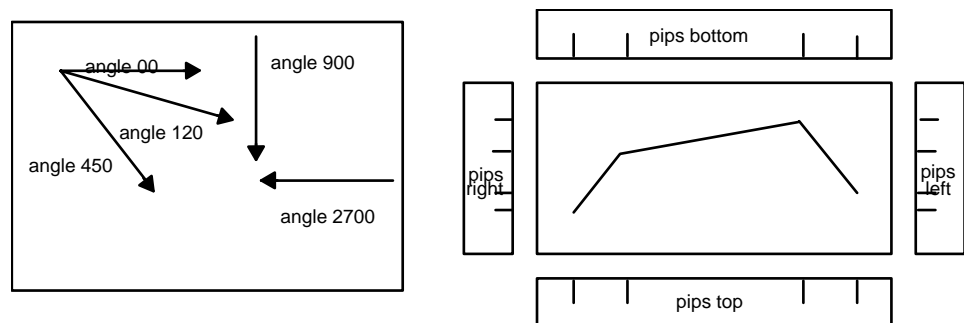


Figure 3 - 59 Examples - pip positioning within a box

Pips may be placed at the left or right hand side, top or bottom of the box and will normally be chosen dependent on the position of the box relative to the section drawing area.

Method 1. Variable Text - Option 846

Any dimension of any string may be extracted over all or part of the string and placed within a box and an interval may be defined. The interval need not always be a chainage interval but may be a point number interval, ie every second point or every third point. In addition to the dimensions of the string, ancillary information such as the string label or point sequence number may be accessed.

Methods 2/3. Descriptor Text - Options 847/848

There is a predefined set of words, - CHAINAGE; DISTANCE; LEVEL: PROPOSED: EXISTING each of which is frequently used in section drawings and can be easily invoked. Alternatively user defined text within a box which may contain 'text variables' may be included.

The legend 'CHAINAGE xxxx.xx' often appears beside each section in a set of cross section drawings. The value xxxx.xx will vary for each section and is defined to the program as a text variable on option 847 and its value is extracted according to the specification contained on option 848.

◇ *it is important to note that whenever 848 text variables are used 848 must be defined before the 847 which refers to it.*

### Ordinate Drawing Option 849

The drawing of ordinates has been separated from the box annotation and string drawing options to give added flexibility. By repeated use of the option either horizontal and/or vertical ordinates may be drawn associated with any of the strings within the drawing area. It should be noted that the ordinate drawing option is independent of the grid option 822.

### Point annotation options 860 - 869

Minor options 825/826 draw strings according to the current line style defined with option 810. However within the drawing window or area the user may wish to annotate particular points. Indeed the strings themselves may only need to be represented as points and may not have been drawn.

The annotation of string points fall into two categories

1. Annotation of points with symbols.
2. Annotation of points with numerical information.

The application of the annotation is fully described under the appropriate detailed minor option description.

### General drawing enhancement

#### Major option ENHANCE

The inclusion of additional notes, construction lines and symbols is an integral part of drawing production. Complex enhancements may be added to drawings from simple basic elements of arc, lines and text. Major option ENHANCE is provided to add non-model information to a drawing. The ENHANCE options operate on the picture file produced by major option DRAW. Normally the option is used in interactive mode (IGMODE) but it may also be used in LINEMODE.

## Major option DRAW

There are essentially three stages involved in creating a drawing. They are Selection, Drawing and Enhancement. Clipping is an optional stage which is performed following Enhancement.

**SELECTION.** The materials, styles and characteristics of the drawing need to be specified. eg

- Select Drawing and Sheet Layout.
- Select the relationship between the model and the drawing.
- Select those parts of the model to be drawn.
- Select pen types, styles and colours.
- Select curve fitting styles and characteristics.
- Select and define clipping.

**DRAWING.** The component parts of the picture have to be actually drawn. eg

- Draw the frame and grid.
- Draw the strings.
- Draw the axis annotation and ordinates.
- Draw the string annotation as symbols, pips, macrolines etc.
- Hatch within a boundary, between strings etc.

**ENHANCEMENT.** Additional information and details which are not necessarily model dependent but are related to the drawing itself need adding. This is done using ENHANCE.

**CLIPPING.** When all the drawing information is in place, a clipping process may be used to remove unwanted information lying on top of annotation, symbols or other areas of the drawing which need to be clear of superfluous information. Major option CLIP is used to carry out the clipping process.

The following table relates these functions to their associated minor option.

**DRAW**

<b>SELECTION</b>	Define sheet	Drawing and Page layout Relationship between Model and Drawing Domain of Model	800/801/802 803 804
	Environment	Pen type and colour for lines	805
		Pen type and colour for text	806
		Hatching characteristics	807
		Text characteristics	808
		Geometry string code	809
		Line characteristics	810
		Curve fitting characteristics	812
		Object manipulation	814/815/817
		Clipping	818/819
<b>DRAWING</b>	Background	Frame/Grid	821/822
	Strings	Ordinary	825/826
		Triangles	827
		Drainage	828/829
		Text	830
	Raster	Raster backcloth	831
	String annotation	Axis annotation	845/846/847/ 848
		Ordinates	849
		Profile schematics	701 - 734
		Labels	825
Crossfall		853	
Symbols	At Intersection points	854/857	
	Draw cadastral symbols	856	
	Pips	860	
	Macro symbols	861/862	
Information	Standard symbols	863	
	Between points	864/858	
	At points	859	
	Sequence numbers	865	
	Chainages	866/867	
	Levels	868	
Hatching	Any dimension	869	
	Triangles	870	
	2 strings	875/876	
	2 lines	877/878	
	Boundary string	879	

**ENHANCE**

	Define sheet	Define extent	880
	Draw	Mesh	881

<b>ENHANCE</b>		Line	882
		Text	883/884
	Figure	Macro Symbol	886
		Standard symbol	887
		Rectangle	888
		Arc	889/890
	Hatching	Boundary element	894
		2 elements	895
2 lines		896/897	

**The SELECTION minor options available in DRAW are:-**

Option	Description
800	Select drawing material and sheet parameters.
801	Select overplot.
802	Select sheet layout and margins.
803	Select relationship of model coordinate system to drawing coordinate system, including scaling and rotation.
804	Select region (domain) of model being drawn.
805	Select pen type, size and colour for lines.
806	Select pen type, size and colour for characters.
807	Select colour for hatching/fill area.
808	Select character font, style and size.
809	Select geometry string code
810	Select line type, and style.
812	Select curve fitting style and tolerance.
814	Initialise an object grouping.
815	Terminate an object grouping.

**The DRAWING minor options available in DRAW are:-**

Option	Description
<b>Draw macro</b>	
	Draw using a macro 900
<b>Erase strings</b>	
817	Erase string
<b>Clipping polygons</b>	
818	Set clip status
819	Set clip parameters
<b>Draw framework</b>	
821	Draw a frame.
822	Draw a grid.



### Draw strings

- 825 Draw selected strings.
- 826 Draw a string using current line style.
- 827 Draw triangulation string.
- 828 Draw drainage network.
- 829 Draw drainage section.
- 830 Draw a text string.

### Draw backcloths

- 831 Draw raster backcloth.

### Draw string annotation

The following options relate to long and cross section drawings only.

- 845 Define layout for axis annotation.
- 846 Define string contents of axis annotation.
- 847 Define text contents of axis annotation.
- 848 Define variable string contents of axis annotation.
- 849 Draw ordinates from axes.

### Profile schematics

The following options relate to long section drawings only.

- 701 Define the reference string and standard point reference data.
- 711 Draw a general schematic line.
- 712 Draw linework for a vertical schematic in an annotation box.
- 713 Draw linework for a vertical schematic on a profile drawing.
- 714 Draw circular linework for a vertical schematic.
- 721 Annotate the schematic line defined in minor options 701 and 711.
- 722 Annotate the vertical schematic, defined in minor option 712.
- 723 Annotate the vertical schematic, defined in minor option 713.
- 724 Annotate the circular schematic, defined in minor option 714.
- 731 Draw the vertical ordinates on the schematic diagram defined in related minor options 701, 711 and 721
- 732 Draw the ordinates on the vertical schematic diagram defined in related minor options 712 and 722.
- 733 Draw the ordinates on the vertical schematic diagram defined in related minor options 713 and 723.
- 734 Draw and annotate the key diagram for the vertical schematic diagram defined in related minor options 713 and 724.

### Draw point annotation

The following options relate to plan (P), long section (LS) or cross section (CS) drawings as indicated.

853	Annotate crossfall (P)
854	Annotate vertical information points (LS)
856	Draw cadastral symbols. (P)
857	Draw text at intersection points. (LS)
858	Draw information along a string. (P, LS)
859	Draw information at points. (P, LS)
860	Draw pips. (P, LS)
861	Draw macrosymbols. (P, LS, CS)
862	Draw automatically scaled macrosymbols. (P, LS, CS)
863	Draw standard symbols. (P, LS, CS)
864	Draw string dimension between points. (P, LS, CS)
865	Draw point sequence numbers. (P)
866	Draw chainages on 1 side only. (P)
867	Draw on both sides. (P)
868	Draw spot levels. (P, LS, CS)
869	Draw string dimension content. (P, LS, CS)

### Hatching

The following options relate to plan drawings only.

870	Fill triangulation
875/876	Hatch between 2 strings
877/878	Hatch between 2 lines
879	Fill area inside a boundary string

### The ENHANCEMENT minor options available in ENHANCE are:-

880	Define the extent of enhancement.
881	Draw a mesh.
882	Draw a line between two points.
883/884	Draw text.
885	Erase inside a local area.
886	Draw a macrosymbol.
887	Draw a standard symbol.
888	Draw a rectangle.
889	Draw a circle.
890	Define extent for drawing a circular arc.
894	Hatch inside a boundary element
895	Hatch between 2 elements
896/897	Hatch between 2 lines

Minor options 880-897 are intended to permit enhancing of drawings at an early stage. More comprehensive enhancing facilities exist within major option ENHANCE available through Interactive MOSS.

899 Report the installed DRAW list of defaults.

## String dimensions

Some of the minor options available in DRAW use the information stored with each string in the model file to annotate the string. The available information is accessed by specifying a negative dimension in the field data of the minor option.

Figure 3 - 60 shows the minor options which use string dimensions for annotation.

Figure 3 - 61 shows the dimensions associated with horizontal intersection point annotation.

Dim.	Description	Minor options											
		721	722	723	724	846	848	854	858	859	864	868	869
-1.0	String label					√	√		√	√	√	√	√
-2.0	Sub reference					√	√		√	√	√	√	√
-3.0	String contents indicator					√			√	√	√	√	√
-4.0	No. of points					√	√		√	√	√	√	√
-5.0	Min X coord					√			√	√	√	√	√
-6.0	Min Y coord					√			√	√	√	√	√
-7.0	Max X coord					√			√	√	√	√	√
-8.0	Max Y coord					√			√	√	√	√	√
-9.0	Datum of profile (sections)					√	√				√		
-11.0	Point sequence no					√	√		√		√	√	√
-21.0	Partial distances		√	√	√	√		√	√	√	√	√	√
-22.0	Cumulative distances					√			√	√	√	√	√
-23.0	Percentage gradient	√	√	√	√	√		√	√	√	√	√	√
-24.0	Level differences					√			√	√	√	√	√
-25.0	Radius and RL/A value											√	√
-30.0	Horizontal schematic -1					√							
-33.0	Horizontal schematic - 4					√							
-34.0	Vertical schematic -1					√							
-35.0	Vertical annotation					√							
-36.0	Crossfall schematic					√							
-37.0	Superelevation annotation					√							
-38.0	Widening width	√											
-39.0	Widening chainage	√											
-40.0	Length of straights	√							√				
-41.0	Bearing of straights								√				
-42.0	RL/A value of transitions	√							√				
-43.0	Length of transitions	√							√				
-44.0	Radius of curves	√							√				
-45.0	Length of curves	√							√				

-46.0	Horiz. tangent point labels									√	√
-47.0	Vert. tangent point labels									√	√
-48.0	Radius of straight	√									
-50.0	Preceding vert. tangent length (G strings)		√		√				√		
-51.0	Following vert. tangent length (G strings)				√				√		
-52.0	Vert. IP to alignment distance (G strings)			√					√		
-53.0	Vertical radius (G strings)	√			√				√		
-54.0	Vertical M value (G strings)								√		
-60.0	Vert. IP X coordinate	√	√	√	√						
-61.0	Vert. IP Y coordinate	√	√	√	√						
-62.0	Vert. IP level		√		√						
-63.0	Vert. IP chainage		√								
-64.0	Vert. IP deflection angle										
-65.0	Vert. IP leading gradient				√						
-66.0	Vert. IP following gradient				√						
-67.0	Vert. IP gradient difference										
-68.0	Vert. IP vertical curve length	√		√							
-69.0	Vert. IP number	√	√	√	√						
-70.0	HIP X coordinate								√		√
-71.0	HIP Y coordinate								√		√
-72.0	HIP level								√		√
-73.0	HIP chainage								√		√
-74.0	HIP tangent length								√		√
-75.0	HIP length of whole curve (curve + transitions)								√		√
-76.0	HIP deflection angle								√		√
-77.0	HIP whole circle bearing								√		√
-78.0	HIP long chord								√		√
-79.0	HIP curve to chord distance								√		√
-80.0	HIP semi deflection angle (deflection angle/2)								√		√
-81.0	HIP to curve length								√		√
-90.0	Rate of change of superelevation (%)	√									
-91.0	Value of superelevation (%)	√									
-92.0	Amount of upstand (model units)	√									
-93.0	Chainage at superelevation change points	√									

Figure 3 - 60 Annotation using string dimensions

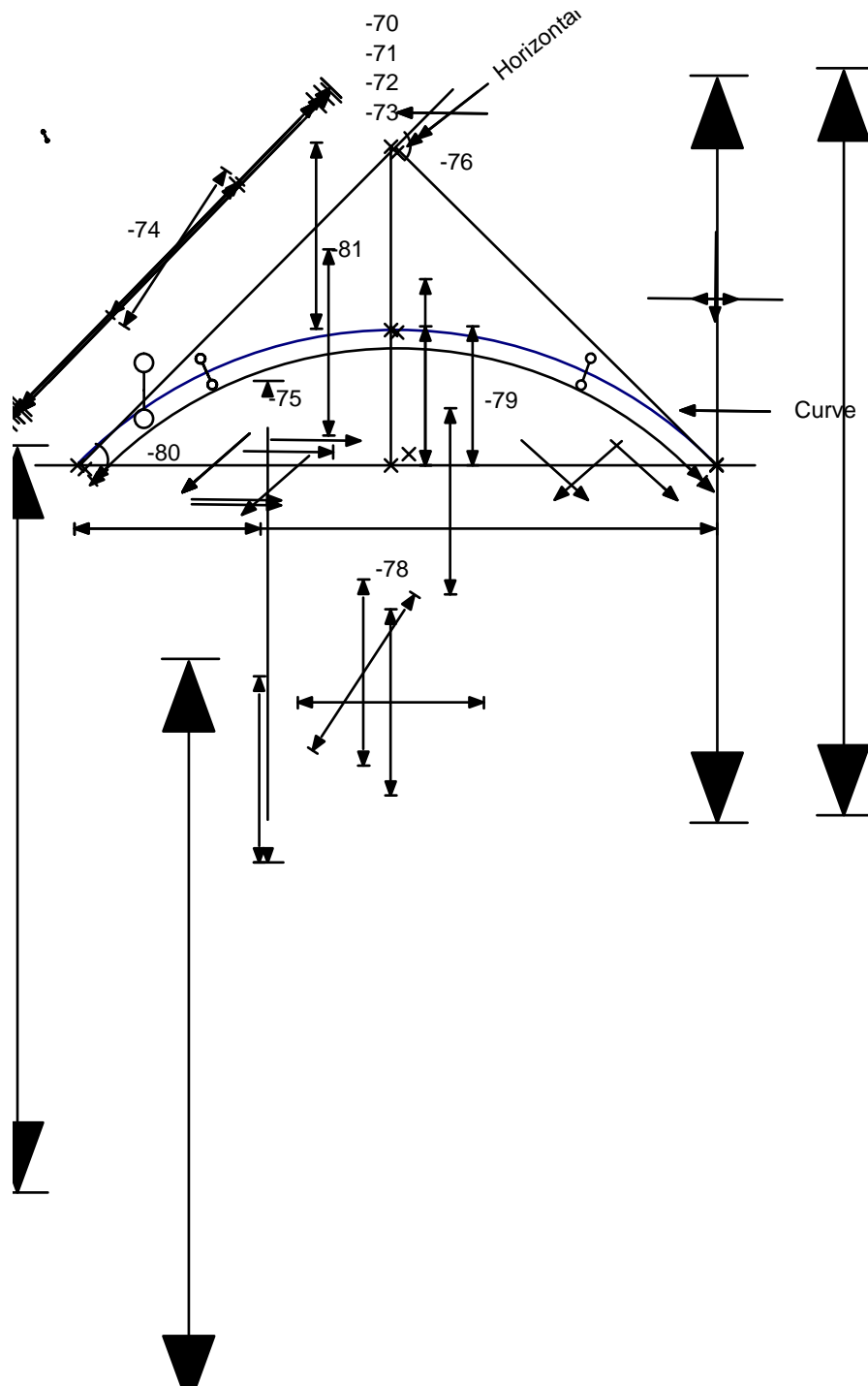


Figure 3 - 61 Horizontal intersection point annotation

### Cadastre string dimensions

Dimension information stored in cadastre strings may be accessed by specifying the dimension in the field data of the minor option which is to use the data, for example, minor option 859, 'Information at points'. This allows the information stored in cadastre strings to be used as annotation.

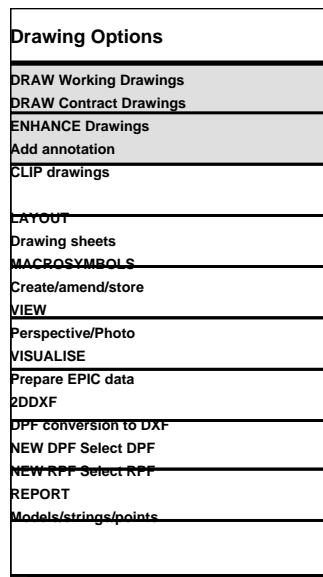
Figure 3 - 62 shows the minor options which use cadastre string dimensions.

Dimension	Description	Minor options		
		856	859	869
1	X coordinate		√	√
2	Y coordinate		√	√
3	Z coordinate		√	√
4	Symbol reference bearing		√	√
5	Survey point number		√	√
6	Point feature code	√	√	√
7	Cadastre point number		√	√

Figure 3 - 62 Cadastre annotation

## Access to major option DRAW

GEN005



**DRAW - working drawings:** This selection provides the most effective route throughout the design phases of a project. The facilities allow you to:

- Work with an assumed scale
  - Quickly define or re-define areas of immediate interest
  - Maintain the 'elastic' boundary associated with the model being developed. This may be thought of as one drawing sheet of infinite size including everything in a model or group of models to produce a picture
  - Enhance by addition of key and title information.
- ◇ *When working drawings are selected the Create new sheet option is omitted from the Draw option details menu.*

**DRAW - contract drawings:** This selection allows you to create the drawings necessary to document a project. Its facilities allow you to:

- Define an exact sheet size and drawing scale
- Define the number, size, location and orientation of each sheet required
- Enhance by addition of standard or customised drawing frames, files and key information.

## Model for DRAW

IGDRAWT.DAT, DRW001

Model for DRAW
Model to be drawn
Boundary model (optional)

### Data Preparation

Major option DRAW

1st Model 1 Model containing strings to be drawn.

2nd Model 2 Model containing reference strings, if not in the 1st model.  
Otherwise leave blank.

If a temporary model is to be drawn, for example as a result of contouring, leave both model names blank.

### Minor options

The global minor options 000, 017, 018, 019, 900 and 999 may be used.

To make the system easier to use, many of the commonly used facilities may be embodied in the system when MOSS is installed. In the following minor options any field marked may be left blank and the installed default value will be assumed and invoked.

The defaults assigned to a particular installation may be ascertained by using minor option 899 to produce a printed listing of default values as follows:-

DRAW, SIMPLE DESIGN ROAD  
899  
999

◇ *The minimum data input to produce a drawing uses minor options 803 and 825.*

## DRAW Minor options 701 - 734

### Introduction

The minor options used in DRAW are shown in numerical order, the 700 series are used only to draw complex long sections, for information on the fundamental DRAW minor options see Minor option 800 Define sheet details.

DRAW Minor options 701 - 734 provide increased flexibility of horizontal, vertical and superelevation annotation specific to international drawing standards for long section drawing. These minor options are grouped according to their function. Many different styles of annotation can be catered for and examples of the major ones are shown below.

A set of command macros is provided to assist the production of profile drawings with annotation. To find out more about the macros type MACRO then 903,index at the MOSS prompt. The following listing will be generated.

#### LISTING OF MACRO 'INDEX' -----

```

INDEX MOSS
M.S.L. Macro listing new drawing macros, with description.
FORMAT
A80
OPTION
000
000 New macros for use with profiles using new DRAW 700-733 options
000
000 HORIZSC
000 -----
000 Macro for profile Horizontal annotation Type 1 as shown
000 in the manual Chapter 3 Draw minor options 701 - 734
000 Figure 3 - 62 v10.3 manual
000
000 To recreate the style shown in the manual
000 minimum entry :-
000
000 900,longdraw
000 hs=500,vs=100,lb=mast,lr=mast
000 900,horizsc
000 gr=gast
000 999

```



```

000
000   To see full listing of defaults
000       macro
000       903,horizsc
000       999
000
000 SUPERSC
000 -----
000   Macro for profile Superelevation Type 1 as shown
000   in the manual Chapter 3 Draw minor options 701 - 734
000   Figure 3 - 65 v10.3 manual
000
000   To recreate the style shown in the manual
000   minimum entry :-
000
000       900,longdraw
000       hs=500,vs=100,lb=mast,lr=mast
000       900,supersc
000       lr=mast,lchn=cccl,rchn=cccr
000       999
000
000   To see full listing of defaults
000       macro
000       903,supersc
000       999
000
000 VERTSC1
000 -----
000   Macro for profile Vertical annotation Type 1 as shown
000   in the manual Chapter 3 Draw minor options 701 - 734
000   Figure 3 - 64 v10.3 manual
000
000   To recreate the style shown in the manual
000   minimum entry :-
000
000       900,longdraw
000       hs=500,vs=100,lb=mast,lr=mast
000       900,vertsc1
000       gr=gast
000       999
000
000   To see full listing of defaults
000       macro
000       903,vertsc1
000       999
000
000 VERTSC21
000 -----
000   Macro for profile Vertical annotation Type 2 as shown
000   in the manual Chapter 3 Draw minor options 701 - 734
000   Figure 3 - 65 & Minor option 732 example 1 v10.3 manual

```

```

000
000   To recreate the style shown in the manual
000   minimum entry :-
000
000       900,longdraw
000       hs=500,vs=100,lb=mast,lr=mast
000       900,vertsc21
000       gr=gast
000       999
000
000   To see full listing of defaults
000       macro
000       903,vertsc21
000       999
000 VERTSC23
000 -----
000   Macro for profile Vertical annotation Type 2 example 3 as
000   shown in the manual Chapter 3 Draw minor options 701 - 734
000   Minor option 732 example 3 Figure 3 -76 v10.3 manual
000
000   To recreate the style shown in the manual
000   minimum entry :-
000
000       900,longdraw
000       hs=500,vs=100,lb=mast,lr=mast
000       900,vertsc23
000       gr=gast
000       999
000
000   To see full listing of defaults
000       macro
000       903,vertsc23
000       999
000
000 VERTSC4
000 -----
000   Macro for profile Vertical annotation Type 4 as shown
000   in the manual Chapter 3 Draw minor options 701 - 734
000   Figure 3 - 68 v10.3 manual
000
000   To recreate the style shown in the manual
000   minimum entry :-
000
000       900,longdraw
000       hs=500,vs=100,lb=mast,lr=mast
000       900,vertsc4
000       gr=gast
000       999
000
000   To see full listing of defaults

```

```

000      macro
000      903,vertsc4
000      999
000
000 VERTSC31
000 -----
000      Macro for profile Vertical annotation Type 3 style 1 as shown
000      in the manual Chapter 3 Draw minor options 701 - 734
000      Figure 3 - 66 style 1 v10.3 manual
000
000      To recreate the style shown in the manual
000      minimum entry :-
000
000      900,longdraw
000      hs=500,vs=100,lb=mast,lr=mast,yo=12,sf=vs
000      900,vertsc31
000      gr=gast,intedist=20
000      999
000
000      To see full listing of defaults
000      macro
000      903,vertsc31
000      999
000
000 VERTSC32
000 -----
000      Macro for profile Vertical annotation Type 3 style 2 as shown
000      in the manual Chapter 3 Draw minor options 701 - 734
000      Figure 3 - 67 style 2 v10.3 manual
000
000      To recreate the style shown in the manual
000      minimum entry :-
000
000      900,longdraw
000      hs=500,vs=100,lb=mast,lr=mast,yo=12,sf=vs
000      900,vertsc32
000      gr=gast
000      999
000
000      To see full listing of defaults
000      macro
000      903,vertsc32
000      999
000 -----
000
000 WIDESC
000
000      Macro for profile Widening schematic Type 1 as shown
000      in the manual Chapter 3 Draw minor options 700 - 734
000      Figure 3 - 66 v10.5 manual
000

```

000 To recreate the style shown in the manual  
000 minimum entry for single carriageway:-

```
000 900,longdraw
000 hs=500,vs=100,lb=mast,lr=mast
000 900,widesc
000 lr=mast,lch1=mast,lch2=cccl,
000 rch1=mast,rch2=cccr
000 999
```

000 To recreate the style shown in the manual  
000 minimum entry for dual carriageway:-

```
000 900,longdraw
000 hs=500,vs=100,lb=mast,lr=mast
000 900,widesc
000 lr=mast,lch1=ccl1,lch2=cccl,
000 rch1=ccr1,rch2=cccr
000 999
```

000 VERTSC1

000 -----  
000 Macro for profile Vertical annotation Type 1 as shown  
000 in the manual Chapter 3 Draw minor options 701 - 734  
000 Figure 3 - 64 v10.3 manual

000 To recreate the style shown in the manual  
000 minimum entry :-

```
000 900,longdraw
000 hs=500,vs=100,lb=mast,lr=mast
000 900,vertsc1
000 gr=gast
000 999
```

000 To see full listing of defaults

```
000 macro
000 903,vertsc1
000 999
```

000 VERTSC21

000 -----  
000 Macro for profile Vertical annotation Type 2 as shown  
000 in the manual Chapter 3 Draw minor options 701 - 734  
000 Figure 3 - 65 & Minor option 732 example 1 v10.3 manual

000 To recreate the style shown in the manual  
000 minimum entry :-

```
000 900,longdraw
```

```

000          hs=500,vs=100,lb=mast,lr=mast
000          900,vertsc21
000          gr=gast
000          999
000
000      To see full listing of defaults
000          macro
000          903,vertsc21
000          999
000
000  VERTSC23
000  -----
000      Macro for profile Vertical annotation Type 2 example 3 as
000      shown in the manual Chapter 3 Draw minor options 701 - 734
000      Minor option 732 example 3 Figure 3 -76 v10.3 manual
000
000      To recreate the style shown in the manual
000      minimum entry :-
000
000          900,longdraw
000          hs=500,vs=100,lb=mast,lr=mast
000          900,vertsc23
000          gr=gast
000          999
000
000      To see full listing of defaults
000          macro
000          903,vertsc23
000          999
000
000  VERTSC4
000  -----
000      Macro for profile Vertical annotation Type 4 as shown
000      in the manual Chapter 3 Draw minor options 701 - 734
000      Figure 3 - 68 v10.3 manual
000
000      To recreate the style shown in the manual
000      minimum entry :-
000
000          900,longdraw
000          hs=500,vs=100,lb=mast,lr=mast
000          900,vertsc4
000          gr=gast
000          999
000
000      To see full listing of defaults
000          macro
000          903,vertsc4
000          999
000

```

```

000 VERTSC31
000 -----
000 Macro for profile Vertical annotation Type 3 style 1 as shown
000 in the manual Chapter 3 Draw minor options 701 - 734
000 Figure 3 - 66 style 1 v10.3 manual
000
000 To recreate the style shown in the manual
000 minimum entry :-
000
000 900,longdraw
000 hs=500,vs=100,lb=mast,lr=mast,yo=12,sf=vs
000 900,vertsc31
000 gr=gast,intedist=20
000 999
000
000 To see full listing of defaults
000 macro
000 903,vertsc31
000 999
000
000 VERTSC32
000 -----
000 Macro for profile Vertical annotation Type 3 style 2 as shown
000 in the manual Chapter 3 Draw minor options 701 - 734
000 Figure 3 - 67 style 2 v10.3 manual
000
000 To recreate the style shown in the manual
000 minimum entry :-
000
000 900,longdraw
000 hs=500,vs=100,lb=mast,lr=mast,yo=12,sf=vs
000 900,vertsc32
000 gr=gast
000 999
000
000 To see full listing of defaults
000 macro
000 903,vertsc32
000 999
000 -----

```

The types and styles of drawing that can be created using the 700 series minor options are shown in Figure 3 - 63 to Figure 3 - 70.

LISTING OF MACRO 'INDEX' -----

INDEX MOSS  
M.S.L. Macro listing new drawing macros, with description.  
FORMAT  
A80

OPTION

000

000 New macros for use with profiles using new DRAW 700-733 options

000

000 HORIZSC

000 -----

000 Macro for profile Horizontal annotation Type 1 as shown  
000 in the manual Chapter 3 Draw minor options 701 - 734  
000 Figure 3 - 62 v10.3 manual

000

000 To recreate the style shown in the manual

000 minimum entry :-

000

000 900,longdraw

000 hs=500,vs=100,lb=mast,lr=mast

000 900,horizsc

000 gr=gast

000 999

000

000 To see full listing of defaults

000 macro

000 903,horizsc

000 999

000

000 SUPERSC

000 -----

000 Macro for profile Superelevation Type 1 as shown  
000 in the manual Chapter 3 Draw minor options 701 - 734  
000 Figure 3 - 65 v10.3 manual

000

000 To recreate the style shown in the manual

000 minimum entry :-

000

000 900,longdraw

000 hs=500,vs=100,lb=mast,lr=mast

000 900,supersc

000 lr=mast,lchn=cccl,rchn=cccr

000 999

000

000 To see full listing of defaults

000 macro

000 903,supersc

000 999

000

000 WIDESC

000

000 Macro for profile Widening schematic Type 1 as shown  
000 in the manual Chapter 3 Draw minor options 700 - 734  
000 Figure 3 - 66 v10.5 manual

000

000 To recreate the style shown in the manual

```

000      minimum entry for single carriageway:-
000
000      900,longdraw
000      hs=500,vs=100,lb=mast,lr=mast
000      900,widesc
000      lr=mast,lch1=mast,lch2=cccl,
000      rch1=mast,rch2=cccr
000      999
000
000      To recreate the style shown in the manual
000      minimum entry for dual carriageway:-
000
000      900,longdraw
000      hs=500,vs=100,lb=mast,lr=mast
000      900,widesc
000      lr=mast,lch1=ccl1,lch2=cccl,
000      rch1=ccr1,rch2=cccr
000      999
000
000
000      VERTSC1
000      -----
000      Macro for profile Vertical annotation Type 1 as shown
000      in the manual Chapter 3 Draw minor options 701 - 734
000      Figure 3 - 64 v10.3 manual
000
000      To recreate the style shown in the manual
000      minimum entry :-
000
000      900,longdraw
000      hs=500,vs=100,lb=mast,lr=mast
000      900,vertsc1
000      gr=gast
000      999
000
000      To see full listing of defaults
000      macro
000      903,vertsc1
000      999
000
000      VERTSC21
000      -----
000      Macro for profile Vertical annotation Type 2 as shown
000      in the manual Chapter 3 Draw minor options 701 - 734
000      Figure 3 - 65 & Minor option 732 example 1 v10.3 manual
000
000      To recreate the style shown in the manual
000      minimum entry :-
000
000      900,longdraw
000      hs=500,vs=100,lb=mast,lr=mast

```



```

000          900,vertsc21
000          gr=gast
000          999
000
000      To see full listing of defaults
000          macro
000          903,vertsc21
000          999
000
000  VERTSC23
000  -----
000      Macro for profile Vertical annotation Type 2 example 3 as
000      shown in the manual Chapter 3 Draw minor options 701 - 734
000      Minor option 732 example 3 Figure 3 -76 v10.3 manual
000
000      To recreate the style shown in the manual
000      minimum entry :-
000
000          900,longdraw
000          hs=500,vs=100,lb=mast,lr=mast
000          900,vertsc23
000          gr=gast
000          999
000
000      To see full listing of defaults
000          macro
000          903,vertsc23
000          999
000
000  VERTSC4
000  -----
000      Macro for profile Vertical annotation Type 4 as shown
000      in the manual Chapter 3 Draw minor options 701 - 734
000      Figure 3 - 68 v10.3 manual
000
000      To recreate the style shown in the manual
000      minimum entry :-
000
000          900,longdraw
000          hs=500,vs=100,lb=mast,lr=mast
000          900,vertsc4
000          gr=gast
000          999
000
000      To see full listing of defaults
000          macro
000          903,vertsc4
000          999
000
000  VERTSC31

```

```

000 -----
000 Macro for profile Vertical annotation Type 3 style 1 as shown
000 in the manual Chapter 3 Draw minor options 701 - 734
000 Figure 3 - 66 style 1 v10.3 manual
000
000 To recreate the style shown in the manual
000 minimum entry :-
000
000     900,longdraw
000     hs=500,vs=100,lb=mast,lr=mast,yo=12,sf=vs
000     900,vertsc31
000     gr=gast,intedist=20
000     999
000
000 To see full listing of defaults
000     macro
000     903,vertsc31
000     999
000
000 VERTSC32
000 -----
000 Macro for profile Vertical annotation Type 3 style 2 as shown
000 in the manual Chapter 3 Draw minor options 701 - 734
000 Figure 3 - 67 style 2 v10.3 manual
000
000 To recreate the style shown in the manual
000 minimum entry :-
000
000     900,longdraw
000     hs=500,vs=100,lb=mast,lr=mast,yo=12,sf=vs
000     900,vertsc32
000     gr=gast
000     999
000
000 To see full listing of defaults
000     macro
000     903,vertsc32
000     999
000 -----

```

Minor options 711, 721 and 731 are specific to general horizontal, vertical, widening or superelevation annotation, (type 1). Minor option 701 defines the reference string and standard point reference data for this group of minor options.

HORIZONTAL TYPE 1 - Style 1

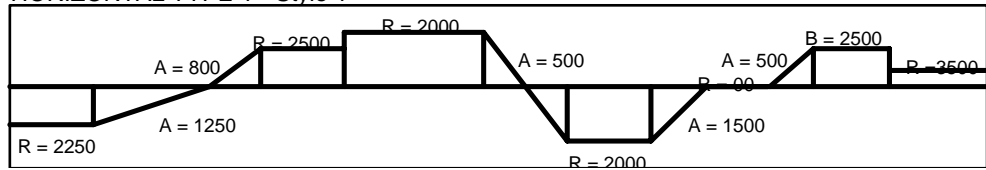


Figure 3 - 63 Example of general type 1 annotation - style 1

VERTICAL TYPE 1 - Style 2

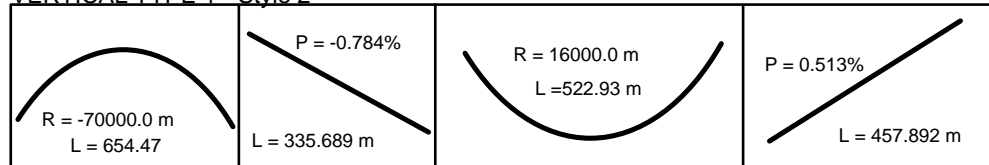


Figure 3 - 64 Example of general type 1 annotation - style 2

SUPERELEVATION TYPE 1 - Style 3

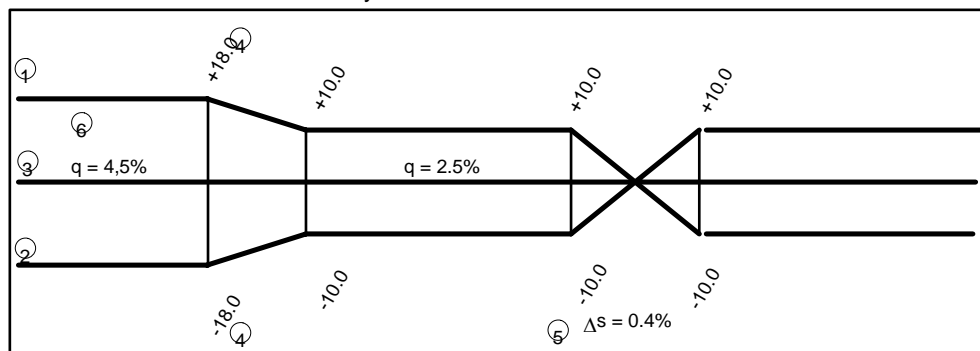


Figure 3 - 65 Example of general type 1 annotation - style 3

HORIZONTAL TYPE 1 - Style 4

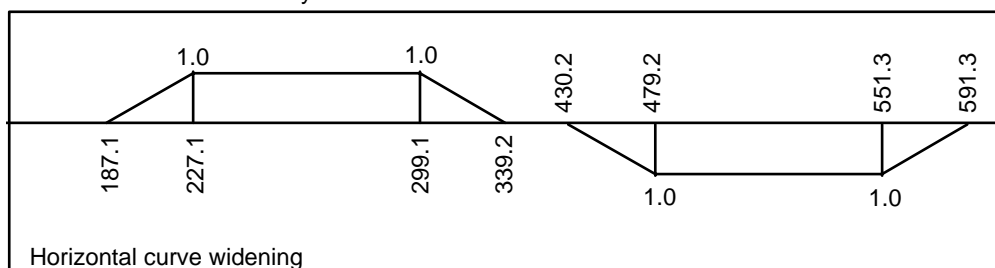


Figure 3 - 66 Example of general type 1 annotation - style 4

Minor options 712, 722, 732 are specific to vertical schematics in annotation boxes (type 2), as shown below:

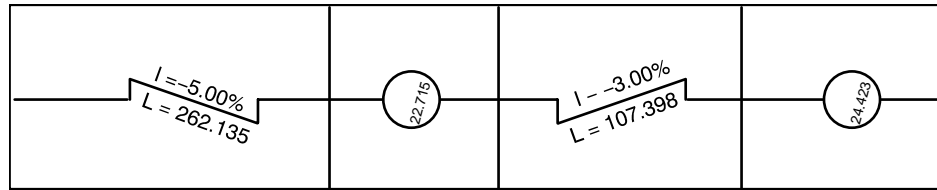


Figure 3 - 67 Example of type 2 annotation

Minor options 713, 723, 733 are specific to vertical annotation on profile (type 3). There are two styles within type 3.

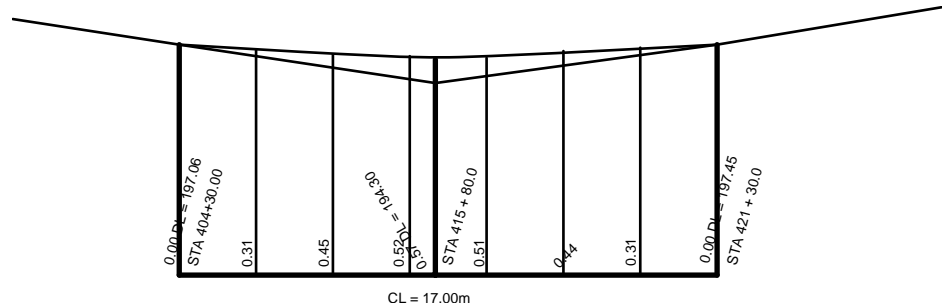


Figure 3 - 68 Example of type 3 annotation - style 1

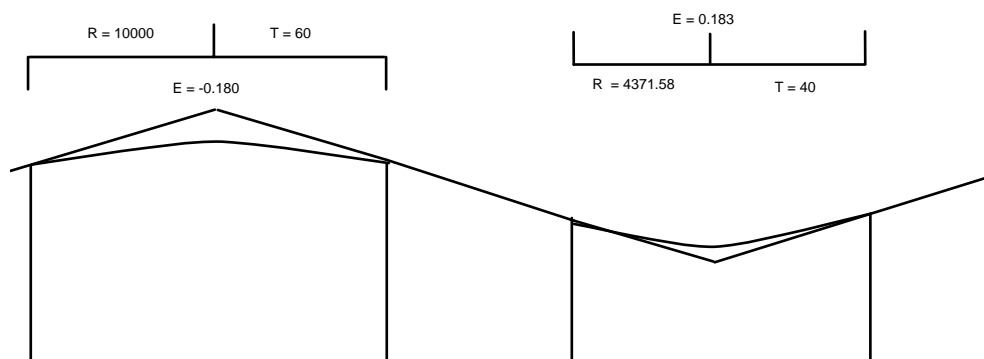


Figure 3 - 69 Example of type 3 annotation - style 2

Minor options 714, 724, 734 are specific to vertical schematics in annotation circles (type 4).

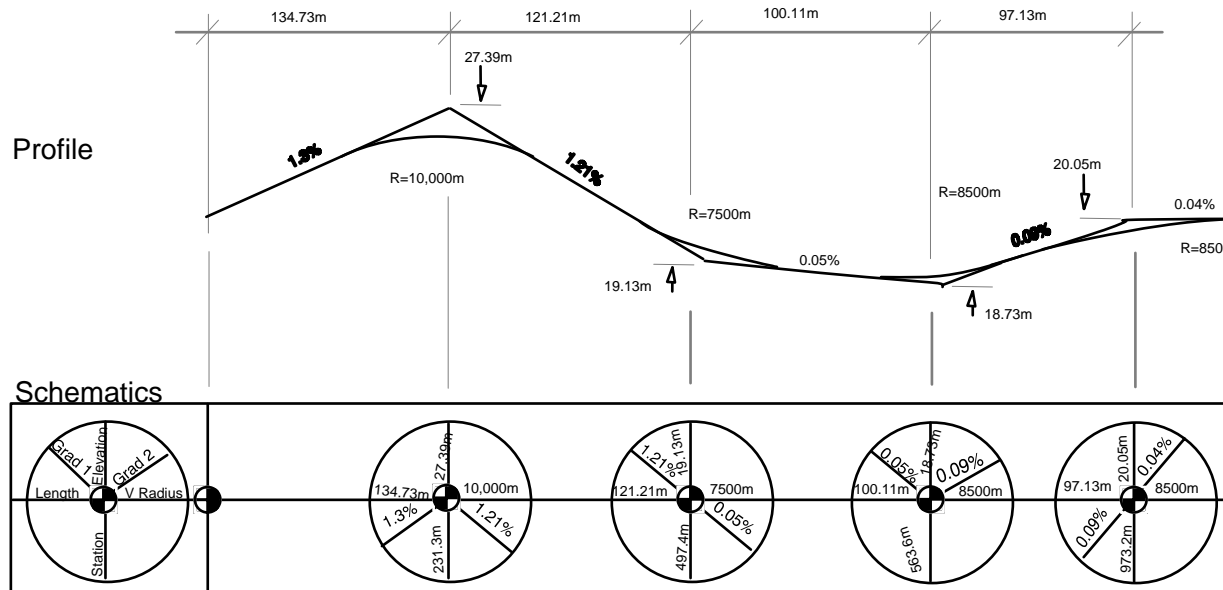


Figure 3 - 70 Example of type 4 annotation

700 series Minor options with a second digit of 1 (eg 712) relate to line drawing, those with a second digit of 2 (eg 722) relate to text annotation and those with a second digit of 3 (eg 732) are specific to ordinates or key diagram. The table below shows how the options interact:

	General Schematic diagrams (type 1)	Vertical Schematic in annotation area (type 2)	Vertical annotation on profile (type 3)	Vertical Schematic in annotation area (type 4)
Reference option for superelevation	701			
Linework	711	712	713	714
Text annotation	721	722	723	724
Diagram ordinates	731	732	733	
Key diagram				734

## Minor option 701 Reference option for superelevation schematics

Minor option 701 defines the reference string and standard point reference data for minor options 711, 721 and 731.

### Input

#### Graphics

This option is not available in graphics mode.

#### Linemode

##### Minor option 701

Field 1 Reference string label (global)

Field 3 Area name (annotation box defined in 845)

Fields 5 & 6 SPRD for start

Fields 8 & 9 SPRD for end

◇ *This option must be used for each Type 1 schematic to be drawn.*

## Minor option 711 Draw schematic line (type 1)

Minor option 711 provides the facilities required to draw a general schematic line using the reference string defined in minor option 701. Related option 721 annotates the line and 731 draws the ordinates.

For superelevation diagrams a separate 711 entry is required for each channel and the combined diagrams of left and right channels are scaled to fit into the available annotation area. To achieve this, a final blank 711 option must be coded.

### Input

#### Graphics

This option is not available in graphics mode.

#### Linemode

##### Minor option 711

Field 1 First string for superelevation calculation  
(if Field 3 = SUPE)  
First string for widening calculation  
(if Field 3 = WIDE).

Field 2 Second string for superelevation calculation, only used for  
dual carriageway annotation (if Field 3 = SUPE)  
Second string for widening calculation, (if Field 3 = Wide)

Field 3 SUPE, CENT, HLIN or VLIN  
SUPE draw the superelevation schematic for the string  
defined in Fields 1 and 2.

CENT	draw the centre line for horizontal schematics.
HLIN	draw the horizontal alignment schematic line.
VLIN	draw the vertical alignment schematic line.
WIDE	draw the widening schematic line.
Field 4	Defines a minimum offset (in drawing units) from the edge of the annotation area to the widest part of the horizontal, vertical or superelevation schematic line. (See Figure 3 - 71).

Example 1

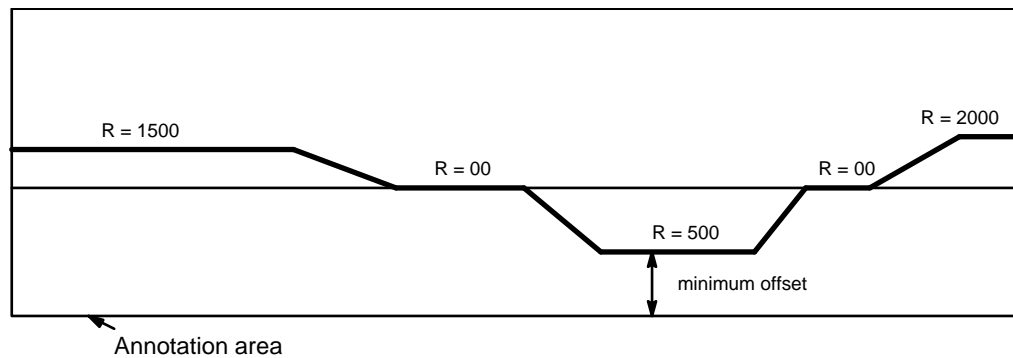


Figure 3 - 71 Annotation area showing minimum offset

Minor option 721 Annotation of schematic (type 1)

Minor option 721 provides the facilities required to annotate with text the schematic line defined in minor options 701 and 711. Related minor option 731 draws the ordinates.

Input

Graphics

This option is not available in graphics mode.

Linemode

Minor option 721

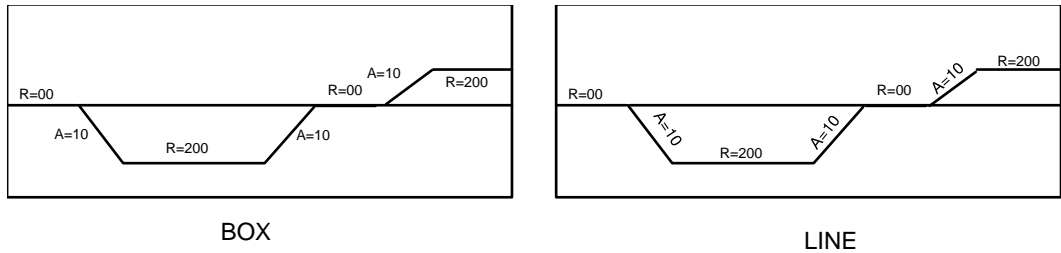
First record

Field 1	String to be annotated
Field 2	BOX = text is drawn relative to annotation area LINE = text is draw relative to the horizontal or superelevation schematic line.
Field 3	Increment or Decrement
Field 7	Text offset
Field 10	Rotation

If the angle is positive, text is positioned measured clockwise relative to the left hand side of the drawing. If negative, text is positioned clockwise relative to the normal lying to the left of the string.

Example 2

This example shows the difference between BOX and LINE in Field 2



**Subsequent records**

Minor option 721

Field 3 Text variable name

Field 4 String dimension to be drawn

◇ *This option must be followed by a 001 record.*

**Minor option 731 Ordinates for schematic diagrams (type 1)**

Minor option 731 provides the facilities required to draw the vertical ordinates on the schematic diagram defined in related minor options 701, 711 and 721.

**Input**

Graphics

This option is not available in graphics mode.

Linemode

Minor option 731

Field 1 String label

Field 3 Each of the following codes will annotate at either the superelevation change points, the horizontal tangent points or vertical tangent points as specified in Field 3 of Minor option 711.

PIP Draw pips at point

LINE Draw ordinate from point to centre of box (default)

BOX Draw ordinates for the full height of the box.

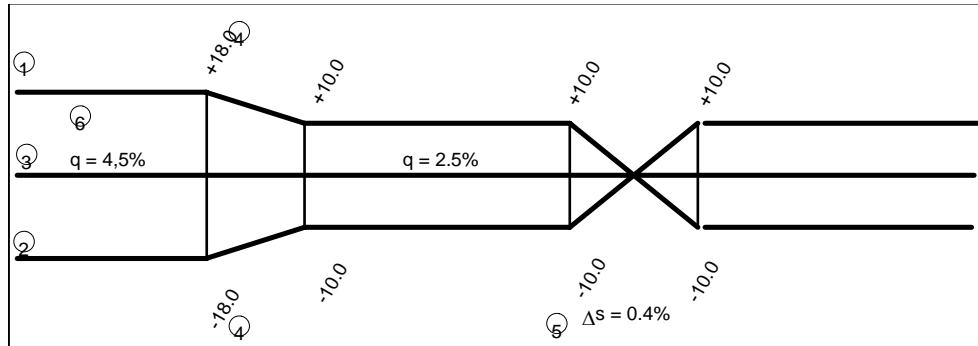
◇ *Field 3 must always be coded.*

◇ *When using VLIN the only available ordinate type is BOX.*



Example 1

This example shows a single carriageway superlevation schematic. See Figure 3 - 72.



Key

- 1 Right channel superlevation shown as dashed line.
- 2 Left channel superlevation shown as solid line
- 3 Zero datum shown as chain dotted line
- 4 Vertical offset drawing units for each channel (+ve above, -ve below)
- 5 Rate of change at crossover point
- 6 Percentage crossfall shown on datum (only on constant crossfall areas)  
annotated at element mid point

**Figure 3 - 72 Example type 1 single carriageway superlevation schematic**

```

moss
draw,demo2
900,longdraw
hs=1000,vs=100,lb=mas2,lr=mas2

```

```

Define annotation area
-----
845,bb1,,3=box1,9=-6.0,3.0

```

```

Reference strings for diagram
-----
701,mas2,ann1,box1

```

```

Line style for centreline
-----
810,dash,5=0.2,0.1,,0.15,0.1

```

```

Draw horizontal line to represent the centreline
-----
711,,,cent

```

```

Line style for right channel
-----

```

```
810,dash,5=0.1,0.05,,0.1,0.01
```

```
Draw right channel
```

```
-----
```

```
711,cri2,,supe,4=1.0
```

```
Solid line style for left channel
```

```
-----
```

```
810
```

```
Draw left channel
```

```
-----
```

```
711,cle2,,supe,4=1.0
```

```
Trigger 711
```

```
-----
```

```
711
```

```
Draw ordinates at superelevation change points
```

```
-----
```

```
731,cle2,,line
```

```
731,cri2,,line
```

```
Annotate right channel with amount of upstand at  
change points, text justified from line
```

```
-----
```

```
808,4=0.18
```

```
721,cri2,line,ic00
```

```
721,3=tva2,4=-92,
```

```
001,&tval&mm
```

```
Annotate left channel with amount of upstand at  
change points, text justified from line
```

```
-----
```

```
721,cle2,line,ic00
```

```
721,3=tval,4=-92
```

```
001,&tval&mm
```

```
Annotate the amount of super on straights at  
element mid points and using increment, text  
justified from box
```

```
-----
```

```
721,cle2,box,I000,10=90
```

```
721,3=tva3,4=-91
```

```
001,q=&tva3&%
```

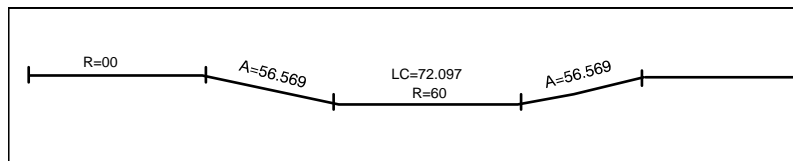
```
Annotate the rate of change of super using  
increment, text justified from box. NB. In this  
case the rate of change is the same for both
```

channels, if it was different another text variable would be needed to annotate rate of change for the left channel.

```
-----
721,cri2,box,i009,10=90
721,3=tva4,4=-90
001,s=&tva4&%
```

Example 2

Example 2 shows a horizontal element schematic



**Figure 3 - 73 Example type 1 - Horizontal element schematic**

```
moos
draw,demo
900,longdraw
hs=1000,vs=100,lb=mast,lr=mast

Define annotation area
-----
845,bb1,,3=box2,9=-6.0,3.0
808,4=0.1
701,gast,,box2

Draw Horizontal Schematic line
-----
711,gast,,hlin

Annotate Straights with infinity symbol
-----
721,gast,line,10=90
721,3=tval,4=-48
001,R=&tval&

Annotate transition A value
-----
721,gast,line,10=90
721,3=tva2,4=-42
001,A=&tva2&

Annotate radius of curves
-----
721,gast,line,i000,10=90
```

```
721,3=tva3,4=-44
001,R=&tva3&
```

Annotate length of curves

```
-----
721,gast,line,i001,10=90
721,3=tva4,4=-45
001,LC=&tva4&
```

Example 3

Example 2 shows a vertical element schematic

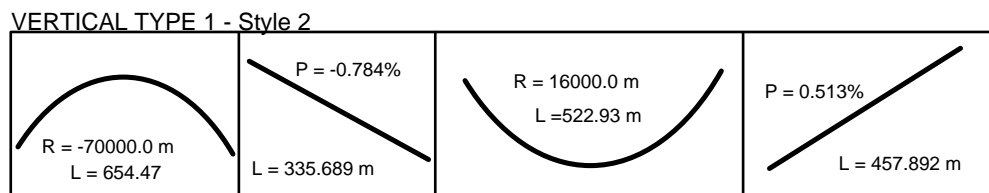


Figure 3 - 74 Example type 1 - Vertical element schematic

```
900,longdraw
hs=1000,vs=100,lb=mast,lr=mast
Set up box and text box width 3.0 cms
```

```
-----
810
805
845,BBL ,BCPT,1009,9=-6.500,3.0
845,BBL ,CL ,3009,6=-6.000,6,, -13.500,3.0
808,4=0.4,,0.75
806
847,*,,3009,10=0
001,VERTICAL
808
```

Specify Reference String for Vertical Schematic diagram

```
-----
701,GAST,,1009
```

Set up line colour and style for Vertical schematic VLIN line and draw it

```
-----
805
806
810
805
711,,,VLIN,0.2
```

Set up text colour and style  
-----

806  
808  
806  
808,4=0.18

Annotate Radius value  
-----

721,GAST,10=90  
721,,,VRTV,-44  
001,Radius =&VRTV&m

Annotate Radius length  
-----

721,GAST,I001,10=90  
721,,,LRTV,-45  
001,Length =&LRTV&m

Annotate Gradient length  
-----

721,GAST,10=90  
721,,,GLTV,-40  
001Length =&GLTV&m

Annotate Gradient  
-----

721,GAST,,I001,10=90  
721,,,GRTV,-23  
001,Gradient =&GRTV&%

Draw ordinates on diagram  
-----

805  
731,GAST,,LINE

Example 4

Example 4 shows a horizontal widening schematic

HORIZONTAL TYPE 1 - Style 4

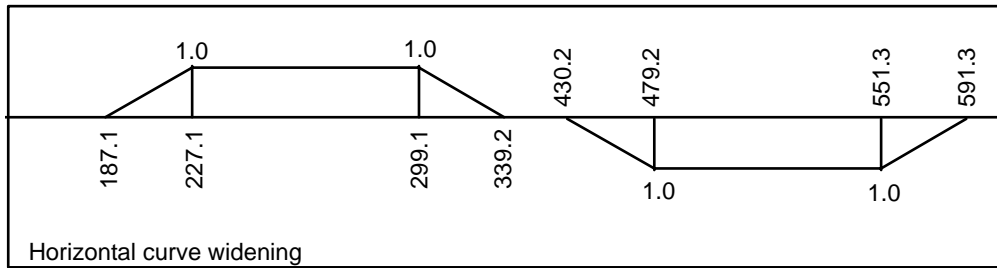


Figure 3 - 75 Example Type 1 - Horizontal widening schematic

Single Carriageway **Single Carriageway**

Specify reference string and box area

-----  
701,mast,,box2,,200,,,560

Specify subsidiary strings and widening for left side

-----  
-reference string and box area711,mast,cool,wide

Specify subsidiary strings and widening for right side

-----  
711,mast,coor,wide

Trigger 711

-----  
711

Annotate chainage of widening change points for left side

-----  
721,cool,,ic00,1,10=90  
721,4=-39

Annotate chainage of widening change points for right side

-----  
721,coor,,ic00,1,10=90  
721,4=-39

Annotate amount of widening for left side

-----  
721,cool,,ic00,1,10=0  
721,4=-38

Annotate amount of widening for right side

```

-----
721,coor,,ic00,1,10=0
721,4=-38

    Annotate ordinates
    -----
731,cool,,line
731,coor,,line

711,mast,cool,wide      -subsidiary strings and widening
left side

711,mast,coor,wide      -subsidiary strings and widening
right
side

711                      -trigger 711
721,cool,,ic00,1,10=90 -annotate chainage
721,4=4
721,cool,,ic00,1,10=0  -annotate widening
721,4=-38
721,coor,,ic00,1,10=90 -annotate chainage
721,4=4
721,coor,,ic00,1,10=0  -annotate widening
721,4=-38
731,cool,,line

Dual CarriagewayDual Carriageway
    Specify reference string and box area
    -----
701,mast,,box2,,200,,560

    Specify subsidiary string and widening left side
    -----
    -reference string and box area
711,cmol,cool,wide

    Specify subsidiary string and widening right side
    -----
    -subsidiary strings and widening left side
711,cmor,coor,wide

    Trigger 711
    -----
    -subsidiary strings and widening right
side
711

    -trigger 711

```

```
721,cool,,ic00,1,10=90      -annotate chainage
721,4=4
    Annotate chainage of widening change points for
    left side
-----
721,cool,,ic00,1,10=90
    -annotate widening
721,4=-398

721,coor,,ic00,1,10=90     -annotate chainage
721,4=4
    Annotate chainage of widening change points for
    right side
-----
721,coor,,ic00,1,10=90
721,4=-39

    Annotate amount of widening for left side
-----
721,cool,,ic00,1,10=0
721,4=-38

    Annotate amount of widening for right side
-----
721,coor,,ic00,1,10=0
721,4=-38

    Annotate ordinates
-----
721,coor,,ic00,1,10=0     -annotate widening
721,4=-38
731,cool,,line
731,coor,,line
```

## Minor option 712 Vertical schematic line work (type 2)

Minor option 712 provides the facilities required to draw linework for a vertical schematic in an annotation box. Related option 722 annotates the schematic and 732 draws the ordinates.

### Input

### Graphics

This option is not available in graphics mode.



Linemode

Minor option 712

- Field 1      Geometry string
- Field 3      Annotation box name
- Field 4      Factor for length of gradient 'element' (x). If coded as negative, the length of gradient element is a fixed number of units.
- Fields 5 & 6   SPRD for start
- Field 7      Factor for height of gradient 'element' (y)
- Fields 8 & 9   SPRD for end
- Field 10     Factor for diameter of circle (z)

Example 1

- $a = l * x$       where x is between 0 and 1
- $b = h * y$       where y is between 0 and 1
- $c = h * z$       where c is between 0 and 1

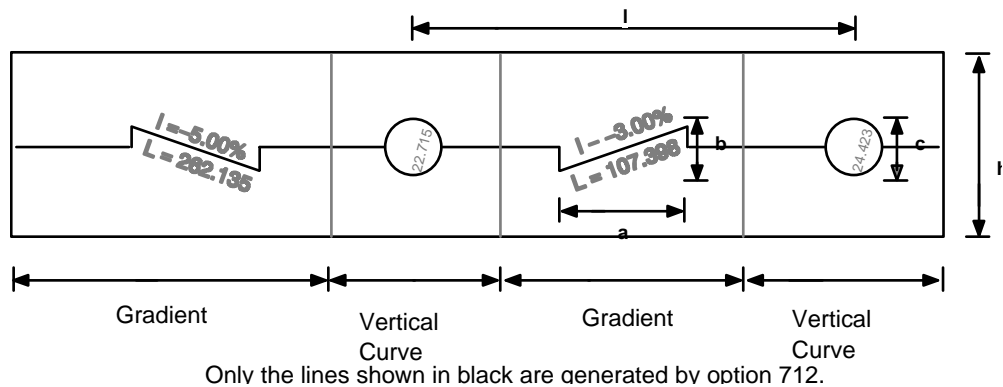


Figure 3 - 76    Example schematic type 2 linework

Minor option 722    Annotation of vertical schematic (type 2)

Minor option 722 provides the facilities required to annotate the vertical schematic, defined in minor option 712, with text. Related minor option 732 draws the ordinates.

Input

Graphics

This option is not available in graphics mode.

## Linemode

**First record**

## Minor option 722

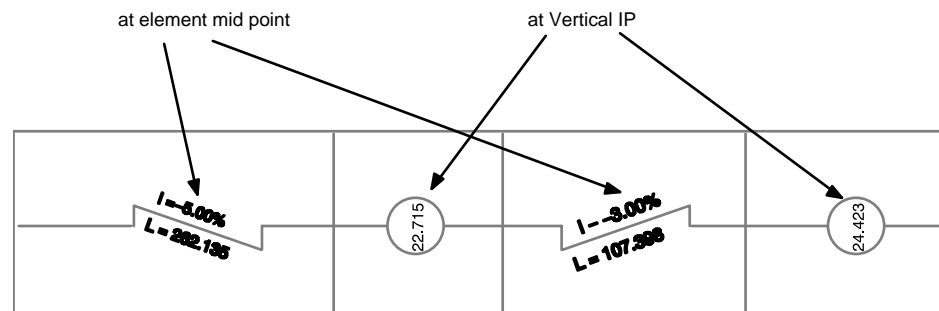
Field 1	Geometry string
Field 3	Increment and Decrement
Field 4	Text item position
	1 at element mid point
	2 at Vertical IP
Field 7	Text offset
	For text item position 1, text offset does not apply. The text can only be positioned at the element mid point.
Field 10	Rotation (about the centre of text)

**Subsequent records**

## Minor option 722

Field 3	Text variable name
Field 4	String dimension to be drawn.

◇ *This option must be followed by a 001 record.*



**Figure 3 - 77 Example schematic type 2 annotation**

**Minor option 732 Ordinates for vertical annotation (type 2)**

Minor option 732 provides the facilities required to draw the ordinates on the vertical schematic diagram defined in related minor options 712 and 722.

**Input****Graphics**

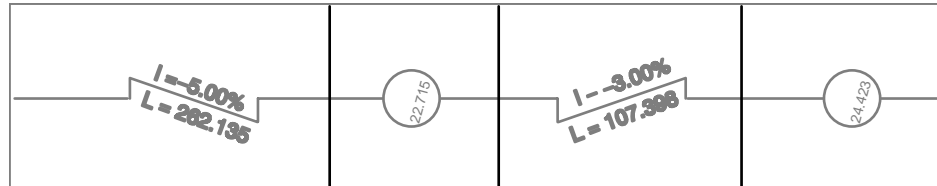
This option is not available in graphics mode.

Linemode

Minor option 732

Field 1 Geometry string label

◇ *If this option is omitted no ordinates will be drawn.*



Only the lines shown in black will be generated by option 732.

**Figure 3 - 78 Schematic type 2 ordinates- example 1**

Example 1

This will produce annotation as in Figure 3 - 78.

```

moss
draw, demo
900, longdraw
hs=500, vs=50, lb=mast, lr=mast

```

Set up box and text box width 3.0 cms

```

-----
810
805
845, BBL, BCPT, 1004, 9=-6.000, 3.0
845, BBL, CL, 3004, 6=-6.000, 6, 9=-6.000, 3.0
808, 4=0.4, 6=0.75
806
847*, 3=3004, 10=0
001VERTICAL
808

```

Set up line colour and style for Vertical schematic VLIN line and draw it

```

-----
805
806
809, VTPS
810
808

```

Specify Reference String for Vertical Schematic diagram

```

-----
712, GAST, V2AN, 1004, 0.5, 7=0.5, 10=0.35

```

Set up text colour and style

-----

806  
808  
806  
808

Annotate Gradient

-----

722,GAST,V2AN,I001,1  
722,3=GVTV,-23  
001,i =&GVTV&%

Annotate Gradient length

-----

722,GAST,V2AN,D002,1  
722,3=GLT2,-21  
001,L =&GLT2&m

Annotate VIP level

-----

722,GAST,V2AN,I000,2  
722,3=IPTV,3  
001,&IPTV&

Draw ordinates on diagram

-----

810  
805  
805  
732,GAST  
999

Example 2

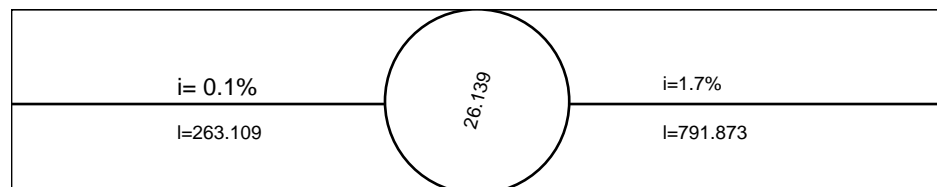


Figure 3 - 79 Schematic type 2 - example 2

moSS  
draw,demo  
900,longdraw

hs=500,vs=50,lb=mast,lr=mast

Set up box and text box width 3.0 cms

-----

810

805

845,BBL ,BCPT,1004,9=-6.000,3.0

845,BBL ,CL ,3004,6=-6.000,6,, -6.000,3.0

808,4=0.4,6=0.75

806

847\*,4=3004,10=0

001VERTICAL

808

Set up line colour and style for Vertical  
schematic VLIN line and draw it

-----

805

806

810

808

Specify Reference String for Vertical  
Schematic diagram

-----

712,GAST,,1004,0.0 ,7=0.0,10=1.0

Set up text colour and style

-----

806

808

806

808

Annotate Gradient

-----

722,GAST,,I001,1,10=0

722,3=GV2V,-23

001,i =&GV2V&%

Annotate Gradient length

-----

722,GAST,,D002,1,10=0

722,3=GL32,-21

001,L =&GL32&

Annotate VIP level

-----

722,GAST,I000,2,10=270

722, 3=IP2V, -50  
001, &IP2V&  
805  
806  
808  
810  
999

Example 3

To annotate in the style below, set Fields 4, 7 and 10 in 712 to 1 and include an 809 VIPS before the 712.

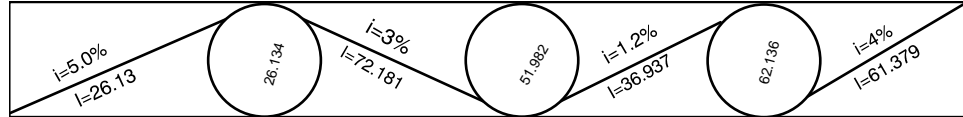


Figure 3 - 80 Schematic type 2 - example 3

```

moSS
draw,demo
900,longdraw
hs=500,vs=50,lb=mast,lr=mast

```

Set up box and text box width 3.0 cms

```

-----
810
805
845,BBL,,1004,9=-6.000,3.0
845,BBL,CL,3004,6=-6.000,6,9=-6.000,3.0
808,4=0.4,6=0.75
806
847*,3=3004,10=0
001VERTICAL
808

```

Set up line colour and style for Vertical schematic VLIN line and draw it

```

-----
805
806
810
805
000810,MACR,,,,
000810,DASH,,,,0.25,0.25,,0.25,0.25
808

```

Specify Reference String for Vertical Schematic diagram

```

-----
809VIPS
712,GAST,,1004,1.0,7=1.0,10=1.0

```

Set up text colour and style

```

-----
806
808

```

806  
808

Annotate Gradient

-----

722,GAST,,I001,1  
722,3=GV3V,-23  
001,i =&GV3V&%

Annotate Gradient length

-----

722,GAST,,D002,1  
722,3=GL23,-50  
001,L =GL23

Annotate VIP level

-----

722,GAST,,I000,2,10=270  
722,3=IP3V,-50  
001,&IP3V&  
805  
806  
808  
810  
999

### Minor option 713 Vertical schematic line work (type 3)

Minor option 713 provides the facilities required to draw linework for a vertical schematic on a profile drawing. Related option 723 annotates the schematic and 733 draws the ordinates.

#### Input

#### Graphics

This option is not available in graphics mode.

#### Linemode

##### Minor option 713

- Field 1 Reference string
- Field 3 Diagram style
  - 1 Diagram style 1. See Figure 3 - 81
  - 2 Diagram style 2. See Figure 3 - 82
  - 3 Diagram style 3. See Figure 3 - 81
- Field 4 Interval for intermediate annotation (Styles 1 and 3), commencing at first VTP.



Distance 'a' in Figure 3 - 83

For style 1, intermediate annotation commences at first VTP.

For style 3, intermediate annotation commences at first whole chainage after VTP.

Fields 5 & 6 SPRD for start

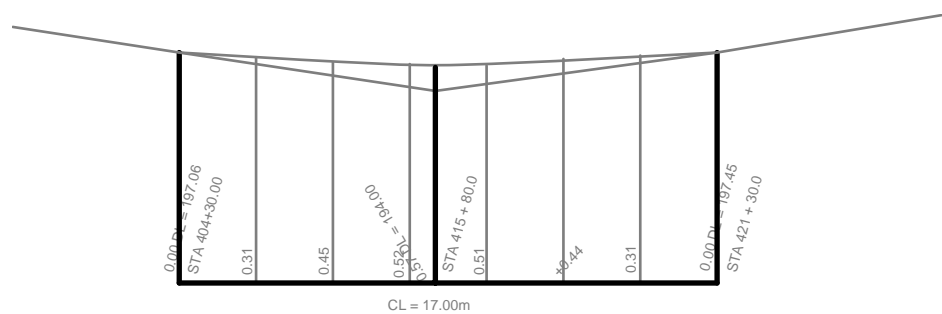
Field 7 Distance of diagram from VM point on string. (Model units)  
See also Field 10 and Figure 3 - 84.

Fields 8 & 9 SPRD for end

Field 10 Positive offset of diagram above section datum (Model units)

- ◇ *Field 10 is ignored if Field 7 is coded,*
- ◇ *The diagram will appear above or below the profile depending on the contents of Field 2 of minor option 809 (INOU or ONES). INOU will draw diagram and annotation above the profile for sag curves and below the profile for hog curves. See Figure 3 - 84.*
- ◇ *To draw just the VTPs and VIP ordinates, code a large interval in Field 4.*
- ◇ *The gradient annotation can be shown as percent or permille using the existing parameter file setting.*
- ◇ *Whole chainage is defined as the value that is a multiple of the interval for intermediate annotation. For example, if the chainage at the first VTP is 32.345 and the interval for intermediate annotation is 5 then the first whole chainage is 35.0. Similarly, if the chainage at the first VTP is 32.345 and the interval for intermediate annotation is 10 then the first whole chainage is 40.0.*

**Example 1**



Only the lines shown in black will be drawn by option 713

**Figure 3 - 81 Type 3 style 1 and 3**

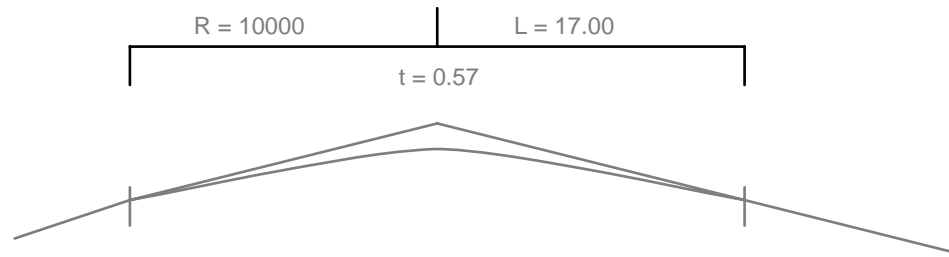


Figure 3 - 82 Type 3 style 2

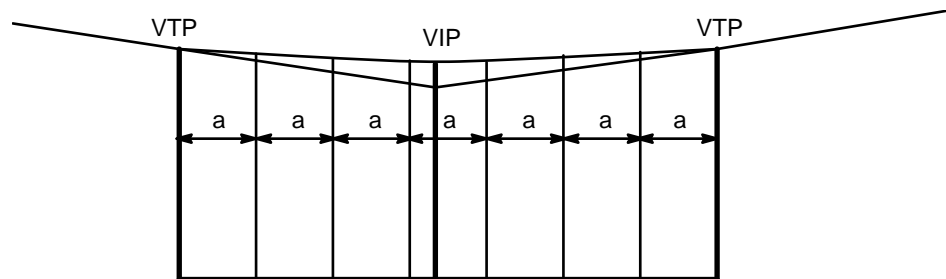


Figure 3 - 83 Intermediate annotation interval

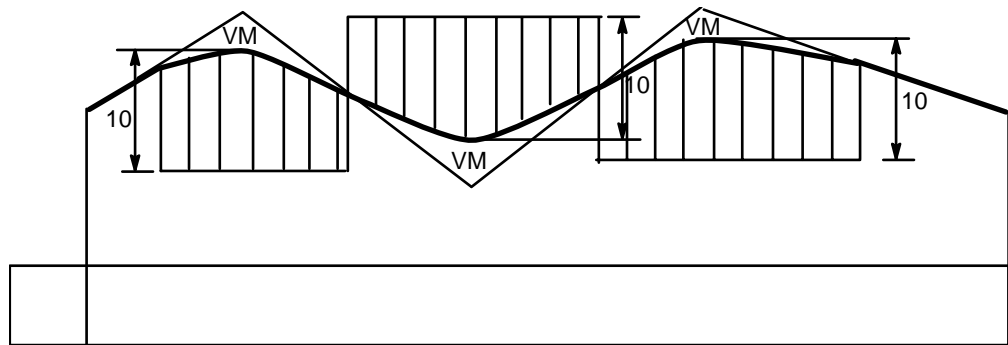


Figure 3 - 84 Offset of diagram from string

To draw the vertical curve diagram offset 10m above or below the string code:

809,, INOU

713,GAST,,1,5,7=10

## Minor option 723 Annotation for vertical schematic (type 3)

Minor option 723 provides the facilities required to annotate the vertical schematic, defined in minor option 713, with text. Related minor option 733 draws the ordinates.

### Input

### Graphics

This option is not available in graphics mode.

### Linemode

#### First record

##### Minor option 723

Field 1 Geometry string

Field 3 Increment and Decrement

Field 4 Text item position

if option 713 field 3 = 1 or 3 see Figure 3 - 85.

1 At curve mid point (ie centre of chord)

2 At VIP

3 At start VTP

4 At end VTP

5 At both VTPs and VIP

6 At intermediate points (see Minor option 713, Field 4)

if option 713 field 3 = 2 see Figure 3 - 86.

1 At curve mid point (ie centre of chord)

2 Between first VTP and VIP

3 Between VIP and last VTP

Field 7 Text offset

◇ *For text item position 1, text offset does not apply. The text can only be positioned at the mid point of the curve.*

Field 10 Rotation (about the centre of text)

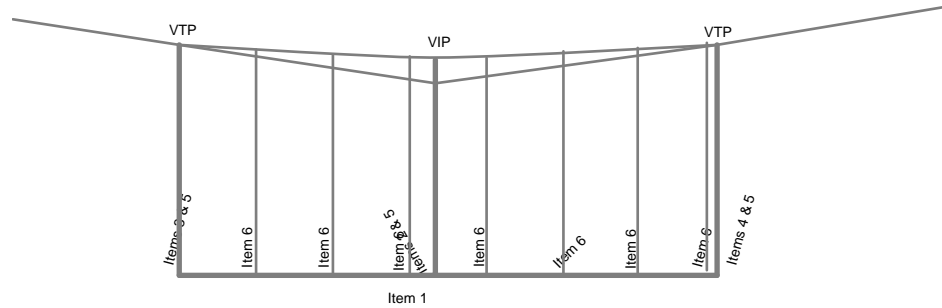
#### Subsequent records

##### Minor option 723

Field 3 Text variable name

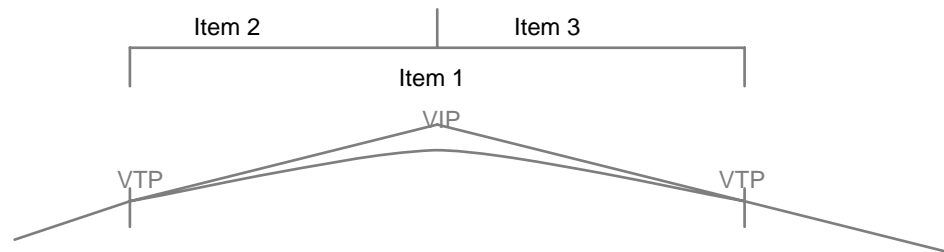
Field 4 String dimension to be drawn.

◇ *This option must be followed by a 001 record.*



Only the text shown in black will be drawn by option 723.

Figure 3 - 85 Vertical schematic text item positions - style 1



Only the text shown in black will be drawn by option 723.

Figure 3 - 86 Vertical schematic text item positions - style 2

### Minor option 733 Ordinate for annotation (type 3)

Minor option 733 provides the facilities required to draw the ordinates on the vertical schematic diagram defined in related minor options 713 and 723.

#### Input

#### Graphics

This option is not available in graphics mode.

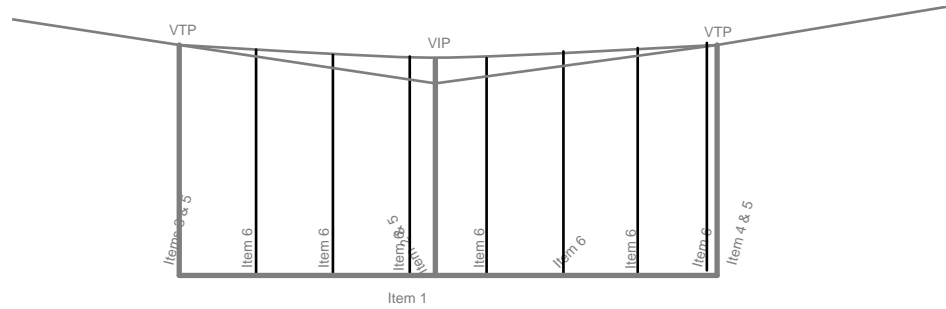
#### Linemode

#### Minor option 733

Field 1 Geometry string label

◇ *If this option is omitted the intermediate ordinates will be omitted.*

Example 1



Only the lines shown in black will be drawn by option 733.

**Figure 3 - 87 Vertical schematic type 3 showing ordinates**

```

moos
draw,demo
900,longdraw
hs=250,vs=25,lb=mast,lr=mast,sf=vs
805
806
808
806
808
809,,inou
810
    Set up line colour and style line work at VIP
    and VTPs and draw it
    -----
000810,DASH,,,,0.25,0.25,,0.25,0.25
805,gree
713,GAST,3=1,5,7=4

    Draw ordinates at intermediate points using
    above line style and colour
    -----
733,GAST

    Set up text colour and style
    -----
805
806,gree
808,4=0.35
810

    Text for curve length annotation at curve
    mid point
    -----
723,GAST,,D001,1,10=90
    
```

723,3=TVA1,-21  
001,CL =&TVA1&m

Text for level annotation at VTPs & VIPs

-----  
723,GAST,,I000,5,7=2.5,10=0  
723,3=TVA2,3  
001,DL =&TVA2&m

Text for chainage annotation at VTPs & VIPs

-----  
723,GAST,,D001,5,7=0,10=0  
723,3=TVA3,4  
001,Sta &TVA3&

Text for curve to tangent distance annotation  
at intermediate points

-----  
723,GAST,,I000,6,7=0,10=0  
723,3=TVA4,-52  
001,&TVA4&

Text for curve to tangent distance annotation at  
VTPs & VIPs

-----  
723,GAST,,I000,5,7=0,10=0  
723,3=TVA5,-52  
001,&TVA5&  
999

## Minor option 714 Vertical schematic linework (type 4)

Minor option 714 provides the facilities required to draw circular linework for a vertical schematic. Related option 724 annotates the schematic and 734 draws the ordinates.

### Input

#### Graphics

This option is not available in graphics mode.

#### Linemode

##### Minor option 714

Field 1	Reference string
Field 3	Annotation area name
Fields 5 & 6	SPRD for start
Field 7	Factor for diameter of circle (x)
Fields 8 & 9	SPRD for end
Field 10	Factor for diameter of symbol (y)

#### Example 1

$a = h * x$  where x is between 0 and 1  
 $b = h * y$  where y is between 0 and 1

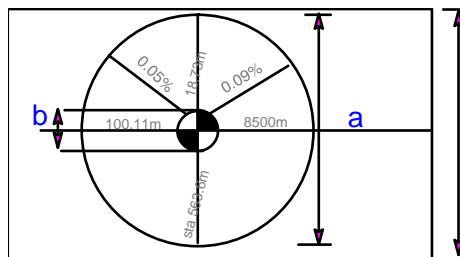
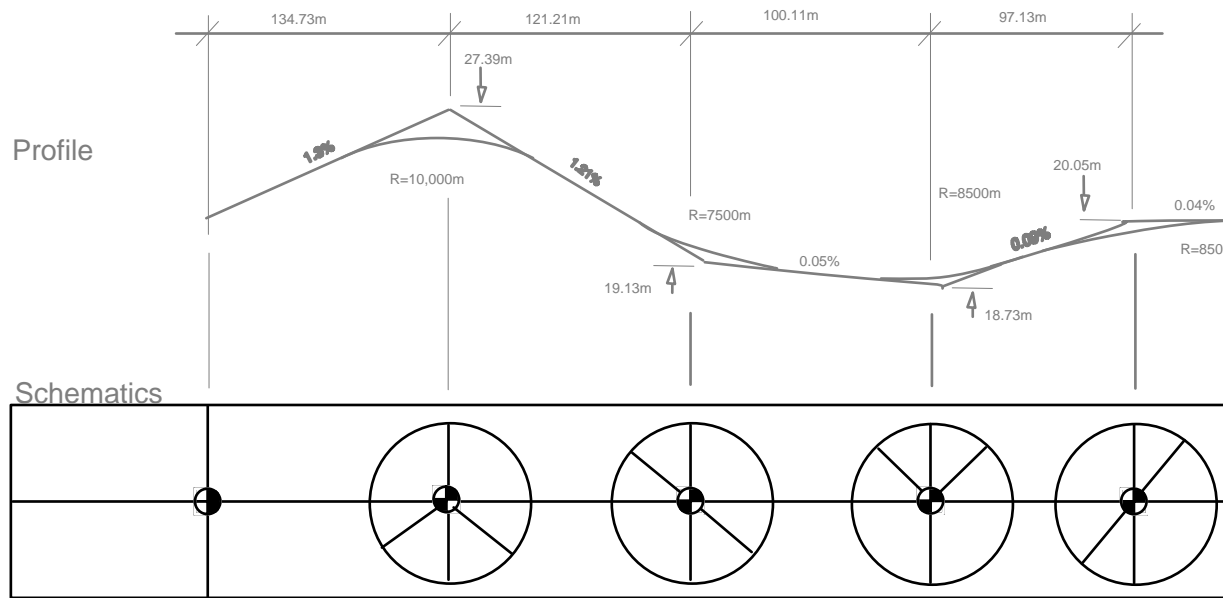


Figure 3 - 88 Example showing vertical schematic linework dimensions



Only the lines shown in black are defined by option 714

Figure 3 - 89 Example showing vertical schematic linework

### Minor option 724 Annotation for circular schematic (type 4)

Minor option 724 provides the facilities required to annotate the circular schematic, defined in minor option 714, with text. Related minor option 734 draws the key diagram.

#### Input

#### Graphics

This option is not available in graphics mode.

#### Linemode

#### First record

#### Minor option 724

- Field 1 Reference string
- Field 3 Increment and Decrement
- Field 4 Text item position  
(item 1-6, see Figure 3 - 90)



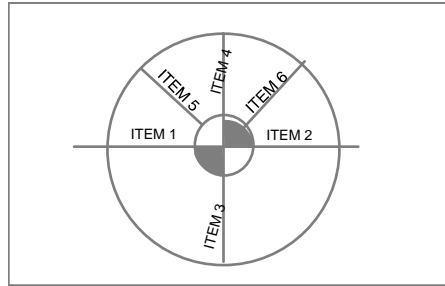


Figure 3 - 90 Example showing annotation locations

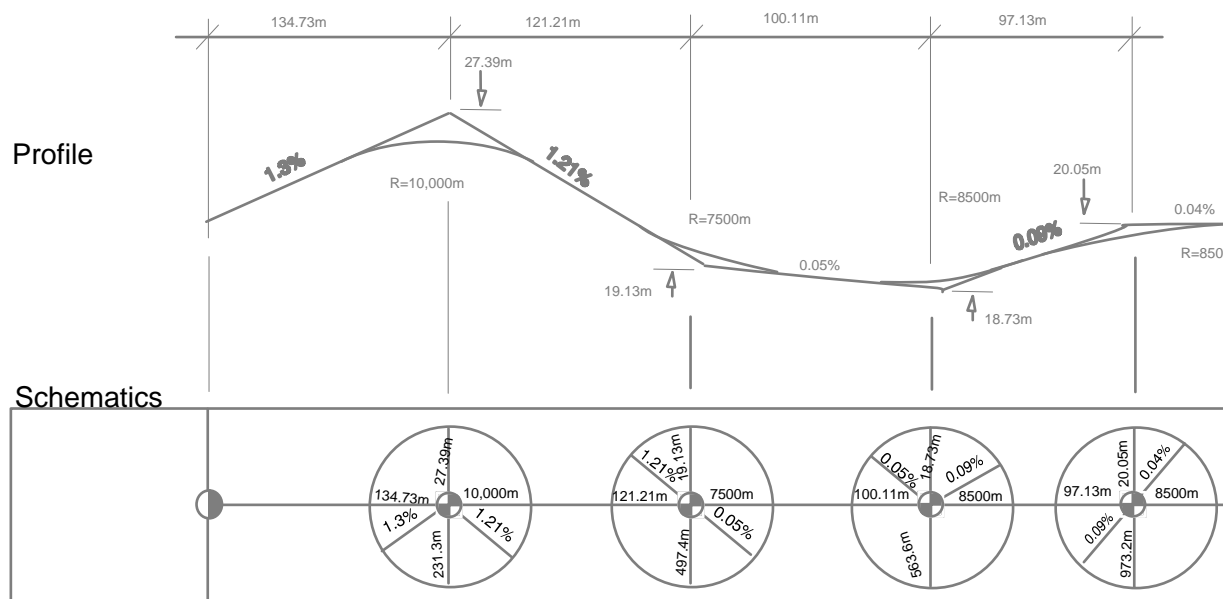
**Subsequent records**

Minor option 724

Field 3 Text variable name

Field 4 String dimension to be drawn.

◇ This option must be followed by a 001 record.



Only the text shown in black is drawn by option 724

Figure 3 - 91 Example of type 4 annotation

**Minor option 734 Key diagram for circular schematic (type 4)**

Minor option 734 provides the facilities required to draw and annotate the key diagram on the vertical schematic diagram defined in related minor options 714 and 724.

Input

Graphics

This option is not available in graphics mode.

Linemode

First record

Minor option 734

Field 3 Annotation area name (from 845)

Field 7 Factor for diameter of circle (x) (optional)

Field 10 Factor for diameter of symbol (y) (optional)

◇ The circle and symbol size will be the same as defined in minor option 714 if Fields 7 and 10 are omitted.

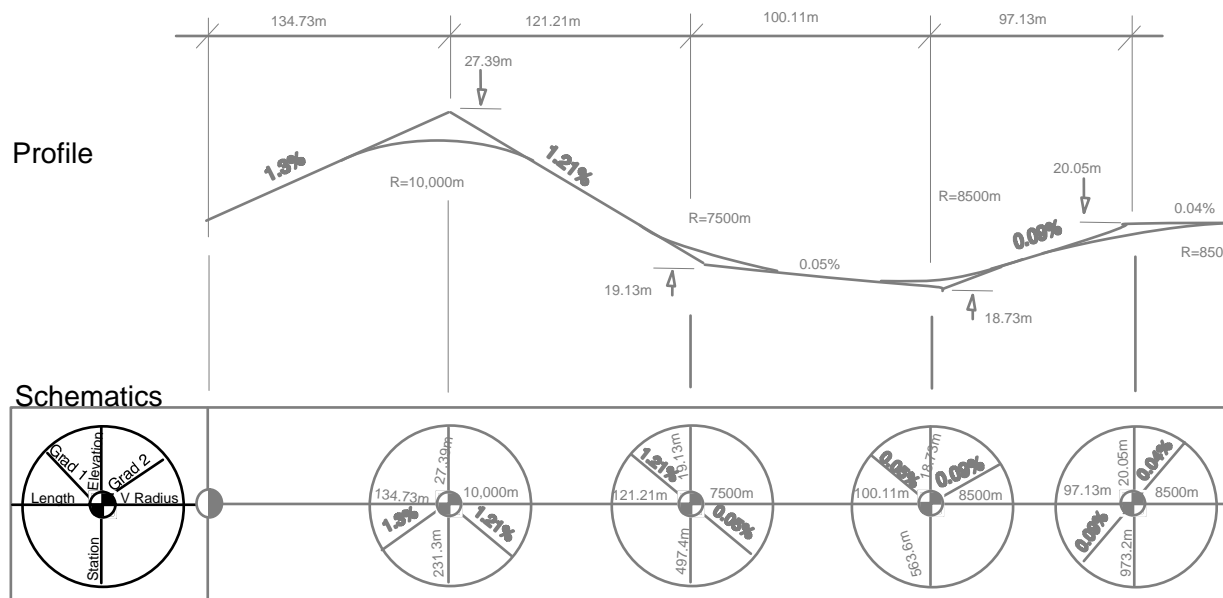
Subsequent records

Minor option 734

Field 4 Text item position. See Figure 3 - 90

◇ This option will be followed by as many 001 records as are necessary to define the text for each text item.

Example 1



Only the key lines and text shown in black are drawn by option 734

Figure 3 - 92 Example of type 4 key diagram

```

moos
draw, demo
900, longdraw
hs=1000, vs=100, lb=mast, lr=mast

```

Set up box and text box width 3.0 cms

-----

810  
805  
845,BBL ,BCPT,1004,9=-6.000,3.0  
845,BBL ,CL ,KEYJ,6=-6.000,6,9=-6.000,3.0  
808,4=0.4,6=0.75  
808

Set up line colour and style for Vertical  
schematic CENT line and draw it

-----

805  
806  
810  
805  
810,DASH,5=0.25,0.25,,0.25,0.25  
805,CENT,LC  
701,GAST,,1004  
711,3=CENT

Set up line colour and style for Vertical  
schematic VLIN line and draw it

-----

805  
806  
810  
805  
000810,MACR,,,,  
000810,DASH,,,,0.25,0.25,,0.25,0.25

Specify Reference String for Vertical Schematic  
diagram

-----

714,GAST,V3AN,1004,7=0.9,10=0.25

Set up text colour and style

-----

806  
808  
806  
808,4=0.08

Annotate Text Item 1 (Default = Length between  
VIPs, -21)

-----

809,VIPS  
724,GAST,4=V3AN,1  
724,3=I1TV,-21

001,L=&I1TV&m  
809

Annotate Text Item 2 (Default = Vertical Curve  
Radius, -53)

-----  
809,VIPS  
724,GAST,4=V3AN,2  
724,3=I2TV,-53  
001,R=&I2TV&m  
809

Annotate Text Item 3 (Default = Chainage of VIP,  
4)

-----  
809,VIPS  
724,GAST,4=V3AN,3  
724,3=I3TV,4  
001,Sta &I3TV&m  
809

Annotate Text Item 4 (Default = Level of VIP, 3)

-----  
809,VIPS  
724,GAST,4=V3AN,4  
724,3=I4TV,3  
001,El=&I4TV&m  
809

Annotate Text Item 5 (Default = Gradient before  
VIP, -65)

-----  
809,VIPS  
724,GAST,4=V3AN,5  
724,3=I5TV,-65  
001,i=&I5TV&%  
809

Annotate Text Item 6 (Default = Gradient afterbefore  
VIP, -66)

-----  
809,VIPS  
724,GAST,4=V3AN,6  
724,3=I6TV,-66  
001,i=&I6TV&%  
809

Draw Key diagram

-----  
000845, BL,,KEYJ,,,-4.5,3.0,, -6.0,3.0

734,3=KEYJ

In 734 above note that as fields 7 & 10 are not coded, the symbol and circle are defined @ 714 714 above.

734,4=1

001,Length

734,4=2

001,V Radius

734,4=3

001,Station

734,4=4

001,Elevation

734,4=5

001,Grad 1

734,4=6

001,Grad 2

999

## Minor option 800 Define sheet details

Defines the drawing layout, with details such as sheet orientation and sheet size. Sheet orientation may be portrait or landscape. Sheet size may be specified as a standard A or B series paper size, a multiple of a standard size, or using any user defined dimensions.

For details of how to set margins for the sheet, refer to minor option 802, 'Define sheet margins'.

### Standard paper sizes

The following table lists the dimensions of the standard A and B series paper sizes:

Paper size	Metric dimensions (cms)	Imperial dimensions (inches)
A0	84.1 x 118.9	33.11 x 46.81
A1	59.4 x 84.1	23.39 x 33.11
A2	42.0 x 59.4	16.54 x 23.39
A3	29.7 x 42.0	11.69 x 16.54
A4	21.0 x 29.7	8.27 x 11.69
A5	14.8 x 21.0	5.83 x 8.27
A6	10.5 x 14.8	4.13 x 5.83
A7	7.4 x 10.5	2.91 x 4.13
B0	100.0 x 141.4	39.37 x 55.67
B1	70.7 x 100.0	27.83 x 39.37
B2	50.0 x 70.7	19.69 x 27.83
B3	35.3 x 50.0	13.90 x 19.69
B4	25.0 x 35.3	9.84 x 13.90
B5	17.6 x 25.0	6.93 x 9.84

B6	12.5 x 17.6	4.92 x 6.93
----	-------------	-------------

Input

Graphics

IGDRAWT.DAT, DRW004, DRW002, DRW040

DRAW - Option details	Sheet details	Sheet size
Model for DRAW	Sheet orientation	Sheet orientation (T)
Draw all strings	Sheet size	Sheet type indicator (T)
Draw all strings (DETA)	Sheet length Sheet width	Sheet size - A type
Draw selected strings	Constant margin	Sheet size - B type
Draw raster backcloth	Margins L B	Sheet length
Draw using a macro	R T	Multiple of sheet length
Define a boundary	Scale Truncation	Sheet width
Create new sheet	Origin X Y	Multiple of sheet width
Add drawing details	Bearing of left hand side	
End DRAW		

In IGmode, the drawing sheet details are only invoked when creating a new sheet or drawing in an empty DPF via DRAW - Contract Drawings.

If a DPF is displayed before a new sheet is created you will be asked to take the existing details as a starting point. That is, to use the same margins, scale etc as listed above. If so, these are then displayed allowing you to modify them as required.

Linemode

Minor option 800

- Field 1 Sheet orientation
  - LAND landscape orientation (default)
  - PORT portrait orientation
- Field 4 Sheet size
  - 0 sheet size is defined by the size and scale of the model.
  - 1 sheet size is coded in fields 5 and/or 6.

- ◇ *Field 1 is ignored if you specify the sheet length and width by units.*
- ◇ *The default sheet orientation can be changed using the parameter DPAPORIN in the parameter file.*
- ◇ *A value of 0 in Field 4 defines a sheet of infinite size therefore 803,3 = TRUN must also be coded to truncate the sheet.*

**Specification by units**

- Field 5 Sheet length in current linear measure units
- Field 6 Sheet width in current linear measure units
- Field 8 X magnification factor
- Field 9 Y magnification factor

**Specification by A size**

- Field 5 A size. eg 3 would give an A3 size sheet
- Field 7 Multiple of sheet length
- Field 8 X magnification factor
- Field 9 Y magnification factor
- Field 10 Multiple of sheet width

**Specification by B size**

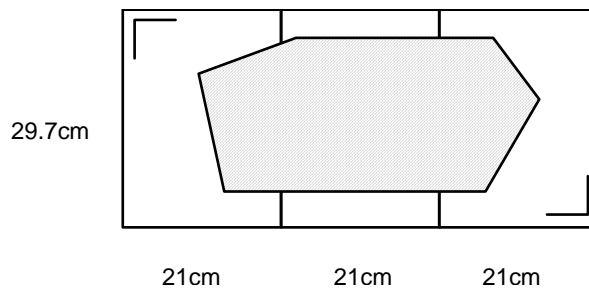
- Field 6 B size no. eg 3 would give a B3 size sheet
- Field 7 Multiple of sheet length
- Field 8 X magnification factor
- Field 9 Y magnification factor
- Field 10 Multiple of sheet width

- ◇ *Note these factors will only be applied when converting to a plot file.*
- ◇ *For details of how to specify margins, refer to minor option 802, 'Define sheet margins'.*

**Example 1**

This example sets up a sheet size of 3 A4 sheets in portrait orientation. A constant margin of 1cm is specified.

```
DRAW, SIMPLE EXAMPLE
800, PORT, 4=1, 4, 7=3
802, 4=1
803, 7=500
```



**Figure 3 - 93 Multiple sheets in portrait orientation**

Example 2

This example sets up a sheet size of 2 x 2 A4 sheets in landscape orientation. A constant margin of 1cm is specified.

```

DRAW, SIMPLE EXAMPLE
800, LAND, 4=1, 4, 7=2, 10=2
802, 4=1
803, 7=500
    
```

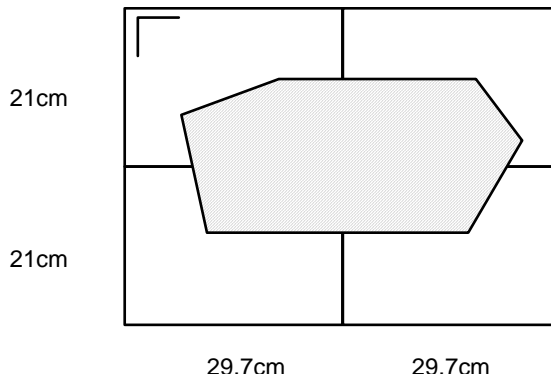


Figure 3 - 94 Multiple sheets in landscape orientation

Minor option 801 Invoke overplotting

Invoke overplotting, so adding another picture to the DPF.

Drawings may be superimposed on one another in two distinct ways. First when the contents of two or more models are to be combined on the same drawing and secondly when different parts of the same model are to be drawn in different ways, for example different strings in different colours. Minor option 801 achieves the first of these alternatives.

If DRAW is entered a second time, use of 801 will force the drawn information to be overlaid on the previous drawing. If it is omitted a new set of drawings is produced. Note that where a new set of information is to be overplotted on existing information the same origin will be used. Where the effective drawing origin is to be moved as in the case of composite drawings showing a plan in the lower half of the drawing and a long section in the upper half, the drawing windows should be redefined by adjusting margins, as defined on option 802.



When to use minor options 800/801/802 for overplotting

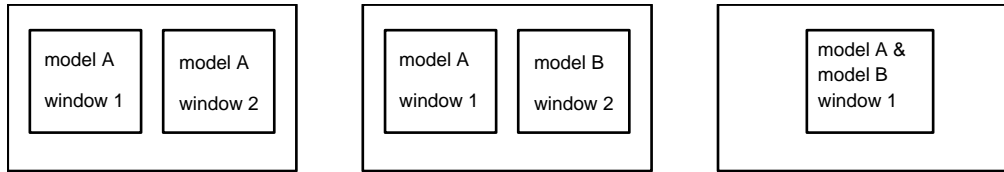


Figure 3 - 95 Examples - overplotting

SAME MODEL - DIFFERENT WINDOWS	DIFFERENT MODELS - DIFFERENT WINDOWS	DIFFERENT MODELS - SAME WINDOW
DRAW,MODEL A	DRAW,MODEL A	DRAW,MODEL A
800 - OPTIONAL	800 - OPTIONAL	800 - OPTIONAL
802 - DEFINE WINDOW 1	802 - DEFINE WINDOW 1	802 - DEFINE WINDOW 1
.	.	.
.	.	.
802 - DEFINE WINDOW 2	DRAW,MODEL B	DRAW,MODEL B
	800 - MUST NOT OCCUR	800 - MUST NOT OCCUR
.	801 - ESSENTIAL	801 - ESSENTIAL
.	802 - DEFINE WINDOW 2	802 - UNNECESSARY
.	.	.
.	.	.
.	.	.

Input

Graphics

Overplotting is an automatic feature, so minor option 801 cannot be user defined and composite drawings cannot be created.

Linemode

Overplotting

Minor option 801

Field 1 OVER

Major option DRAW may be followed by option 800 or 801,OVER or neither, but not both. Within any one entry to DRAW all strings are drawn in the currently defined window, without any need to consciously request overplotting.

Adding another picture to the DPF

To produce a set of drawings independent of those already stored on the DPF (Drawing Picture File) a 'new page' feature may be invoked. In practice this adds the new drawing to the DPF as a new set of sheets whilst retaining the first set.

Adding a new page is invoked using option 801 and coding 'NEWP' instead of 'OVER', but **801,NEWP must be the first minor option after the major option record.**

In these circumstances (and these circumstances alone) minor option 800 may follow the initial 801 record.

## Input

### New page

#### Minor option 801

Field 1        NEWP

This record must be the first minor option encountered after the major option record and it can be followed by an option 800.

## Examples

### 1. Acceptable

```
DRAW,SIMPLE DESIGN GROUND
  Generate a single drawing.
800
.
.
.
999
```

### 2. Acceptable

```
DRAW, SIMPLE DESIGN GROUND
  Generate a single drawing.
800
.
.
.
999
DRAW, SIMPLE DESIGN ROAD
  Add an independent drawing.
801,NEWP
800
.
.
999
```

### 3. Acceptable

```
DRAW, SIMPLE DESIGN GROUND
  Generate a single drawing.
800
.
.
.
999
DRAW,SIMPLE DESIGN ROAD
  Overplot the Road on top of the ground.
801,OVER
.
.
.
999
```

4. Not Acceptable

DRAW,SIMPLE DESIGN GROUND  
800  
.  
.  
801,OVER  
Because within 1 call to DRAW all elements are  
overdrawn.  
999

5. Not Acceptable

DRAW,SIMPLE DESIGN GROUND  
800  
.  
.  
.  
801,NEWP  
because within 1 call to DRAW all elements are  
overdrawn.  
999

Used in conjunction with major option DISPLAY a useful range of drawing alternatives become available.

6. Series of Drawing independently created, immediately checked and not needed to be stored.

DRAW,SIMPLE DESIGN GROUND  
.  
.  
.  
999  
DISPLAY  
DRAW,SIMPLE DESIGN ROAD  
.  
.  
.  
999  
DISPLAY  
DRAW,SIMPLE DESIGN CONTOURS  
.  
.  
.  
999  
DISPLAY

7. Series of Drawings checked at different stages of development but building up one drawing only.

DRAW, SIMPLE DESIGN GROUND  
.  
.  
.  
999  
DISPLAY  
DRAW, SIMPLE DESIGN ROAD  
801,OVER  
.  
.  
.  
999

DISPLAY  
DRAW, SIMPLE DESIGN CONTOURS  
801, OVER

.  
. .  
999  
DISPLAY

**8. Series of Drawings independently created but all stored.**

DRAW, SIMPLE DESIGN GROUND

.  
. .  
999

DRAW, SIMPLE DESIGN ROAD  
801, NEWP

.  
. .  
999

DRAW, SIMPLE DESIGN CONTOURS  
801, NEWP

.  
. .  
999

DISPLAY

**9. Combination of 7 and 8 above.**

DRAW, SIMPLE DESIGN GROUND  
800

.  
. .  
999

DISPLAY  
DRAW, SIMPLE DESIGN ROAD  
801, OVER

.  
. .  
999

DISPLAY  
DRAW, SIMPLE DESIGN CONTOURS  
801, NEWP  
800

.  
. .  
999

DISPLAY

◇ *In examples 6 - 9 it is not strictly necessary to preview each stage of the drawing and elimination of DISPLAY from the above examples would not change the sense.*

## Create new sheet

This option is only available if entry to DRAW used the DRAW - contract drawing option.

The option allows you to replace the current DPF or add an additional sheet to the current DPF.

This option is only available in graphics.

'Create new sheet' is only available in graphics and is used to define sheet details. For further information, refer to minor option 800 'Define sheet details'.

### Input

### Graphics

IGDRAWT.DAT, DRW004, DRW035

DRAW - Option details	Create new sheet
Model for DRAW	Overwrite DPF
Draw all strings	Append sheet to DPF
Draw all strings (DETA)	
Draw selected strings	
Draw raster backcloth	
Draw using a macro	
Define a boundary	
Add drawing details	
Create new sheet	
End DRAW	

**Overwrite dpf:** selecting this option will prompt  
Extract sheet details from existing picture?  
(Y/N/Q default = N)  
if you select N the following menu will be displayed.

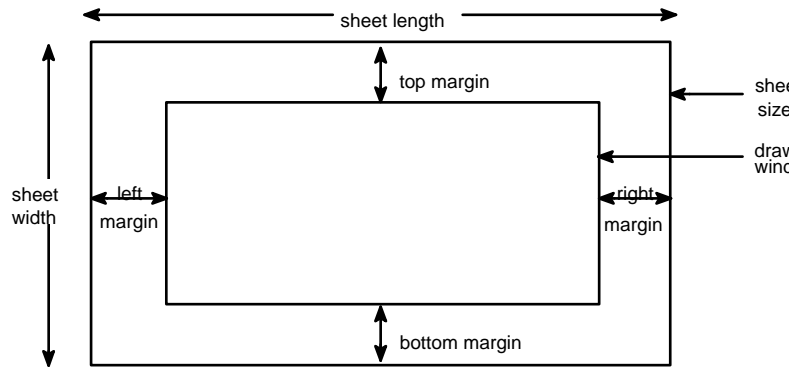
IGDRAWT.DAT, DRW002

**Append sheet to dpf:** allows you to add the currently displayed sheet to the dpf and causes display of the DRAW - option details menu to exit or create another new sheet.

## Minor option 802 Define sheet margins

Define sheet layout, drawing windows and margins.

If omitted the installation default will be used.



**Figure 3 - 96 Sheet details**

**Input**

Graphics

IGDRAWT.DAT, DRW004, DRW002, DRW002

DRAW - Option details	Sheet details
Model for DRAW	Sheet orientation
Draw all strings	Sheet size
Draw all strings (DETA)	Sheet length
Draw selected strings	Sheet width
Draw raster backcloth	Constant margin
Draw using a macro	Margins L
Define a boundary	B
Create new sheet	R
Add drawing details	T
End DRAW	Scale
	Truncation
	Origin X
	Y
	Bearing of left hand side

Sheet margins are defined when creating a new sheet, or drawing in an empty DPF (Drawing Picture File).

The margins can be specified individually, or a constant margin can be applied.

## Linemode

### Plan drawings

Field 4      Constant margin width in current linear measure units

Or:-

Field 5      Left margin width in current linear measure units

Field 6      Bottom margin width in current linear measure units

Field 8      Right margin width in current linear measure units

Field 9      Top margin width in current linear measure units

### Automatic placement of sections

◇ *Fields 1,2,3,7 and 10 are only relevant for cross sections.*

#### Minor option 802

Field 1      UP if first section to be drawn in bottom left window with successive section moving upwards  
DOWN if first section to be drawn in top left window with successive sections moving downwards  
Alternatively columns 1, 2 and 3 of this field may be used individually to specify the layout of the sections as follows:

Column 1

U      Up. As above (default if omitted)  
D      Down. As above

Column 2

L      Left justify sections in each column  
C      Centre sections in each column around their origins (default if omitted)  
R      Right justify sections in each column.

Column 3

A      Align each row of sections along a common base line  
S      Space the sections in each row according to the value in field 10 (default if omitted).

Field 2      Number of rows of windows to be drawn, coded as a right justified integer

Field 3      Number of columns of windows to be drawn, coded as a right justified integer

Field 7      Intermediate horizontal spacing in current linear measure units if omitted margin width assumed

Field 10     Intermediate vertical spacing in current linear measure units if omitted margin width assumed

To specify the margins, use Fields 4, 5, 6, 8 and 9 as for plan drawings.

**Manual placement of sections**

First record:

Minor option 802

Field 1 MARG

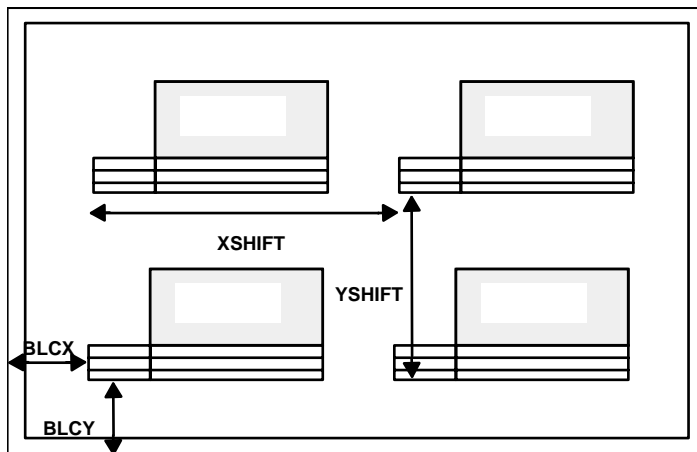
To specify the margins, use Fields 4, 5, 6, 8 and 9 as for plan drawings.

Second record:

Minor option 802

◇ *Fields 1,2,3,7 and 10 are only relevant for cross sections.*

- Field 1 (See Field 1 of 'Automatic placement of sections')
- Field 2 Number of rows of windows to be drawn, coded as a right justified integer
- Field 3 Number of columns of windows to be drawn, coded as a right justified integer
- Field 5 X coordinate of bottom left hand corner (BLCX)
- Field 7 X offset of next section (XSHIFT)
- Field 8 Y coordinate of bottom left hand corner (BLCY)
- Field 10 Y offset of next section (YSHIFT)



**Figure 3 - 97 Manual placement of sections**

**Examples**

Create a margin twice as wide on the sides, as on the top and bottom. For a plan view.

802, 5=4, 2, , 4, 2

Draw a series of cross sections increasing in chainage down the sheet; right justify the sections in the area to contain them; and align the sections horizontally regardless of the space created on the sheet.

802, DRA, 7=5



## Minor option 803 Define coordinate relationship

Defines the relationship between the model and drawing coordinate systems.

Before a drawing can be produced, it is necessary to define the relationship between the drawing coordinate system (x,y) where x and y coincide with the bottom and left hand side of the drawing window and the model coordinate system. It is also necessary to define the action to be taken if the drawn information extends beyond the window or vice versa.

### Plan drawing

First the origin of the drawing window ( $XL = 0, YL = 0$ ) is defined in the model coordinate system. Then the drawing window is rotated about the origin in a clockwise direction. Finally the scale is defined.

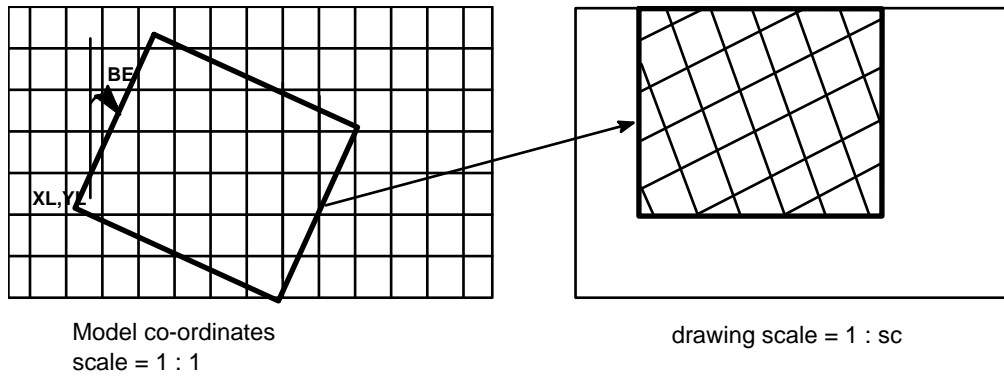


Figure 3 - 98 Example - plan drawing

Input

Graphics

DRW004,DRW002,DRW002

DRAW - Option details	Sheet details	Sheet details
Model for DRAW	Sheet size	Truncate
Draw all strings	Constant marg	Origin X
Draw all strings (DETA)	Sheet length	Y
Draw selected strings	Sheet width	Bearing of left hand side
Draw raster backcloth	Margins B	
Draw using a macro	L	
Define a boundary	T	
Add drawing details	R	
Create new sheet	Scale	
End DRAW	Truncate	

The coordinate relationship is defined when creating a new sheet, or drawing in an empty DPF (Drawing Picture File).

Linemode

Plan drawing

Minor option 803

- Field 1      PLAN
- Field 2      PAGE to invoke automatic paging.  
NOPA to produce one page only.
- Field 3      TRUN for each window to be truncated at the top and  
righthand side.  
NOTR to maintain the window size.
- Field 4      Angle of rotation of left hand side of drawing clockwise relative  
to due north.
- Field 5 & 6    Model coordinates of bottom left window.
- Field 7      Scale of drawing (ie 500 for 1:500)

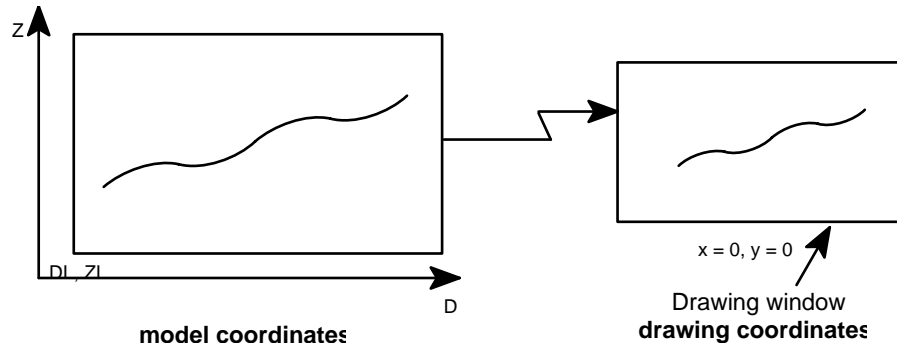
◇ *If fields 5 and/or field 6 are omitted the major option will determine these values from the minimum coordinates of the model data to be drawn.*

Example

803 , PLAN , 4=45.0 , 18500 , 19000 , 500.0

## Long section drawing

For long sections the model coordinate system is (D,z) where D is longitudinal distance and z is absolute height. The longitudinal axis can either be a straight line in plan defined by a pair of x,y coordinates or any string. All other strings are projected onto this axis.



**Figure 3 - 99 Example - relationship of model and drawing coordinates**

First the origin of the axis ( $x = 0, y = 0$ ) is defined in the model coordinate system (D, Z). The distance origin is either defined as an absolute value  $D_0$  or as a displacement relative to the distance value of the leftmost point of the first string plotted. The height origin is defined either as an absolute value  $Z_0$  or as a displacement relative to the lowest point encountered in all of the strings to be plotted - this method ensures a separation between the lowest string point and the horizontal axis. Finally the horizontal (distance) and vertical scales are defined.

Once the line or string representing the longitudinal axis has been defined any other string is drawn as a projection onto that axis.

**Input****Long section drawing****Minor option 803**

- Field 1        LONG to draw long section.  
LCRP to crop top of section according to value entered in Field 4. This facility allows the upper part of profiles to be truncated when insufficient space is available for plotting.
- Field 2        PAGE to invoke automatic paging.  
NOPA to produce one page only.
- Field 3        TRUN for each window to be truncated at the top and right hand side.  
NOTR to maintain the window size.
- Field 4        Positive value - displacement from highest string point to top of section window in model units.  
Negative value - maximum level displayed in the section window in model units.  
If LCRP selected in Field 1, enter desired height of section area in model units measured from profile datum.

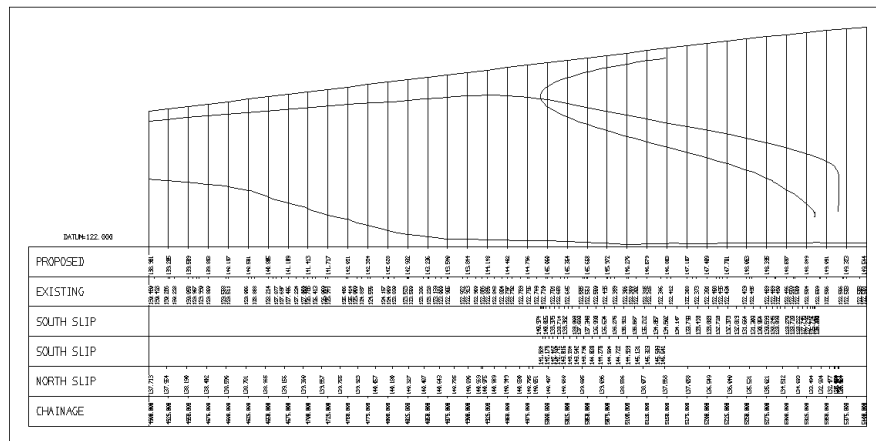
A number of alternatives is provided.

1. Specification of origin in absolute model units.

- \* Field 5        Origin of horizontal axis in model units.
- Field 7        Horizontal Scale.
- Field 8        Origin of vertical axis in model units.
- Field 10       Vertical Scale

2. Specification of origin in displacement model units.

- Field 6        Displacement from leftmost string point to the vertical axis. (X0)
- Field 7        Horizontal scale.
- Field 9        Positive value - displacement from lowest string point to the horizontal axis, referred to as the minimum actual level difference. (Y0). The resultant datum level is rounded down.  
Negative value - the nearest multiple of the given value below the lowest string point.
- \* Field 10       Vertical scale.



**Figure 3 - 100 Long sections relative to M003**

**Cross section drawing**

For a cross section the model coordinate system is (0,z) where 0 is the offset relative to a datum line or string that was used to generate the section and z is the absolute level. Each cross section may be considered as a mini drawing and for each ‘mini-drawing’ a different horizontal relationship between the model and drawing coordinate systems will apply. Thus only the scales and level datum are defined.

**Manual setting of drawing scales**

With the manual setting of drawing scales, you specify a single horizontal and vertical scale for the drawing of cross sections.

**Input**

Linemode

**Cross section drawing (manual setting)**

**Minor option 803**

Field 1 CROS

Field 2 PAGE to invoke automatic paging.  
NOPA to produce one page only.

Field 3 TRUN for each window to be truncated at the top and righthand side.  
NOTR to restrict truncation.

Field 4 Positive value - displacement from highest string point to top of section window in model units.  
Negative value - maximum level displayed in the section window in model units.

A number of alternatives is provided.

1. Specification of origin in absolute model units.
  - \* Field 7      Horizontal scale.
  - Field 8      Origin of vertical axis in model units. (Absolute level datum).
  - \* Field 10     Vertical scale.
2. Specification of origin in displacement model units.
  - \* Field 7      Horizontal scale.
  - Field 9      Positive value - displacement from lowest string point to the horizontal axis. The resultant datum level is rounded down. Negative value - the nearest multiple of the given value below the lowest string point.
  - \* Field 10     Vertical scale.

**Example**

803 , CROS , 7=500 , 10=50 , 9=5 . 0

**Automatic setting of drawing scales**

You may specify a series of drawing scales so that individual cross sections are automatically sized to fit on a fixed sheet size. The drawing scales are specified using additional 803 records, while the sheet size is specified in a previous minor option 800.

An attempt is made to fit the first cross section at the first scale given. If the cross section fits on the sheet, it is drawn and, provided paging is invoked, an attempt is made to fit the next section on the next sheet. If it does not fit, then the next scale is attempted and so on.

**Input**

**Linemode**

**Cross section drawing (automatic setting)**

First record:

**Minor option 803**

- Field 1      ACRS to invoke automatic setting of drawing scale
- Field 2      PAGE to invoke automatic paging.  
NOPA to produce one page only.
- Field 3      NOTR to restrict truncation.
- Field 4      Positive value - displacement from highest string point to top of section window in model units.  
Negative value - maximum level displayed in the section window in model units.

1. Specification of origin in absolute model units.
  - Field 8      Origin of vertical axis in model units. (Absolute level datum).
2. Specification of origin in displacement model units.

Field 9 Positive value - displacement from lowest string point to the horizontal axis. The resultant datum level is rounded down. Negative value - the nearest multiple of the given value below the lowest string point.

Subsequent records:

**Minor option 803**

- \* Field 7 Horizontal scale.
- \* Field 10 Vertical scale.
- ◇ *Up to ten records may be used to specify the drawing scales.*
- ◇ *The drawing scales must be coded in ascending order.*

**Example**

```

DRAW, SECTIONS MODEL
800, 4=1.0, 5=3
803, ACRS, PAGE, NOTR
803, 7=50, 10=50
803, 7=100, 10=100
803, 7=200, 10=200
.
.
.
999
    
```

**Define a boundary**

This option is only available in graphics. The facilities provided are complementary to those available in minor option 804.

**IGDRAWT.DAT, DRW004, DRW039**

DRAW - Option details	Define a boundary
Model for DRAW	IN/OUT (T)
Draw all strings	Boundary string label
Draw all strings (DETA)	Minimum X
Draw selected strings	Y
Draw raster backcloth	Maximum X
Draw using a macro	Y
Define a boundary	Length (mu)
Add drawing details	Width (mu)
Create new sheet	
End DRAW	

## Minor option 804 Define part of model

Define the part of the model to be drawn.

This option must be used for section drawings but may be omitted for plan drawings.

Often a model will contain a considerable amount of information that is not required on a drawing and minor option 804 provides a variety of ways to select the model information to be drawn.

### Plan drawing

The required part of the model can be defined in relation to a closed boundary string, either the part inside or outside the boundary. A simpler method defines a rectangular area of interest by maximum and minimum coordinates. A further alternative is to combine both methods.

If a drawing window has been defined that is smaller than the part of the model defined the model information lying outside the window will be clipped (not drawn) unless automatic paging has been requested.

### Input

#### Linemode

#### Plan drawing

##### Minor option 804

Field 1 PLAN

Field 2 IN = draw information inside boundary string  
OUT = draw information outside boundary string.

Field 3 Boundary string label.

If the string resides in a different model from the strings drawn, the model name should be coded on the DRAW major option.

And/Or

Field 5 Minimum X) coordinates of

Field 6 Minimum Y) rectangular

Field 8 Maximum X) boundary

Field 9 Maximum Y)

◇ *If this option is omitted the whole model will be considered for drawing*



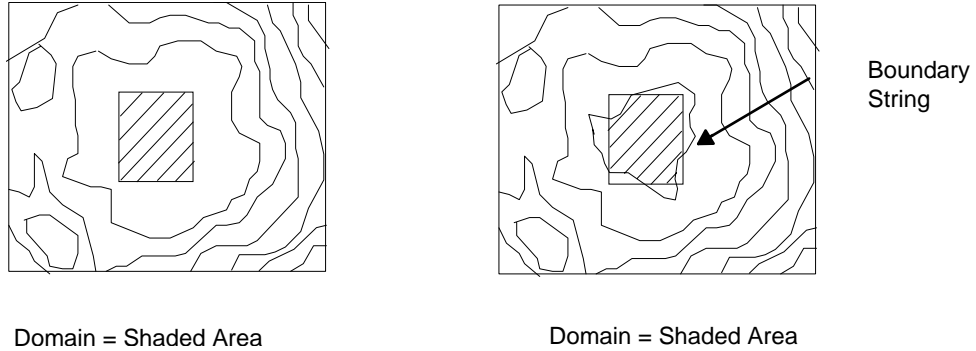


Figure 3 - 101 Example - define part of model

Example

804 , PLAN , IN , BDRY , 5=1234 , 2345 , , 3456 , 4567

Long section drawing

Continuous long sections

The required area is either defined in terms of a start and end distance, if the long section has been derived from a reference string, or in terms of the coordinates used to define the baseline. If the domain so defined is larger than the drawing window the information outside the window will be clipped. Where automatic paging is invoked the amount drawn in each window will be determined by the window size unless a length of section is specified in which case each window will contain only that length.

◇ *The maximum level is taken from the strings to be plotted.*

Input

Linemode

Long section drawing (continuous sections)

Minor option 804

- \* Field 1      LONG
- Field 4      Length of section to be drawn on each page, if omitted the length to be drawn will be determined by the length of the drawing window.

A number of alternatives is provided.

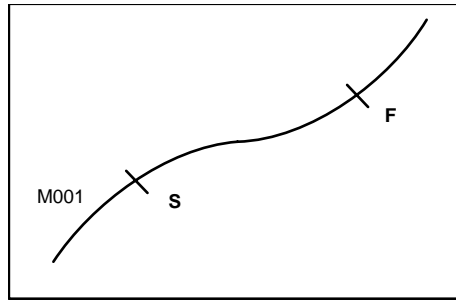
1. Define the distance axis relative to a string.

- \* Field 3      Reference string.
- Field 5 & 6    SPRD for start.
- Field 8 & 9    SPRD for end.

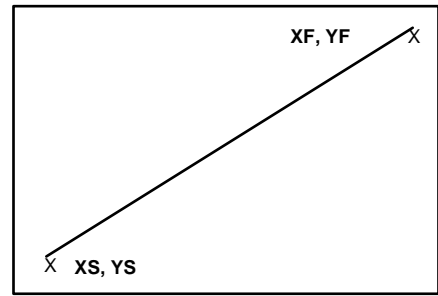
2. Define the distance axis relative to a base line.

- Field 5 & 6    Model coordinates for start.

Field 8 & 9 Model coordinates for end.



domain = M001 (S-F)



domain = (XS, YS) - (XF, YF)

**Figure 3 - 102 Example - 804 Longsection**

Examples

Restrict the draw limits relative to a string:

804, LONG, , MREF, 5=100, 8=900

Restrict the draw limits to be between two coordinates:

804, LONG, 5=100, 100, , 300, 300

## Stepped long sections

Stepped long sections allow strings to be drawn which might otherwise disappear out of the drawing window at the upper or lower boundary. A common datum can be set up for each stepped section using minor options 845, 847 and 848.

If the datum level is to be repeated for each stepped section, the box name must be DT and the variable name must be DV.

## Input

### Linemode

#### Long section drawing (stepped sections)

##### Minor option 804

Field 1        STEP

Field 2        WIND to create a step at the first string intersection with the drawing window (default).

POIN to create a step at the first string point before the intersection with the drawing window.

CHAN to create a step at the nearest whole number to a specified chainage factor (or multiple thereof) which occurs before the intersection with the drawing window. The chainage factor is specified in Field 10.

Field 3        Reference string.

Field 4        Length of section to be drawn on each page.

Field 5 & 6    SPRD for start.

Field 8 & 9    SPRD for end.

Field 10       Chainage factor. Only used if Field 2 is set to CHAN.

◇ *If no length is coded, a suitable scale must be chosen to ensure that all the strings appear on the sheet.*

◇ *NOTR must be coded in the preceding 803 option to maintain the window size.*

### Example

The following example draws a stepped long section on an A0 sheet. The margins are all 5cm except for the top margin which is 50cm (this leaves room at the top of the sheet for another drawing). The scale is 1:100 horizontally and 1:10 vertically.

The stepped long section has steps occurring at the nearest string point before the intersection with the drawing window. Each sheet contains 100m of section.

```

DRAW, LONGSECTIONS MODEL
800, 4=1, 5=0
802, 5=5, 5, , 5, 50
803, LONG, , NOTR, 7=100, 10=10
804, STEP, POIN, MAST, 100
826, MAST
826, LSEC
.
845, LBLB, CC, DT, 6=-6, 6, 9=0, 1.0
848, MAST, , DV, 7=-9
847, *, , DT, 10=0.0
001, Datum = &DV&m.
.
999

```

- ◇ *The use of paging with stepped long sections is not currently available.*
- ◇ *If PAGE is specified in Field 2 of the minor option with 804 STEP, it will not work.*

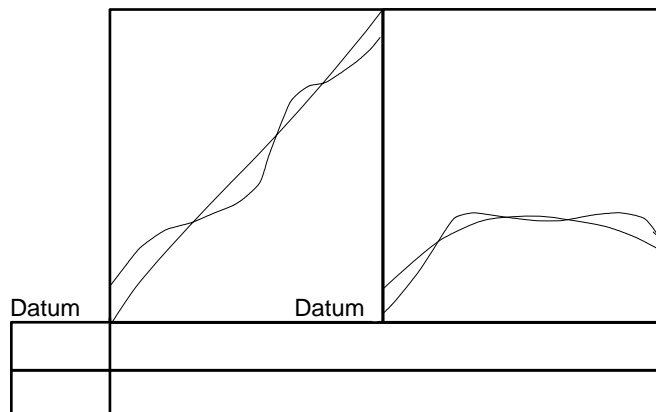
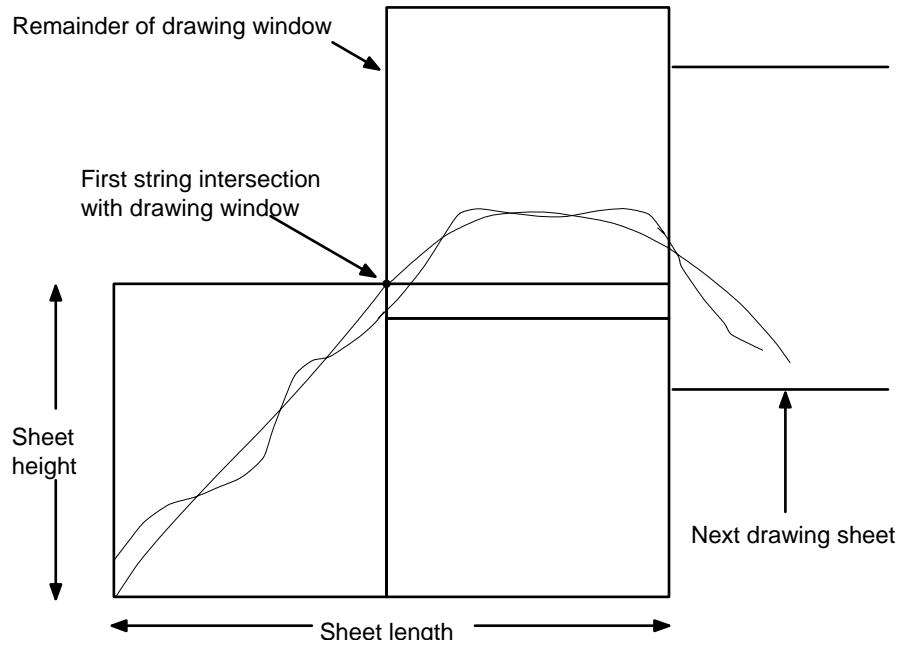


Figure 3 - 103 Stepped long section

## Cross section drawing

The required sections can be selected by giving a start and end section plus a distance interval which would need to be a multiple of the original distance interval used to extract the sections. For example, draw sections at 100 metre intervals where the full set is at 10 metre intervals. Alternatively a section spacing interval can be given to select every second, third, or fourth section.

The maximum extent of the horizontal (offset) axis can either be defined as absolute minimum and maximum offsets or as incremental offsets to be added to the largest offsets encountered among all of the sections to be drawn.

Note that the maximum level is taken from the strings to be plotted.

### Input

#### Linemode

#### **Cross section drawing**

##### Minor option 804

Field 1        CROS

Field 4        Distance interval, this determines which sections will be drawn, it must be a multiple of the original section interval. If a negative value -n is coded, every n'th section will be drawn.  
A reference chainage for distance intervals may be specified on an additional 804 record.

A number of alternatives is provided. Two alternatives for specifying the sections to be drawn are provided:

1. Specification of reference string from which sections were generated.

Field 3        Label of reference string used to generate the sections.

Field 5 & 6    SPRD for first section to be considered.

Field 8 & 9    SPRD for last section to be considered.

2. Specification of base line from which sections were generated.

Field 5        X coordinate of start point

Field 6        Y coordinate of start point

Field 8        X coordinate of end point

Field 9        Y coordinate of end point

Two alternatives for specifying the extent of the horizontal axis are also provided. Note that either of these can be specified simultaneously with one of the previous alternatives.

1. Specification of horizontal extent using absolute offsets (model units).

Field 2        ABS

Field 7        Left offset (negative) measured from the reference string.

Field 10       Right offset (positive) measured from the reference string.

2. Specification of horizontal extent relative to the edge of each section (model units).

Field 2        ADD

Field 7        Incremental offset (negative) to be added to the left of each section.

Field 10       Incremental offset (positive) to be added to the right of each section.

Field 3        Label of reference string used to generate the sections.

Field 5 & 6    SPRD for first section to be considered.

Field 8 & 9    SPRD for last section to be considered.

2. Specification of base line from which sections were generated.

Field 5        Easting of start point

Field 6        Northing of start point

Field 8        Easting of end point

Field 9        Northing of end point

3. Specification of internal margins in absolute model units.

Field 2        ABS

Field 7        Minimum offset, convention is negative to the left, positive to the right in the direction start point to end point (ABSL).

Field 10       Maximum offset, convention is negative to the left, positive to the right in the direction start point to end point (ABSR).

4. Specification of internal margins in displacement model units.

Field 2        ADD

Field 7        Absolute value of the increment of offset to be added to the left to each section in the first set of sections to define the maximum left offset to be plotted for the first and all subsequent superimposed sets of section (ADDL).

Field 10       Absolute value of the increment of offset to be added to the right of each section in the first set of sections to define the maximum right offset to be plotted for the first and all subsequent superimposed sets of sections. The standard offset convention is used (ADDR).

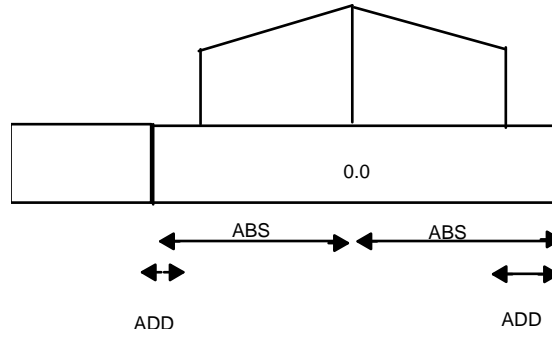


Figure 3 - 104 Example - 804 cross section

Example

804 , CROS , 2=ADD , 3=MREF , 4=100 , 5=100 , 8=900 , 2=ADD , 10=+10



**Additional information for long and cross section drawing**

A reference chainage may be specified from which distance intervals are to be measured.

For long sections this applies to both the distance interval for annotation specified in option 846 field 4 and that for the drawing of ordinates which is specified in option 849 field 4.

For cross sections it applies to the distance interval specified in option 804 field 4 which determines which section will be drawn.

In each case the rules of application are the same:

- 1 Sections/Annotation will always be drawn at the start and end chainages.
- 2 Sections/Annotation will be drawn at a chainage if that chainage minus the reference chainage is a multiple of the distance interval.

**For example**

If the chainages stored are

10, 20, 30, 40, 50, 60, 70, 80, 90, 100, 110

Then with the following specifications

Start chainage : 10

End chainage : 100

Distance Interval : 20

Reference chainage : 0 (Default)

Sections/annotations will be drawn at the following chainages

10, 20, 40, 60, 80, 100

If the start and end chainages and the distance interval were the same, but the reference chainage was 10 then Sections/Annotation would be drawn at the following chainages.

10, 30, 50, 70, 90, 100

If used this option must immediately follow either an 804, LONG or an 804, CROS option.

**Input**

**Linemode**

**Reference chainage**

**Minor option 804**

Field 1 NEXT

Field 4 Reference chainage

**Example**

804 , CROS , 4=20

804 , NEXT , 4=10

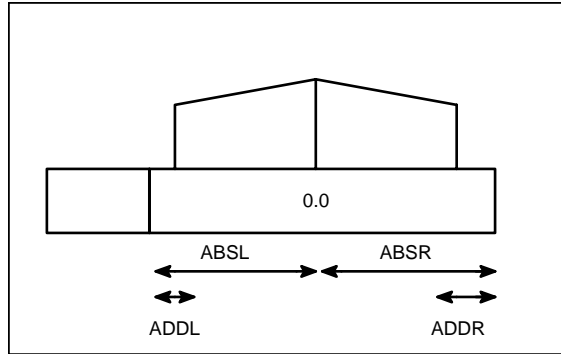


Figure 3 - 105 Example - Cross section layout

## Minor option 805 Line type and colour

Sets the current pen for drawing lines.

If omitted the installation default values will be used.

If minor option 805 is given with no other data the pen type and colour for lines are set or reset to the installation defaults.

When identifying null or zero levels with minor option 825, a second line colour is required. Field 7 of this minor option is used to indicate that this second colour is being defined.

### Input

### Graphics

The definition of line colours in IGMODE is explained in Chapter 2 'Throughout MOSS'.

### Linemode

#### Minor option 805

Field 1,2 Ink colour.

The colours available for this option are defined in the file 'drcolour.dat'.

Field 3 Pen type.

Field 4 Pen size (liquid ink pens only).

Field 7 Null/zero levels indicator

Blank Pen to be used for all lines (default)

1 Pen to be used to indicate null/zero levels

◇ *Field 7 is valid only if minor option 825 field 2 is coded NCOL, ZCOL, NULL or ZERO.*

### Example

805, YELL, , BIRO, 4=0.1

## Minor option 806 Text type and colour

Set current pen type for drawing text.

If omitted the installation default values will be used.

If minor option 806 is given with no other data the pen type and colour for text are reset to the installation defaults.

### Input

#### Graphics

The definition of text colours (and other attributes) in IGmode is explained in Chapter 2 'Throughout MOSS'.

#### Linemode

##### Minor option 806

Field 1,2 Ink colour.

The colours available for this option are defined in the file 'drcolour.dat'.

Field 3 Pen type.

Field 4 Pen size (liquid ink pens only).

### Example

```
806, BLAC, , INK, 0.2
```

## Minor option 807 Fill area characteristics

Sets the fill area characteristics for use by all hatching and fill area options. Hatching styles which can be created include standard hatching, cross hatching and double pitch hatching. Areas can also be filled using standard symbols or macrosymbols.

If minor option 807 is specified with no field data, the colour, hatching intervals and angles are set to the defaults specified in the parameter file.

If no macrosymbol name or standard symbol number is specified, hatching is used as the fill area style.

### Input

#### Graphics

To set or modify fill area characteristics select 'Fill' in the static menu area. This is described in Chapter 2 'Throughout MOSS'.

IMMENUT.DAT GRFFSA

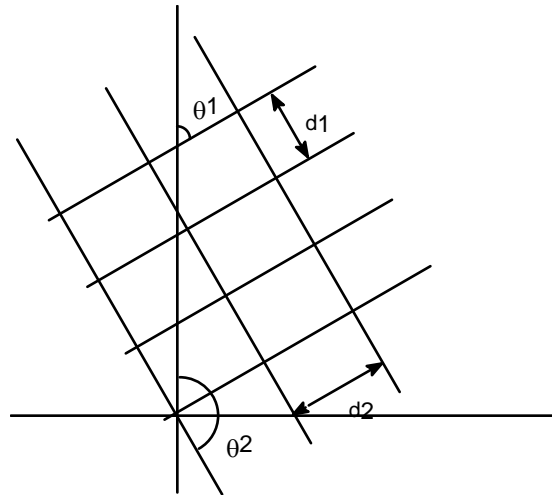
Interval/Spacing 1
Angle 1
Interval/Spacing 2
Angle 2
Macrosymbol name
Standard symbol number
Symbol width
Symbol height

Linemode

Minor option 807

- Field 1      Colour of fill pattern.  
The colours available for this option are defined in the file 'drcolour.dat'.
- Fields 2&3    Macrosymbol name
- Field 4      Standard symbol number  
  - ◇ *If Fields 2, 3 and 4 are blank, hatching is used as the fill area style.*
- Field 5      Width of standard symbol or macrosymbol
- Field 6      Secondary hatching interval OR  
Secondary spacing interval (default same as primary interval).  
If the hatching interval is set to 0.001, solid fill is used.
- Field 7      Primary hatching interval OR  
Primary spacing interval (default held in parameter file)  
If the spacing interval is set to 0.0, the symbols are positioned randomly.
- Field 8      Height of macrosymbol.
- Field 9      Secondary angle of fill (default primary angle of fill plus 90 degrees).
- Field 10     Primary angle of fill (default held in parameter file).  
  - ◇ *A list of the standard symbols can be found under minor option 863 'Standard symbol points'.*
  - ◇ *If field 7 is set to zero, and field 9 and 10 are identical; symbols will be drawn with a random rotation.*

- ◇ *If field 7 is set to zero, and field 9 is undefined; symbols will be drawn using the primary angle of fill defined in field 10.*



**Figure 3 - 106** Fill area hatching

**Example 1**

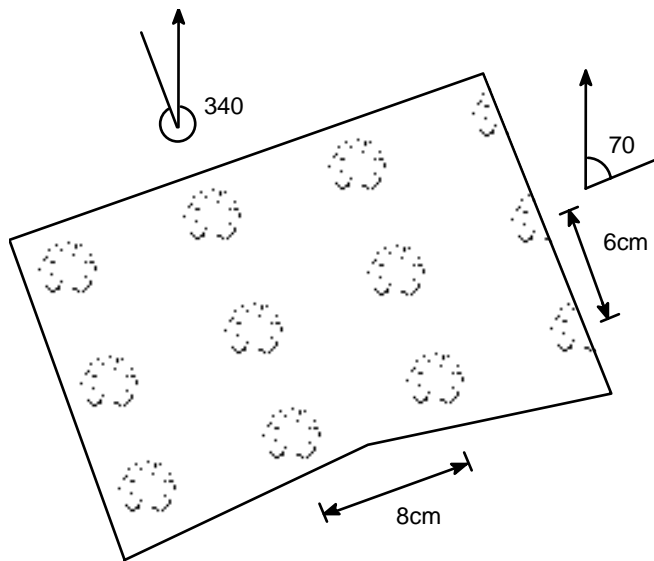
This example sets the fill area to yellow single hatching at an interval of 0.1 and at an angle of 45 degrees.

807, YELL, 7=0.1, 10=45.0

**Example 2**

This example draws the TREESYMB macrosymbol at a size of 1.5 x 1.5. The spacing intervals are set to 6cm and 8cm with the symbols drawn at angles of 70 and 340 degrees respectively.

807, GREE, TREESYMB, 5=1.5, 8, 6, 1.5, 340, 70  
879, BDRY, 7=1

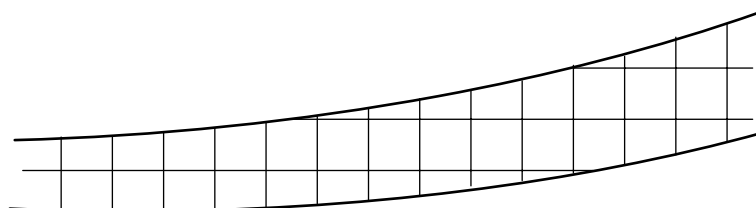


**Figure 3 - 107 Fill area with macrosymbol**

**Example 3**

This example draws cross hatching by defining just the secondary interval. Defaults are assumed for the primary interval, the primary angle and the secondary angle.

807, 6=0.25  
875, CLEF  
876, CRIG



**Figure 3 - 108 Fill area with cross hatching**

## Minor option 808    Set current text style

If omitted the installation defaults will be used. These values will be used by any of the drawing options that use characters. The list of facilities below represents the maximum possible range and some of these facilities may not exist on every system. A check should be made to see what is available on any particular installation.

The option provides for the selection of:-

- Font - Plotter dependent
- Software fonts (See Guide to MOSS Software fonts)
- Upper/Lower case combinations
- Character Height and Height/Width ratio
- Character spacing and line spacing interval
- Line thickness
- Number of decimal places
- Prefix or suffix, eg +, £, \$, %
- Separator character for thousands and the decimal point.

Because of the potential complexity of these specifications it is possible to give a set of data a name called the "style" which is a shorthand way of recalling the combination at any time during the MOSS run in which it is created.

If minor option 808 is given with no other data the values will be reset to the installation defaults.

The character width, character spacing and line spacings are defined as proportions of the character height and are the distances between the character tiles.

### **Character width**

character height x character width ratio = character width

eg.  $0.18 \times 0.5 = 0.09$  drawing units

### **Character spacing**

character height x character spacing ratio = character spacing

eg.  $0.18 \times 0.5 = 0.09$  drawing units

### **Line spacing**

character height x line spacing ratio = vertical character spacing

eg.  $0.18 \times 0.5 = 0.09$  drawing units.

- ◇ *Many plotters only operate with character width and character spacing ratios of 1.0. If different values to 1.0. are used any drawing on the graphics terminal may not be identically reproduced by a plotter, unless software fonts are used (See Guide to MOSS Software fonts).*
- ◇ *The default values for character width and spacing ratios are held on the parameter file.*
- ◇ *The default value for the line spacing ratio is held on the parameter file.*

Input

Graphics

To select or add a font select 'text' in the Static Menu area.

IMMENUT.DAT GRFEE, GRFCSA

TEXT	
1 :Height = 0.180	Text style name
2 NEW	Font name
	Character height
	Width to height ratio
	Character spacing ratio
	Line spacing ratio
	Case code (T)
	Prefix or suffix
	Thousands separator
	Decimal part separator

- ◇ *The text menu will list all available character styles and software fonts by their style name.*
- ◇ *The text style name is limited to 4 characters.*
- ◇ *The font name is limited to 4 characters. In the case of a software font it must be in the form sofX where X is an alphanumeric in the range 1 to 9, a to z. In the case of a hardware font it must be in the form fonX where X is an alphanumeric in the range 1 to 9, a to z. The number of hardware fonts available is dependent upon the type of plotter being used.*

Linemode

Minor option 808

Field 1 Font name

Field 2 Column 1

- L All alphabetic characters to be drawn in lower case with a prefix.
- O All alphabetic characters to be drawn in lower case with a suffix.
- U All alphabetic characters drawn in upper case with a prefix.
- P All alphabetic characters drawn in upper case with a suffix.



- N No conversion - all characters drawn as input with a prefix.
- S No conversion - all characters drawn as input with a suffix.

Column 2

Code the character that will prefix or suffix all numbers, eg + or £ or \$ or %. If not required, leave blank.

Column 3

Separator character for thousands

+ gives 5 + 678.0

0 gives no separator 5678.0

1 gives 5 678.0

2 gives 5,678.0

3 gives 56+78.0

4 gives 5+678.0

If special action not required, leave blank.

Column 4

Separator for the decimal part

0 gives no separator 5678 (only use with no decimal places)

1 gives 5678 0

2 gives 5678,0

for a decimal point, leave blank.

- Field 3 Code a four character text style name if you want MOSS to remember the combination of data on this option for later recall within the current entry to DRAW, otherwise leave blank.
- Field 4 Character height in current linear measure units.
- Field 5 Number of decimal places to be used on numeric values.
- Field 6 Width to height ratio of characters expressed as a decimal fraction eg, 1.5 gives wide characters.
- Field 7 Character spacing ratio. This is the distance between one character and its neighbour.
- Field 10 Line spacing ratio. This is used in conjunction with the text increment options which are described under the special annotation options.

To recall a previously defined text 'style' code the following:

Minor option 808

Field 3 Style name

Example

808 , 2=N\$2 , 3=PUND , 5=2

would produce text as follows:

'The Cost Of Machine Time Is \$1,234.56 Per Day'

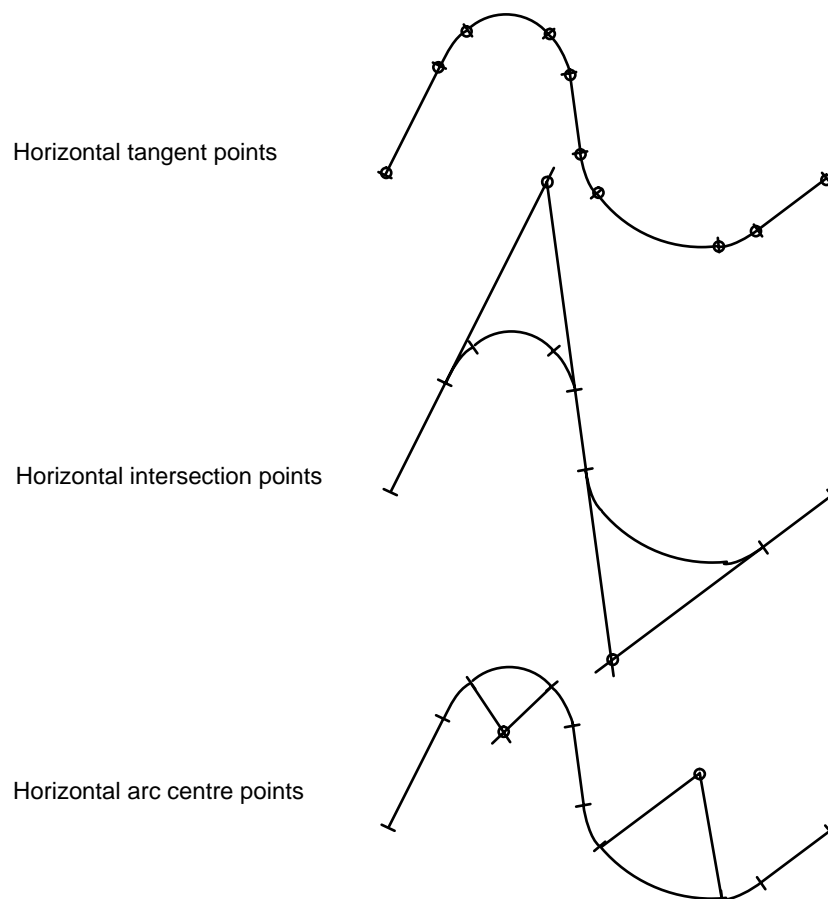
## Minor option 809 Geometry string annotation

Sets the geometry string code and text annotation offsets for use by subsequent DRAW annotation options.

### Geometry string code

Geometry strings store information about an alignment, for example, the horizontal and vertical tangent points of a string. Once you have set the geometry string code, any subsequent annotation options you specify which use geometry strings will extract the corresponding information from the geometry string.

Refer to Figure 3 - 109 and Figure 3 - 110 for a pictorial representation of geometry string codes.



**Figure 3 - 109 Horizontal geometry string points**

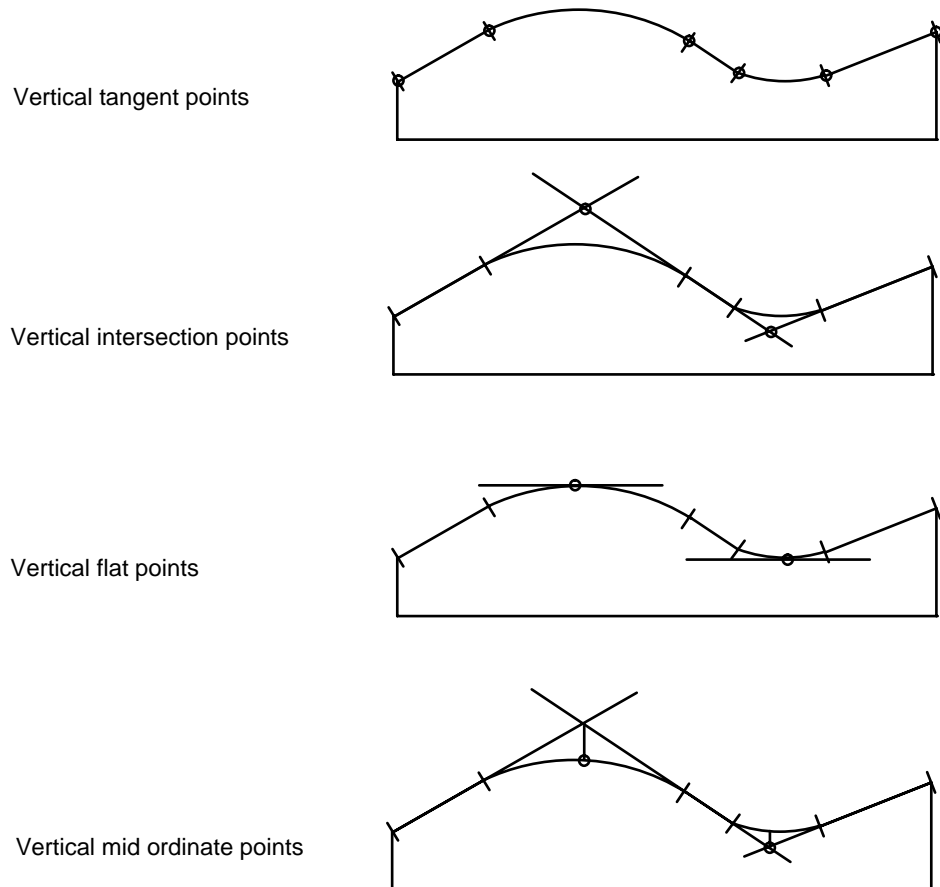


Figure 3 - 110 Vertical geometry string points

### Annotation offset

This option may also be used to specify the primary and secondary text annotation offsets. Subsequent DRAW annotation options use these offsets to determine the position of text in plan and on long sections. Text may be drawn on one side of the string only or on the inside or outside of curves.

If minor option 809 is specified with no field data, the geometry string code and annotation offsets are set to the defaults specified in the parameter file.

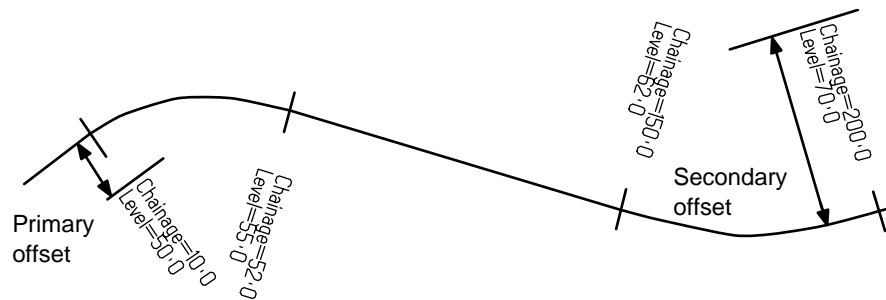


Figure 3 - 111 Primary and secondary annotation offset

Input

Graphics

IGDRAWT.DAT, DRW018,DRW057

Annotation	Geometry string annotation
Geometry string annotation	Geometry string code
Information along a string	Offset convention (T)
Information at points	Annotation offset
Pips	Secondary offset
Macrosymbols at string pts	Crossfall units (T)
Scaled macrosymbols at pts	Cant units (T)
Standard symbols at a pt	Chainage base
Between string points	
Point sequence numbers	
Chainages on 1 side only	

◇ On selection of 'Geometry string code', a further menu is displayed showing a list of geometry string codes.

Linemode

Minor option 809

- Field 1      Geometry string code
- HTPS      Horizontal tangent points
  - HCEN      Horizontal arc centres
  - HIPS      Horizontal intersection points
  - VTPS      Vertical tangent points
  - VIPS      Vertical intersection points
  - VFPS      Vertical flat points
  - VMOS      Vertical mid-ordinate points
  - SUPE      Superelevation points
- The default geometry string code is determined by the variable DGSTGCOD in the parameter file.
- Field 2      Offset indicator.
- ONES      Annotation is to be drawn on one side of a string.
  - INOU      Annotation is to be drawn on the outside or inside of curves in a string.
- Field 4      Superelevation indicator (2 digits, only used if Field 1 = SUPE)
- For crossfall annotation (first digit):
- 1            Annotate crossfall as a percentage.

- 2 Annotate crossfall as a decimal percentage.
- 3 Output crossfall as a ratio (1:n)
- For cant annotation (second digit):
  - 1 Annotate cant in metres (or feet)
  - 2 Annotate cant in centimetres (or inches)
  - 3 Output cant in millimetres
- ◇ *Crossfall is annotated if a code of XF\*\* is found on the geometry string. Cant is annotated if a code of CA\*\* is found on the geometry string.*
- ◇ *Metric or imperial units are used for cant depending upon the units set in the parameter file.*
- Field 7 Primary annotation offset.  
 The primary offset defines the position of text on either side of a string.  
 If Field 2 = ONES, in plan, a positive offset is to the right and a negative offset to the left. For long sections, a positive offset is above the string and a negative offset below. Text is always drawn left justified.  
 If Field 2 = INOU, in plan and for long sections, a positive offset is to the outside of curves and a negative offset to the inside.  
 The default primary offset is determined by the variable DSTRAOFF in the parameter file.
- Field 8 Secondary annotation offset (only used if Field 2 = INOU).  
 The secondary offset defines the position of text on the left hand side of a string, so that text may be left justified.  
 If a secondary offset is not specified, the primary offset is used and text on the left hand side of a string is right justified.
- Field 9 Chainage base  
 Enter chainage base for incremental style chainage annotation.
  - ◇ *Fields 7 and 8 define text annotation offset only, and not symbol offset.*
  - ◇ *The primary annotation offset may be overridden by specifying an offset on the individual minor option.*

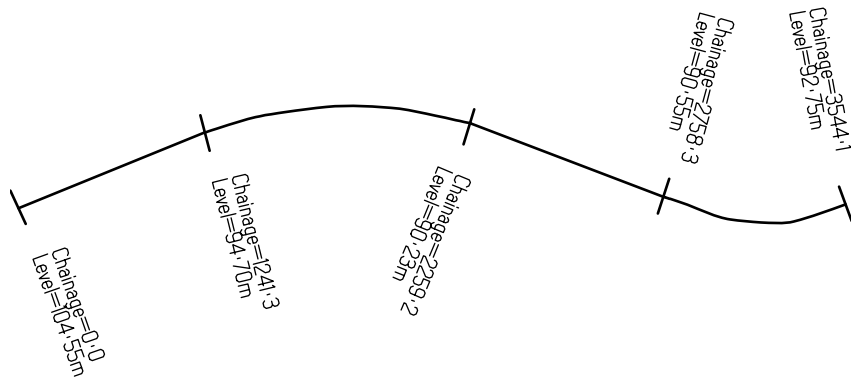
### Example 1

This example draws an M string and annotates the horizontal tangent points with the chainage and level extracted from the associated geometry string.

```

DRAW, SIMPLE DESIGN ROAD
803, 7=500
825, MAST
809, HTPS, INOU, 7=-0.25, -2.0
859, GAST
859, 3=CHAI, 4
  
```

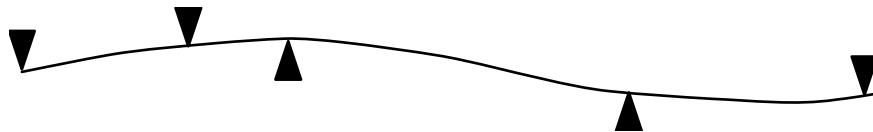
```
001,Chainage=&CHAI&
859,GAST,D001
859,3=LEVL,3
001,Level=&LEVL&m
999
```



**Figure 3 - 112 Master string annotated with chainage and level**

This example draws an M string in a long section and annotates the geometry string with arrow symbols at the vertical tangent points. The symbol ARROSYMB is drawn at each point and minor option 861 defines the angle and size of the symbol.

```
DRAW,HAVERING SECTIONS
803, LONG, 7=500, 10=100
804, LONG, , LSEC
826, M001
809, VTPS, INOU
861, G001, ARROSYMB, 0.5, 10=90
999
```

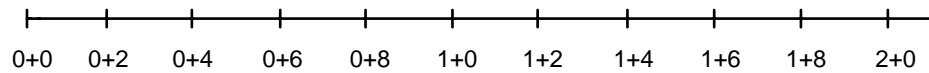


**Figure 3 - 113 Master string annotated with arrow symbol**

### Example 2

This example draws an M string with incremental style chainage annotation.

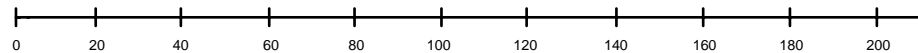
```
DRAW, MODELNAME
809, 9=100
825, MAST
867, MAST, 10=20
```



**Figure 3 - 114 Master string annotated in increments**

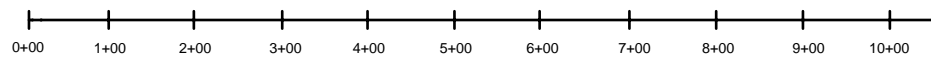
The data above requests chainages in increments of 100m but at 20m intervals, i.e. the first increment of 100m is annotated 1+00.

The true chainage of the above example is:



### Example 3

If chainage is set in increments of 20m at 20m intervals it will appear as follows:



So chainage 10+00  
 = (10 x increment)  
 = (10 x 20)  
 = 200

## Minor option 810 Set current line style

There are three types of line styles; solid lines, four element dashed lines and macrolines.

Dashed lines are produced by repetitive drawing of a basic four element pattern. The four elements are a solid line, a space, another solid line which can be rotated and a second space. The lengths of each element are user definable.

Macrolines are produced by repeated drawing of a basic pattern. The basic pattern may be stretched between points and the depth of the pattern adjusted accordingly. Alternatively the depth of the pattern may be derived from information stored within a string. Macrolines must be predefined and stored in the macrofile using major option MACRO.

The defined line style is used in all subsequent options except those where specific reference is made to a particular line style. This option may be used repeatedly to change line styles.

◇ *If minor option 810 is given with no other data the linestyle will be set to the installation default.*

- ◇ *Macrolines should not be confused with macrosymbols and standard symbols: macrolines are drawn between two or more points, whereas macrosymbols and standard symbols are located at individual points.*

**Input**

**Graphic**

To select or add a line style select 'line' in the static menu area. You will see the following display.

GRFAA, GRFLSA

LINE	
1	Length of first line
2 NEW	Length of first gap
	Angle of second line
	Length of second solid line
	Length of second gap

The second menu will appear only if NEW is chosen, allowing you to define and name the new line style.

- ◇ *The line menu will display all available line styles and macrolines.*
- ◇ *To generate and store macrolines see Chapter 13.*

**Linemode**

**Define a four element dashed line**

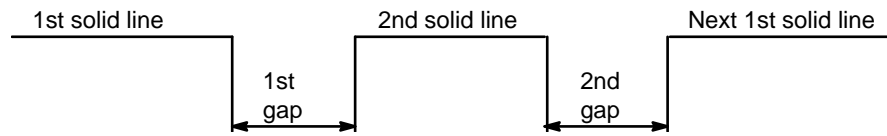
Minor option 810

- Field 1      DASH
- \* Field 5      Length of first solid line in current linear measure units.
- \* Field 6      Length of first gap.
- Field 7      Clockwise rotation of second solid line relative to first solid line.
- \* Field 8      Length of second solid line.
- \* Field 9      Length of second gap.

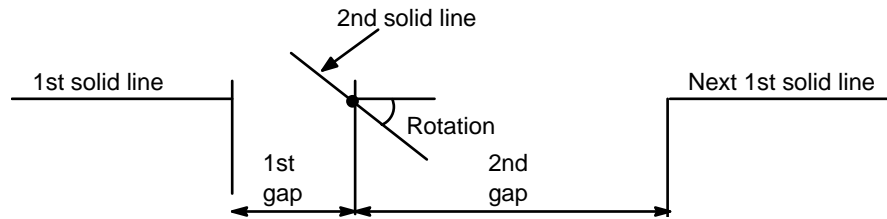
- ◇ *The length of the first gap is -*
  - a) *measured between the ends of the 1st and 2nd solid lines when the rotation of the 2nd line is 0<sup>0</sup>.*
  - b) *measured between the end of the 1st solid line and the centrepont of the 2nd line when its rotation is not 0<sup>0</sup>.*



- ◇ *The length of the second gap is measured in the same way as the first gap but between the 2nd solid line and the next 1st solid line.*



**Figure 3 - 115 Four element dashed line, rotation = 0°**



**Figure 3 - 116 Four element dashed line, rotation ≠ 0°**

**Define a macroline**

Minor option 810

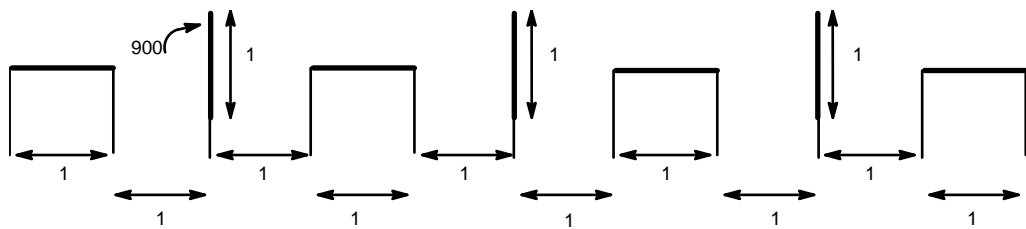
- Field 1      MACR
- \* Field 2, 3    Name of the macroline. The macroline should have been previously defined and be stored in the macrofile.
- Field 4      The string dimension to be used to determine the depth of the macroline. The value stored in the string is assumed to be model units. The depth defined at a point extends to the following point.  
If this field is coded then field 6 should be left blank.
- Field 5      Drawn length of the pattern in current linear measure units.  
If -1.0 is coded the pattern will be stretched between adjacent string points.  
If -n is coded the pattern will be stretched between points 1 and 2 and between points n+1 and n+2 and between points 2n+1 and 2n+2 and so on.  
An example of this would be with a string containing the location of gates, in which case n=-2.0 would produce a 'gate-line' between every pair of consecutive points.
- Field 6      Depth of the pattern.  
If the depth is positive drawing units (ie cms or inches) are used.  
If the depth is negative model units are used.  
If this field is coded then field 4 should be left blank.  
If neither field 4 nor field 6 is coded then the pattern will be drawn with its original length/depth ratio.

If a macroline has been defined with reference points these will be used to scale the pattern provided field 5 is negative. In this case the reference points in the macro will coincide with the string points.

Field 7 The scale to be used for converting the depth of the macroline from model units to drawing units.

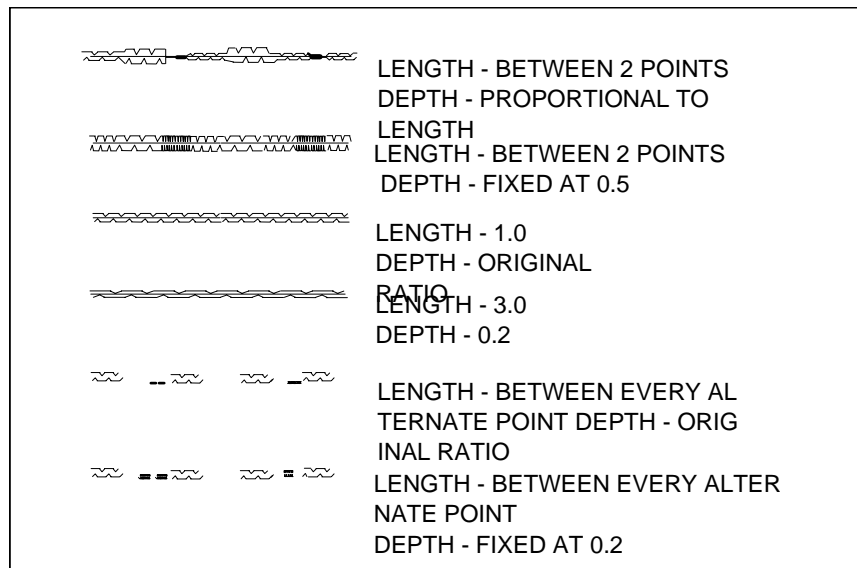
**Examples**

1. 810,DASH,5=1.0,1.0,90.0,1.0,1.0



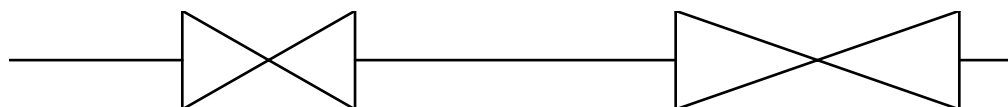
**Figure 3 - 117 Example - dashed line**

2. 810,MACR,HEDGE,,-1.0



**Figure 3 - 118 Example - macrolines**

3. 810,MACR,GATE,5=-2.0



**Figure 3 - 119 Example - gate macro**

## Minor option 812 Set curve fitting

If omitted curve fitting will not be applied.

There are two styles of curve fitting available, MOSS and SPLINE. The approach adopted by MOSS is to derive the appropriate curve and insert sufficient additional points between points on the string to ensure that the chord to arc distance is smaller than a tolerance. These additional points are generated so that linear plotting can be carried out. Curve fitting is more fully described in Chapter 2.

Option 812 stays in force for subsequent drawings unless changed by another 812 option.

### Input

#### Graphic

To change the curve fitting setting select 'Curve' in the Static Menu Area.

#### Linemode

#### Minor option 812

Field 1	Curve fit indicator
	OFF No curve fitting required.
	MOSS Use curve fitting.
	SPLI Spline type fitting.
* Field 4	Chord to arc tolerance

## Minor option 814/815 Create an object

Objects are collections of strings, annotation, enhancement etc which can be grouped together. An object is initialised by assigning a name to it via minor option 814. All subsequent minor option commands are linked to the object until it is closed by option 815.

At any one time only one object may be open. Elements may be transferred from an object into the current object, and elements may be deleted from objects.

Optionally, when an object is opened, elements which become part of the object can be grouped together and formed in to a new, single element for drawing purposes. All elements added to the object become part of the new element until the object is closed, at which time the new element is complete. Single element objects may be used to draw large models as backcloths, as it is qucker to draw a single large element than many small ones.

◇ *Objects are inhibited in section drawing.*

- ◇ *Individual lines, points or text in single element objects cannot be selected. To erase single element objects or make them invisible, type the object name.*

## Input

### GENOB

- ◇ *There is no facility to create a single element object in IGMODE.*

## Linemode

### Minor option 814

Field 1        'SING' - object is formed as a single element

- \* Field 3        Name of object to be opened.

### Minor option 815

No associated data.

## Example

Create an object OBJ1 with two elements:

```
814 , 3=OBJ1
805 , RED
826 , STR1
805 , GREEN
826 , STR2
815
```

Create two objects SH01 and SH02, each containing a single element:

```
DRAW , OSSHEET1
803 , 7=1250
814 , SING , , SH01
825
999
DRAW , OSSHEET2
801 , OVER
814 , SING , , SH02
825
999
```

## Minor option 817 Erase element

Erases all occurrences of an element, all occurrences of an element within an object, or a complete object.

## Input

### Linemode

#### Minor option 817

- Field 1      Element to be erased from the object specified in Field 3.  
                 If this field is blank, the object specified in Field 3 is erased.
- Field 3      Name of object containing element(s) to be erased.  
                 If this field is blank, all occurrences of the element specified in  
                 Field 1 are erased.

### Example

Erase string L001 from object TREE:

```
817,L001,3=TREE
```

Erase all occurrences of string L001:

```
817,L001
```

Erase the object TREE:

```
817,3=TREE
```

## Minor option 818    Set clip status

This option permits any drawing element to be designated permanent or erasable.

Permanent and erasable elements are handled in different ways by the clipping analysis used by major option CLIP.

Permanent elements are not changed by clip polygons which intersect them.

Erasable elements are subject to clipping analysis and are:

- clipped if any part of the element intersects with any clip polygon
- deleted if the element is totally surrounded by any clip polygon.

Elements are designated as clip polygons using minor option 819, 'Set clip parameters'.

For more information about clipping, refer to major option CLIP.

## Input

### Graphics

This option is accessed from the Envir button in the static menu area. See Chapter 2 for further details.

Linemode

Minor option 818

Field 1	Clip status
	PERM Permanent element
	ERAS Erasable element (default)

## Minor option 819 Set clip parameters

This option allows you to create clip polygons to be used during clipping analysis by major option CLIP.

A clip polygon erases any part of an erasable element which lies within its boundary. Elements are set as erasable or permanent using minor option 818, 'Set clip status'.

All elements can be used to create clip polygons except those listed below:

- Strings drawn with minor options 825 and 826 unless they are drawn as solid lines without detailed interpretation.
- Meshes created with minor option 881.
- Triangulations.
- Hatching drawn between two lines or two strings created with DRAW minor options 875, 877 and ENHANCE minor options 895 and 897.
- Permeable lines in macrosymbols.

In addition, frames and windows created using minor option 821 clip information lying outside their boundary so that drawing sheet margins may be cleared.

For more information about clipping, refer to major option CLIP.

### Input

### Graphics

This option is accessed from the Envir button in the static menu area. See Chapter 2 for further details.

Linemode

Minor option 819

Field 1	POLY or NOPO
	POLY Set subsequently drawn elements to be clip polygons
	NOPO Set subsequently drawn elements to normal (default)
Field 2	BOX or NOBX
	BOX Draw clip polygons around text
	NOBX Do not draw clip polygons around text

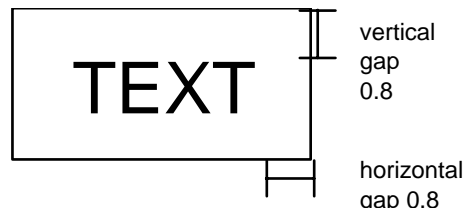
◇ *Field 2 is only relevant if Field 1 is set to POLY.*

Field 3	Text box style name
Field 7	Horizontal gap The horizontal gap is expressed as a ratio of text height (default 0.5)
Field 10	Vertical gap The vertical gap is expressed as a ratio of text height (default 0.5)

### Example

The following example shows a clip polygon with a vertical and horizontal gap of 0.8 placed around a text string.

819 , POLY , NOBX , 7=0.8 , 10=0.8



For further examples of the use of this option, refer to major option CLIP.

## Draw Frames and Grids

This series of options draws frames around the sheet boundary and drawing windows, register marks for accurate registration of overlaid drawings and grids within drawing windows.

821            Add a drawing frame.

822            Add a grid.

The options use the current drawing environment of pen types, colours, line styles and character styles. By repeated use of these options and the drawing environment options complex gridding and framing patterns can be achieved.

### Minor option 821    Add a drawing frame

If omitted the installation default frame is drawn.

Frames can be drawn using the current linestyle to surround the sheet boundary. Where multiple sheets are drawn each will be framed. Frames can also be drawn to surround the drawing window where margins have been defined. Where there are multiple windows per sheet, as in the case of long and cross section drawings, each window will be framed.

This option can draw register marks outside the window boundary for the registration of successive layers of information, which is particularly useful where final drawings are produced by multicolour offset lithography or a similar process.

It is not necessary to frame the sheet boundary of an A0 drawing if a physical A0 sheet will be used in the production of a drawing.



Input

Graphics

IGDRAWT.DAT, DRW006, DRW007, DRW008

Add drawing details	Grids/Frames	Add a drawing frame
Annotation	Add a drawing frame	Drawing frame selected
Draw cadastral symbols	Add a drawing window	Label
Hatching	Add registration marks	
Grids/Frames	Add a FULL grid	
Text strings	Add a CROS grid	
Draw selected strings	Add an EDGE grid	
Draw null/zero levels	Add a macrosymbol grid	
Draw contour strings	End DRAW	
Triangulation options		
Draw drainage network		

IGDRAWT.DAT, DRW006, DRW007, DRW009

Add drawing details	Grids/Frames	Add a drawing window
Annotation	Add a drawing frame	Add a drawing window
Draw cadastral symbols	Add a drawing window	Label
Hatching	Add registration marks	
Grids/Frames	Add a FULL grid	
Text strings	Add a CROS grid	
Draw selected strings	Add an EDGE grid	
Draw null/zero levels	Add a macrosymbol grid	
Draw contour strings	End DRAW	
Triangulation options		
Draw drainage network		

**IGDRAWT.DAT, DRW006, DRW007, DRW010**

<b>Add drawing details</b>	<b>Grids/Frames</b>	<b>Add registration marks</b>
Annotation	Add a drawing frame	Regist'n markers selected
Draw cadastral symbols	Add a drawing window	Label
Hatching	Add registration marks	
<b>Grids/Frames</b>	Add a FULL grid	
Text strings	Add a CROS grid	
Draw selected strings	Add an EDGE grid	
Draw null/zero levels	Add a macrosymbol grid	
Draw contour strings	End DRAW	
Triangulation options		
Draw drainage network		

Linemode

**Minor option 821**

- Field 1      FRAM draw frame around sheet boundary(s) using current linestyle.  
                   WIND draw frame around drawing window(s) using current linestyle.  
                   Note that if the margin width has been set to zero using 802 this will have the same effect as FRAM.  
                   REGR draw registration marks outside the sheet boundary.  
                   NOFR no frame required.  
                   Blank use the installation default.
- Field 3      Picture element label  
                   See Object and Element referencing - page 3 - 80.

**Minor option 822    Add a grid**

Draw a grid within the current drawing window(s).  
 If omitted the installation default grid type will be drawn. Grids will be drawn using the current default linestyle (solid line, dashed line or macroline) or with crosses or macrosymbols at each grid intersection point or with edge marking only. Repeated use of 822 and the drawing environment options allows changes of linestyle, colour, and grid spacing, to produce complex gridding patterns. Grids may be drawn in either or both directions and with or without associated annotation.

Input

Graphics

IGDRAWT.DAT, DRW006, DRW007, DRW011

Add drawing details	Grids/Frames	ADD a FULL grid
Annotation	Add a drawing frame	Grid selected
Draw cadastral symbols	Add a drawing window	Label
Hatching	Add registration marks	Horizontal grid interval
Grids/Frames	Add a FULL grid	Vertical grid interval
Text strings	Add a CROS grid	
Draw selected strings	Add an EDGE grid	
Draw null/zero levels	Add a macrosymbol grid	
Draw contour strings	End DRAW	
Triangulation options		
Draw drainage network		

IGDRAWT.DAT, DRW006, DRW007, DRW012

Add drawing details	Grids/Frames	Add a CROS grid
Annotation	Add a drawing frame	Grid selected
Draw cadastral symbols	Add a drawing window	Label
Hatching	Add registration marks	Horizontal grid interval
Grids/Frames	Add a FULL grid	Vertical grid interval
Text strings	Add a CROS grid	
Draw selected strings	Add an EDGE grid	
Draw null/zero levels	Add a macrosymbol grid	
Draw contour strings	End DRAW	
Triangulation options		
Draw drainage network		

IGDRAWT.DAT, DRW006,DRW007,DRW013

Add drawing details	Grids/Frames	Add an EDGE grid
Annotation	Add a drawing frame	Grid selected
Draw cadastral symbols	Add a drawing window	Label
Hatching	Add registration marks	Horizontal grid interval
Grids/Frames	Add a FULL grid	Vertical grid interval
Text strings	Add a CROS grid	
Draw selected strings	Add an EDGE grid	
Draw null/zero levels	Add a macrosymbol grid	
Draw contour strings	End DRAW	
Triangulation options		
Draw drainage network		

IGDRAWT.DAT, DRW006,DRW007,DRW014

Add drawing details	Grids/Frames	Add a macrosymbol grid
Annotation	Add a drawing frame	Macrosymbol name
Draw cadastral symbols	Add a drawing window	Label
Hatching	Add registration marks	Horizontal grid interval
Grids/Frames	Add a FULL grid	Vertical grid interval
Text strings	Add a CROS grid	Width of macrosymbol
Draw selected strings	Add an EDGE grid	Height of macrosymbol
Draw null/zero levels	Add a macrosymbol grid	
Draw contour strings	End DRAW	
Triangulation options		
Draw drainage network		

- ◇ *If a grid interval is left blank, it will not be drawn (hence just the horizontal or vertical grid can be drawn).*
- ◇ *If an interval is negative, the annotation is not drawn.*

Linemode

Minor option 822

Field 1	Grid type	
	NOGR	Omit grid (default)
	FULL	Draw line grid with interval numbering using current line style and text style.
	CROS	Draw crosses at grid intersections and interval numbers at edges.
	EDGE	Draw edge ticks and interval numbers.

or

- Field 1 & 2    Macrosymbol name.  
                  Draws a macrosymbol at each grid intersection point and draw grid interval numbers.
- Field 3        Picture element label  
                  See Object and Element referencing - page 3 - 80.
- Field 5        Horizontal grid interval in model units.  
                  Leave blank to omit horizontal grid. Code negative interval to suppress annotation.
- Field 6        Vertical grid interval in model units.  
                  Leave blank to omit vertical grid. Code negative interval to suppress annotation.  
                  For a plan drawing:  
                  5 = Easting, 6 = Northing  
                  For a long section:  
                  5 = Distance, 6 = Level  
                  For cross section:  
                  5 = Offset, 6 = Level.

If 'FULL' or 'CROS' or 'EDGE' is coded in field 1 but fields 5 and 6 are both left blank no grid will be produced. Only FULL or EDGE can be used for selective drawing of the grid since for CROS the relevant spacing would not be coded. However, the effect can be achieved with CROS by coding both field 5 and 6 and requesting a very small tick size in either of fields 8 and 9 as appropriate.

#### Cross type grid (CROS)

- Field 8        Horizontal tick mark size in current linear measure units.  
Field 9        Vertical tick mark size in current linear measure units.

#### Macrosymbol grid

- Field 8        Horizontal dimension of macrosymbol cms or inches.  
Field 9        Vertical dimension of macrosymbol cms or inches.

### Examples

```
805, GREEN
810, DASH, 5=0.1, 0.1, , 0.1, 0.1
822, FULL, 5=100, 100
805, BLACK
810
822, CROS, 5=10, 10
```

### Minor option 825 - 830 Draw strings

A number of 825 and/or 826 options may be invoked during any one entry to the major option, particularly following changes to line style or colour.

- 825 Draw all strings in a model or those satisfying a mask table. Various types of standard detail interpretation are provided to minimise data entry. This option applies to plan drawing only.
- 826 Draw a string or all strings satisfying a mask table using the current linestyle. This option is used for both plan and section drawings.
- 827 Draw triangulation. Various types of annotation may also be included.
- 828 Draw drainage network
- 829 Draw drainage section
- 830 Draw text strings

### Minor option 825 Draw selected strings

Draw a string, all the strings in a model or all strings satisfying a predefined mask table. Strings may be drawn using a variety of annotation. This option only applies to plan drawings.

#### Input

#### Graphics

IGDRAWT.DAT, DRW006,DRW015,DRW016

Add drawing details	Draw selected strings	Draw selected strings
Annotation	Full/partial label	String Label/Mask
Draw cadastral symbols	List initial characters	Drawing interpretation (T)
Hatching	List strings	Label descriptor
Grids/Frames		Pip length/Annotation freq
Text strings		Marking interval
Draw selected strings		Contour interval/Text angl
Draw null/zero levels		Start chainage / X coord
Draw contour strings		Start point no. / Y coord
Triangulation options		End chainage / X coord
Draw drainage network		End point no. / Y coord

Drawing Interpretation: toggles between DETA and PIPS, ARRO, LEVS etc. Full details of the meaning of each code is included in the Linemode section below.

Linemode

Once the drawing window, the drawing environment and the framing are complete, strings can be drawn in the drawing window using the following options.

A number of alternatives is provided.

**Minor option 825**

**Use predefined detail interpretation**

- |             |  |
|-------------|--|
| Field 1     | String label if only one string is to be drawn. Partial mask if a set of strings is to be drawn. Care should be taken when mixing this style of masking with option 019 style.<br>If this field is left blank all strings satisfying the 019 selection masks will be drawn.  |
| Field 2     | DETA The standard detail interpretation based on the first character of each string will be drawn. The standard detail is installation dependent.  |
| Field 3     | Annotation to be drawn<br>LABL draw the string label at both ends of the string.<br>LABS draw the string label at the start of the string.<br>LABA draw the string label with a directional arrow at both ends of the string.<br>ARRO draw a directional arrow at both ends of the string.<br>LEVS for contours draw the level only at the start of the string and draw all other strings as NOLA.<br>LEVB for contours draw the level only at both ends of the string and all other strings as NOLA.<br>NOLA do not draw string labels. |
| Field 4     | Pip length used for marking chainage on (M) master alignment strings.  |
| Field 5 & 6 | SPRD for start.  |
| Field 7     | Chainage marking interval for master alignment (M) strings. Note that chainages will appear at integer multiples of this value, irrespective of start chainages.   |
| Field 8 & 9 | SPRD for end of string.  |

**Draw pips on strings**

- |         |  |
|---------|--|
| Field 1 | String label if only one string is to be drawn. Partial mask if a set of strings is to be drawn. Care should be exercised when mixing this style of masking with option 019 style.<br>If this field is left blank all string satisfying the selection masks will be drawn. |
| Field 2 | Pips indicator<br>PIPS draw all strings with pip marks at each string point. The current line style will be used. Point sequence numbers will also be drawn.   |

Field 3	Annotation to be drawn
	LABL draw the string label at both ends of the string.
	LABS draw the string label at the start of the string.
	LABA draw the string label with a directional arrow at both ends of the string
	ARRO draw a directional arrow at both ends of the string.
	LEVS for contours draw the level only at the start of the string and draw all other strings as NOLA.
	LEVB for contours draw the level only at both ends of the string and all other strings as NOLA.
	NOLA do not draw string labels.
Field 4	Pip length. If blank a default value of 1mm will be used.
Field 7	Point sequence number marking interval. If omitted every fifth point will be annotated.

**Draw strings as spot levels**

Field 1	String label if only one string is to be drawn. Partial mask if a set of strings is to be drawn. Care should be exercised when mixing this style of masking with option 019 style. If this field is left blank all string satisfying the selection masks will be drawn.
Field 2	Level indicator
	SPOT draw all strings as a series of points with a cross annotated with the level.
	SPDP draw all strings as level annotation justified by the decimal point.
Field 3	Annotation to be drawn
	LABL draw the string label at both ends of the string.
	LABS draw the string label at the start of the string.
	LABA draw the string label with a directional arrow at both ends of the string
	ARRO draw a directional arrow at both ends of the string.
	LEVS for contours draw the level only at the start of the string and draw all other strings as NOLA.
	LEVB for contours draw the level only at both ends of the string and all other strings as NOLA .
	NOLA do not draw string labels.



**Draw contours as CONT and other strings as SPOT**

Field 1 String label if only one string is to be drawn. Partial mask if a set of strings is to be drawn. Care should be exercised when mixing this style of masking with option 019 style. If this field is left blank all strings satisfying the 019 selection masks will be drawn.

Field 2 LEVE  
Draw all contour strings as described under CONT and all other strings as described under SPOT.

Field 3 Annotation to be drawn

LABL	draw the string label at both ends of the string.
LABS	draw the string label at the start of the string.
LABA	draw the string label with a directional arrow at both ends of the string.
ARRO	draw a directional arrow at both ends of the string.
LEVS	for contours draw the level only at the start of the string and draw all other strings as NOLA.
LEVB	for contours draw the level only at both ends of the string and all other strings as NOLA.
NOLA	do not draw string labels.

**Example**

```
825 , L , SPOT , NOLA
825 , M , DETA , NOLA , 7=1000 . 0
825 , M , PIPS , NOLA
```

**Minor option 825 Draw contour strings**

Draw a contour string, all the contour strings in a model or all contour strings satisfying a predefined mask table. Strings may be drawn using a variety of annotation. This option only applies to plan drawings.

Input

Graphics

IGDRAWT.DAT, DRW006,DRW052,DRW051

Add drawing details	Draw contour strings	Draw contour strings
Annotation	Full/partial label	String label/mask
Draw cadastral symbols	List initial characters	Contour interpretation (T)
Hatching	List strings	Label descriptor
Grids/Frames		Annotation frequency
Text strings		Local origin / Start point X
Draw selected strings		Local origin / Start point Y
Draw null/zero levels		Embedding code
Draw contour strings		End point X (CONL only)
Triangulation options		End point Y
Draw drainage network		Text angle

Contour Interpretation: toggles between CONT and CONP, COND, CONX etc. Full details of the meaning of each code is included in the Linemode section below.

Linemode

Minor option 825

Field 1 String label if only one string is to be drawn. Partial mask if a set of strings is to be drawn. Care should be exercised when mixing this style of masking with option 019 style. If this field is left blank all strings satisfying the 019 selection masks will be drawn.

Field 2 Level indicator

CONT Contour level drawn at start and end of string.

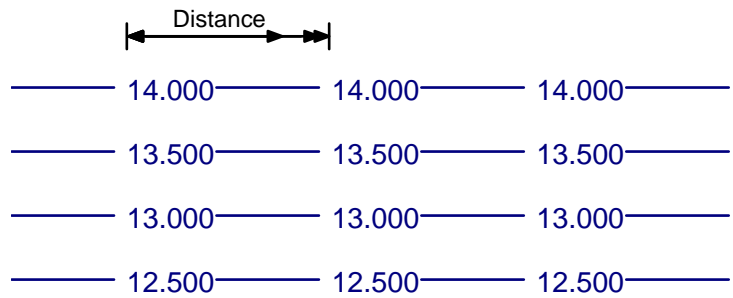
CONP Contour levels drawn beginning on every nth point.

COND Contour levels drawn at a regular spacing defined by the cumulative straight line distance along a string.

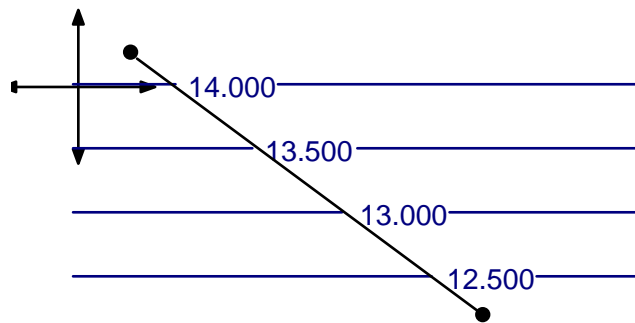
CONX Contour levels drawn at a regular spacing defined by a set distance along the X axis from a local origin.

CONY Contour levels drawn at a regular spacing defined by a set distance along the Y axis from a local origin.

CONL Contour levels drawn beginning at the intersection between the contours and a defined line.

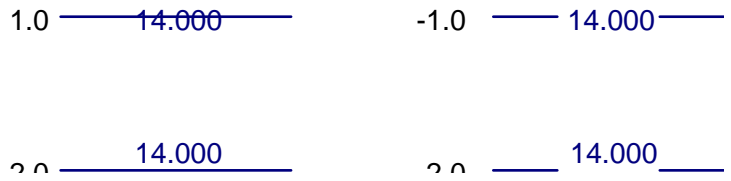


COND - Annotation embedded at distance interval



CONL - Annotation at intersection with a defined line

- Field 3 Annotation to be drawn.
- LABL draw the string label at both ends of the string.
  - LABS draw the string label at the start of the string.
  - LABA draw the string label with a directional arrow at both ends of the string.
  - ARRO draw a directional arrow at both ends of the string.
  - LEVS for contours draw the level only at the start of the string and draw all other strings as NOLA.
  - LEVB for contours draw the level only at both ends of the string and all other strings as NOLA.
  - NOLA do not draw string labels.
- Field 4 Frequency of annotation for CONP, COND, CONX, CONY.  
For COND, this is the distance, in model units, between each embedded value.
- Field 5 & 6 Local origin for CONX, CONY, start point of line CONL.
- Field 7 Level style
- 1.0 embed the annotation without a gap
  - 1.0 embed the annotation with a gap
  - 2.0 embed the annotation and its inverse image without a gap
  - 2.0 embed the annotation and its inverse image with a gap
- Default is -1.0, no image with a gap.



Field 8 & 9 End point of line for CONL.  
 Field 10 Angle of text  
 If the angle is positive, text is positioned measured clockwise relative to the left hand side of the drawing. If negative, text is positioned clockwise relative to the normal lying to the left of the string.

◇ *As Fields 5, 6, 8, 9 are used for contour annotation, no SPRD is possible.*

**Example**

825, 0, CONT, NOLA, 10=200.0

**Minor option 825 Draw null/zero levels**

Draw string links having a null or zero level at either end in a selected colour.

**Input**

**Graphics**

IGDRAWT.DAT, DRW006 DRW055 DRW056

Add drawing details	Draw null/zero levels	Draw null/zero levels
Annotation	Full/partial label	String label/mask
Draw cadastral symbols	List initial characters	Null interpretation (T)
Hatching	List strings	Start chainage / X coord
Grids/Frames		Start point no. / Y coord
Text strings		Null colour (T)
Draw selected strings		End chainage / X coord
Draw null/zero levels		End point no. / Y coord
Draw contour strings		
Triangulation options		
Draw drainage network		

Linemode

Minor option 825

- Field 1      String label if only one string is to be drawn. Partial mask if a set of strings is to be drawn.  
Care should be exercised when mixing this style of masking with option 019 style.  
If this field is left blank all strings satisfying the 019 selection masks will be drawn.
- Field 2      Null/zero level indicator
- NCOL      Draw string links having a null level at either end in the default colour or the colour defined by a preceding minor option 805. All links are drawn.
- ZCOL      Draw string links having a zero level at either end in the default colour or the colour defined by a preceding minor option 805. All links are drawn.
- NULL      Draw only string links having a null level at either end in the default colour or the colour defined by a preceding minor option 805. String links with zero or other defined levels are not drawn.
- ZERO      Draw only string links having a zero level at either end in the default colour or the colour defined by a preceding minor option 805. String links with null or defined levels are not drawn.
- Field 5 & 6    SPRD for start.
- Field 8 & 9    SPRD for end.
- ◇ *If field 2 is coded NCOL, ZCOL, NULL or ZERO the string links drawn will use the colour defined by minor option 805.*
  - ◇ *Null or zero levels can also be annotated using a macrosymbol. See minor option 861, 'Macrosymbol at string points' for further details.*

**Minor option 826    Draw string or set of strings**

Draw a string or set of strings using the current linestyle.

This option will draw all of the string appearing in the drawing window(s) and is used for plan, long and cross section plots.

## Plan drawing

### Input

#### Linemode

#### Plan drawing

##### Minor option 826

- |             |   |
|-------------|---|
| Field 1     | Label of string to be drawn<br>or Mask to select all strings to be drawn.<br>or Blank in which case all strings will be drawn that satisfy the current mask table (if any).   |
| Field 3     | Annotation to be drawn<br>LABL draw the string label at both ends of the string.<br>LABS draw the string label at the start of the string.<br>LEVS for contours draw the level only at the start of the string other string drawn as NOLA.<br>LEVB for contour strings draw the level only at both ends of the string. Other strings draw as NOLA.<br>NOLA do not draw string labels. |
| Field 5 & 6 | SPRD for start of string to be drawn, if omitted the start of the string is assumed.  |
| Field 8 & 9 | SPRD for end of string to be drawn, if omitted the end of the string is assumed.  |
- ◇ *If a geometry string label is specified, the geometry string points drawn are those indicated by minor option 809, 'Geometry string annotation'.*

### Example

```
THIS WILL DRAW STRING M001 IN A RED DASHED LINE
805,RED
810,DASH,5=0.5,0.5,0.0,0.5,0.5
826,M001,5=100,8=900
```

## Long section drawing

### Input

#### Linemode

#### Long section drawing

##### Minor option 826

- |         |  |
|---------|--|
| Field 1 | Label of string to be drawn.   |
| Field 2 | Label of string from which normals are erected to define extents of string to be drawn. If omitted string in field 1 is assumed. |
| Field 3 | LABL draw string labels.   |

- Field 5 & 6 SPRD for start of string to be drawn, if omitted the start of the string is assumed.
- Field 7 Dimension of string to be drawn on the vertical axis, default is 3 (level).
- Field 8 & 9 SPRD for end of string to be drawn, if omitted the end of the string is assumed.
- ◇ *If a geometry string label is specified, the geometry string points drawn are those indicated by minor option 809, 'Geometry string annotation'.*

### Example

```

      THIS WILL DRAW STRING L001 AS A BLUE SOLID LINE
805, BLUE
810
826, L001, , NOLA
      OVERLAID ON THIS WILL BE M001 AS A BLACK DASHED
      LINE
805, BLACK
810, DASH, 5=0.5, 0.5, 0.0, 0.5, 0.5
826, M001, , NOLA

```

## Cross section drawing

### Input

#### Linemode

#### Cross section drawing

##### Minor option 826

- Field 1 Section set reference letter in Column 1.
- Field 3 Label drawing indicator
  - LABL draw string labels.
  - NOLA no string labels drawn.
- Field 4 Interval for cross sections to be drawn.
  - If the reference string used to generate the cross section was a master alignment, this field would contain a chainage interval which must be a multiple of the original chainage interval.
  - If the reference string was a three dimensional string, the section nearest to the multiple of the selection interval is drawn.
  - If the selection interval is negative it is assumed to be a point number interval eg. -2 would mean draw every other section.
- Field 5 & 6 SPRD for first section to be drawn, if omitted the first section is assumed.
- Field 8 & 9 SPRD for last section to be drawn, if omitted the last section is assumed.

Example

826, R, 4=100

Minor option 827 Draw triangulation

This minor option allows you to draw and annotate a triangulated model generated by major option TRIANGLE. The annotation that may be automatically generated is -

- crosses at triangle centroids
- levels at triangle centroids or vertices
- arrows at the triangle centroids indicating the direction of maximum gradient.

Input

Graphics

IGDRAWT.DAT, DRW006, DRW036, DRW037

Add drawing details	Draw triangulation	Draw triangulation
Annotation	Draw triangulation	Triangulation label
Draw cadastral symbols	Fill triangulation	Annotation descriptor (T)
Hatching	End DRAW	Group name/NULL/UNGP
Grids/Frames		Draw triangles (T)
Text strings		
Draw selected strings		
Draw null/zero levels		
Draw contour strings		
Triangulation options		
Draw drainage network		

**Annotation descriptor:** You can use this toggle to select one of the following CENT = crosses at triangle centroids, LEVC = levels at triangle centroids, LEVV = levels at triangle vertices, or FLOW = arrows at triangle centroids indicating the direction of maximum gradient.

**Draw triangles:** You can use this toggle to select either, 1.0 = draw triangles or, -1.0 = draw only annotation.

**Level annotation:** text is related to the current text size and style. Where levels are written at the triangle centroid, the decimal point of the level value indicates the centroid.



Linemode

- 1st model Model containing strings to be drawn or model containing triangulation label if the model is a .TRIA type.
- Minor option 827**
- \* Field 1 Triangulation label
  - Field 2 Annotation to be drawn
    - CENT draw crosses at triangle centroids
    - LEVC draw levels at triangle centroids
    - LEVV draw levels at triangle vertices
    - FLOW draw arrows at triangle centroids in the direction of maximum gradient.
  - Field 3 Triangles to be drawn
    - Group draw only the triangles that are within the specified group.
    - NULL draw only null triangles
    - UNGP draw only ungrouped triangles.
  - Field 4 Triangle/annotation indicator
    - 1 draw triangulation (default).
    - 1 draw annotation only.

Examples

Draw null triangles as a check before passing to visualisation. This eliminates the possibility of producing inconsistencies in the surface when visualised.

827, TRIA, , NULL,

Draw all triangles in the group 'GRAS' with flow arrows.

827, TRIA, FLOW, GRAS

Draw all triangles with levels at centroids and at triangle vertices.

827, TRIA, LEVC

827, TRIA, LEVV, 4=-1

Draw all triangles in red, centroid crosses in green and centroid levels in cyan.

805, RED

806, CYAN

827, TRIA, LEVC

805, GREEN

827, TRIA, CENT, 4=-1

**Minor option 828 Draw drainage network**

This minor option allows you to draw and annotate a drainage model generated by major option DRAINAGE. Line styles and annotation may be automatically applied to pipes, manholes and gullies.

Input

Graphics

IGDRAWT.DAT, DRW006, DRW045

Add drawing details	Draw drainage network
Annotation	Label/mask
Draw cadastral symbols	Drawing interpretation (T)
Hatching	Network labelling (T)
Grids/Frames	Manhole/gully size
Text strings	
Draw selected strings	
Draw null/zero levels	
Draw contour strings	
Triangulation options	
Draw drainage network	

**Drawing interpretation:** may be toggled between DETA, SYMB and blank.

**Network labelling:** may be toggled to annotate each pipe, manhole or gully with appropriate information.

Linemode

Minor option 828

- Field 1 Drainage string label. If blank all strings will be drawn.
- Field 2 Code DETA for standard detail interpretation  
Code SYMB for (manhole) symbol according to string data.
- Field 3 Code ANNO for standard annotation
- Field 4 Manhole/gully size in drawing units.

◇ *To use DETA and SYMB standard drainage macros DRAINSY1, DRAINSY2, DRAINSY3 and DRAINSY4 must be present in the macro library.*

Examples

Draw all pipes (label initial character S) in the current line style and colour.

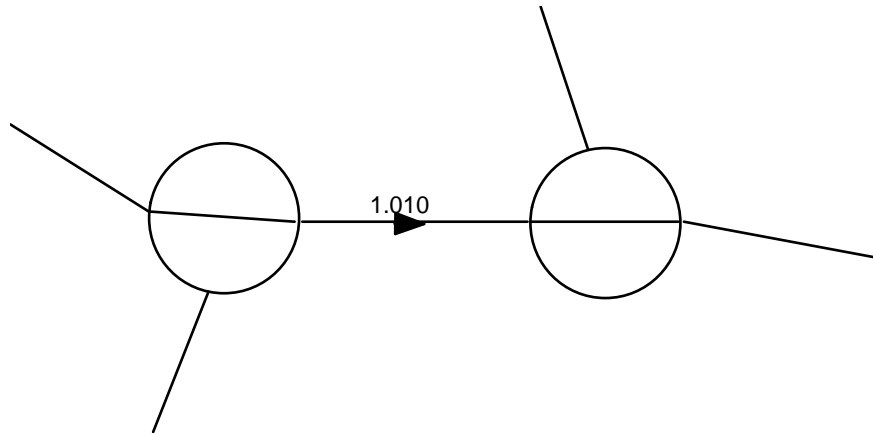
```
DRAW, DRAINAGE NETWORK
828, S
```

Draw all pipes (label initial character S) linking the main branch across manholes.

```
DRAW, DRAINAGE NETWORK
828, S, DETA
```

Draw all pipes (label initial character S) annotating each pipe with its pipe number and flow direction.

DRAW, DRAINAGE NETWORK  
828, S, DETA, ANNO



**Figure 3 - 120 Pipes with standard detail interpretation and annotation**

Draw manholes (on point string PMAN) using standard detail interpretation and coded size.

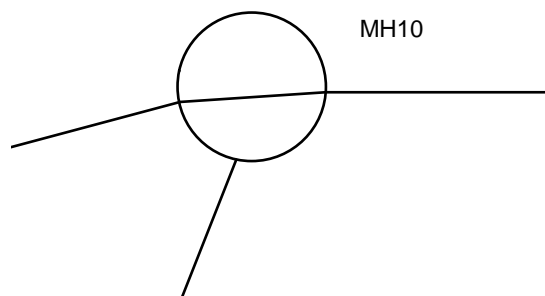
DRAW, DRAINAGE NETWORK  
828, PMAN, DETA, 4=0.5

Draw manholes using standard detail interpretation scaled to the actual or equivalent stored diameter.

DRAW, DRAINAGE NETWORK  
828, PMAN, DETA

Draw manholes using the standard detail interpretation scaled to the actual or equivalent stored diameter, and annotating with the manhole label.

DRAW, DRAINAGE NETWORK  
828, PMAN, DETA, ANNO



**Figure 3 - 121 Manholes with standard detail interpretation and annotation**

Draw manholes using the stored dimensions.

DRAW, DRAINAGE NETWORK

828, PMAN, SYMB

To draw gullies (label PGUL) using the square gully symbol, using the coded size, and with a pipe link to outfall.

DRAW, DRAINAGE NETWORK

828, PGUL, 4=0.5

To draw all gullies using standard detail interpretation.

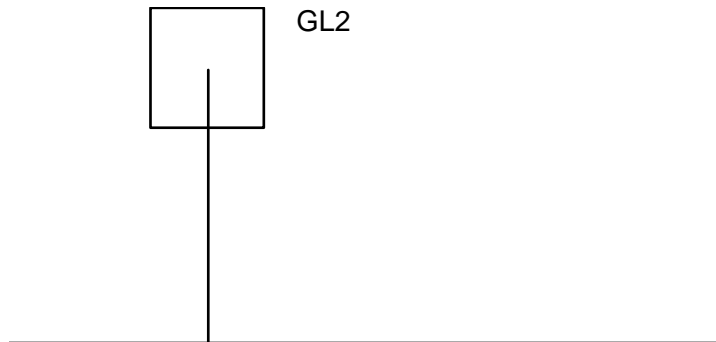
DRAW, DRAINAGE NETWORK

828, PGUL, DETA

To draw gullies using standard detail interpretation, using the stored dimensions, and annotating the gully with its label.

DRAW, DRAINAGE NETWORK

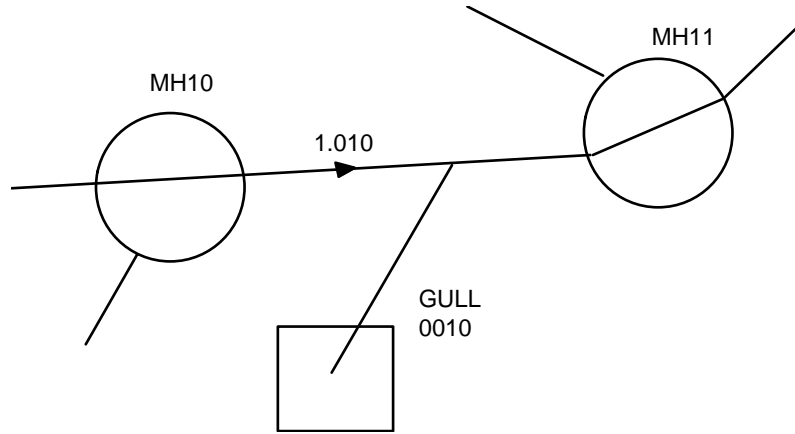
828, PGUL, DETA, ANNO



**Figure 3 - 122 Gully with standard detail interpretation and annotation**

Draw whole network with detail interpretation and annotation

828, , DETA, ANNO



**Figure 3 - 123 Whole drainage network with detail interpretation and annotation**

### Minor option 829 Draw drainage section

This minor option allows you to draw and annotate as a section drawing a drainage model generated by major option DRAINAGE. Line styles and annotation may be automatically applied to pipes and manholes.

◇ *This option is only available in linemode or through a command macro.*

#### Input

##### Linemode

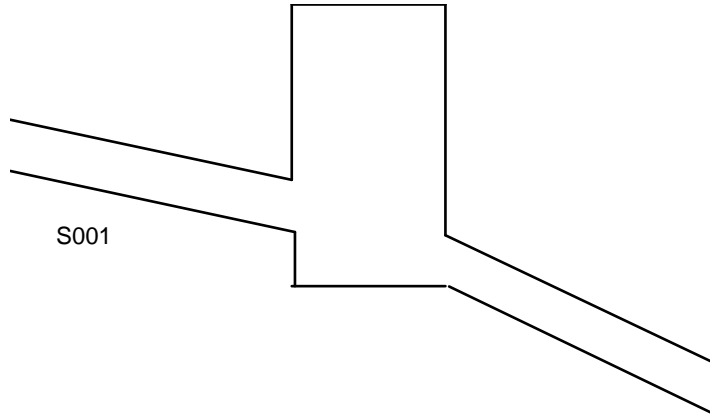
#### Minor option 829

- \* Field 1 Pipe string label or  
Manhole string label (PMAN)
- Field 2 Annotation to be drawn  
DETA Pipes are drawn between string points and scaled according to pipe dimensions.  
Manholes are drawn as scaled manhole symbols with a vertical pipe between the cover and invert levels.
- Field 4 Base of manhole drawing style  
0 = flat (default)  
1 = slope

#### Examples

Figure 3 - 124 shows a manhole drawn with a flat base.

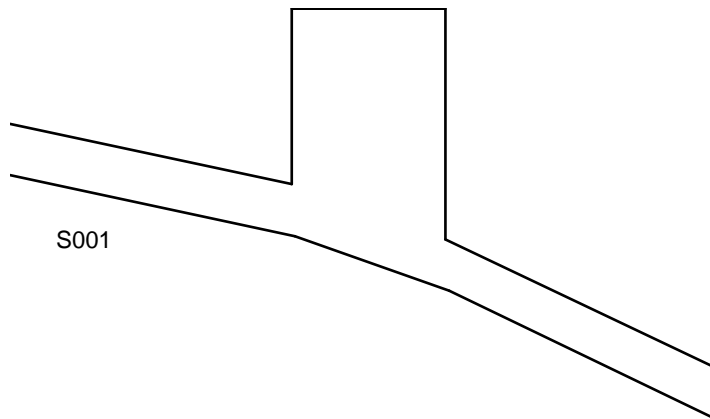
829, S001, DETA, 4=0



**Figure 3 - 124 Manhole - flat base**

Figure 3 - 125 shows a manhole drawn with a sloping base.

829 , S001 , DETA , 4=1

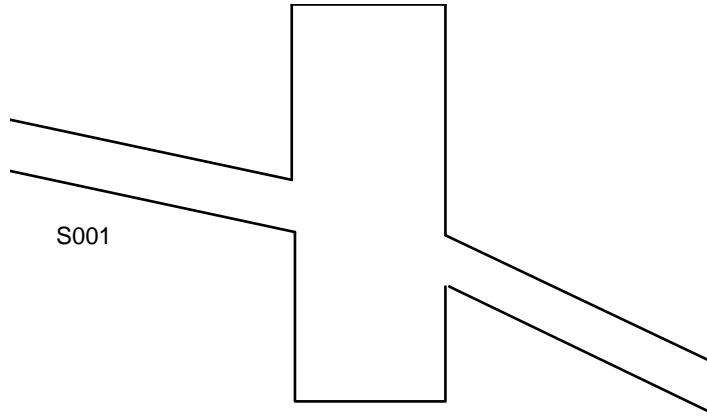


**Figure 3 - 125 Manhole - sloping base**

Figure 3 - 126 shows a manhole with sump.

829 , S001 , DETA , 4=1

Note field 4=1 (flat/sloped base) is ignored whenever a manhole with a sump is to be drawn



**Figure 3 - 126 Manhole with sump**

Blank Pipes and manholes are drawn as single lines  
 Field 3 Pipe string label. Code only if Field 1 contains a manhole string label.

### Minor option 830 Draw text strings

Text strings are stored with a label starting with \* and can hold several sets of text each associated with a different model coordinate. Text strings contain a bearing and a character height which can be overridden by this option. All other parameters will be taken from the current character style.

#### Input

#### Graphics

IGDRAWT.DAT, DRW006, DRW017

Add drawing details	Text strings
Annotation	String label
Draw cadastral symbols	Start chainage / X coord
Hatching	Start point no. / Y coord
Grids/Frames	Character height
<b>Text strings</b>	End chainage / X coord
Draw selected strings	End point no. / Y coord
Draw null/zero levels	Bearing of text
Draw contour strings	
Triangulation options	
Draw drainage network	

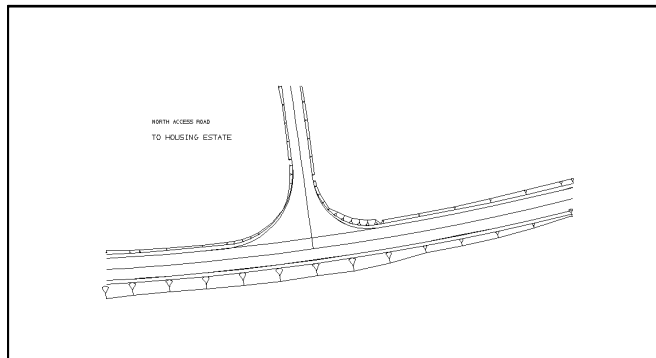
Linemode

Minor option 830

Field 1	Label of text string to be drawn must start with * Mask to select all strings to be drawn must start with * Blank - assumes all text strings (starting with *)
Field 2	Blank - use character height and angle from text string.
Field 6	Point no. of first point on text string to be drawn, if omitted the start is assumed.
Field 7	Character height in current linear measure units, overrides the value stored in the string.
Field 9	Point number of last point on text string to be drawn, if omitted the end is assumed.
Field 10	Bearing of the base of the characters, overrides the value stored in the string.

Examples

830 , \*DT1  
830 , \*DT2 , 7=0.2



**Figure 3 - 127 Example - DRAW text strings**

**Minor option 831 Draw raster backcloth**

Draw a monochrome raster image for use as a backcloth.

The image to be drawn must be in TIFF packbits or TIFF uncompressed format, and must be in orthogonal (or rectified) form calibrated to real world coordinates. This can be achieved in one of two ways.

- The image can be rectified and calibrated using a raster pre-processor package
- An image already rectified can be calibrated by specifying the real world coordinate information on the 831 option.



The special model name RASTER is used on entry to major option DRAW to indicate that a raster backcloth is to be drawn rather than model information.

Up to ten images may be drawn using separate minor option records and multiple images may be overlaid or tiled in a single Raster Picture File (.RPF). Images drawn together must have the same resolution, which is specified in terms of dots per unit.

If required, the backcloth can be overdrawn with ordinary model information on the same sheet. If a new sheet is created, both the RPF and the DPF will be overwritten if new raster and model information is drawn.

Images may be overlaid or placed side by side on the drawing sheet.

## Input

### Graphics

IGDRAWT.DAT, DRW003, DRW058

DRAW - Option details	Raster calibration
Model for DRAW	Raster image file
Draw all strings	Resolution X
Draw all strings (DETA)	Resolution Y
Draw selected strings	Bottom left corner X
Draw raster backcloth	Bottom left corner Y
Draw using a macro	Top right corner X
Define a boundary	Top right corner Y
Add drawing details	
Create new sheet	
End DRAW	

### Linemode

#### Minor option 831

- \* Field 5, 6 Bottom left corner coordinates
- Field 7 Resolution in pixels per unit in the X direction
- Field 8 & 9 Top right corner coordinates
- Field 10 Resolution in pixels per unit in the Y direction

◇ *Field 7 is the default.*

◇ *Enter data in either Fields 7, 7 & 10 or 8 & 9.*

The name of the file containing the image to be drawn must be specified in a subsequent 001 record.

#### Minor option 001

Name of file containing the image in TIFF format.

- ◇ *The default file extension used for image files is .tif*
- ◇ *For each .tif image file specified, there must be a corresponding .sup file containing calibration information unless the calibration information is specified in the option.*
- ◇ *The default RPF name is draw.rpf.*
- ◇ *If more than one image is to be drawn, they must all be drawn within the same major option.*
- ◇ *The only valid minor options when model name RASTER is specified are 800, 801, 802, 803, 805 and 831.*
- ◇ *Multiple, rotated and composite sheets are not allowed.*

### Examples

Typical backcloth images might be a 1:10000 map sheet The map and overlay are scanned and converted to TIFF format by a raster preprocessing program so that they are ready for use by MOSS.

The file name used is backmap.tif.

```

1. BY TOP AND BOTTOM COORDINATES
DRAW, RASTER
803,7=110 000
831,5=501000,114000,,521000,134000
001,backmap
999

```

```

2. BY RESOLUTION AND BOTTOM LEFT HAND COORDINATES
DRAW, RASTER
803,7=10 000
831,5=501000,114000,1.2
001,backmap
999

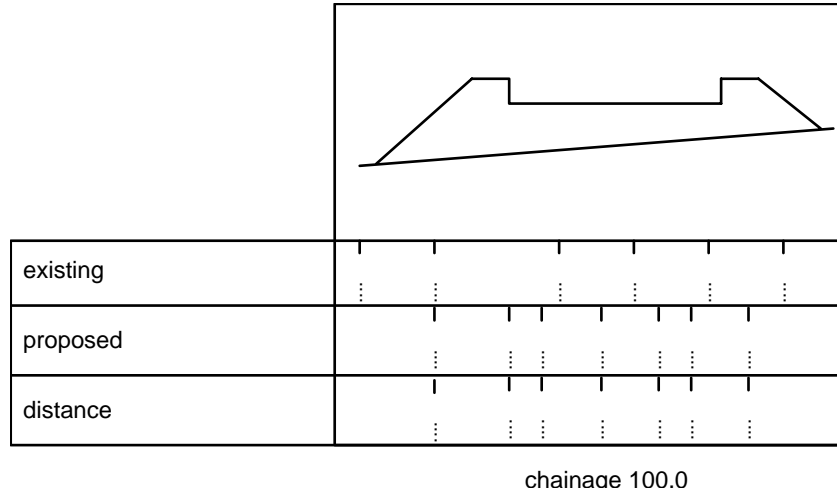
```

- ◇ *The model and image(s) may be drawn in any order.*
- ◇ *The image drawn last appears as the top raster layer.*

**Minor option 845 - 849 Axes and axis annotation**

These options relate only to long and cross sections

The structure of a section object is an aggregation of strings, axes and other annotation areas. The diagram below is typical.



**Figure 3 - 128 Example - Section object structure**

The following minor options deal with the layout and content of the annotation areas.

- 845 Define position and size of an annotation area and optionally draw boundary lines.
- 846 Draw annotation derived from a string in an annotation area.
- 847 Draw a text string in an area.
- 848 Define a text string with variable components derived from other strings.
- 849 Draw ordinates from an axis to a string.

The section 'Drawing concepts' fully describes the use of these options.

**Minor option 845 Define annotation area**

Define the size and position of an annotation area.

A reference point is defined at one of the corners of the section object window and all dimensions are relative to the reference point.

**Input**

## Linemode

## Minor option 845

Field 1	Column 1	
	B	draw complete box
	L	draw a line
	Column 2	
		Position of the annotation box on section window
	T	Top
	B	Bottom
	Column 3	
		Position of the annotation box on section window
	L	Left
	R	Right
	C	position at zero offset point
		If this field is omitted, the reference point is bottom left corner, and the area outline is not drawn.
	Column 4 (used in conjunction with L in column 1)	
	B	draw a line along the bottom of the defined annotation area.
	T	draw a line along the top.
	L	draw a line along the left hand side
	R	draw a line along the right hand side.
Field 2	Axis annotation positioning.	
	Column 1	
	T	Place annotation abutting the top of the box.
	B	Place annotation abutting the bottom of the box.
	C	Centre the annotation vertically.
	Column 2	
	L	Left justify the annotation.
	R	Right justify annotation.
	C	Centre the annotation.
	M	Midway between adjacent points.
	Column 3	
	P	Draw pips at the actual point.
	Blank	No pips drawn.
	Column 4 (Position of pips)	
	L	Left hand side
	R	Right hand side
	T	Top

**B Bottom**

- \* Field 3 Area name, this is used to refer to the area in subsequent options.

A number of alternatives is provided.

**Define area in model units**

Field 5 Horizontal distance of bottom left hand corner of area from reference point in model units. This may be positive or negative.

Field 7 Horizontal length in model units.

Field 8 Vertical distance of bottom left hand corner of area from reference point in model limits. This may be positive or negative.

Field 10 Height of area in model units.

**Define area in drawing units**

Field 6 Horizontal distance of bottom left hand corner of area from reference point in current linear measure units. This may be positive or negative.

Field 7 Horizontal length of area in current linear measure units.

Field 9 Vertical distance of bottom left hand corner of area from reference point in current linear measure units.

Field 10 Height of area in current linear measure units.

- ◇ *If field 5, 6, 7, 8, 9, 10 are omitted the area abuts the base of the section object window, the length of the area is the full length of the drawing window and the height of the area is three times the current character height.*
- ◇ *If field 7 is coded and field 10 is not, the default for field 10 (height of the area) is the height of the drawing window, this allows areas adjacent to the vertical axis to be simply defined. If a value of 0.0 is coded in field 7 and field 10 is left blank, this has the effect of boxing the complete section window.*
- ◇ *If field 10 is coded and field 7 is not, the default for field 7 (length of area) extends to the full drawing window: this allows areas adjacent to the horizontal axis to be simply defined.*

Examples

```

845 , BBL , TCPT , 3=BOX1 , 9=-1.5 , 1.5
845 , BTL , 3=BOX2 , 6=-6 , 6 , 10=3
845 , BBR , 3=BOX3 , 7=6 , 9=1.5 , 3
845 , BBL , CC , BOX4 , 5=100 , 7=100 , 9=-6 , 3
845 , B , , BOSH , 7=0.0

```

would produce the following arrangement.

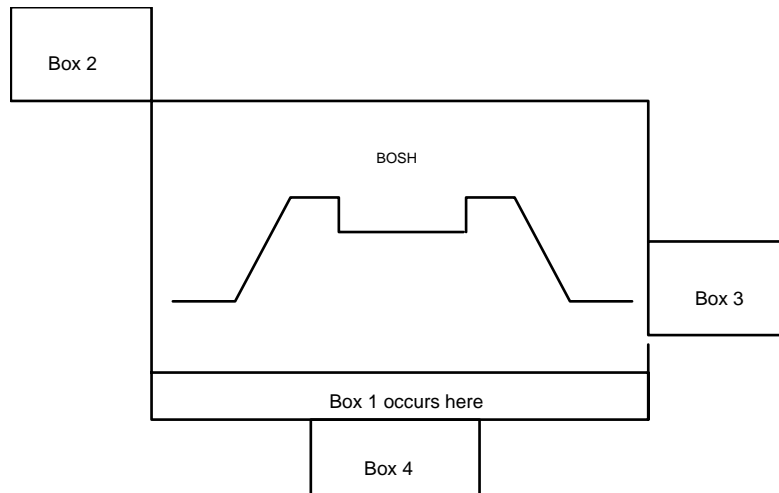


Figure 3 - 129 Example - minor option 845

```

845 , BBL , TCPT , 3=BOX1 , 9=-1.5 , 1.5
845 , BTL , 3=BOX2 , 6=-6 , 6 , 10=3
845 , BBR , 3=BOX3 , 7=6 , 9=1.5 , 3
845 , BBC , CC , BOX4 , 7=6 , 9=-4.5 , 3.0
845 , B , , BOSH , 7=0.0

```

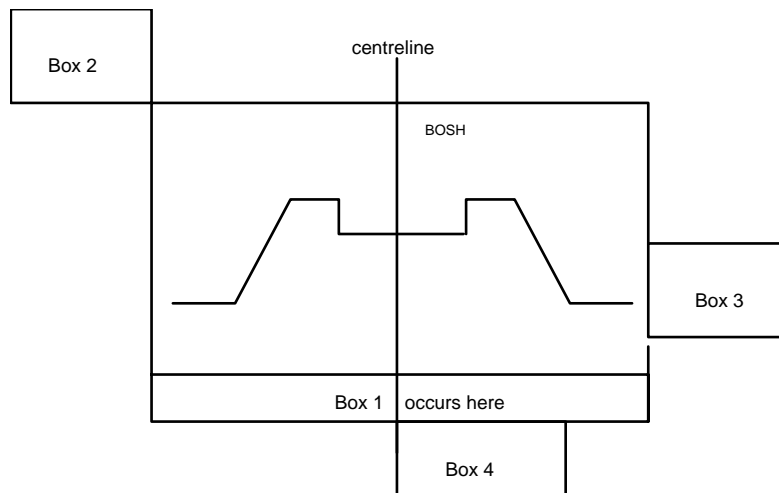


Figure 3 - 130 Example - minor option 845

## Minor option 846 Draw axis annotation

Draw axis annotation in an annotation area.

This option is used to draw values of the independent variable, either chainage or distance for a long section drawing or offset for a cross section drawing.

The dependent variable to be drawn is extracted from a specified dimension of the section string, normally this would be the third dimension (level) but additional facilities allow all other information held in the string index such as the string label, subreference, number of points in the string, and the maximum and minimum x and y values to be drawn. Any of the dimensions within the string element can be drawn; in the case of a section string dimension 4 is the offset distance and dimension 5 is the cut string label. In the case of a master alignment string the instantaneous bearing and radius could be extracted and drawn whilst with an interface string the batter slope width could be extracted and drawn.

The option gives complete control over the frequency and positioning of the annotation within the area, and axis tick marks can be drawn. The current text style is used.

### Input

#### Linemode

#### Minor option 846

- Field 1** For information extracted from a string, code the String Label for three dimensional strings and long section strings or the section set reference letter for cross section strings.
- If left blank the annotation is computed as multiples of the interval given in Field 4. This is used for the independent variable when it cannot be extracted directly from a string (eg when drawing a 3 dimensional string).
- If field 7=-36, two 846 minor options have to be specified. For the first 846 record, code SUPE. For the second 846 record, code the first string for the superelevation calculation, usually the centreline string.
- If field 7=-37, this is the first string for the superelevation calculation, usually the centre line or reference string.
- Field 2** Label of string from which normals are erected to define extent of string to be drawn. If omitted string in field 1 is assumed.
- If field 7=-30.0, -33.0 or -34.0 this string must be a geometry string.
- If field 7=-36, the second 846 record contains the second string for the superelevation calculation, usually a channel string.
- If field 7=-37, this is the second string for the superelevation calculation, usually a channel or offset string.

- \* Field 3 Area name, annotation is placed in this area, previously defined on an 845 option.  
If field 7=-36, the second 846 record contains the third string for the superelevation calculation, usually a channel string.
- Field 4 Interval for the drawing of annotation. If omitted annotation is drawn at all string points. If the string is a Master Alignment, this is taken as the chainage interval, if a 3 dimensional string, interface or section the point nearest to the multiple of this distance is taken.  
If the interval is coded as a negative number it is assumed to be a point number interval, eg -2 means draw annotation at every second string point.  
A reference chainage for distance intervals may be specified on an additional 804 record.
- Field 5 & 6 SPRD for start point of part of string for which annotation is drawn, if omitted the start of the string is assumed.
- Field 7 String dimension to be output eg. 3.0 would give the level, 5.0 would give the cut string label for a section string.  
If a negative value is coded, values can be extracted from the string index or derived values can be drawn as follows:-
  - 1.0 String label
  - 2.0 Subreference
  - 3.0 String contents indicator
  - 4.0 Number of points in string
  - 5.0 Minimum x coordinate in string
  - 6.0 Minimum y coordinate in string
  - 7.0 Maximum x coordinate in string
  - 8.0 Maximum y coordinate in string

Note that the same values would be drawn at every string point

  - 9.0 Datum of profile
  - 11.0 Point sequence number

When using dimensions -21 to -24, M should be coded in column 2, field 2 of the 845 option.

  - 21.0 Distance between adjacent points.
  - 22.0 Cumulative distance between adjacent points (long sections only)
  - 23.0 Percentage gradient between adjacent points
  - 24.0 Level difference between adjacent points
  - 30.0 Geometry string only, horizontal schematic 1 (see Figure 3 - 134)
  - 33.0 Geometry string only, horizontal schematic 4
  - 34.0 Geometry string only, vertical schematic 1



- 35.0 Vertical annotation schematic (see Figure 3 - 133)
- 36.0 Crossfall schematic (see Figure 3 - 132)

When using dimension -36, two 846 records have to be defined in order to obtain the crossfall schematic diagram (Figure 3 - 132), as per the example below.

- 37.0 Superelevation between two strings

◇ *Transitions in schematic diagrams may be represented by 'A' value or 'RL' value according to the setting in the parameter file.*

Field 8 & 9 SPRD for end point of part of string for which annotation is drawn. If omitted, the end of the string is assumed.

Field 10 Angle of annotation measured clockwise relative to the left hand side of the drawing.

◇ *When extracting information from a geometry string, the type of information extracted is indicated by minor option 809, 'Geometry string annotation'.*

For full details of DRAINAGE string dimensions see Chapter 12 Drainage.

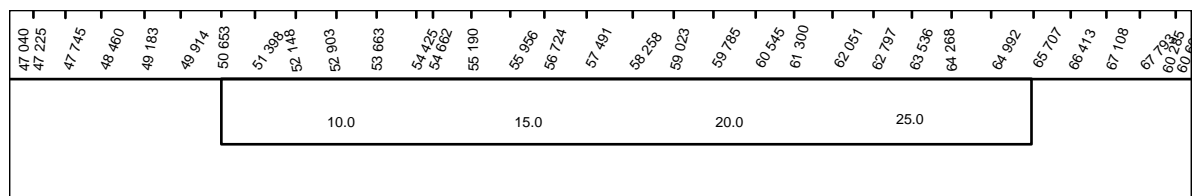
**Example 1**

In the boxes defined in the example data for option 845

846 , M001 , , BOX1 , 7=3 . 0

846 , M001 , , BOX4 , -5 , 5=250 , 7=-11 , 8=350 , 10=90 . 0

would produce the following arrangement



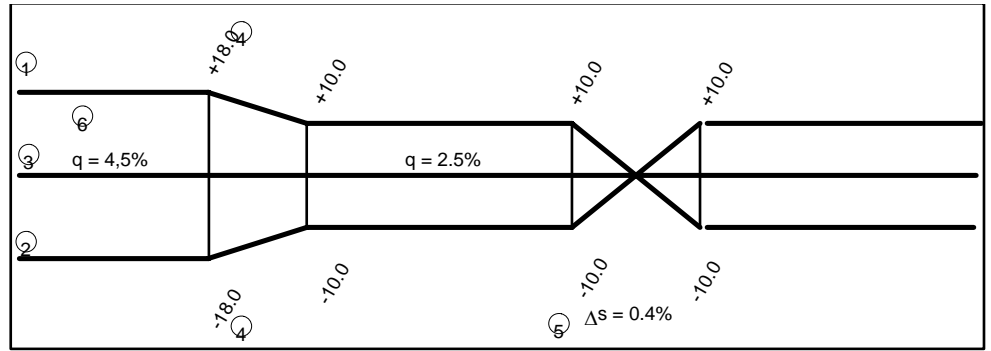
**Figure 3 - 131 Example - minor option 846**

**Example 2**

A crossfall schematic to annotate long section drawings according to German standards:

846 , SUPE , , BOXA , 7=-3 6

846 , MAST , CLEF , CRIG



Key

- 1 Right channel superelevation shown as dashed line.
- 2 Left channel superelevation shown as solid line
- 3 Zero datum shown as chain dotted line
- 4 Vertical offset drawing units for each channel (+ve above, -ve below)
- 5 Rate of change at crossover point
- 6 Percentage crossfall shown on datum (only on constant crossfall areas) annotated at element mid point

Figure 3 - 132 Crossfall schematic

Example 3

A vertical element schematic to annotate vertical elements according to Japanese standards:

846 , G001 , , BOX1 , 7 = - 35

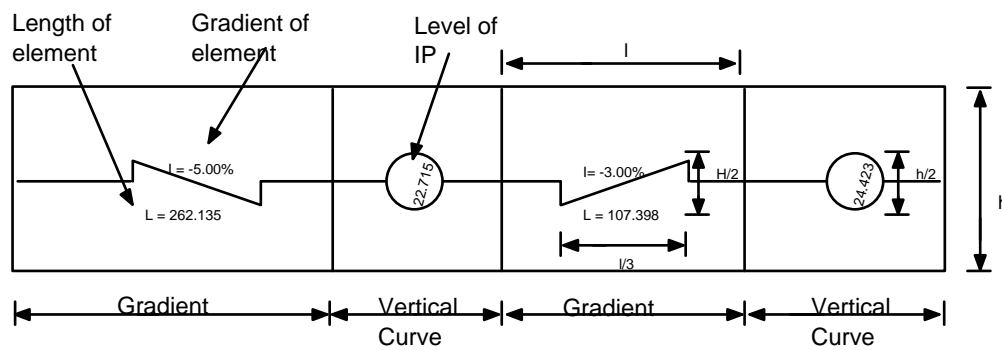


Figure 3 - 133 Vertical element schematic

Example 4

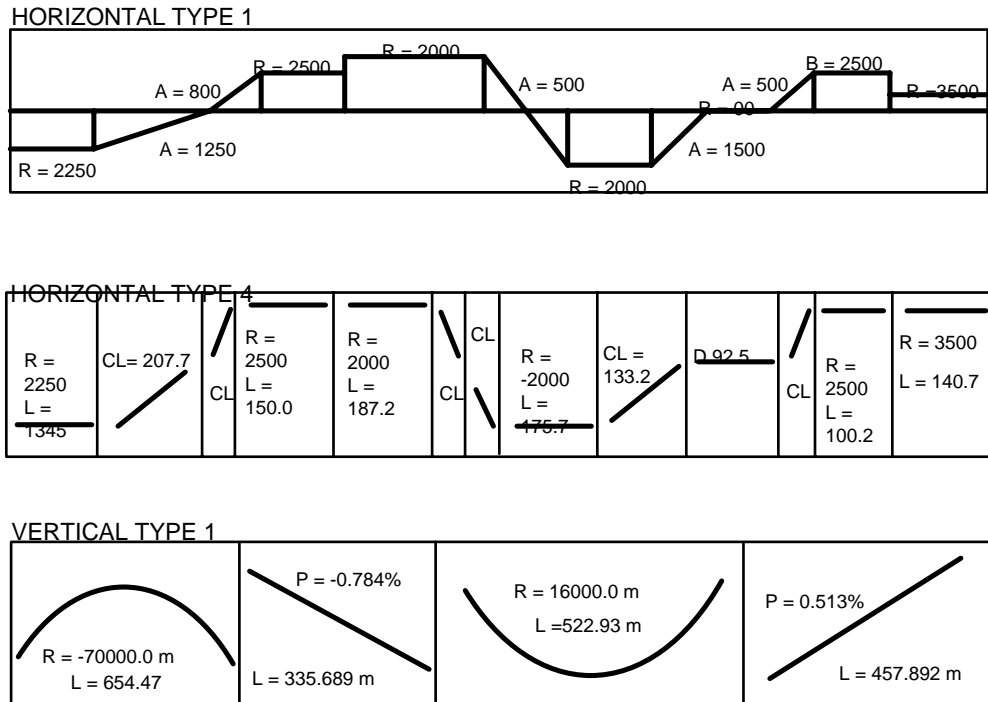


Figure 3 - 134 Examples - Geometry string additional information

Minor option 847 Draw text in a box area

Minor option 847 is used to place alphanumeric text into an annotation area previously defined on an 845 option. The current text style and colour are used.

The text may be

- a predefined word such as CHAINAGE, DISTANCE or LEVEL
- input directly using an option 001 record immediately following
- a mixture of text and text variables  
eg CHAINAGE XXXX.XX changes for each section.

Input

Linemode

Minor option 847

- \* Field 1 C use CHAINAGE
- D DISTANCE
- E EXISTING
- P PROPOSED
- L LEVEL

\* use the text that follows on an 001 option, note that this string may contain embedded text variables.

- \* Field 3 Area name, annotation is placed in this area previously defined on an 845 option.

If a text variable (see 848) has been defined only this text is to be included. It is possible to code the text variable name in field 1.

Field 10 Angle of text measured clockwise relative to the left hand side of the drawing.

If the angle is positive, text is positioned measured clockwise relative to the left hand side of the drawing. If negative, text is positioned clockwise relative to the normal lying to the left of the string.

◇ *Note that the text is first rotated, then justified.*

For variable text (ie field 1, column 1=\*) an option 001 record must immediately follow the 847 record.

**Minor option 001**

Any text is permissible except '&'.

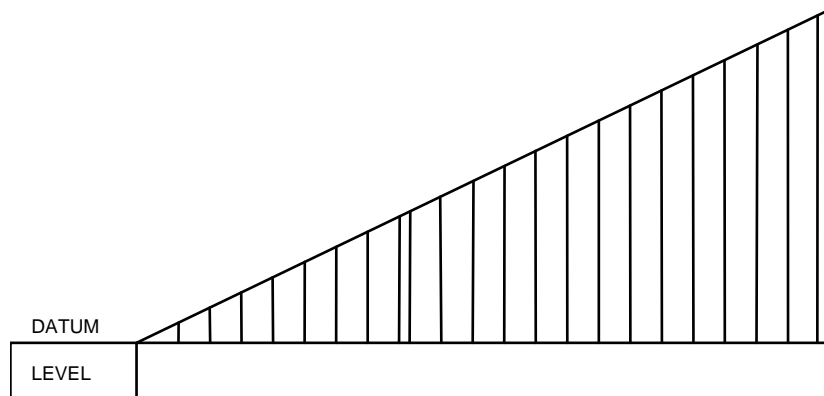
Text variables may be included (see option 848) and these are signified by enclosing within ampersands eg &VARI&.

**Example**

```

845 ,BL, BC ,BOX2 , 6=-3 , 3 , 10=1.5
845 ,BBL, CC ,BOX5 , 6=-3 , 3 , 9=-1.5 , 1.5
847 ,L, , BOX5 , 10=0.0
847 ,* , ,BOX2 , 10=0.0
001DATUM

```



**Figure 3 - 135 Example - Minor options 845, 847 and 001**

**Minor option 848 Define a text variable**

THIS OPTION MUST OCCUR BEFORE THE 847 OPTION WHICH USES IT.

A text variable contains information extracted from a string point and converted into character form. It is updated each time the system considers a new point within the string or section being drawn. In the case of level datum annotation the value is derived from all sections drawn within the particular window.

For cross sections, a positive string dimension coded in field 7 will extract information from the associated point on the reference string. Positive string dimensions cannot be used with long sections.

## Input

### Linemode

#### Minor option 848

- |           |   |
|-----------|---|
| Field 1   | Label of string, from which information is extracted (long sections only)   |
| Field 2   | Section set reference letter (cross sections only).<br>The subreference of the section string will be used to derive the associated reference string where this is needed.  |
| * Field 3 | Text variable name.   |
| Field 7   | String dimension to be output eg 3.0 would give the level, 5.0 would give the cut string label for a section string. If a negative value is coded, values can be extracted from the string index or derived values can be drawn as follows. <ul style="list-style-type: none"> <li>- 1.0 String label</li> <li>- 2.0 Subreference</li> <li>- 4.0 Number of points in string</li> <li>- 9.0 Value of the level datum of the drawn section window.</li> <li>- 11.0 Point sequence number of the reference string</li> </ul> |

For full details of DRAINAGE string dimensions see Chapter 12 Drainage.

### Example

```
845 , BBL , CC , BOX3 , 9 = - 0 . 75 , 0 . 75
848 , , R , 3 = CHAN , 7 = 4 . 0
847 , * , , BOX3 , 10 = 0 . 0
001 , CHAINAGE & CHAN &
845 , BL , CC , DATM , 6 = - 6 , 6 , 10 = 3
848 , , R , 3 = LEVL , 7 = - 9
847 , * , 3 = DATM , 10 = 0 . 0
001 , DATUM = & LEVL &
```

This will extract the chainage (dimension 4) from the section reference string, convert it to characters and place it in a text variable named CHAN. It will also derive the datum level of all sections drawn in each particular section window and place the value in a text variable named LEVL.

## Minor option 849 Draw ordinates from an axis to a string

Draw short or full ordinates from the horizontal or vertical axis to points on the string. The current linestyle will be used.

### Input

#### Linemode

#### Minor option 849

- |             |   |
|-------------|---|
| Field 1     | Label of string or section set reference letter.  |
| Field 2     | (Long sections only)<br>Label of string from which normals are erected to define extents of string to be drawn.<br>If omitted string in field 1 is assumed.   |
| Field 3     | Column 1<br>V draw vertical ordinates from the horizontal axis to the string points.<br>H draw horizontal ordinates from the vertical axis to the string points.<br><br>Column 2<br>F draw full length line.<br>S draw short ordinate from axis.<br>W draw ordinates to top of section window   |
| Field 4     | Interval for the drawing of ordinates.<br>If omitted all string points are drawn.<br>If the string is a Master Alignment, this is taken as the chainage interval, if a 3 dimensional string, interface or section the point nearest to the multiple of this distance is taken.<br>If the interval is coded as a negative number it is assumed to be a point number interval, eg - 2 means draw annotation at every second string point. A reference chainage for distance intervals may be specified on an additional 804 record. |
| Field 5 & 6 | SPRD for start point of part of string for which annotation drawn. If omitted the start of the string is assumed.   |
| Field 7     | Offset from datum for start of ordinate (drawing units).  |
| Field 8 & 9 | SPRD for end point of part of string for which annotation is drawn. If omitted, the end of the string is assumed.   |
| Field 10    | Length of short ordinate. If omitted default tick size is used.   |
- ◇ *The geometry string code used to indicate the points to which ordinates are drawn should be specified using minor option 809, 'Geometry string annotation'.*

Example

```
849,M001,,VF  
849,M001,,HS
```

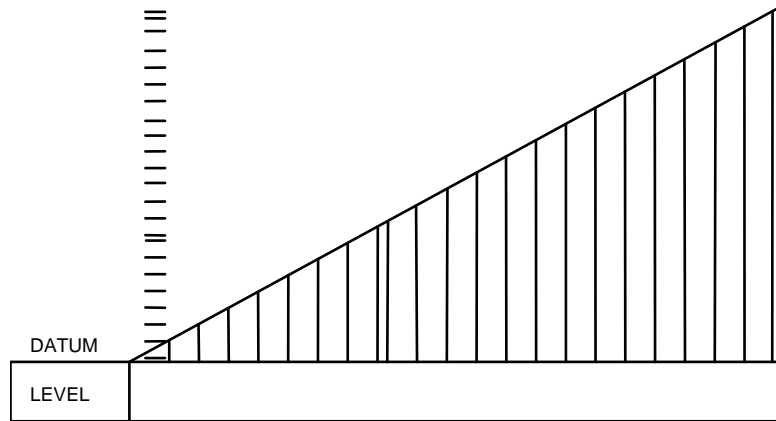


Figure 3 - 136 Example - Minor option 849

**Minor option 853 - 869 Point related annotation**

This section describes the various types of annotation which may be derived from string data and may be drawn at string points. The strings themselves may or may not have been drawn with minor options in the range 825-840. The annotation options 853-869 may be used singly or in combination to build the most complex patterns of annotation.

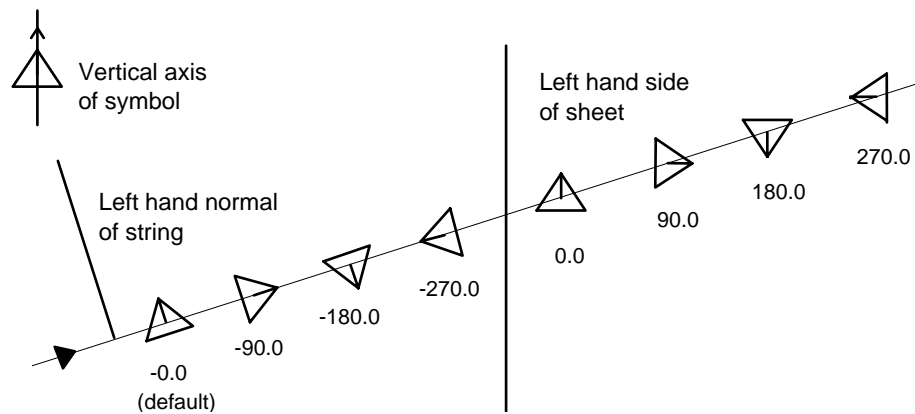
The options available fall into the following groups:

853	Annotate crossfall
854	Annotate gradient symbol
856	Draw cadastral symbols
857	Annotate points with text
858, 864	Annotate between points
859	Annotate at points
860, 861, 862, 863,	Annotate points with symbols
865, 866, 867, 868, 869	Annotate points with information

**Angles of symbol and text**

The angles of symbol and text (in plan) adopt the following conventions:

- They are always related to the vertical axis through the symbol or piece of text.
- A negative angle is measured from the left hand normal of a string.
- A positive angle is measured from the left hand edge of the drawing sheet.



**Figure 3 - 137 Angle of symbol**



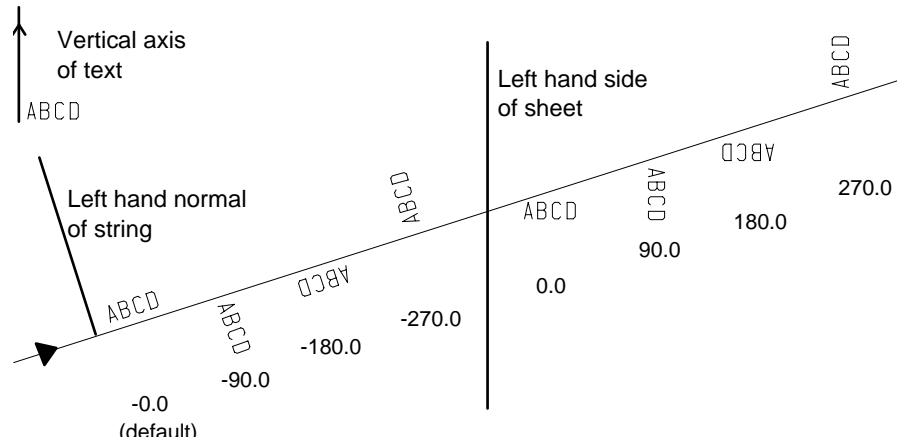


Figure 3 - 138 Angle of text

Users should be aware that options 854, 865, 866 and 867 are specialist options which do not allow the orientation to change and are not affected by this convention.

### Text offset

Text offset is used in many annotation options to position text at an offset from a string. Text increment may then be applied to move the text along its vertical axis, allowing blocks of text to be drawn at the same text offset.

Text offset adopts the following conventions:

- For annotation between points, the offset is applied in the same direction as the vertical axis of text.
- For annotation at points, the offset is applied in the same direction as the text is drawn.
- Text offset is measured between the string and the lower left corner of the box surrounding the text.
- Negative text offsets may be specified.
- Text increment is always added or subtracted in the direction of the vertical axis of text.

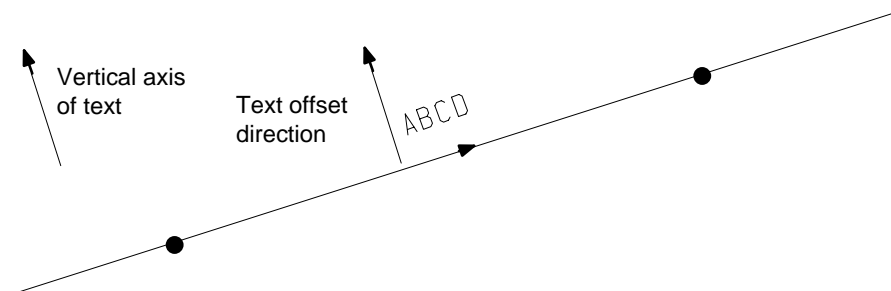


Figure 3 - 139 Text offset - between points

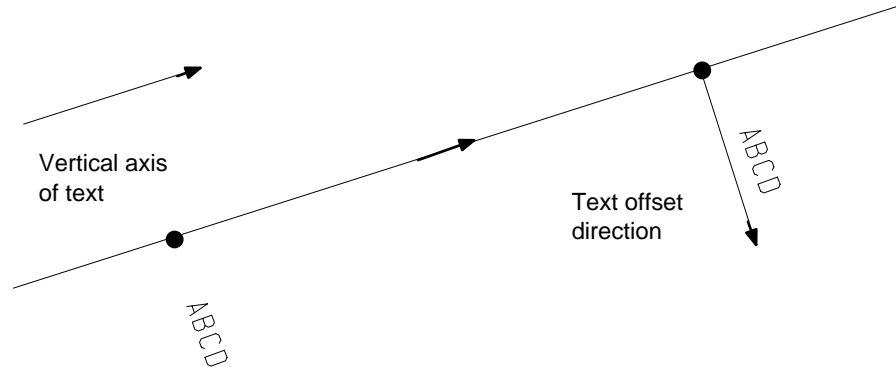


Figure 3 - 140 Text offset - at points

**Text increment**

Text increment is used to draw blocks of text at a specified text offset. By using text increment, line spacing is calculated automatically so that text is evenly spaced in the block.

Several minor options make use of text increment. It is specified using an indicator as follows:

- Imnn            Increment text by 'nn' lines in the direction of the vertical axis of text.  
                   If 'm' is 0, align text along its bottom edge.  
                   If 'm' is C, align text along its centre line.
- Dmnn            Decrement text by 'nn' lines in the reverse direction of the vertical axis of text.  
                   If 'm' is 0, align text along its bottom edge.  
                   If 'm' is C, align text along its centre line.

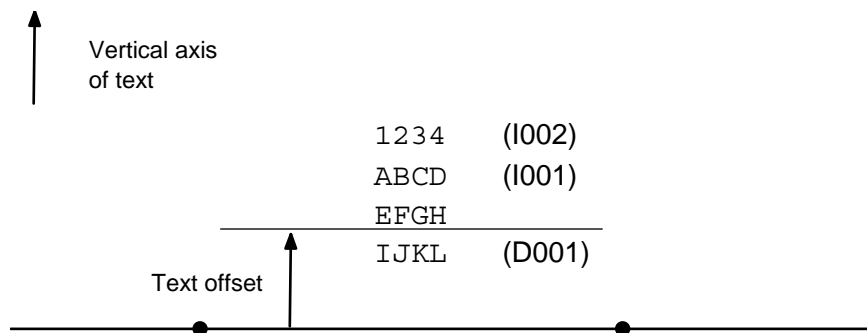


Figure 3 - 141 Text increment - between points

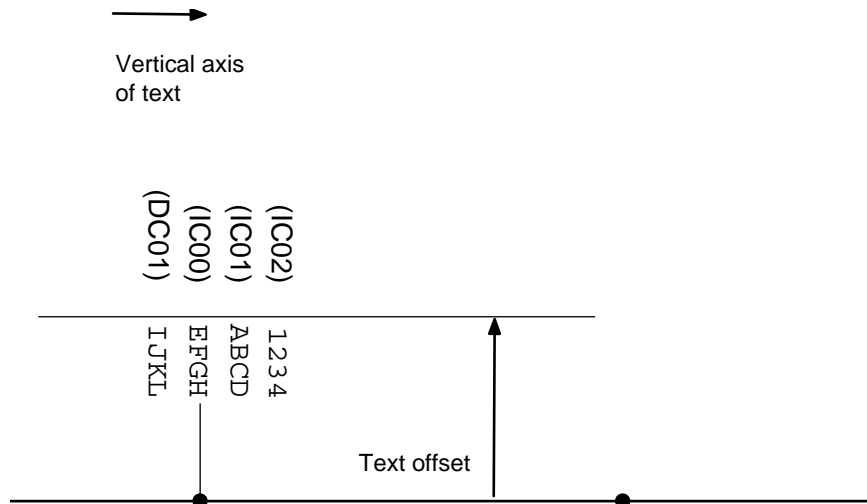


Figure 3 - 142 Text increment - at points

## Minor option 853 Annotate crossfall

Annotate crossfall with wedge symbol and value on plan.

### Input

#### Linemode

#### Minor option 853

Field 1 Reference string label; note that the string itself is not drawn, only the annotation.

The reference string specified must be a master string.

Field 2 First subsidiary string label

Field 3 Second subsidiary string label

Field 4 Interval at which string is to be annotated:

If blank, annotate points at which a change in crossfall occurs

If positive, annotate at the specified interval

If negative, annotate at every specified number of points

Fields 5 & 6 SPRD for first point

Fields 8 & 9 SPRD for last point

◇ *Points of zero crossfall are represented by a line drawn between the subsidiary strings.*

◇ *Where two crossfall values are shown, the top value represents the left hand crossfall and the bottom value represents the right hand crossfall relative to the reference string.*



Figure 3 - 143 Crossfall annotation at points of change

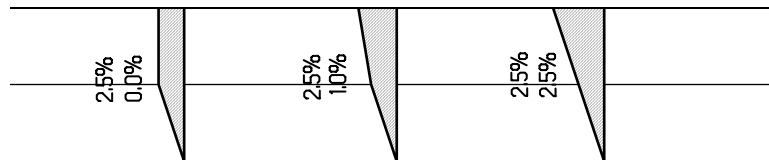


Figure 3 - 144 Crossfall annotation at a given interval

### Examples

```

ANNOTATE ALL CHANGES IN CROSSFALL
853,M001,CR01,CL01
    
```

```

ANNOTATE AT A 50M INTERVAL
853,M001,CR01,CL01,50
    
```

```

ANNOTATE EVERY TENTH POINT
853,M001,CR01,CL01,-10
    
```

## Minor option 854 Annotate vertical intersection points

### Draw gradient symbol

Annotate with a vertical intersection point (VIP) symbol indicating the gradient at vertical intersection points. The annotation may be drawn in plan or on a long section.

To annotate the symbol itself, specify another 854 record and code the fields as described in the following section, 'Annotate gradient symbol'.

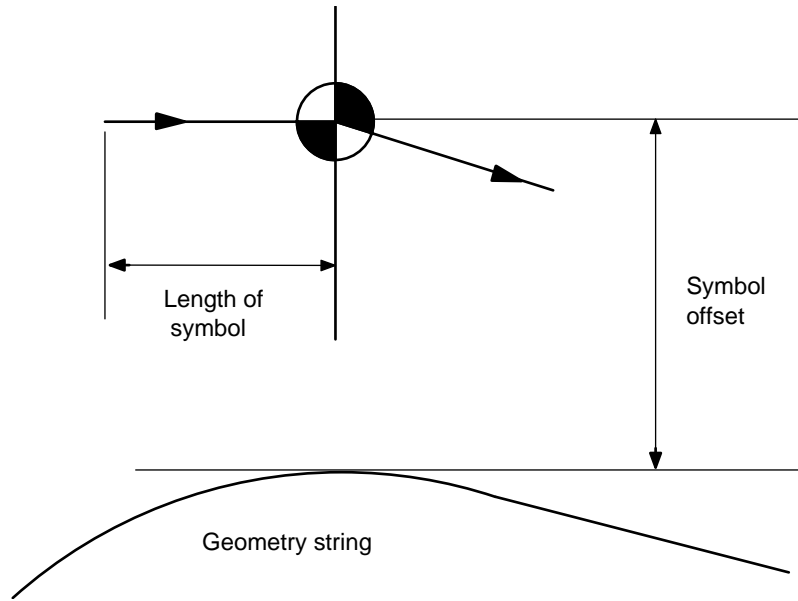


Figure 3 - 145 Gradient symbol

**Input**

Linemode

**Draw gradient symbol**

Minor option 854

Field 1 Label of geometry string

Field 3 Symbol switch:

Plan drawings:

0 Whole symbol (default)

1 Gradient legs and arrow only

2 VIP symbol only

3 Gradient legs, arrow and VIP symbol

Long section drawings:

10 VIP symbol, gradient links and bottom legs (long sections only)

Field 4 Length of symbol

Fields 5 & 6 SPRD for start

Field 7 Symbol offset

Symbol offsets should be coded positive for the outside of a curve and negative for the inside.

The default symbol offset is determined by the variable DSPOTLEV in the parameter file.

Fields 8 & 9 SPRD for end

- ◇ *The shading used within the symbol is determined by minor option 807 'Fill area characteristics'.*
- ◇ *The bottom leg of the symbol is drawn normal to the string in plan drawings, and normal to the sheet in long section drawings.*

## Annotate gradient symbol

Annotate gradient symbols with the value taken from a string point dimension.

The gradient symbols must have been drawn using a previous 854 record, 'Draw gradient symbol'.

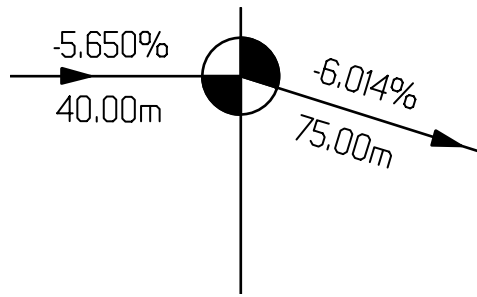


Figure 3 - 146 Gradient symbol annotation

### Input

#### Linemode

#### Annotate gradient symbol

First record:

#### Minor option 854

Field 1 Label of geometry string; note that the string itself is not drawn, only the annotation.

Field 2 Text increment (Imnn / Dmnn)

Field 3 Symbol switch:  
4 Text

Field 4 Length of symbol

Field 5 & 6 SPRD for start of annotation.

Field 7 Symbol offset

Field 8 & 9 SPRD for end of annotation.

Field 10 Gradient switch (only used if the subsequent 854 option has Field 4 set to -23):

- 1 Percent gradient (default as per setting in parameter file)
  - 2 Per mille gradient
- The default gradient switch setting is determined by the variable DGRADTYP in the parameter file.

Second record:

Minor option 854

Field 3 Text variable name

Field 4 String dimension to be used.

-21.0 Partial distance between adjacent points

-23.0 Gradient between adjacent points

◇ *The second record must be followed by an 001 record specifying the text to be used.*

Minor option 001

Any text is permissible.

◇ *If a percent character is used and permille interpretation is requested, a permille symbol is drawn instead.*

Example 1

```

DRAW GRADIENT SYMBOLS AT VERTICAL INTERSECTION
POINTS AND ANNOTATE WITH GRADIENT AND PARTIAL
DISTANCE
DRAW, DESIGN MODEL
VERTICAL ANNOTATION SYMBOLS
809, VIPS
854, G001, , , 4, 7=10
VERTICAL ANNOTATION - GRADIENT TEXT
854, G001, , 4, 4, 7=10
854, 3=VAR1, -23
001, &VAR1&%

VERTICAL ANNOTATION - PARTIAL DISTANCE TEXT
854, G001, D001, 4, 4, 7=10
854, 3=VAR2, -21
001, &VAR2&m

999

```

Example 2

This example annotates a geometry string in a long section drawing between chainages 240 and 520. The gradient is output in permille format to four decimal places.

The % character on the 001 record is replaced by a permille symbol on the drawing.

```

DRAW, LONG SECTION MODEL
...
809, VIPS
    DRAW VIP SYMBOLS, GRADIENT LINKS AND BOTTOM LEGS
854, GRIP, , 10, 7.5, 240, 7=7.5, 8=520
    ANNOTATE WITH GRADIENT
854, GRIP, , 4, 7.5, 240, 7=7.5, 8=520, 10=2
854, 3=VAR1, -23
001, Gradient=&VAR1&%
...
999
    
```

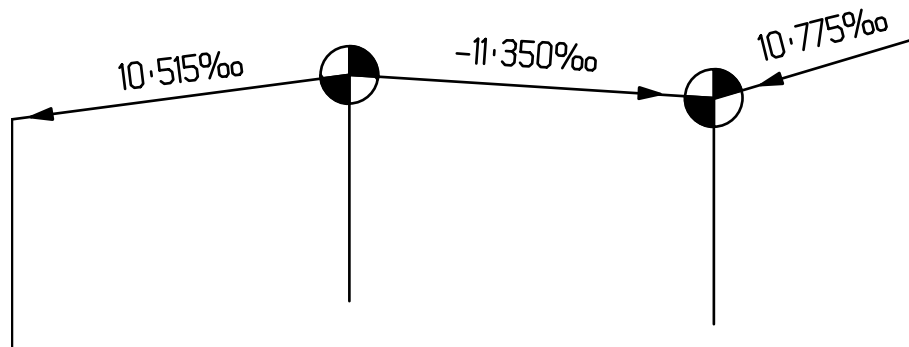


Figure 3 - 147 Long section annotated with VIP symbol

## Draw vertical curve details

Draw details of vertical curves at the vertical intersection points on a profile. The annotation is drawn above or below the profile, depending upon the space available (see Figure 3 - 148). The following information is shown:

- Vertical tangent points (indicated by an ordinate and marked with chainage).
- Vertical mid points (indicated by an ordinate and marked with chainage).
- Mid ordinate distances.
- Vertical curve length.



**Input**

## Linemode

**Draw vertical curve details**Minor option [854](#)

Field 1      Label of geometry string

Field 3      Symbol switch:

5            Vertical curve details

Fields 5 &amp; 6   SPRD for start of annotation

Fields 8 &amp; 9   SPRD for end of annotation

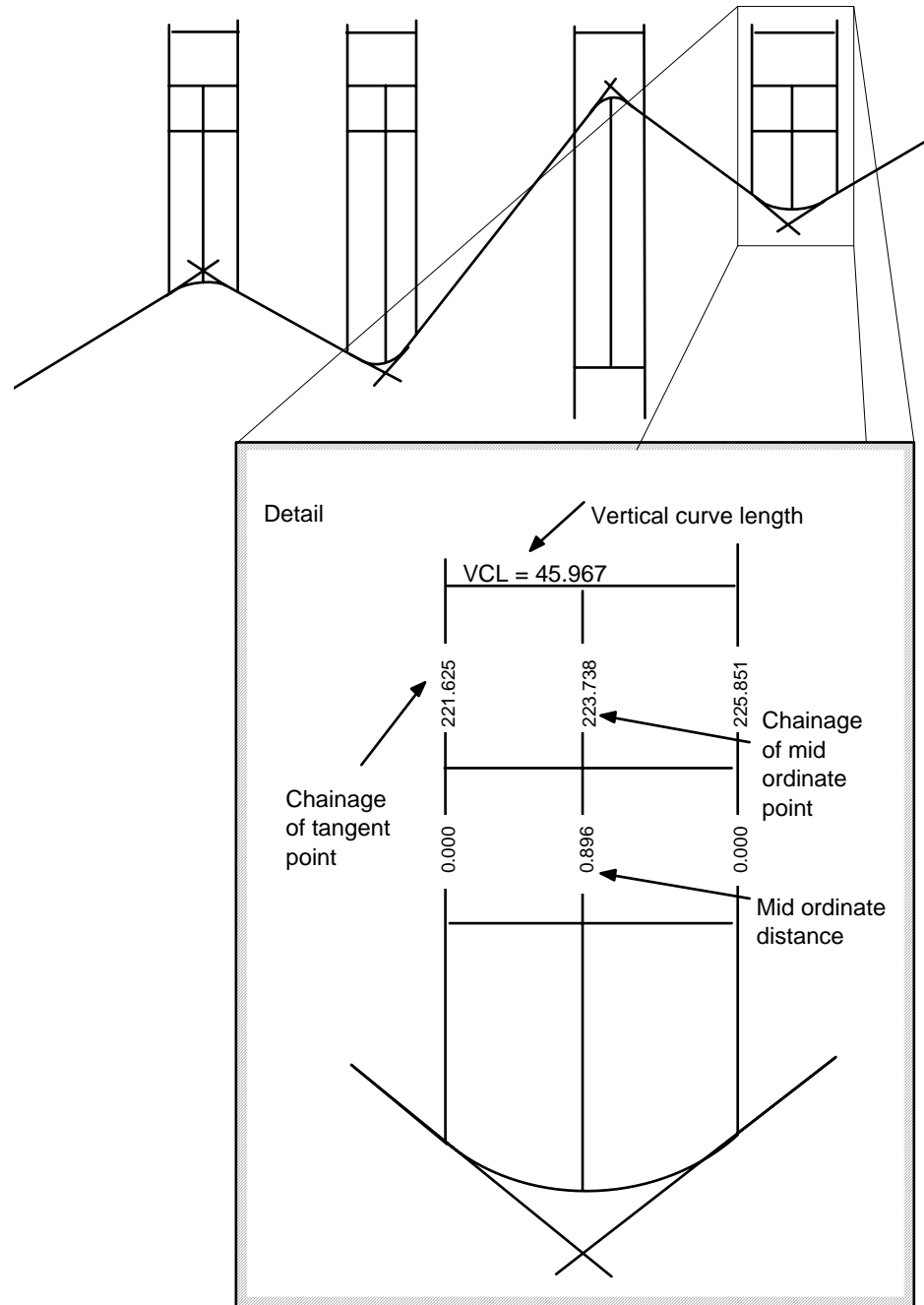


Figure 3 - 148 Vertical curve details

### Minor option 856 Draw cadastral symbols

This option draws a cadastral symbol at specified points on a cadastre string.

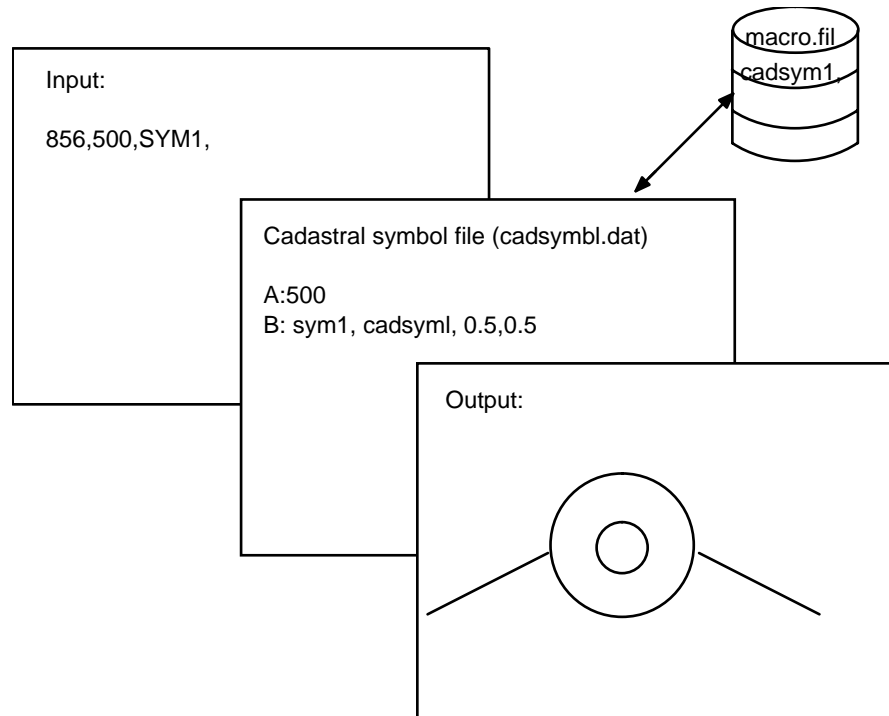
#### Cadastre strings

A cadastre string is a ten-dimensional string which uses macrosymbols to represent different land boundaries or ownership on a drawing.

**Drawing cadastre strings**

Cadastre strings can be drawn only in plan as symbols, with or without associated line work. The symbols drawn at each point are controlled by a point feature code which acts as an index to an entry in the cadastral symbol file (cadsymb1.dat).

The cadastral symbol file comprises several tables; each table in the file has its own name and contains the information required to select and size a macrosymbol and draw it at any point on the cadastre string.



**Figure 3 - 149 Accessing the cadastral symbol file**

Cadastral symbols can be invoked in DRAW simply by specifying the name of the table in minor option 856.

Rotation of symbols can be uniquely varied for each symbol with respect to the rotation reference. The rotation reference applies to all the points on the string and is defined by the string subreference. The rotation reference can be either:

- SHEET the left hand edge of the sheet
- NORTH true North

The rotation of each symbol is controlled by the symbol reference bearing (stored as dimension 4 with the cadastre string).

If line work is required it can be added by options 825 or 826 with the line style defined by minor option 810.

**Cadastral symbol file**

This file controls the relationship between cadastre string point data and its symbolic representation. It is a permanent file named cadsymb1.dat (with

copies stored both in the user directory and in a central directory). The copy of `cadsymb1.dat` in the user directory may be customised by the user by editing the file.

The file contains three types of record:

- Table name
- Feature code interpretation and size
- Terminator record

The file structure is as follows:

```
A:Table name 1
B: feature code,macrosymbol name,symbol width,symbol
height
B:
B:
A:Table name 2
B: feature code,macrosymbol name,symbol width,symbol
height
B:
B:
```

END

### Example

```
A:500
B: TREE,TREESYMB,0.8,0.8
B: CAVE,CAVESYMB,1.0,1.0
B: MANH,ROMHNOID,0.6,0.6
B: SEAT,SEAYSYMB,1.2,0.3
A:1250
B: TREE,TREESYMB,0.8,0.8
B: CAVE,CAVESYMB,0.4,0.4
B: MANH,ROMHNOID,0.25,0.25
B: SEAT,SEAYSYMB,0.1,0.12
.
.
.
END
```

- ◇ *The cadastral symbol file can be created and edited using a standard editor.*
- ◇ *A maximum of 100 feature code interpretations (B: lines) may be stored in each block entry.*

### Cadastral annotation

Each cadastre point has a maximum of ten dimensions which you may wish to add to a drawing as annotation. Minor options 859 and 869 allow you to do this.

**Preparing a drawing with cadastre strings**

To prepare a drawing with cadastral symbols the following steps are required:

1. Create all macrosymbols to be used in the cadastre strings. Ensure that all macrosymbols are set up as impermeable so that major option CLIP can be used to remove underlying information.
2. Set up the cadastre symbol file to relate feature codes to sized macrosymbols.
3. Use major option EDIT to add feature code and symbol reference bearing (rotation) information for each cadastre point of the cadastre string.
4. Draw cadastral symbols using DRAW minor option 856.
5. Add line work to the drawing using DRAW minor options 825 and/or 826. By default, this line work will be drawn erasable and so will be subject to clipping.
6. Add drawing details using DRAW minor options 859 and 869. Set up the clipping environment using minor options 818 and 819 so that any annotation you add is permanent and will form a clip polygon.
7. Use major option CLIP to create the final drawing. This will remove underlying information from both cadastral symbols and annotation.

**Input**

**Graphics**

**IGDRAWT.DAT, DRW006, DRW054**

Add drawing details	Draw cadastral symbols
Annotation	Cadastral string label/mask
<b>Draw cadastral symbols</b>	Interpretation table name
Hatching	Feature code
Grids/Frames	Start point no.
Text strings	End point no.
Draw selected strings	
Draw null/zero levels	
Draw contour strings	
Triangulation options	
Draw drainage network	

**Linemode**

**Minor option 856**

Field 1 Cadastre string label. The string label must begin with 'P'.

	A partial string label may be specified.
Field 2	Table name. The table name must match an 'A:' record in the cadastral symbol file.
Field 3	Feature code. A partial feature code may be specified. If blank, the symbols for all codes are drawn. The feature code must match a 'B:' record in the cadastral symbol file.
Field 6	Start point number.
Field 9	End point number.

## Minor option 857    **Annotate points with text**

Minor option 857 is only valid for long sections, it will draw text on profiles at points of intersection. The current text style and colour are used.

Minor option 857 searches a long section string (dimension 5) for the label of the intersecting string matching that coded in field 2, and annotates the points found using text extracted from a following 001 record.

Text may be placed into an annotation area previously defined on an 845 option (code box name in field 3,) or drawn at string points similar to an 869 option (field 3 blank, field 7 offset can be coded).

### Input

#### Linemode

#### Minor option 857

Field 1	Label of string; note that the string itself is not drawn, only the annotation.
Field 2	Label of intersecting string (partial masks may be used).
* Field 3	Area name, annotation is placed in this area previously defined on an 845 option.
Field 5 & 6	SPRD for start of string to be drawn, if omitted the start of the string is assumed.
Field 7	Text offset, measured from string to start of text in current linear measure units (blank if field 3 is coded).
Field 8 & 9	SPRD for end of string to be drawn, if omitted the end of the string is assumed.
Field 10	Angle of text. If the angle is positive, text is positioned measured clockwise relative to the left hand side of the drawing. If negative, text is positioned clockwise relative to the normal lying to the left of the string.

Minor option 001

Any text is permissible. Text variables may not be used.

### Minor option 858 and 859 Adding string and point information

These options allow the user to annotate along strings and at points with information stored within the string using text variables. This is particularly useful for annotating geometry information in plan and profile and annotating drainage networks.

Pipes and manholes may need to be annotated with information stored within their strings. For example length, level, gradient, and constructions details are essential parts of a drainage drawing.

Both minor options allow the use of multiple text variables. The options generating the variables can be stacked with a subsequent 001 option to use them and define the sequence of presentation.

### Minor option 858 Information along a string

Minor option 858 provides the facilities required to annotate text along a string. Facilities include:

- Including dimensions as a text variable within annotation
- Text justification and offset.

#### Input

#### Graphics

IGDRAWT.DAT, DRW018, DRW046, DRW047

Annotator	Information along a string	Information along a string
Information along a string	String label	Variable
Information at point:	Text	String dimension
Pips	Innn/Dnnn	
Macrosymbols at string pt	Text offset (+/-)	
Scaled macrosymbols at pt	Start chainage / X coord	
Standard symbols at a p	Start point no. / Y coord	
Between string point:	End chainage / X coord	
Point sequence number:	End point no. / Y coord	
Chainages on 1 side only:		
Chainages on both side:		

◇ *The third menu containing 'text variable' information will only be displayed if a 'text variable' in the form &PIPE& is included in the second menu Text.*



Linemode

**First record**

Minor option 858

- Field 1 String label
- Field 2 Text increment (Imnn / Dmnn)
- Fields 5 & 6 SPRD of start
- Field 7 Text offset, measured from string to start of text in current linear measure units.
- Fields 8 & 9 SPRD of end

**Subsequent records**

Minor option 858

- Field 3 Text variable name
- Field 4 Dimension to be drawn

The following values are used for geometry strings with the information code HTPS only:

- 1.0 String label
- 2.0 Subreference
- 3.0 String contents indicator
- 4.0 Number of points in string
- 5.0 Minimum x coordinate in string
- 6.0 Minimum y coordinate in string
- 7.0 Maximum x coordinate in string
- 8.0 Maximum y coordinate in string
- Note that the same values would be drawn at every string point
- 11.0 Point sequence number
- 21.0 Distance between adjacent points.
- 22.0 Cumulative distance between adjacent points (long sections only)
- 23.0 Percentage gradient between adjacent points
- 24.0 Level difference between adjacent points
- 40.0 Length of straight elements
- 41.0 Bearing of straight elements
- 42.0 RL value or A value of transition elements
- 43.0 Length of transition elements
- 44.0 Radius of curve elements
- 45.0 Length of curve elements

For full details of drainage string dimensions see Chapter 12 Drainage.

- ◇ *The geometry string code used to indicate the position of the annotation should be specified using minor option 809, 'Geometry string annotation'.*

- ◇ For geometry strings, the offset should be specified using minor option 809, 'Geometry string annotation'.

Examples

Pipe information annotation

```
858,S010,7=1.0
858,3=PTYP,22
858,3=BTYP,24
001,Pipe type=&PTYP&,Bed type=&BTYP&
will produce the following annotation:
```

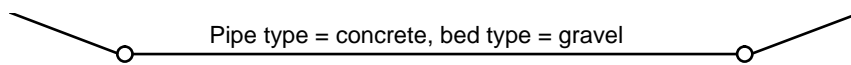


Figure 3 - 150 Example - Information along a string

Text annotation

```
809,HTPS
858,GAST,5=100
858,3=ELE1,4=-40.0
001,Gerade lg= &ELE1&m
858,GAST,7=-2.0
858,3=ELE2,4=-44.0
001,Bogen ra= &ELE2&m
```

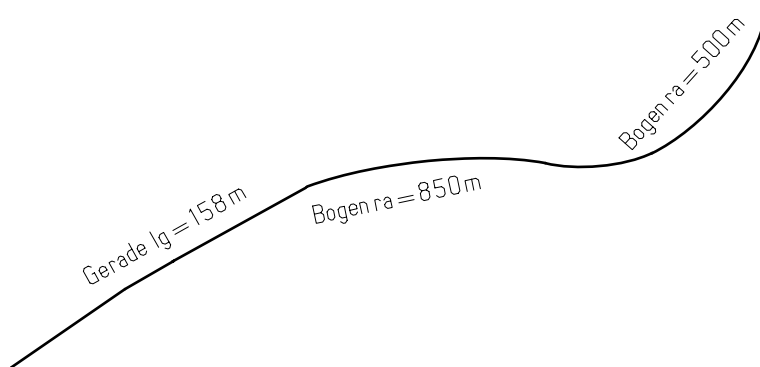


Figure 3 - 151 Lengths of straight and curved elements

```
809,HTPS
869,GAST,4=-46,5=100,8=1300
860,GAST,4=2
858,GAST,5=500,8=633.5
858,3=TRAN,-43.0
001,Übergangsbogen lu= &TRAN& m
```

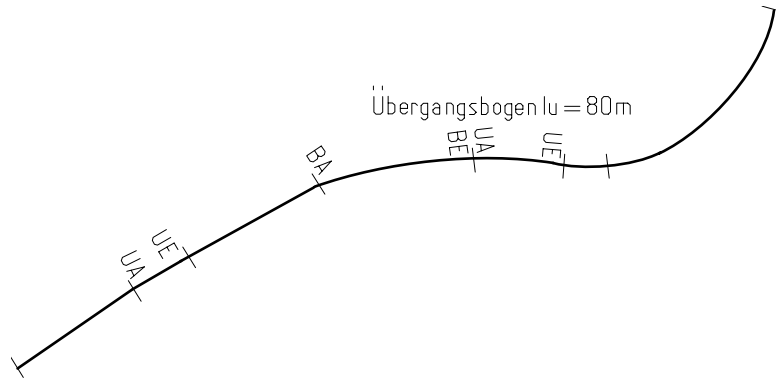


Figure 3 - 152 Length of transitions

### Minor option 859 Information at points

Minor option 859 provides the facilities required to annotate text at string points. Facilities include:

- Including dimensions as a text variable within annotation
- Including cadastre string dimensions
- Text offset and orientation.

#### Input

#### Graphics

IGDRAWT.DAT, DRW018, DRW048, DRW049

Annotation	Information at points	Information at points
Information along a string	String label	Variable
Information at points	Text	String dimension
Pips	Innn/Dnnn	
Macrosymbols at string pts	Text offset (+/-)	
Scaled macrosymbols at pts	Angle of text	
Standard symbols at a pt	Start chainage / X coord	
Between string points	Start point no. / Y coord	
Point sequence numbers	End chainage / X coord	
Chainages on 1 side only	End point no. / Y coord	
Chainages on both sides	Pipe string label	

◇ The third menu containing 'text variable' information will only be displayed if a 'text variable' in the form &PIPE& is included in the second menu Text.

Linemode

This option is used in different ways when used with any, drainage or cadastre string types.

**Any string**

**First record**

Minor option 859

- Field 1       String label
- Field 2       Text increment (Imnn / Dmnn)
- Fields 5&6    SPRD of start
- Field 7       Text offset, measured from string to start of text in current linear measure units.
- Fields 8&9    SPRD of end
- Field 10      Angle of text.

If the angle is positive, text is positioned measured clockwise relative to the left hand side of the drawing. If negative, text is positioned clockwise relative to the normal lying to the left of the string.

**Subsequent records**

Minor option 859

- Field 3       Text variable name
  - Field 4       Dimension to be drawn
    - 1.0       String label
    - 2.0       Subreference
    - 3.0       String contents indicator
    - 4.0       Number of points in string
    - 5.0       Minimum x coordinate in string
    - 6.0       Minimum y coordinate in string
    - 7.0       Maximum x coordinate in string
    - 8.0       Maximum y coordinate in string
- Note that the same values would be drawn at every string point
- 21.0       Distance between adjacent points.
  - 22.0       Cumulative distance between adjacent points (long sections only)
  - 23.0       Percentage gradient between adjacent points
  - 24.0       Level difference between adjacent points
- The remaining dimensions are valid for geometry strings only:
- 50.0       Preceding vertical tangent length (long sections only)
  - 51.0       Following vertical tangent length (long sections only)

-52.0	Vertical IP to alignment distances (long sections only)
-53.0	Vertical radii
-54.0	Vertical 'm' value
-70.0	HIP X coordinate
-71.0	HIP Y coordinate
-72.0	HIP level
-73.0	HIP chainage
-74.0	HIP tangent length
-75.0	HIP length of whole curve (curve and transitions)
-76.0	HIP deflection angle
-77.0	HIP whole circle bearing
-78.0	HIP long chord
-79.0	HIP curve to chord distance
-80.0	HIP semi-deflection angle (deflection angle / 2)
-81.0	HIP to curve length

◇ *For geometry strings, the offset should be specified using minor option 809, 'Geometry string annotation'.*

### Drainage strings

#### First record

##### Minor option 859

Field 1	String label
Field 2	Text increment (Imnn / Dmnn)
Field 3	Reference string or pipe label, if field 1 is PMAN
Fields 5&6	SPRD of start
Field 7	Text offset, measured from string to start of text in current linear measure units.
Fields 8&9	SPRD of end
Field 10	Angle of text.

If the angle is positive, text is positioned measured clockwise relative to the left hand side of the drawing. If negative, text is positioned clockwise relative to the normal lying to the left of the string.

#### Subsequent records

##### Minor option 859

Field 3	Text variable name
Field 4	Dimension to be drawn
-1.0	String label
-2.0	Subreference

- 3.0 String contents indicator
- 4.0 Number of points in string
- 5.0 Minimum x coordinate in string
- 6.0 Minimum y coordinate in string
- 7.0 Maximum x coordinate in string
- 8.0 Maximum y coordinate in string

Note that the same values would be drawn at every string point

When using dimensions -21 to -24, M should be coded in column 2, field 2 of the 845 option.

- 21.0 Distance between adjacent points.
- 22.0 Cumulative distance between adjacent points (long sections only)
- 23.0 Percentage gradient between adjacent points
- 24.0 Level difference between adjacent points

For full details of drainage string dimensions see Chapter 12 Drainage.

**Cadastre strings**

**First record**

**Minor option 859**

- \* Field 1 Cadastre string label/partial label
- \* Field 2 Text increment (Imnn/Dmnn)
- \* Field 3 Feature code
- Field 6 Start point number
- Field 7 Text offset, measured from string to start of text in current linear measure units.
- Field 9 End point number
- Field 10 Angle of text

If the angle is positive, text is positioned measured clockwise relative to the left hand side of the drawing. If negative, text is positioned clockwise relative to the normal lying to the left of the string.

**Subsequent records**

**Minor option 859**

- Field 3 Text variable name
- Field 4 Dimension to be drawn
  - 1 X coordinate
  - 2 Y coordinate
  - 3 Z coordinate
  - 4 Symbol reference bearing
  - 5 Survey point number
  - 6 Point feature code

7 Cadastre point number

Example 1

**Any string**

Chainage and level annotation

```

859,mast,10=-90
859,3=levl,3
001,level = &levl&
859,mast,7=-3.5,10=-90
859,3=chan,4
001,chainage = &chan&

```

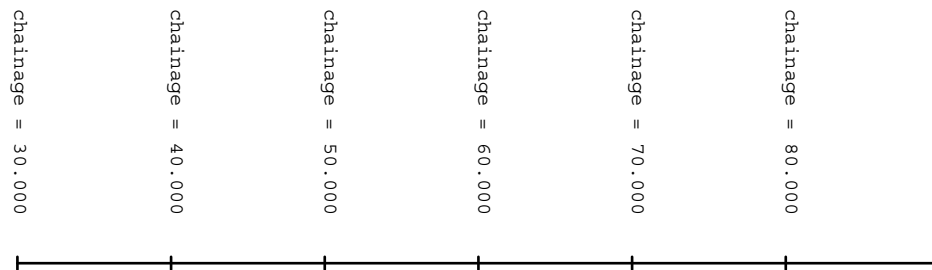


Figure 3 - 153 Information at points (any string)

Example 2

**Drainage string**

Manhole information annotation

```

859,PMAN,I001,S001,7=1.0
859,3=NUM1,5
001,Manhole number &NUM1&
859,PMAN,I002,S001,7=1.0
859,3=COVL,3
001,Cover level &COVL&

```

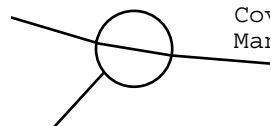


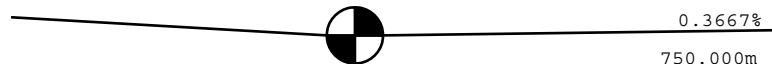
Figure 3 - 154 Example - Information at points (drainage string)

Example 3

**Geometry string**

```
859,GAST,I001,7=-2
859,3=CHAN,4
001,km=&CHAN&
859,GAST,I002,,7=-2
859,3=LEVL,3
001,nn=&LEVL&
859,GAST,I003,,7=-2
859,3=VERA,-54
001,h=&VERA&
859,GAST,I004,,7=-2
859,3=TANG,-50
001,t=&TANG&
859,GAST,I005,,7=-2
859,3=FDIS,-52
001,f=&FDIS&
```

```
km = 1400.000
nn = 132.340
h = -10000.000
t = 66.083
f = -0.218
```



**Figure 3 - 155 Information at points (geometry string)**

Example 4

**Cadastre string**

```
859,p001,i002,7=0,,2,0
859,3=spnt,4=5
001,Survey pnt no. &spnt&
859,p001,i001,7=0,,2,0
859,3=desc,4=7
001,Description &desc&
```



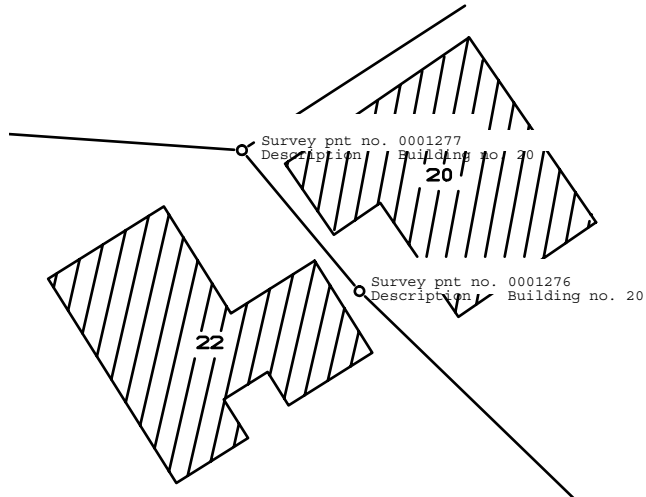


Figure 3 - 156 Information at points (cadastre string)

Example 5

**HIP annotation**

```

moos
newdpf, designdpf
draw, designmodel
800,4=1,5=3
802,4=0.5
803,plan,nopa,7=500,5=4092,6=8575,4=357
805,green
806,green
019,mast,4=-1
019,gast,4=-1
826
805
806

    // DRAW VIP SYMBOLS AT HIPS
809,hips
818
826,gast
818,perm
819,poly
861,gast,vipsymb1,4=0.3
808,4=0.25

    // DRAW HIP IP02 TEXT WITH ALL -70 annotation
859,gast,d003,7=0.4,10=0,6=2,9=2
859,3=hips,-11
001,IP. &hips&
859,gast,d004,7=-0.2,10=0,6=2,9=2
859,3=hipx,-70
001,X=&hipx&
    
```

```

859,gast,d005,7=-0.2,10=0,6=2,9=2
859,3=hipy,-71
001,Y=&hipy&
859,gast,d006,7=-0.1,10=0,6=2,9=2
859,3=hial,-76
001,IA=&hial&
859,gast,d007,7=-0.2,10=0,6=2,9=2
859,3=hrad,6
001,R=&hrad&
859,gast,d008,7=-0.1,10=0,6=2,9=2
859,3=htln,-74
001,TL=&htln&
859,gast,d009,7=-0.1,10=0,6=2,9=2
859,3=hcln,-75
001,CL=&hcln&
859,gast,d010,7=0,10=0,6=2,9=2
859,3=hsll,-79
001,SL=&hsll&

```

ENHANCE DRAW CIRCLE

enhance

```
889,circ,5=8.5,3.2,2
```

999

clip

finish

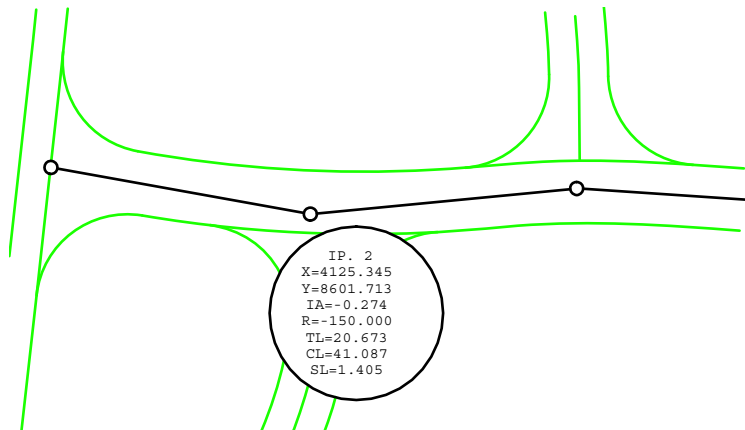


Figure 3 - 157 HIP annotation

Minor option 860, 861, 862, and 863 Symbol annotation

The symbols may be:

- 860 Pip marks, being short lines drawn normal to the string.
- 861 Macrosymbols, previously defined, and recalled from the macrofile.
- 862 Macrosymbols scaled according to a string dimension eg a circle symbol scaled according to population density.
- 863 Installation dependent or device dependent standard symbol

◇ *Macrosymbols should not be confused with macrolines and standard symbols: Macrolines are drawn between two or more points, macrosymbols and standard symbols are located at individual points. The appearance of a macrosymbol is defined by major option MACRO, whereas the appearance of standard symbols is fixed.*

Minor option 860 Pips

Input

Graphics

IGDRAWT.DAT, DRW018, DRW019

Annotation	Pips
Information along a string	String label
Information at points	Pip length
Pips	Start chainage / X coord
Macrosymbols at string pts	Start point no. / Y coord
Scaled macrosymbols at pts	Pip offset
Standard symbols at a pt	End chainage / X coord
Between string points	End point no. / Y coord
Point sequence numbers	Angle of symbol
Chainages on 1 side only	
Chainages on both sides	

Linemode

Minor option 860

- Field 1 Label of string; note that the string itself is not drawn, only the annotation.  
Mask; all strings satisfying this mask will be drawn.

If all strings satisfying the current mask table, set up with 019 option, will be drawn.

- Field 4 Length of pip in current linear measure units.
- Field 5 & 6 SPRD for first point.
- Field 7 Offset of centre of pip, measured normal to the string point.
- Field 8 & 9 SPRD for last point.
- Field 10 Angle of symbol.
- ◇ *If a geometry string label is specified, the pips are drawn at the geometry string points indicated by minor option 809, 'Geometry string annotation'.*
- ◇ *For geometry strings, the offset should be specified using minor option 809, 'Geometry string annotation'.*

## Minor option 861    Macrosymbol at string points

### Input

### Graphics

IGDRAWT.DAT, DRW018, DRW020

Annotation	Macrosymbols at string pts
Information along a string	String label
Information at points	Macrosymbol name
Pips	Width of macrosymbol
Macrosymbols at string pts	Start chainage / X coord
Scaled macrosymbols at pts	Start point no. / Y coord
Standard symbols at a point	Height of macrosymbol
Between string points	End chainage / X coord
Point sequence numbers	End point no. / Y coord
Chainages on 1 side only	Angle of symbol
Chainages on both sides	

### Linemode

#### Minor option 861

Field 1 Label of string; note that the string itself is not drawn, only the annotation.

Mask; all strings satisfying this mask will be drawn.  
If left blank all strings satisfying the current mask table, set up with 019 option, will be drawn.

Field 2 & 3 Macrosymbol name.

- If the macrosymbol name NULLSYMB is used, the macrosymbol is only drawn at points having a null level.  
 If the macrosymbol name ZEROSYMB is used, the macrosymbol is only drawn at points having a zero level.
- Field 4      Width of symbol.  
 If the width is positive drawing units (ie cms or inches) are used.  
 If the width is negative model units are used.
- Field 5 & 6    SPRD for first point.
- Field 7      Height of symbol.  
 If the height is positive drawing units (ie cms or inches) are used.  
 If the height is negative model units are used.
- Field 8 & 9    SPRD for last point.
- Field 10     Angle of symbol.
- ◇ *If a geometry string label is specified, the macrosymbol is drawn at the geometry string points indicated by minor option 809, 'Geometry string annotation'.*

## Minor option 862    Scaled macrosymbol at points

Draw a scaled macrosymbol at string points and use the value taken from a string point dimension to determine the size of the symbol.

### Input

### Graphics

IGDRAWT.DAT, DRW018, DRW021

Annotation	Scaled macrosymbol at pts
Information along a string	String label
Information at points	Macrosymbol name
Pips	Dimension number
Macrosymbols at string pts	Start chainage / X coord
Scaled macrosymbols at pts	Start point no. / Y coord
Standard symbols at a point	Scale for symbol
Between string points	End chainage / X coord
Point sequence numbers	End point no. / Y coord
Chainages on 1 side only	Angle of symbol
Chainages on both sides	

Linemode

Minor option 862

Field 1 Label of string; note that the string itself is not drawn, only the annotation.

Mask; all strings satisfying this mask will be drawn.

If left blank all strings satisfying the current mask table, set up with 019 option, will be drawn.

Field 2 & 3 Macroname

Field 4 The string dimension to be used to determine the size of the macrosymbol at each point.

Field 5 & 6 SPRD for first point.

Field 7 The scale to be used for the symbol, in the form 500.0 for 1:500 scale

Field 8 & 9 SPRD for last point.

Field 10 Angle of symbol.

◇ *If a geometry string label is specified, the macrosymbol is drawn at the geometry string points indicated by minor option 809, 'Geometry string annotation'.*

A special version of this minor option may be used to annotate geometry strings which include railway components switches. The component switch annotation is automatically scaled and positioned at the correct points.

**SwitchComponent annotation**

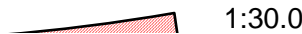
Minor option 862

Field 1 Label of geometry string containing railway components switches.

\* Field 2 SWITCHES

◇ *No SPRD may be specified with this option.*

◇ *All geometry strings meeting at the component switch(s) must be present.*



**Figure 3 - 158 Annotation of railway components**

Example 1

Hatching of curved railway components

```
MOSS // HATCH CURVED COMPONENTS
newd,hatch
draw,p30106 curve rail
800,4=1,84.100,59.400
802,4=5.000
803,PLAN,,NOTR,1.108,4149.636,8353.365,1000.000
802,4=0.5
```

807, red, 6=0.1, 0.1  
826  
862, g, swit, ches  
808, 4=0.18  
999  
FINISH

## Minor option 863 Standard symbol points

Draw standard symbol at string points.

### Input

### Graphics

IGDRAWT.DAT, DRW018, DRW022

Annotation	Standard symbol at a point
Information along a string	String label
Information at point:	Standard symbol number
Width	Width
Macrosymbols at string pt:	Start chainage / X coord
Scaled macrosymbols at pt	Start point no. / Y coord
Standard symbol at a point	End chainage / X coord
Between string point:	End point no. / Y coord
Point sequence number:	Angle of symbol
Chainages on 1 side only:	
Chainages on both side:	

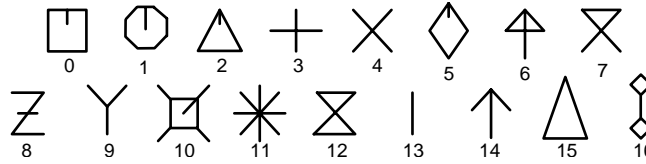
### Linemode

#### Minor option 863

- Field 1 Label of string; the string itself is not drawn, only the annotation.  
Mask; all strings satisfying this mask will be drawn.  
If blank all string satisfying the current 019 mask table, will be drawn.
- Field 2 Symbol number, coded left justified.
- Field 4 The width of the symbol in current linear measure units.
- Field 5 & 6 SPRD for first point.
- Field 8 & 9 SPRD for last point.
- Field 10 Angle of symbol.

- ◇ *If a geometry string label is specified, the standard symbol is drawn at the geometry string points indicated by minor option 809, 'Geometry string annotation'.*

The standard centred symbols are represented as follows:-



**Figure 3 - 159 Standard centred symbols**

**Example**

```
863,MAST,1,,1
863,CLEF,2,,1,10=90.0
863,CRIG,3,,1,10=-90.0
863,ILEF,4,,1
```



Minor option 864, 865, 866, 867, 868, and 869 Numerical annotation

- The numerical information may be
- 864 Between string points.
  - 865 Point sequence numbers.
  - 866 Chainages on one side only.
  - 867 Chainages on both sides.
  - 868 Spot levels.
  - 869 String dimension contents.

Minor option 864 Between string points

Annotate string between points with numerical information.

Input

Graphics

IGDRAWT.DAT, DRW018, DRW023

Annotation	Between string points
Information along a string	String label
Information at points	Dimension to be drawn
Chainages	Start chainage / X coord
Macrosymbols at string pt:	Start point no. / Y coord
Scaled macrosymbols at pt	Text offset
Standard symbols at a point	End chainage / X coord
Between string point:	End point no. / Y coord
Point sequence number:	Allowable difference
Chainages on 1 side only:	
Chainages on both side:	

Linemode

First record

Minor option 864

Field 1 Label of string; The string itself is not drawn, only the annotation.  
 Mask; all strings satisfying this mask will be drawn.  
 Blank; all strings satisfying the current 019 mask table, will be drawn.

- Field 2 Label of intersecting string where the annotation is to start. Cross sections only - if blank, annotation will begin from the start of each section.
- Field 3 Label of intersecting string where the annotation is to end. Cross sections only - if blank, annotation will continue to the last point on each section.
- Field 4 String dimension to be output eg 3 would give the level, 5.0 would give the cut label for a section string.  
Leave blank if you wish to use a text variable or place the annotation in a box. In this case, you should specify the string dimension to be output on a second 864 record.  
If a negative value is coded, values can be extracted from the string index or derived values may be drawn as follows:
- 1.0 String label
  - 2.0 Subreference
  - 3.0 String contents indicator
  - 4.0 Number of points in string
  - 5.0 Minimum x coordinate in string
  - 6.0 Minimum y coordinate in string
  - 7.0 Maximum x coordinate in string
  - 8.0 Maximum y coordinate in string  
Note that the same values would be drawn at every string point
  - 21.0 Distance between adjacent annotated points.
  - 22.0 Cumulative distance between annotated points.
  - 23.0 Percentage gradient between adjacent annotated points.
  - 24.0 Level difference between adjacent annotated points.
- Field 5 & 6 SPRD for first point of string to be drawn.
- Field 7 Text offset, measured from string to start of text in current linear measure units.
- Field 8 & 9 SPRD for last point on string to be drawn.
- Field 10 Maximum allowable difference. This refers to the value chosen in field 4 and limits the range of values being drawn. In particular:-  
If field 4 = -21 Code a minimum distance below which partial distance are omitted.  
If field 4 = -23 Code a maximum percentage gradient above which the grade information is omitted.  
If field 4 = -24 Code a maximum level difference beyond which level differences are omitted.
- ◇ *If a geometry string label is specified, the annotation is drawn between the geometry string points indicated by minor option 809, 'Geometry string annotation'.*

- ◇ For geometry strings, the offset should be specified using minor option 809, 'Geometry string annotation'.

A second record may be specified if you wish to use a text variable for the annotation, or if you wish to place the annotation in a box (provided Field 4 in the first 864 record is blank).

**Second record**

Minor option 864

Field 1	Box indicator
	BOX draw information inside a box
	NOBX draw information only
Field 3	Text variable name
Field 4	Dimension to be used
	See Field 4 in the first record for a full description.
Field 10	Angle of text
	If the angle is positive, text is positioned measured clockwise relative to the left hand side of the drawing. If negative, text is positioned clockwise relative to the normal lying to the left of the string.

- ◇ The second record must be followed by an 001 record specifying the text to be used.

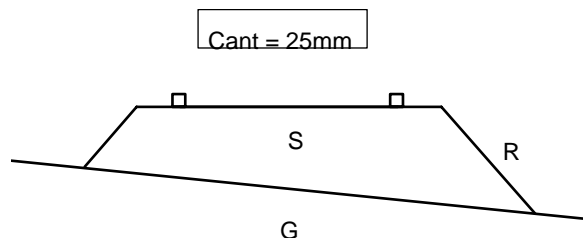
Minor option 001

Any text is permissible.

Example

The following example draws three sets of cross sections (reference letters G, R and S). Each end of section set S is annotated with standard symbol 0 (a square) drawn with a width of 0.5 units.

The level difference (ie, cant) between the two points is extracted, converted to millimetres and then placed in a box.



```
826 , R
826 , S
826 , G
863 , S , 0 , 4 = 0.5
809 , 4 = 13
864 , R , 7 = -2
864 , BOX , , CANT , -24 , 10 = 0.0
001 , Cant = &CANT& mm
```

## Minor option 865 Point sequence numbers

### Input

### Graphics

IGDRAWT.DAT, DRW018, DRW024

Annotation	Point sequence numbers
Information along a string	String label
Information at points	Innn / Dnnn
Pips	Start chainage / X coord
Macrosymbols at string pts	Start point no. / Y coord
Scaled macrosymbols at pts	Text offset (+ or -)
Standard symbols at a point	End chainage / X coord
Between string points	End point no. / Y coord
Point sequence numbers	Interval of annotation
Chainages on 1 side only	
Chainages on both sides	

### Linemode

#### Minor option 865

- Field 1 Label of string; the string itself is not drawn, only the annotation.  
Mask; all strings satisfying this mask will be drawn.  
Blank; all strings satisfying the current 019 mask table, will be drawn.
- Field 2 Position of text. The start of the text is computed by offsetting the required distance, normal to the string point.  
If omitted, the text will be drawn at the start position. To allow multiple sets of text to be associated with one string point, text can be moved up or down in multiples of the defined spacing relative to the start position.  
The spacing interval is defined on minor option 808.  
Code I followed by the number of lines (001 to 999) to move the text above the start position eg I004.  
Code D followed by the number of lines (001 to 999) to move the text below the start position eg D004.
- Field 5 & 6 SPRD for first point of string to be drawn.
- Field 7 Text offset, measured from string to start of text in current linear measure units.
- Field 8 & 9 SPRD for last point on string to be drawn.

Field 10 Interval of annotation; if omitted all points are marked.

- ◇ For geometry strings, the offset should be specified using minor option 809, 'Geometry string annotation'.

## Minor option 866 Chainages on 1 side only

Draw chainage and pip marks at points on a master alignment string.

### Input

### Graphics

IGDRAWT.DAT, DRW018, DRW025

Annotation	Chainages on 1 side only
Information along a string	String label
Information at points	Innn / Dnnn
Pips	Pip length
Macrosymbols at string pts	Start chainage / X coord
Scaled macrosymbols at pts	Start point no. / Y coord
Standard symbols at a point	Text offset (+ or -)
Between string points	End chainage / X coord
Point sequence numbers	End point no. / Y coord
Chainages on 1 side only	Chainage interval
Chainages on both sides	

### Linemode

#### Minor option 866

Field 1 Label of string; The string itself is not drawn, only the annotation.  
Mask; all strings satisfying this mask will be drawn.  
Blank; all strings satisfying the current 019 mask table will be drawn.

Field 2 Position of text. The starting position of the text to be drawn is calculated by offsetting the required distance, normal to the string point.

If omitted, the text will be drawn at the start position.  
To allow multiple sets of text to be associated with one string point, text can be moved up or down in multiples of a defined spacing relative to the start position.  
The spacing interval is defined on minor option 808.

Code I followed by the number of lines (001 to 999) to move the text above the start position eg I004.  
Code D followed by the number of lines (001 to 999) to move the text below the start position eg D004.

- Field 4 Length of pip in current linear measure units, pip is drawn centred on string point.
  - Field 5 & 6 SPRD for first point on string to be drawn, if omitted start of string is assumed.
  - Field 7 Text offset, measured from string to start of text in current linear measure units.
  - Field 8 & 9 SPRD for last point on string to be drawn, if omitted end of string is assumed.
  - Field 10 Chainage marking interval. Chainages are drawn at multiples of this interval. The default marking interval is held on the parameter file under keyword DCHMAINT.
- ◇ *For geometry strings, the offset should be specified using minor option 809, 'Geometry string annotation'.*

## Minor option 867 Chainages on both sides

Draw chainages with pips on both sides of a master alignment string.

### Input

### Graphics

IGDRAWT.DAT, DRW018, DRW026

Annotation	Chainages on both sides
Information along a string	String label
Information at points	Innn / Dnnn
Pips	Pip length
Macrosymbols at string pts	Start chainage / X coord
Scaled macrosymbols at pts	Start point no. / Y coord
Standard symbols at a point	Pips and text offset
Between string points	End chainage / X coord
Point sequence numbers	End point no. / Y coord
Chainages on 1 side only	Chainage interval
Chainages on both sides	

Linemode

Minor option 867

- |             |   |
|-------------|---|
| Field 1     | Label of string; note that the string itself is not drawn, only the annotation.<br>Mask; all strings satisfying this mask will be drawn.<br>Blank; all strings satisfying the current 019 mask table will be drawn.   |
| Field 2     | Position of text. The starting position of the text to be drawn is computed by offsetting the required distance, normal to the string point.<br><br>If omitted, the text will be drawn at the start position. To allow multiple sets of text to be associated with one string point, text can be moved up or down in multiples of a defined spacing relative to the start position.<br>The spacing interval is defined on minor option 808.<br>Code I followed by the number of lines (001 to 999) to move the text above the start position eg I004.<br>Code D followed by the number of lines (001 to 999) to move the text below the start position eg D004. |
| Field 4     | Length of pip in current linear measure units.  |
| Field 5 & 6 | SPRD for first point on string to be drawn, if omitted start of string is assumed.  |
| Field 7     | Text offset, measured from string to start of text in current linear measure units.   |
| Field 8 & 9 | SPRD for last point on string to be drawn; if omitted end of string is assumed.   |
| Field 10    | Chainage marking interval. Chainages are drawn at multiples of this interval. The default marking interval is held on the parameter file under keyword DCHMAINT.  |
- ◇ *For geometry strings, the offset should be specified using minor option 809, 'Geometry string annotation'.*

**Minor option 868   Spot levels**

Draw contents of a string dimension, with a cross at a string point (spot level notation).

Input

Graphics

IGDRAWT.DAT, DRW018, DRW027

Annotation	Spot levels
Chainages on both sides	String label
Spot levels	Innn / Dnnn
String dimension content	String dimension
	Start chainage / X coord
	Start point no. / Y coord
	Text offset (+ or -)
	End chainage / X coord
	End point no. / Y coord
	Angle of text

Linemode

Minor option 868

Field 1 Label of string; note that the string itself is not drawn, only the annotation.

Mask; all strings satisfying this mask will be drawn.

Blank; all strings satisfying the current 019 mask table will be drawn.

Field 2 Position of text. The starting position of the text to be drawn is computed by offsetting the required distance, normal to the string point.

If omitted, the text will be drawn at the start position. To allow multiple sets of text to be associated with one string point, text can be moved up or down in multiples of a defined spacing relative to the start position.

The spacing interval is defined on minor option 808.

Code I followed by the number of lines (001 to 999) to move the text above the start position I 004.

Code D followed by the number of lines (001 to 999) to move the text below the start position eg D004.

Field 4 Dimension of string to be drawn eg 3.0 would give the level, 5.0 would give the cut string label for a section string.

If a negative value is coded, values can be extracted from the string index or derived values can be drawn as follows:

-1.0 String label



- 2.0 Subreference
  - 3.0 String contents indicator
  - 4.0 Number of points in string
  - 5.0 Minimum x coordinate in string
  - 6.0 Minimum y coordinate in string
  - 7.0 Maximum x coordinate in string
  - 8.0 Maximum y coordinate in string
- Note that the same values would be drawn at every string point

Also:

- 11.0 Point sequence number
- 21.0 Distance between adjacent points
- 22.0 Cumulative distance between adjacent points (long sections only)
- 23.0 Percentage gradient between adjacent points for geometry strings
- 25.0 Radius or RL value
- 46.0 Horizontal tangent point start/end labels (geometry strings only). The labels used are defined in the parameter file.
- 47.0 Vertical tangent point start/end labels (geometry strings only)  
The labels used are defined in the parameter file.

Field 5 & 6 SPRD for first point on string to be drawn; if omitted start of string is assumed.

Field 7 Text offset, measured from string to start of text in current linear measure units.

Field 8 & 9 SPRD for last point on string to be drawn; if omitted end of string is assumed.

Field 10 Angle of text.

If the angle is positive, text is positioned measured clockwise relative to the left hand side of the drawing. If negative, text is positioned clockwise relative to the normal lying to the left of the string.

- ◇ *For 868, 4=-25 if this field is blank, annotation will appear on the inside of string curves, normal to the string.*
- ◇ *If a geometry string label is specified, the spot levels are drawn at the geometry string points indicated by minor option 809, 'Geometry string annotation'.*
- ◇ *For geometry strings, the offset should be specified using minor option 809, 'Geometry string annotation'.*

Example 1

868,MAST,4=3,7=-2  
868,MAST,4=4,7=0.5

Example 2

809,VFPS  
868,GAST,4=-21  
868,GAST,4=-23

Minor option 869 String dimension content

Draw contents of a string dimension, without a cross at a string point.

Input

Graphics

IGDRAWT.DAT, DRW018, DRW028

Annotation	String dimension content
Chainages on both sides	String label
Spot levels	Innn / Dnnn
String dimension content	String dimension
	Start chainage / X coord
	Start point no. / Y coord
	Text offset (+ or -)
	End chainage / X coord
	End point no. / Y coord
	Angle of text

Linemode

This option is used in different ways when used with any string and cadastre string types. Examples follow:-

**Any string**

Minor option 869

Field 1 Label of string; note that the string itself is not drawn, only the annotation.  
Mask; all strings satisfying this mask will be drawn.  
Blank; all strings satisfying the current 019 mask table will be drawn.

- Field 2      Position of text. The starting position of the text to be drawn is computed by offsetting the required distance, normal to the string point.  
If omitted, the text will be drawn at the start position. To allow multiple sets of text to be associated with one string point, text can be moved up or down in multiples of a defined spacing relative to the start position.  
The spacing interval is defined on minor option 808.  
Code I followed by the number of lines (001 to 999) to move the text above the start position eg I004.  
Code D followed by the number of lines (001 to 999) to move the text below the start position eg D004.
- Field 4      Dimension of string to be drawn eg 3.0 would give the level, 5.0 would give the cut string label for a section string.  
If a negative value is coded, values can be extracted from the string index or derived values can be drawn as follows:
- 1.0      String label
  - 2.0      Subreference
  - 3.0      String contents indicator
  - 4.0      Number of points in string
  - 5.0      Minimum x coordinate in string
  - 6.0      Minimum y coordinate in string
  - 7.0      Maximum x coordinate in string
  - 8.0      Maximum y coordinate in string
- Note that the same values would be drawn at every string point
- Also:
- 11.0     Point sequence number
  - 21.0     Distance between adjacent points
  - 22.0     Cumulative distance between adjacent points (long sections only)
  - 23.0     Percentage gradient between adjacent points for Geometry Strings
  - 25.0     Radius, or 'A' or 'RL' value (dependent upon the setting in the parameter file)
  - 46.0     Horizontal tangent point start/end labels (geometry strings only). The labels used are defined in the parameter file.
  - 47.0     Vertical tangent point start/end labels (geometry strings only)  
The labels used are defined in the parameter file.
- The remaining dimensions are valid for geometry strings only:
- 70.0     HIP X coordinate
  - 71.0     HIP Y coordinate

- 72.0 HIP level
- 73.0 HIP chainage
- 74.0 HIP tangent length
- 75.0 HIP length of whole curve  
(curve and transitions)
- 76.0 HIP deflection angle
- 77.0 HIP whole circle bearing
- 78.0 HIP long chord
- 79.0 HIP curve to chord distance
- 80.0 HIP semi-deflection angle  
(deflection angle / 2)
- 81.0 HIP to curve length
- Field 5 & 6 SPRD for first point on string to be drawn; if omitted start of string is assumed.
- Field 7 Text offset, measured from string to start of text in current linear measure units.
- Field 8 & 9 SPRD for last point on string to be drawn; if omitted end of string is assumed.
- Field 10 Angle of text.  
If the angle is positive, text is positioned measured clockwise relative to the left hand side of the drawing. If negative, text is positioned clockwise relative to the normal lying to the left of the string.
- ◇ *If this is a geometry string and Field 10 is blank, the offset is measured to the nearest edge of the text.*
- ◇ *For geometry strings, the offset should be specified using minor option 809, 'Geometry string annotation'.*
- ◇ *If a geometry string label is specified, the spot levels are drawn at the geometry string points indicated by minor option 809, 'Geometry string annotation'.*
- ◇ *If the angle of text is not specified, annotation will appear on the inside of string curves and normal to the string when Field 4 is set to any of the following:*

869,4=-25  
869,4=-46.0  
869,4=-47.0

### Cadastre strings

#### Minor option 869

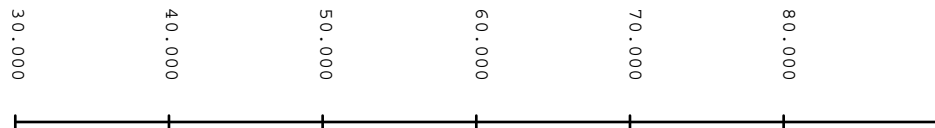
- Field 1 Cadastre string label/partial label
- Field 2 Position of text
- Field 3 Feature code  
A partial feature code may be specified.

Field 4	Dimension to be drawn
	1 X coordinate
	2 Y coordinate
	3 Z coordinate
	4 Symbol reference bearing
	5 Survey point number
	6 Point feature code
	7 Cadastre point number
Field 6	Start point number
Field 7	Text offset, measured from string to start of text in current linear measure units.
Field 9	End point number
Field 10	Angle of text

Example 1

**Any string**

869,mast,4=3,10=-90  
 869,mast,4=4,7=-1.5,10=-90



**Figure 3 - 160 String dimension content (any string)**

Example 2

**Cadastre string**

869,p001,i002,4=5,7=0,,2,0  
 869,p001,i001,4=7,7=0,,2,0

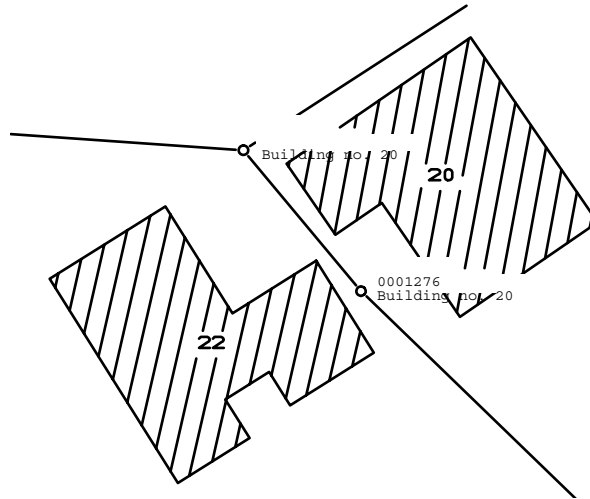


Figure 3 - 161 String dimension content (cadastre string)

### Minor option 870 - 879 Draw hatching

The hatching drawn may be:

- 870            Fill triangulation
- 875            Between two strings
- 877            Between two lines
- 878            Between two lines
- 879            Inside a boundary string

If the hatching interval is less than 0.01 (as defined in option 807), the area defined will be solid filled with colour.

### Minor option 870    Fill triangulation

This minor option allows you to colour fill triangles created by major option TRIANGLE.

#### Input

#### Graphics

IGDRAWT.DAT, DRW006, DRW036, DRW038

Add drawing details	Triangulation options	Fill triangulation
Annotation	Draw triangulation	Triangulation label
Draw cadastral symbols	Fill triangulation	Group name/NULL/UNGP
Hatching	End DRAW	Draw triangles (T)
Grids/Frames		Lower level
Text strings		Upper level
Draw selected strings		Start slope
Draw null/zero levels		End slope
Draw contour strings		Start bearing
Triangulation options		End bearing
Draw drainage network		

#### Linemode

##### Minor option 870

- \* Field 1            Triangulation label.
- Field 2            Group name of triangles or  
NULL - if only null triangles are to be filled.  
UNGP - if only ungrouped triangles are to be filled.
- Field 4            Draw/not draw triangulation.  
+1.0 - draw (default)  
-1.0 - do not draw.

- Field 5      Lower level, above which all triangles are filled.
  - Field 6      Upper level, below which all triangles are filled.
  - Field 7      Start slope (decimal fraction), above which triangles are filled.
  - Field 8      End slope (decimal fraction), below which triangles are filled.
  - Field 9      Start whole circle bearing for aspect.
  - Field 10     End whole circle bearing for aspect.
- ◇ *Field 4 can be coded -1.0 if the triangulation has been previously drawn with option 827.*
  - ◇ *Fields 7 and 8 must be zero or positive.*
  - ◇ *Flat triangles are included in the colour fill when whole circle bearings are specified.*

**Example**

Hatch triangles between levels of 27 and 35m whose angle of slope is between 0.025 (1 in 40) and 0.05 (1 in 20) and only those that are sloped towards an angle between the bearings of 45 and 90 degree.

```
870 , TRIG, 4=-1 , 27.0 , 35.0 , 0.025 , 0.05 , 45.0 , 90.0
```

**Minor option 875, 876 Hatch between two strings**

**Input**

Graphics

IGDRAWT.DAT, DRW029, DRW030, DRW031

Hatching options	Between two strings	Between two strings
Between two strings	First string label	Second string label
Between two lines	Hatching label	Start chainage / X coord
Inside a boundary string	Start chainage / X coord	Start point no. / Y coord
End DRAW	Start point no / Y coord	End chainage / X coord
	End chainage / X coord	End point no. / Y coord
	End point no. / Y coord	
	Enclose hatching (T)	

- ◇ *When you have completed 'Between two strings 785', proceed will cause display of 'Between two strings 876'.*



Linemode

Details of first string and hatching details - 875

Details of second string - 876

Minor option 875

- \* Field 1      First string label.
- Field 3      Hatching label (optional).
- Field 5 & 6   SPRD for first point.
- Field 7      Boundary indicator.
  - 1.0          draw boundary
  - 1.0        do not draw boundary

Field 8 & 9   SPRD for last point.

◇ *Hatching interval and angle are now defined by option 807*

Minor option 876

- \* Field 1      Second string label.
- Field 5 & 6   SPRD for first point.
- Field 8 & 9   SPRD for last point.

Minor option 877, 878 Hatch between two lines

Input

Graphics

IGDRAWT.DAT, DRW029, DRW032, DRW033

Hatching options	Between two lines	Between two lines
Between two strings	Hatching label	Line 2    X coord 1
Between two lines	Line 1    X coord 1	Y coord 1
Inside a boundary string	Y coord 1	Line 2    X coord 2
End DRAW	Line 1    X coord 2	Y coord 2
	Y coord 2	
	Enclose hatching (T)	

◇ *When you have completed 'Between two lines', proceed will cause display of the second 'Between two lines' menu.*

Linemode

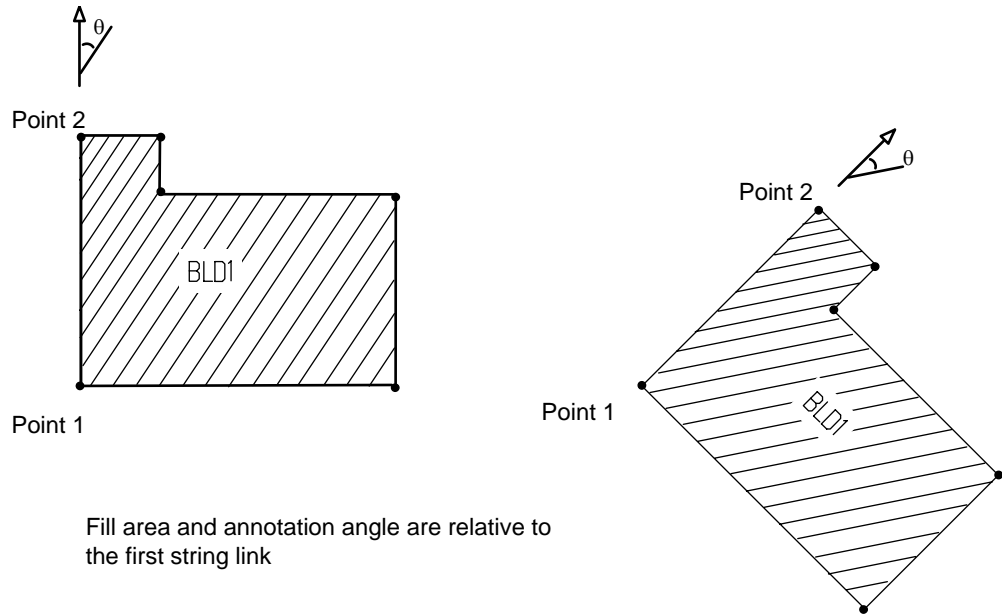
- Details of first line and hatching details - 877
- Details of second line - 878
- Minor option 877
- Field 3        Hatching label (optional).
- \* Field 5 & 6    Start of line 1 (model coordinates).
- Field 7        Boundary indicator.
  - 1.0            draw boundary
  - 1.0          do not draw boundary
- \* Field 8 & 9    End of line 1 (model coordinates).
  - ◇ *Hatching interval and angle are defined by option 807*
- Minor option 878
- \* Field 5 & 6    Start of line 2 (model coordinates).
- \* Field 8 & 9    End of line 2 (model coordinates).

**Minor option 879    Fill area inside a boundary string**

This option performs a fill area within a boundary. The fill area may be drawn at an angle relative to the drawing sheet or relative to the first string link of the boundary. To define the fill area used within the boundary, use minor option 807 'Fill area characteristics'.

Any string may be used to form the boundary. If the boundary is not complete, the fill area will automatically form a closed boundary itself.

In addition, the fill area may be annotated with the string sub-reference. This can also be drawn relative to the sheet or relative to the first string link of the boundary.

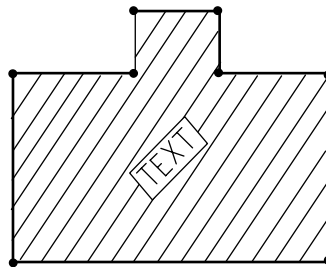


Fill area and annotation angle are relative to the first string link

**Figure 3 - 162 Hatch relative to a string link**

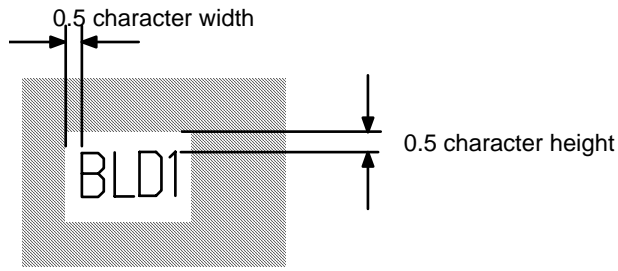
If the fill area and text angles are specified relative to the first string link, this ensures that the orientation of the fill area and text in a copied string is maintained.

The text annotation is placed at the fill area centroid, although it can be moved using MOVCOPI. The annotation is placed in a box which forms a second boundary with the fill area.



Fill area is inside the first boundary and outside the second boundary

**Figure 3 - 163 Text annotation within a fill area**



**Figure 3 - 164 Automatic text box scaling**

The box is automatically scaled according to the size of the text within it.

**Input**

Graphics

IGDRAWT.DAT, DRW029, DRW034

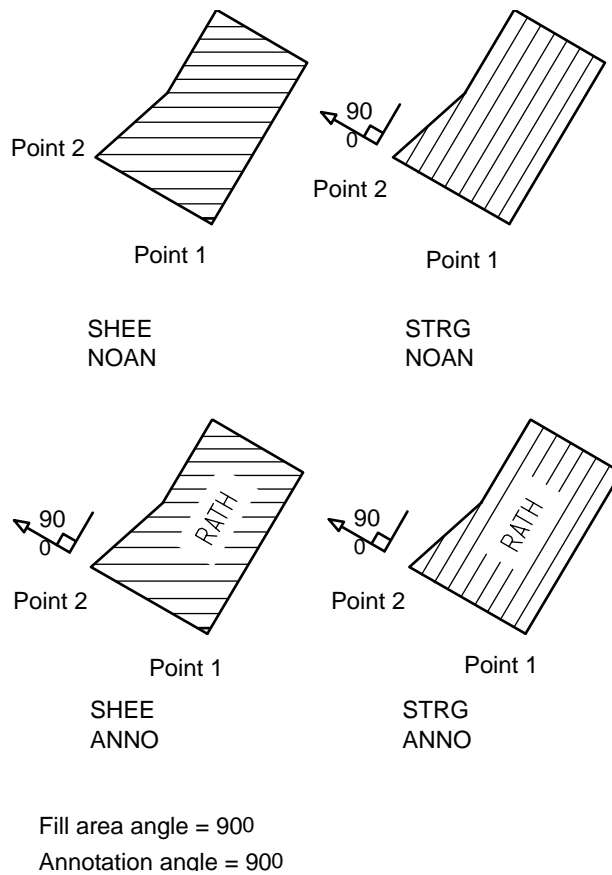
Hatching options	Inside a boundary string
Between two strings	String label
Between two lines	Enclose area fill (T)
Inside a boundary string	Fill angle relative to (T)
End DRAW	Annotate with subref (T)
	Annotation angle

Linemode

Minor option 879

- Field 1 Label or partial label of string(s) forming boundary.
  - ◇ *If the area to be filled is not already enclosed, it is closed automatically by the fill.*
- Field 2 Fill area angle indicator
  - SHEE Fill area relative to sheet (default)
  - STRG Fill area relative to first string link
- Field 3 Annotation indicator
  - NOAN No annotation (default)
  - ANNO Annotate with string sub-reference
- Field 7 Boundary indicator.

- 1.0 draw boundary (default)
- 1.0 do not draw boundary
- Field 10 Annotation angle
  - Positive Text drawn at the specified angle relative to sheet (default 0)
  - Negative Text drawn at the specified angle relative to the first string link.
- ◇ *Fill area interval and angle are defined by minor option 807, 'Fill area characteristics'*



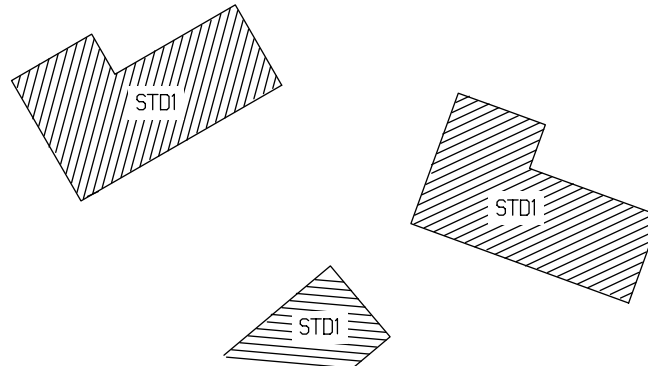
**Figure 3 - 165 Fill area angle indicator values**

**Example**

All strings starting with BD have their sub-reference changed to STD1. These strings are area filled with green hatching, at 45 degrees to the first string link of each of the strings. The strings are annotated with their sub-reference at the default text angle of 0 degrees relative to the sheet edge.

```
EDIT, HOUSING LAYOUT
033, BD, , STD1
999
DRAW, HOUSING LAYOUT
801, OVER
```

807, GREE, 7=0.5, 10=45  
879, BD, STRG, ANNO, 7=-1  
999



**Figure 3 - 166 Hatched and annotated buildings**

## Draw using a macro

This option is only available in graphics. It allows you to enter and action macros such as:

PLANDRAW  
PLANLINE  
LONGDRAW  
LONGLINE  
SECTDRAW  
SECTLINE  
SURVDRAW  
MASSDRAW

**IGDRAWT.DAT, DRW004, DRW005**

<b>DRAW - Option details</b>	<b>Draw using a macro</b>
<b>Model for DRAW</b>	<b>Macroname</b>
Draw all strings	
Draw all strings (DETA)	
Draw selected strings	
Draw raster backcloth	
Draw using a macro	
Define a boundary	
Add drawing details	
Create new sheet	
End Draw	

Full documentation on this option is included earlier in this chapter.

# ENHANCE macros

## The use of macro commands

Major option ENHANCE provides complete flexibility over the addition of enhancements to drawings, and this flexibility is achieved by a number of minor option commands. There are, however, a number of enhancements which occur more frequently than others and in order to simplify the use of ENHANCE in LINEMODE, macros are supplied. The macros available in ENHANCE are:-

- LINETEXT Addition of 1 line of text or simple block text
- DRAWCIRC Circle defined by centre and radius.
- DRAWCIRP Circle defined by centre and point on circumference.
- DRAWCIR2 Circle defined by two points and radius.
- DRAWCIRD Circle defined by two points on a diameter.
- DRAWCIR3 Circle defined by three points.
- DRAWARCC Arc defined by centre and radius.
- DRAWARCP Arc defined by centre and point on circumference.
- DRAWARC2 Arc defined by two points and radius.
- DRAWARCD Arc defined by two points on a diameter.
- DRAWARC3 Arc defined by three points.

Data input to a macro uses two character field descriptors for individual items of data.

For example:-

RA = 5.0 would infer a radius of 5.0

There are some simple rules to follow in assigning data to variables.

- All fields must be separated by commas.
- There must be no blanks between fields.
- If an assignment is to be made to a character variable and the value contains embedded blanks, then the value must be surrounded by single quotes.  
For example TN='SOME TEXT'
- As many variable assignment records may be used as are necessary but each must terminate with a comma except the last which must end with a blank.
- If a variable name exists within a macro and no value is assigned, the field descriptor will appear in the expanded record and the data may well fail.



- To differentiate input derived from macros from standard input data, the derived minor options are marked with an M.

### Data preparation

Attributes may be assigned but if they are not relevant or of no interest they may be ignored.

In the following PV implies any Positive Value  
CV implies any Character Value

If data is **mandatory** it is shown in CAPITAL LETTERS.

## Macro LINETEXT

◇ *Character colour and style should be set using 806/808 before using this macro.*

Example of use

```
900,LINETEXT
UT='', XS=10.0, YS=10.0, TN='SOME TEXT'
```

### Input data

Code	Description	Alternatives	Default
TN	TEXT TO BE WRITTEN	CV	-
XS	START POINT COORDINATES	PV	-
YS			
XE	End point coordinates	PV	-
YE			
BE	Angle of text relative to LHS	PV	"
BX	To box the text	B	-
		-	
LB	Picture object label	CV	
UT	Unjustified text	"	-
JT	Justified text (either UT=" or JT=" should be coded)	"	-
PS	Justification of text (only applicable if JT=" coded)		CC
	Top left	LT	
	Top centre	CT	
	Top right	RT	
	Centre left	LC	
	Centre centre	CC	
	Centre right	RC	
	Bottom left	LB	
	Bottom centre	CB	
	Bottom right	RB	

The LINETEXT macro may be used both for the addition of a single line of text or for the addition of simple blocked text. For a single line of text the text is defined within the macro. For multiple lines of text the first line is

defined within the macro but subsequent lines are defined on an option 884 record as follows.

**Minor option 884**

Field 1        Code D00n to decrease by n lines.  
                  I00n to increase by n lines.  
                  (n can take any value between 0 and 99)

Field 2 - 10    Text to be output.

**Example**

```
900,LINETEXT
TN='FIRST LINE OF TEXT', XS=22,YS=24,UT=' '
884,D001,SECOND LINE OF TEXT
884,D002,THIRD LINE OF TEXT
```

**Examples**

To demonstrate the simple use of the LINETEXT macro a typical set of text enhancements are given. The following cases are described and illustrated in Figure 3 - 167.

1.            Add a single line with no orientation            (Type A)
2.            Add a single line angled along a reference line (Type B)
3.            Add a small block of text with no orientation (Type C)
4.            Add a single line repetitively                    (Type D)
5.            Add a block of text                                    (Type E)

```
810
808,4=0.4
900,LINETEXT
TN='Rough Grass',XS=12,YS=15,UT=' '
900,LINETEXT
TN='ST PETERS
CLOSE',XS=6.8,YS=9.7,XE=11.6,YE=9.0,JT=' '
808,4=0.2
900,LINETEXT
TN='Access Road
Only',XS=2.8,YS=20,XE=3.5,YE=15.4,JT=' '
900,LINETEXT
TN='Access',XS=11.3,YS=6.7,UT=' '
884,D001,To
884,D002,Garages
900,LINETEXT
TN='Steps',XS=27.9,YS=5.3,XE=28.3,YE=7.0,JT=' '
900,LINETEXT
TN='Steps',XS=28.3,YS=7.0,XE=28.7,YE=8.2,JT=' '
900,LINETEXT
TN='Steps',XS=28.7,YS=9.4,XE=28.7,YE=11.2,JT=' '
900,LINETEXT
```

```
TN='        COORDINATE SCHEDULE',XS=22,YS=24,BX=B,UT=""
884,D001 Stn    EASTING    NORTHING    HEIGHT    DESCRIPTION
884,D002, 1 166.195        100.000        54.311    Disc Mark
```

884,D003,	2	100.000	100.000	56.686	Disc Mark
884,D004,	3	119.255	111.411	56.037	Peg
884,D005,	4	99.000	125.344	53.014	Disc Mark
884,D006,	5	141.226	122.190	52.348	Peg
884,D007,	6	202.004	98.418	51.478	Peg
884,D008,	7	225.123	97.614	50.767	Peg
884,D009,	8	220.300	75.016	58.797	Disc Mark
884,D010,	9	215.159	142.772	40.620	Disc Mark
884,D011,	Level 1 datum 0584 on site value 56.60m				

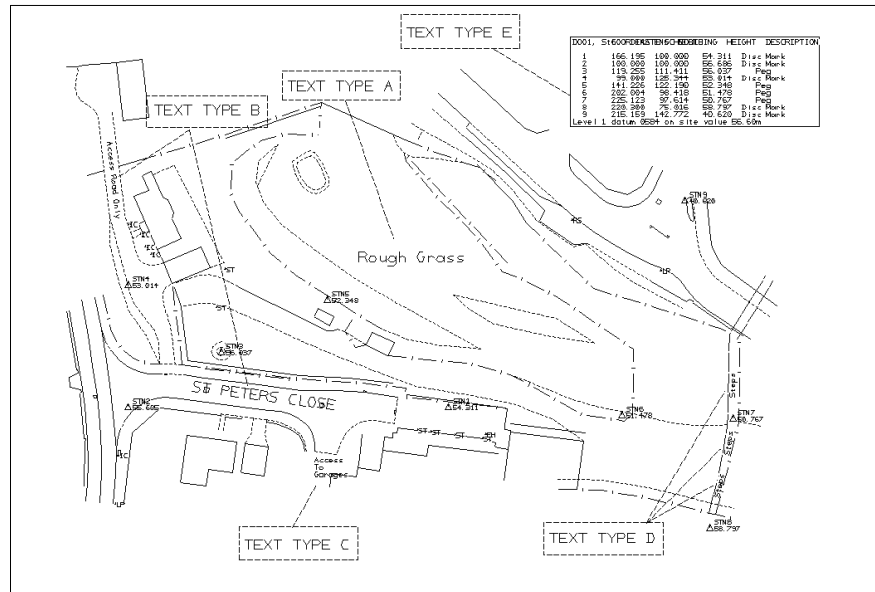


Figure 3 - 167 Example of LINETEXT enhancements

### Macro Input data

The LINETEXT macro may be reported by invoking the following commands. A set of minor options will also be generated which may be modified by the user if required.

```

MACRO
903 , LINETEXT , FILE
999

```

### Macros to draw circles and arcs

◇ *Line style and colour should be set using 805/810 before using these macros.*

<b>CIRCLES</b>	<b>Circles defined by</b>
DRAWCIRC	centre and radius
DRAWCIRP	centre and point on circumference

DRAWCIR2	two points and radius
DRAWCIRD	points on a diameter
DRAWCIR3	three points
<b>ARCS</b>	<b>Arcs defined by</b>
DRAWARCC	centre and radius
DRAWARCP	centre and point on circumference
DRAWARC2	two points and radius
DRAWARCD	points on a diameter
DRAWARC3	three points

**DRAWCIRC (centre and radius)**

Code	Description	Alternatives	Default
XC	CENTRE COORDINATES	PV	-
YC		PV	-
RA	RADIUS	PV	-
LB	Picture element label	CV	-

**DRAWCIRP (centre and point on circumference)**

Code	Description	Alternatives	Default
XC	CENTRE COORDINATES	PV	-
YC		PV	-
XP	POINT ON CIRCUMFERENCE	PV	-
YP		PV	-
LB	Picture element label	CV	-

**DRAWCIR2 (two points and radius)**

Code	Description	Alternatives	Default
X1	FIRST POINT COORDINATES	PV	-
Y1		PV	-
X2	SECOND POINT COORDINATES	PV	-
Y2		PV	-
RA	RADIUS	PV	-
LB	Picture element label	CV	-

**DRAWCIRD (two points on a diameter)**

Code	Description	Alternatives	Default
X1	FIRST POINT COORDINATES	PV	-
Y1		PV	-
X2	SECOND POINT COORDINATES	PV	-
Y2		PV	-
LB	Picture element label	CV	-

**DRAWCIR3 (three points)**

Code	Description	Alternatives	Default
X1	FIRST POINT COORDINATES	PV	-

Y1		PV	-
X2	SECOND POINT COORDINATES	PV	-
Y2		PV	-
X3	THIRD POINT COORDINATES	PV	-
Y3		PV	-
LB	Picture element label	CV	-

**DRAWARCC (arc defined by centre and radius)**

Code	Description	Alternatives	Default
XC	CENTRE COORDINATES	PV	-
YC		PV	-
RA	RADIUS	PV	-
LB	Picture element label	CV	-
XS	Start point coordinates	PV	-
YS	or	PV	-
BS	Bearing of start of arc (line drawn from centre)	PV	-
XE	End point coordinates	PV	-
YE	or	PV	-
BE	Bearing of end of arc (line drawn from centre)	PV	-

**DRAWARCP (arc defined by centre and a point on circumference)**

Code	Description	Alternatives	Default
XC	CENTRE COORDINATES	PV	-
YC		PV	-
XP	COORDINATES OF POINT ON	PV	-
YP	CIRCUMFERENCE	PV	-
LB	Picture element label	CV	-
XS	Start point coordinates	PV	-
YS	or	PV	-
BS	Bearing of start of arc (line drawn from centre)	PV	-
XE	End point coordinates	PV	-
YE	or	PV	-
BE	Bearing of end of arc (line drawn from centre)	PV	-

**DRAWARC2 (arc defined by two points and radius)**

Code	Description	Alternatives	Default
X1	FIRST POINT COORDINATES	PV	-
Y1		PV	-
X2	SECOND POINT COORDINATES	PV	-
Y2		PV	-
RA	RADIUS	PV	-
LB	Picture element label	CV	-
XS	Start point coordinates	PV	-
YS	or	PV	-
BS	Bearing of start of arc (line drawn from centre)	PV	-

XE	End point coordinates	PV	-
YE	or	PV	-
BE	Bearing of end of arc (line drawn from centre)	PV	-

The arc is drawn from the first point defined to the second point in the direction of the hand of the defined radius (ie positive - clockwise; negative - anti-clockwise). If (XS,YS), BS, (XE,YE), or BE are undefined the specifying coordinates are used.

**DRAWARCD (arc defined by two points on a diameter)**

Code	Description	Alternatives	Default
X1	FIRST POINT COORDINATES	PV	-
Y1		PV	-
X2	SECOND POINT COORDINATES	PV PV	-
Y2			-
LB	Picture element label	CV	-
XS	Start point coordinates	PV	-
YS	or	PV	-
BS	Bearing of start of arc (line drawn from centre)	PV	-
XE	End point coordinates	PV	-
YE	or	PV	-
BE	Bearing of end of arc (line drawn from centre)	PV	-

**DRAWARC3 (arc defined by three points)**

Code	Description	Alternatives	Default
X1	FIRST POINT COORDINATES	PV	-
Y1		PV	-
X2	SECOND POINT COORDINATES	PV	-
Y2		PV	-
X3	THIRD POINT COORDINATES	PV	-
Y3		PV	-
LB	Picture element label	CV	-
XS	Start point coordinates	PV	-
YS	or	PV	-
BS	Bearing of start of arc (line drawn from centre)	PV	-
XE	End point coordinates	PV	-
YE	or	PV	-
BE	Bearing of end of arc (line drawn from centre)	PV	-

If (XS,YS), BS, (XE,YE) or BE are undefined the first and last specifying coordinates are used. The arc is drawn from the first point to the third point through the second point

**Examples**

```
900 ,DRAWCIRD
X1=5 , Y1=15 , X2=15 , Y2=20
900 ,DRAWARCD
```

```
X1=7, Y1=7, X2=12, Y2=12, BS=235., XE=7, YE=12
900, DRAWARC3
X1=15, Y1=15, X2=20, Y2=20, X3=25, Y3=15
```

### Macro input data

The macros to draw circles and arcs may be reported by invoking the following commands. A set of minor options will also be generated which may be modified by a user if required.

```
MACRO
903, DRAWCIRC, FILE
903, DRAWCIRP, FILE
903, DRAWCIR2, FILE
903, DRAWCIRD, FILE
903, DRAWCIR3, FILE
903, DRAWARCC, FILE
903, DRAWARCP, FILE
903, DRAWARC2, FILE
903, DRAWARDC, FILE
903, DRAWARC3, FILE
999
```

## Major option ENHANCE

The inclusion of additional notes, construction lines and symbols is an integral part of drawing production. Complex enhancements may be added to drawings from simple basic elements of arcs, lines and text. Major option ENHANCE is provided to add non-model information to a drawing.

The ENHANCE options operate on the Drawing Picture File produced by major option DRAW.

The difference between major options DRAW and ENHANCE may be summarised as:-

DRAW adds Model related information to the drawing.

ENHANCE adds Picture related information to the drawing.

Thus the operation of ENHANCE is totally separate from model information.

The most common use of ENHANCE is in IGMODE, where the facilities are accessed by selecting functions from the static and dynamic menu areas, but each feature may be simulated in LINEMODE, allowing commonly used sets of enhancement such as drawing frames to be created and used repeatedly.

The options provided include:-

- Selection of Drawing Environment.
  - Line Characteristics
  - Text Characteristics
  - Object/Element Definition
- Enhancement Features
  - Adding, moving and duplicating text.
  - Adding, moving and duplicating symbols.
  - Adding, moving and duplicating boxes, circles and lines.

### Selection of drawing environment

Drawings are enhanced by adding blocks of information such as text and boxes. Associated with each block are environment attributes which describe the physical appearance of it. For example a block may consist of text of a specified character height of a particular colour. Attributes once set often retain the same values for different blocks of information. For instance, once a suitable character size is chosen it may be retained even though the colours may be changed.

A typical series of instructions would be:-

Draw text in default text colour and size.  
Change text colour to blue.  
Draw subsequent text in blue.  
Change text style.



At any point in the production of a drawing the drawing environment may be changed and the reset values will remain in force until modified.

The environment attributes are controlled by minor options 805-810 as follows:-

805	Pen type and colour for lines.
806	Pen type and colour for text.
807	Hatch fill area characteristics
808	Text font, style and size.
810	Line style.

The addition of guidance notes and symbolic data to drawings is an important aspect of drawing production. Whilst the basic elements of such enhancement are very simple, eg arcs, lines and text, enhancements may be built up into complex 'objects' and manipulated and moved around the drawing.

Users may choose to collect enhancements together within objects. Object facilities are provided by options:-

814	Begin an object.
815	Close an object.

## Enhancement options

When major option ENHANCE is invoked a number of options are available to the user. These options fall into obvious groupings and within each group a number of variations is allowed. The following sections initially describe the basic functionality and subsequently illustrate the flexibility with which to use the options.

- ◇ *Coordinates specified in ENHANCE are drawing units, not modelling units.*

### Summary of options

- Arcs and circles
- Boxes
- Frames and meshes
- Lines / polylines
- Text / polytext
- Macrosymbols
- Standard symbols
- Hatching

### Arcs and circles

- Arcs defined by
  - Radius and centre point
  - Radius and two points
  - Diameter
  - Three points
  - Centre point and point on circumference

Circles defined by  
Radius and centre point  
Radius and two points on diameter  
Three points  
Centre point and point on circumference

- ◇ *For arcs defined by radius and two points, the arc is drawn from the first point defined to the second point in the direction of the hand of the defined radius (ie positive-clockwise and negative anti-clockwise).*
- ◇ *For arcs defined by three points, the arc is drawn from the first point to the third point through the second point.*
- ◇ *For arcs defined by either radius and centre point or by diameter, secondary information is required defining the extent of the arc. This information may be either the start and end point or the start and end radial bearing.*

## Boxes

Rectangles or Boxes defined by:-  
Opposite corners  
Bottom left, bearing of LHS and length

## Frames and meshes

To aid size and positional judgements the framing of the drawing (option 821 in DRAW) and other related features may be invoked within ENHANCE. The drawing may also have a mesh superimposed to help in the positioning of information, particularly text. This is effectively a grid in drawing coordinates but the feature exists within IGMODE to position text by 'clamping' on to the mesh.

Features available:

- Add the drawing frame outline
- Add the drawing window outline
- Add drawing registration marks
- Mesh details defined by opposite corners and spacings

**Lines / polylines**

Lines defined by

Start and end point

Start point, bearing and length

Polyline defined by

Consecutive coordinate points

(May be open or closed polygons)

Horizontal line defined by

Start and end point

Start point and length

Vertical line defined by

Start and end point

Start point and length

**Text / polytext**

Text defined by

Character string and reference point(s)

Character string defined as

Single line of text

Multiple lines of text related to same reference point(s)

Reference for text defined by

Two points

Point and direction

Text may be

Copied

Moved

Replaced

Optionally boxed

Left / Right / Centre justified about its reference points

Top / Bottom / Centre justified about its reference points

Whilst the great flexibility of environment definition of text sizes etc allows a number of permutations for the placement of text, there are some commonly occurring combinations. These have been collected together within IGMODE, and are simulated by a macro LINETEXT in LINEMODE. They are:-

Automatic one line of text.

Automatic multiple lines of text (polytext).

Automatic one line of text is defined as a line of text together with 2 points. The text is centred between the defined points at the current character size.

Automatic polytext is defined as a line of text together with 1 point + bearing followed by subsequent lines of text automatically positioned on lines below the first.

**Macrosymbols and standard symbols**

Macro and standard symbols may be positioned on the drawing. This allows for the inclusion of specialised symbols such as north signs and company logos.

**Hatching**

Hatching may be used to provide an effective graphic identification for areas of special interest. This when referenced by a drawing key can simplify complex drawings.

Hatching may be defined by  
 Inside a boundary element  
 Between two elements  
 Between two lines

**Detailed description of minor options**

The minor options available in ENHANCE are:

<b>SELECTION</b>	Environment	Line pen type and colour	805
		Text pen type and colour	806
		Fill area characteristics	807
		Text chracteristics	808
		Line characteristics	810
		Objects	814/815/817
		Clipping	818/819
		Frames	821
		Define sheet	Define extent
	<b>DRAWING</b>	Annotation	Meshes
Lines and polylines			882
Text			883/884
Symbols		Macrosymbol	886
		Standard symbol	887
		Boxes	888
		Arcs and circles	889/890
Hatching		Inside a boundary	894
		Between two elenments	895
		Between two lines	896/897

## Access to major option ENHANCE

### Input

### Graphics

IGENLT.DAT, GEN 005, IGENHAT.DAT, ENH 001

Drawing options	ENHANCE options
DRAW - Working drawings	Arcs
DRAW - Contract drawings	Boxes
ENHANCE - Drawings	Circles
Add annotation	Frames and Meshes
CLIP - drawings	Lines / polylines
LAYOUT	Text / polytext
Drawing sheets	Macrosymbols
MACROSYMBOLS	Standard symbols
Create/amend/store	Hatching
VIEW	End ENHANCE
Prospective/photo	
VISUALISE	
Prepare EPIC data	
2DDXF	
DPF conversion to DXF	
NEWDPF - Select DPF	
NEWRPF - Select RPF	
REPORT	
Models/strings/points	

- ◇ *In ENHANCE there is no requirement to select a model as none of the options interact with the model file.*

### Linemode

Major option ENHANCE

Leave both model names blank, as none of the options interact with the model file.

### Global minor options

The global minor options 000, 017, 018, 900 and 999 may be used.

## Minor option 805, 806, 807, 808, 810, 814, 815, 817, 818, 819 and 821

Selection of drawing environment.

All these options are identical to those within major option DRAW and are described in the DRAW section of this chapter.

## Minor option 880 Define drawing sheets

If a drawing consists of several sheets the enhancing components that follow will be superimposed on one or all of the sheets.

### Input

### Graphics

This option is not available in graphics, as the sheet selection is interactive.

### Linemode

#### Minor option 880

- \* Field 1 Code ALL if all sheets are to be enhanced (default).
  - Field 4 Sheet number to be enhanced if only 1 sheet is to have enhancement applied to it.
- ◇ *An 880,ALL cannot be combined with any other 880 individual sheet requirement in a single ENHANCE.*

### Example

```
ENHANCE
880,ALL
883,2=LB,5=20,20,0.0
884,I001,&SHEE& of &TOTL&
884,I002,&TIME& &DATE&

ENHANCE
880,4=2
880,4=3
883,2=LB,5=20,20,0.0
884,D001,Annotate sheets 2 and 3 only
999
```

## Minor option 821, 881 Frames and meshes

### Input

### Graphics

<b>ENHANCE options</b>	<b>Frames and Meshes</b>	<b>Add drawing frame</b>
Arcs	Add drawing frame	Drawing frame selected
Boxes	Add drawing window	Frame label
Circles	Add registration marks	
<b>Frames and Meshes</b>	Add mesh (2 corners)	
Lines / polylines	Add mesh (increments)	
Text / polytext	End ENHANCE	
Macrosymbols		
Standard symbols		
Hatching		
End ENHANCE		

### IGENHAT.DAT, ENH 001, ENH 018, ENH 019

<b>ENHANCE options</b>	<b>Frames and Meshes</b>	<b>Add drawing window</b>
Arcs	Add drawing frame	Drawing window selected
Boxes	Add drawing window	Drawing window label
Circles	Add registration marks	
<b>Frames and Meshes</b>	Add mesh (2 corners)	
Lines / polylines	Add mesh (increments)	
Text / polytext	End ENHANCE	
Macrosymbols		
Standard symbols		
Hatching		
End ENHANCE		

**IGENHAT.DAT, ENH 001, ENH 018, ENH 020**

<b>ENHANCE options</b>	<b>Frames and Meshes</b>	<b>Add registration marks</b>
Arcs	Add drawing frame	Regist'n markers selected
Boxes	Add drawing window	Regist'n markers label
Circles	Add registration marks	
<b>Frames and Meshes</b>	Add mesh (2 corners)	
Lines / polylines	Add mesh (increments)	
Text / polytext	End ENHANCE	
Macrosymbols		
Standard symbols		
Hatching		
End ENHANCE		

**IGENHAT.DAT, ENH 001, ENH 018, ENH 021**

<b>ENHANCE options</b>	<b>Frames and Meshes</b>	<b>Add mesh (2 corners)</b>
Arcs	Add drawing frame	Mesh style selected
Boxes	Add drawing window	Mesh label
Circles	Add registration marks	X spacing interval
<b>Frames and Meshes</b>	Add mesh (2 corners)	Y spacing interval
Lines / polylines	Add mesh (increments)	1st corner X
Text / polytext	End ENHANCE	1st corner Y
Macrosymbols		2nd corner X
Standard symbols		2nd corner Y
Hatching		
End ENHANCE		



IGENHAT.DAT, ENH 001, ENH 018, ENH 022

ENHANCE options	Frames and Meshes	Add mesh (increments)
Arcs	Add drawing frame	Mesh style selected
Boxes	Add drawing window	Mesh label
Circles	Add registration marks	X spacing interval
Frames and Meshes	Add mesh (2 corners)	Y spacing interval
Lines / polylines	Add mesh (increments)	Bottom left X
Text / polytext	End ENHANCE	Bottom left Y
Macrosymbols		No. of X increments
Standard symbols		No. of Y increments
Hatching		
End ENHANCE		

IGENHAT.DAT, ENH 001, ENH 018, ENH 023

Linemode

Minor option 881 Superimpose a mesh

This option is mostly (if not always) used within interactive mode. It is only given here for completeness. Once positioned, the mesh is used (within IGMODE) to 'clamp' data to the nearest mesh point; and is invaluable for the simple alignment of lines of text and geometric entities. It is invariably used for construction of the drawing and once text etc is in position the mesh is deleted before producing a hard copy drawing.

**Full mesh**

Minor option 881

Field 3 Picture element label (optional).

**Mesh defined by opposite corners**

Minor option 881

Field 1 MSH1

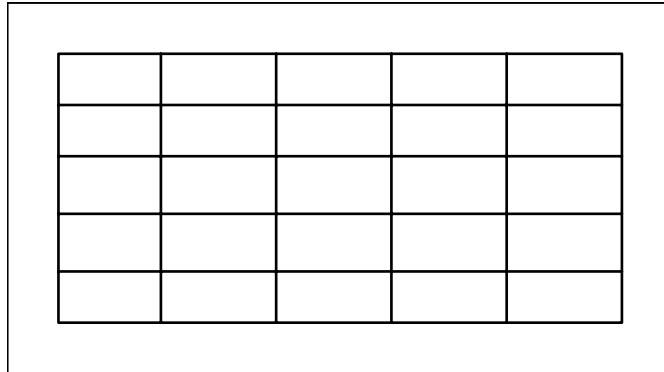
Field 3 Picture element label (optional).

Field 5 & 6 Coordinates of corner of mesh (drawing units).

Field 7 Horizontal spacing interval (default 1.0).

Field 8 & 9 Coordinates of opposite corner of mesh (drawing units).

Field 10 Vertical spacing interval (default 1.0).

**Example****Figure 3 - 168 Example mesh**

881,MSH1,5=20,10,2,30,15,1

**Mesh defined by corner and number of increments**

Minor option 881

Field 1 MSH2

Field 3 Picture element label (optional).

Field 5 & 6 Coordinates of bottom left point of mesh (drawing units).

Field 7 Horizontal spacing interval (default 1.0).

Field 8 Number of horizontal increments.

Field 9 Number of vertical increments.

Field 10 Vertical spacing interval (default 1.0).

**Example**

881,MSH2,5=20,10,2,5,5,1

Would produce the same drawing as Figure 3 - 168.

## Minor option 882 Lines / polylines

### Input

### Graphics

ENHANCE options	Lines / polylines	Start and end points
Arcs	Start and end points	Line label
Boxes	Point bearing and length	Start X
Circles	Polyline	Start Y
Frames and Meshes	Horizontal 2 points	End X
Lines / polylines	Pt & horizontal length	End Y
Text / polytext	Vertical 2 points	
Macrosymbols	Point & vertical length	
Standard symbols	End ENHANCE	
Hatching		
End ENHANCE		

IGENHAT.DAT, ENH 001, ENH 024, ENH 025

ENHANCE options	Lines / Polylines	Point bearing and length
Arcs	Start and end points	Line label
Boxes	Point bearing and length	Start X
Circles	Polyline	Start Y
Frames and Meshes	Horizontal 2 points	Bearing
Lines / polylines	Pt & horizontal length	Length
Text / polytext	Vertical 2 points	
Macrosymbols	Point & vertical length	
Standard symbols	End ENHANCE	
Hatching		
End ENHANCE		

IGENHAT.DAT, ENH 001, ENH 024, ENH 026

ENHANCE options	Lines / polylines	Polyline
Arcs	Start and end points	Line label
Boxes	Point bearing and length	CLOS/LAST/blank (T)
Circles	Polyline	Start X
Frames and Meshes	Horizontal 2 points	Start Y
Lines / polylines	Pt & horizontal length	End X
Text / polytext	Vertical 2 points	End Y
Macrosymbols	Point & vertical length	
Standard symbols	End ENHANCE	
Hatching		
End ENHANCE		

IGENHAT.DAT, ENH 001, ENH 024, ENH 027

- ◇ *You will be prompted for additional polyline points until the toggle CLOS/LAST is switched to indicate otherwise. Select CLOS if you wish to close a polygon. Select LAST this is the last of a polyline series.*

ENHANCE options	Lines / polylines	Horizontal 2 points
Arcs	Start and end points	Line label
Boxes	Point bearing and length	Line style selected
Circles	Polyline	Start X
Frames and Meshes	Horizontal 2 points	Start Y
Lines / polylines	Pt & horizontal length	End X
Text / polytext	Vertical 2 points	End Y
Macrosymbols	Point & vertical length	
Standard symbols	End ENHANCE	
Hatching		
End ENHANCE		

**IGENHAT.DAT, ENH 001, ENH 024, ENH 029**

ENHANCE options	Lines / polylines	Pt & horizontal length
Arcs	Start and end points	Line label
Boxes	Point bearing and length	Line style selected
Circles	Polyline	Start X
Frames and Meshes	Horizontal 2 points	Start Y
Lines / polylines	Pt & horizontal length	Length
Text / polytext	Vertical 2 points	
Macrosymbols	Point & vertical length	
Standard symbols	End ENHANCE	
Hatching		
End ENHANCE		

**IGENHAT.DAT, ENH 001, ENH 024, ENH 030**

ENHANCE options	Lines / polylines	Vertical 2 points
Arcs	Start and end points	Line label
Boxes	Point bearing and length	Line style selected
Circles	Polyline	Start X
Frames and Meshes	Horizontal 2 points	Start Y
Lines / polylines	Pt & horizontal length	End X
Text / polytext	Vertical 2 points	End Y
Macrosymbols	Point & vertical length	
Standard symbols	End ENHANCE	
Hatching		
End ENHANCE		

IGENHAT.DAT, ENH 001, ENH 024, ENH 031

ENHANCE options	Lines / polylines	Point & vertical length
Arcs	Start and end points	Line label
Boxes	Point bearing and length	Line style selected
Circles	Polyline	Start X
Frames and Meshes	Horizontal 2 points	Start Y
Lines / polylines	Pt & horizontal length	Length
Text / polytext	Vertical 2 points	
Macrosymbols	Point & vertical length	
Standard symbols	End ENHANCE	
Hatching		
End ENHANCE		

IGENHAT.DAT, ENH 001, ENH 024, ENH 032

Linemode

Various alternatives are available.

- (i) Draw a line defined by 2 coordinate points.
- (ii) Draw a 'polyline' or a series of line segments defined by successive coordinates.
- (iii) Draw a line defined by a coordinate point, bearing and length of line.

**Draw a line defined by 2 coordinate points.**

Minor option 882

Field 3      Picture element label (optional).

- \* Field 5 & 6    First coordinate pair (drawing units).
- \* Field 8 & 9    Second coordinate pair (drawing units).

Example

882,5=10,10,8=20,20

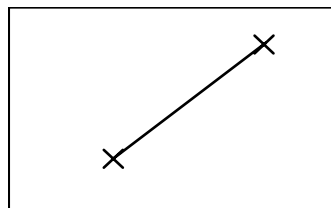


Figure 3 - 169 Polyline

**Draw a polyline defined by successive coordinate pairs.**

Minor option 882

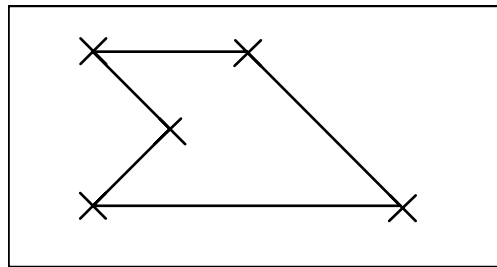
- Field 1 Code CLOS if this record is the last of a polyline series and it is wished to close the polygon.  
Code LAST if this is the last of a polyline series.
- Field 3 Picture element label (must be coded).
- \* Field 5 & 6 Coordinate pair (drawing units).
- \* Field 8 & 9 Next coordinate pair (drawing units).

Successive points will be joined until:-

- a new minor option is encountered.
- or a different picture element label is defined (field 3).
- or 'CLOS' or 'LAST' is coded in field 1.

**Example**

```
882,5=10,10,8=15,15
882,5=10,20,8=20,20
882,CLOS,5=30,10
```



**Figure 3 - 170 Polylines forming closed polygon**

**Define line by coordinate and bearing**

Minor option 882

- Field 3 Picture element label (optional).
- \* Field 5 & 6 Point coordinates (drawing units).
- Field 7 Bearing of line relative to left hand side of drawing (using current input angle definition style).
- \* Field 8 Length of line in drawing units.

Example

017,DEGR  
882,5=10,10,45.0,10

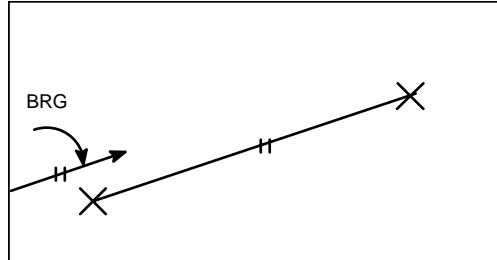


Figure 3 - 171 Line by coordinate and bearing

Minor option 883, 884 Text / polytext

Input

Graphics

ENHANCE options	Text / polytext	Automatic one line
Arcs	Automatic one line	Text
Boxes	Automatic polytext	Text object label
Circles	Start and end points	Box style (T)
Frames and Meshes	Ref. point and bearing	Text justification (T)
Lines / polylines	Polytext from file	Start X
Text / polytext	End ENHANCE	Start Y
Macrosymbols		End X
Standard symbols		End Y
Hatching		
End ENHANCE		



IGENHAT.DAT, ENH 001, ENH 033, ENH 034

ENHANCE options	Text / polytext	Automatic polytext
Arcs	Automatic one line	Text
Boxes	Automatic polytext	Innn/Dnnn
Circles	Start and end points	Text object label
Frames and Meshes	Ref. point and bearing	Box type (T)
Lines / polylines	Polytext from file	Text justification (T)
Text / polytext	End ENHANCE	Bearing
Macrosymbols		Reference point X
Standard symbols		Reference point Y
Hatching		
End ENHANCE		

IGENHAT.DAT, ENH 001, ENH 033, ENH 035

- ◇ *When you have completed the information in the Automatic polytext menu, proceed will cause display of a second menu. This second menu allows you to enter the text to be added to the drawing.*

ENHANCE options	Text / polytext	Start and end points
Arcs	Automatic one line	Text
Boxes	Automatic polytext	Innn/Dnnn
Circles	Start and end points	Text object label
Frames and Meshes	Ref. point and bearing	Box type (T)
Lines / polylines	Polytext from file	Text justification (T)
Text / polytext	End ENHANCE	Start X
Macrosymbols		Start Y
Standard symbols		End X
Hatching		End Y
End ENHANCE		

IGENHAT.DAT, ENH 001, ENH 033, ENH 037

ENHANCE options	Text / polytext	Ref. point and bearing
Arcs	Automatic one line	Text
Boxes	Automatic polytext	Inn/Dnnn
Circles	Start and end points	Text object label
Frames and Meshes	Ref. point and bearing	Box type (T)
Lines / polylines	Polytext from file	Text justification (T)
Text / polytext	End ENHANCE	Bearing
Macrosymbols		Reference point X
Standard symbols		Reference point Y
Hatching		
End ENHANCE		

IGENHAT.DAT, ENH 001, ENH 033, ENH 038

ENHANCE options	Text / polytext	Polytext from file
Arcs	Automatic one line	File name
Boxes	Automatic polytext	
Circles	Start and end points	
Frames and Meshes	Ref. point and bearing	
Lines / polylines	Polytext from file	
Text / polytext	End ENHANCE	
Macrosymbols		
Standard symbols		
Hatching		
End ENHANCE		

IGENHAT.DAT, ENH 001, ENH 035, ENH 039

- ◇ *When you have supplied the text filename, Proceed will cause the display of a second menu. This second menu allows you to position the text.*
- ◇ *'Polytext from file' is available in IGMODE only.*
- ◇ *The default file extension is '.dat'.*

Polytext from file
File name
Text object label
Box type (T)
Text justification (T)
Bearing of left hand side
Origin location (T)
Origin position X
Origin position Y
Display box only
Display box and text

**IGENHAT.DAT, ENH 040****Linemode**

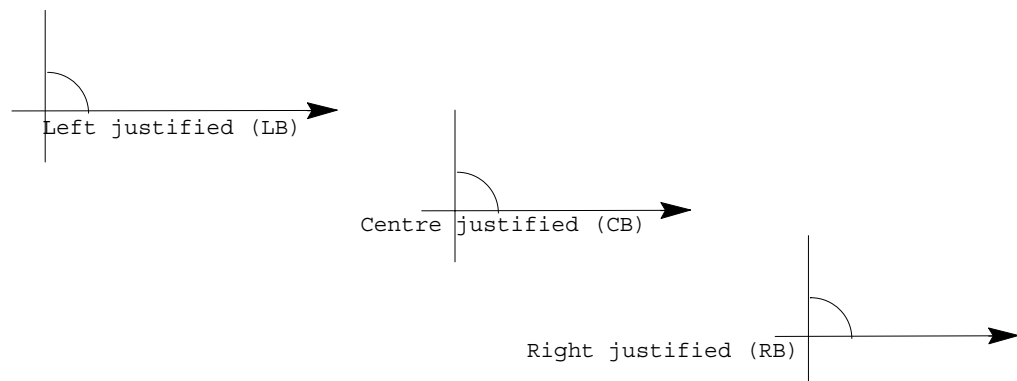
Draw line(s) of alphanumeric text.

883 defines the location.

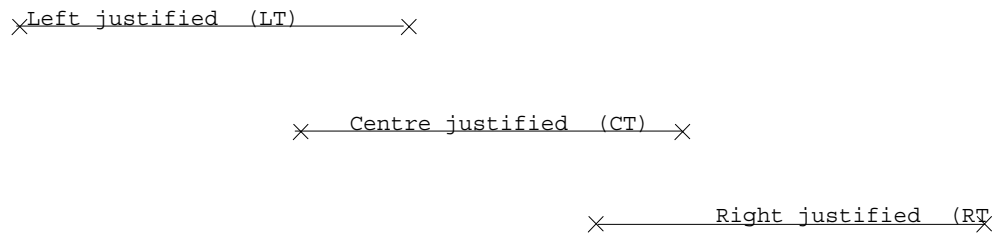
884 defines the alphanumeric text.

Each line of text is drawn relative to either one or two reference points which are defined by the coordinate position and bearing, or two coordinate positions.

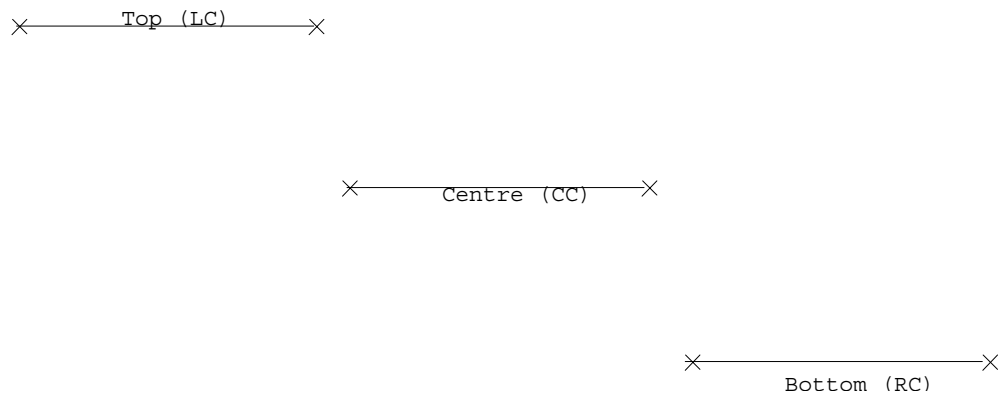
Text may be justified relative to the reference points as shown in Figure 3 - 172, Figure 3 - 173 and Figure 3 - 174. Note the characters in brackets show the Text justification toggles setting used. The angle of the text is dictated by either the bearing defined, or by positioning the text along the line between the two reference points.



**Figure 3 - 172 Text - Reference point and bearing**



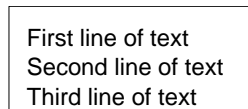
**Figure 3 - 173 Text - start and end points**



**Figure 3 - 174 Text - vertical justification**

The location defined by option 883 is used to position the text as specified on the 884 option. Further lines of text may be added to the “current” location by specifying above (I) or below (D) plus an incrementing number eg I002 would locate the text two line spacings above the current text location as defined on 883. See minor option 808 for full details.

The text may also be outlined and the box outline is drawn once the last line of text is complete. The extent of the box outline is determined from a combination of the character dimensions (height, width and spacing), the number of characters in the longest line and the number of lines in the block. An allowance of 0.5 x character width is made to either side.



**Figure 3 - 175 Text - boxed**

## Input

Define the location of the text - 883

Define the text characters - 884

A text reference point is defined and all dimensions are relative to it. A second reference point is also occasionally required to define the angle of the text or the justification.

### Minor option 883

Field 1 Outlining of text (optional)

Column 1:

B draw a complete box surrounding the area.

L underline the text (see column 2).

Column 2:

B underline the bottom of text.

T draw a line at the top of the text.

L draw a line at the left of the text.

R draw a line at the right of the text.  
(default - no outlining)

Field 2 Text positioning relative the text reference point(s) (optional)

Column 1:

L left justified.

R right justified.

C centre justified.

Column 2:

T top justified.

B bottom justified.

C centre justified.  
(default - LT)

Field 3 Picture object label (optional)

\* Field 5 & 6 Coordinates of text reference point (drawing units)

Field 7 Angle of text relative to LHS.  
(using current input angle definition)  
(a value of 0.0 would give horizontal text)  
or

Field 8 & 9 Coordinates of second reference point.

### Minor option 884

Field 1 Increment or decrease from the base defined by 883.

Column 1:

I increase from base.

D decrease from base.

Column 2, 3, 4:

an integer number (right justified) between 000 and 99 (default D000)

Field 2 - 10 Characters defining line of text.

The ampersand character (&) is not allowed in normal text.

Alternatively, a keyword surrounded by ampersand characters may be entered as follows:

SHEE Current sheet number

TOTL Total number of sheets in the DPF

TIME Time that the enhancement is added, eg, 17.05:43

DATE Date that the enhancement is added in UK format, eg, 21/02/92

DTUS Date that the enhancement is added in US format, eg, 02/21/92

HSCA Horizontal scale

VSCA Vertical scale

The system automatically supplies the correct value for each specified keyword and the value is drawn on the screen.

- ◇ *The automatic annotation of horizontal and vertical drawing scales is appropriate where dpfs have been automatically scaled to fit a specified sheet size.*
- ◇ *Any of these keywords may be substituted directly into ENHANCE macros such as FRAMEA1 and FRAMEA0 to automatically annotate the required data, for example &HSCA& will give horizontal scale.*
- ◇ *Horizontal and vertical scales will be ignored on composite drawings.*

### Example 1

```
883,5=22,24
884,COORDINATE SCHEDULE
884,D001,Stn EASTING NORTHING HEIGHT DESCRIPTION
884,D002, 1 166.195 100.0 54.311 Disk Mark
```

### Example 2

The following example gives a running page count for each page in a DPF:

```
883,5=78,10
884,Sheet &SHEE& of &TOTL&
```

### Example 3

The following example shows the addition of both horizontal and vertical scales:

```
DRAW,DAM GENERAL SECTIONS,DAM DESIGN
800,4=1,3
803,ACRS,PAGE,NOTR
803,7=50,10=10
803,7=50,10=25
803,7=100,10=25
```

```

803,7=100,10=50
804,CROS,ADD,M001
826,G
999
ENHANCE
806,PINK
883,5=35,10
884,HORINTAL 1:&HSCA&
883,5=35,6
884,VERTICAL 1:&VSCA&
999

```

This uses an alternative style for presenting the scales:

```

ENHANCE
806,PINK
883,5=35,10
884,Scale 1:&HSCA&/&VSCA&
999

```

### Minor option 886 Macrosymbols

This option may be used to draw a macrosymbol, such as a north point or company logo.

#### Input

#### Graphics

ENHANCE options	Macrosymbols
Arcs	Macroname
Boxes	Label
Circles	Width
Frames and Meshes	Height
Lines / polylines	Bearing
Text / polytext	X position
<b>Macrosymbols</b>	Y position
Standard symbols	
Hatching	
End ENHANCE	

IGENHAT.DAT, ENH 001, ENH 041

Linemode

Minor option 886

- Field 1 & 2 Macroname.
- Field 3 Picture element label (optional).
- Field 4 Drawn width of the symbol (drawing units).
- \* Field 5 & 6 Coordinate point where symbol is to be drawn (drawing units).
- \* Field 7 Drawn depth of the symbol (drawing units).
- \* Field 10 Bearing of macrosymbol relative to the left hand side of the page.

Minor option 887 Standard symbols

This option may be used to draw a standard symbol. The standard symbols are illustrated in minor option 863.

Input

Graphics

ENHANCE options	Standard symbols
Arcs	Symbol number
Boxes	Label
Circles	Width
Frames and Meshes	Bearing
Lines / polylines	X position
Text / polytext	Y position
Macrosymbols	
Standard symbols	
Hatching	
End ENHANCE	

IGENHAT.DAT, ENH 001, ENH 042

Linemode

Minor option 887

- \* Field 2 Symbol number.
- Field 3 Picture element label (optional).
- Field 4 Drawn width of the symbol (drawing units).
- \* Field 5 & 6 Coordinate point where symbol is to be drawn (drawing units).



Field 10      Bearing of the symbol relative to the left hand side of the page.

## Minor option 888    Boxes

This option may be used to draw boxes (rectangles). Two methods are available -

- by opposite corners
- by the length and bearing of the left hand side.

### Input

### Graphics

ENHANCE options	Boxes	Opposite corners
Arcs	Opposite corners	Box label
Boxes	Length and bearing of LHS	1st corner X
Circles	End ENHANCE	1st corner Y
Frames and Meshes		2nd corner X
Lines / polylines		2nd corner Y
Text / polytext		
Macrosymbols		
Standard symbols		
Hatching		
End ENHANCE		

IGENHAT.DAT, ENH 001, ENH 009, ENH 010

ENHANCE options	Boxes	Length and bearing of LHS
Arcs	Opposite corners	Box label
Boxes	Length and bearing of LHS	Bottom left X
Circles	End ENHANCE	Bottom left Y
Frames and Meshes		Bearing LHS
Lines / polylines		Width
Text / polytext		Height
Macrosymbols		
Standard symbols		
Hatching		
End ENHANCE		

IGENHAT.DAT, ENH 001, ENH 009, ENH 011

Linemode

Minor option 888

**Define rectangle by opposite corners**

Field 3 Picture element label (optional)

\* Field 5 & 6 Coordinates of first corner of rectangle.

Field 8 & 9 Coordinates of second corner of rectangle.

**Define rectangle by lengths and bearing of the left hand side**

Field 3 Picture element label (optional).

\* Field 5 & 6 Coordinates of bottom left corner of rectangle (drawing units).

\* Field 7 Bearing of the left hand side of the rectangle measured clockwise from the left hand side of the drawing.

\* Field 8 Length of the base of the rectangle.

\* Field 9 Length of the side of the rectangle.

**Minor option 889 Circles**

The methods available to define the circle are -

- Centre and through point
- Radius and centre point
- Radius and through 2 points
- Through 2 points on diameter
- Through 3 points.

Input

Graphics

ENHANCE options	Circles	Centre and through point
Arcs	Centre and through point	Circle definition method
Boxes	Radius and centre point	Circle label
Circles	Radius and through 2 pts	X centre
Frames and Meshes	Through 2 pts on diameter	Y centre
Lines / polylines	Through 3 points	X circumference point
Text / polytext	End ENHANCE	Y circumference point
Macrosymbols		
Standard symbols		
Hatching		
End ENHANCE		

IGENHAT.DAT, ENH 001, ENH 012, ENH 013

ENHANCE options	Circles	Radius and centre point
Arcs	Centre and through point	Circle definition method
Boxes	Radius and centre point	Circle label
Circles	Radius and through 2 pts	X centre
Frames and Meshes	Through 2 pts on diameter	Y centre
Lines / polylines	Through 3 points	Radius
Text / polytext	End ENHANCE	
Macrosymbols		
Standard symbols		
Hatching		
End ENHANCE		

**IGENHAT.DAT, ENH 001, ENH 012, ENH 014**

<b>ENHANCE options</b>	<b>Circles</b>	<b>Radius and through 2 pts</b>
Arcs	Centre and through point	Circle definition method
Boxes	Radius and centre point	Circle label
<b>Circles</b>	<b>Radius and through 2 pts</b>	1st Point X
Frames and Meshes	Through 2 pts on diameter	1st Point Y
Lines / polylines	Through 3 points	2nd Point X
Text / polytext	End ENHANCE	2nd Point Y
Macrosymbols		Radius
Standard symbols		
Hatching		
End ENHANCE		

**IGENHAT.DAT, ENH 001, ENH 012, ENH 015**

<b>ENHANCE options</b>	<b>Circles</b>	<b>Through 2 pts on diameter</b>
Arcs	Centre and through point	Circle definition method
Boxes	Radius and centre point	Circle label
<b>Circles</b>	<b>Radius and through 2 pts</b>	1st Point X
Frames and Meshes	Through 2 pts on diameter	1st Point Y
Lines / polylines	Through 3 points	2nd Point X
Text / polytext	End ENHANCE	2nd Point Y
Macrosymbols		
Standard symbols		
Hatching		
End ENHANCE		

IGENHAT.DAT, ENH 001, ENH 012, ENH 016

ENHANCE options	Circles	Through 3 points
Arcs	Centre and through point	Circle definition method
Boxes	Radius and centre point	Circle label
Circles	Radius and through 2 pts	1st Point X
Frames and Meshes	Through 2 pts on diameter	1st Point Y
Lines / polylines	Through 3 points	2nd Point X
Text / polytext	End ENHANCE	2nd Point X
Macrosymbols		3rd point X
Standard symbols		3rd point Y
Hatching		
End ENHANCE		

IGENHAT.DAT, ENH 001, ENH 012, ENH 017

Linemode

**Draw a circle**

Minor option 889

- |                |  |
|----------------|--|
| Field 1        | Circle type indicator  |
|                | CIRC            centre and radius  |
|                | CIRP            centre and point on circumference.                                       |
|                | CIR2            two points and radius.   |
|                | CIRD            two points on diameter   |
|                | CIR3            three points.  |
| Field 3        | Picture element label (optional).  |
| * Field 5 & 6  | Coordinates of centre (CIRC and CIRP)<br>Coordinates of first point (CIR2; CIRD; CIR3)   |
| * Field 7      | Radius (CIRC and CIR2)   |
| * Field 7 & 8  | Coordinates of second point (CIR3)   |
| * Field 8 & 9  | Coordinates of point on circumference (CIRP)<br>Coordinates of second point (CIR2; CIRD) |
| * Field 9 & 10 | Coordinates of third point (CIR3)  |

**Minor option 889, 890    Arcs**

The methods available to define the arc are -

- Centre and through point
- Radius and centre point
- Radius and through 2 points

- Through 2 points on diameter
- Through 3 points.

Input

Graphics

ENHANCE options	Arcs	Centre and through point
Arcs	Centre and through point	Arc definition method
Boxes	Radius and centre point	Arc label
Circles	Radius and through 2 pts	X centre
Frames and Meshes	Through 2 pts on diameter	Y centre
Lines / polylines	Through 3 points	C circumference point
Text / polytext	End ENHANCE	Y circumference point
Macrosymbols		
Standard symbols		
Hatching		
End ENHANCE		

IGENHAT.DAT, ENH 001, ENH 002, ENH 003

ENHANCE options	Arcs	Radius and centre point
Arcs	Centre and through point	Arc definition method
Boxes	Radius and centre point	Arc label
Circles	Radius and through 2 pts	X centre
Frames and Meshes	Through 2 pts on diameter	Y centre
Lines / polylines	Through 3 points	Radius
Text / polytext	End ENHANCE	
Macrosymbols		
Standard symbols		
Hatching		
End ENHANCE		

IGENHAT.DAT, ENH 001, ENH 002, ENH 005

ENHANCE options	Arcs	Radius and through 2 pts
Arcs	Centre and through point	Arc definition method
Boxes	Radius and centre point	Arc label
Circles	Radius and through 2 pts	1st Point X
Frames and Meshes	Through 2 pts on diameter	1st Point Y
Lines / polylines	Through 3 points	2nd Point X
Text / polytext	End ENHANCE	2nd Point Y
Macrosymbols		Radius
Standard symbols		
Hatching		
End ENHANCE		

IGENHAT.DAT, ENH 001, ENH 002, ENH 006

ENHANCE options	Arcs	Through 2 pts on diameter
Arcs	Centre and through point	Arc definition method
Boxes	Radius and centre point	Arc label
Circles	Radius and through 2 pts	1st Point X
Frames and Meshes	Through 2 pts on diameter	1st Point Y
Lines / polylines	Through 3 points	2nd Point X
Text / polytext	End ENHANCE	2nd Point Y
Macrosymbols		
Standard symbols		
Hatching		
End ENHANCE		

IGENHAT.DAT, ENH 001, ENH 002, ENH 007

ENHANCE options	Arcs	Through 3 points
Arcs	Centre and through point	Arc definition method
Boxes	Radius and centre point	Arc label
Circles	Radius and through 2 pts	1st Point X
Frames and Meshes	Through 2 pts on diameter	1st Point Y
Lines / polylines	Through 3 points	2nd Point X
Text / polytext	End ENHANCE	2nd Point Y
Macrosymbols		3rd Point X
Standard symbols		3rd Point Y
Hatching		
End ENHANCE		

IGENHAT.DAT, ENH 001, ENH 002, ENH 008

Arc - define end points
Start point X
Start point Y
Or start bearing
End point X
End point Y
Or end bearing

IGENHAT.DAT, ENH004

- ◇ *Minor option 889 will be followed by minor option 890 to define the extent of the arc, alternatively defaults may be applied.*

Linemode

Minor option 889

Field 1      ARCC  
                  ARCP  
                  ARC2  
                  ARCD  
                  ARC3



- Field 3      Picture element label (optional).
- \* Field 5 & 6    Coordinates of centre (ARCC and ARCP)  
                  Coordinates of first point (ARC2; ARCD; ARC3)
- \* Field 7        Radius (ARCC and ARC2)
- \* Field 7 & 8    Coordinates of second point (ARC3)
- \* Field 8 & 9    Coordinates of point on circumference (ARCP)  
                  Coordinates of second point (ARC2; ARCD)
- \* Field 9 & 10   Coordinates of third point (ARC3)

**Minor option 890**

Field 5 & 6    Start point coordinates.  
                  or

Field 7        Bearing of start of arc (drawn from centre).

Field 8 & 9    End point coordinates.  
                  or

Field 10      Bearing of end of arc (drawn from centre).

For arcs defined by radius and two points, the arc is drawn from the first point defined to the second point in the direction of the hand defined by the radius (ie positive - clockwise and negative - anticlockwise). If no option 890 is given the coordinates defined on option 889 are used.

For arcs defined by three points, the arc is drawn from the first to the third point through the second point.

For arcs defined by either radius and centre point, or by diameter the secondary information defined by 890 must be provided.

## Minor option 894 Hatch inside a boundary element

### Input

### Graphics

<b>ENHANCE options</b>	<b>Hatching</b>	<b>Inside a boundary element</b>
Arcs	Inside a boundary element	Label of boundary element
Boxes	Between two elements	Enclose hatching (T)
Circles	Between two lines	
Frames and Meshes	End ENHANCE	
Lines / polylines		
Text / polytext		
Macrosymbols		
Standard symbols		
Hatching		
End ENHANCE		

IGENHAT.DAT, ENH 001, ENH 043, ENH 044

### Linemode

#### Minor option 894

Field 1 Boundary element label

Field 7 Boundary indicator

1.0 draw boundary

-1.0 do not draw boundary

## Minor option 895 Hatch between two elements

### Input

### Graphics

IGENHAT.DAT, ENH 001, ENH 043, ENH 045

ENHANCE options	Hatching	Between two elements
Arcs	Inside a boundary element	First element label
Boxes	Between two elements	Hatching element label
Circles	Between two lines	New element label
Frames and Meshes	End ENHANCE	Enclose hatching (T)
Lines / polylines		
Text / polytext		
Macrosymbols		
Standard symbols		
Hatching		
End ENHANCE		

### Linemode

#### Minor option 895

Field 1	First element label
Field 3	Hatching label (optional)
Field 4	Hatching interval (drawing units)
Field 7	Boundary indicator
	1.0 draw boundary
	-1.0 do not draw boundary

## Minor option 896, 897 Hatch between two lines

### Input

### Graphics

IGENHAT.DAT, ENH 001, ENH 043, ENH 046

<b>ENHANCE options</b>	<b>Hatching</b>	<b>Between two lines</b>
Arcs	Inside a boundary element	Hatching element label
Boxes	Between two elements	Hatching interval
Circles	<b>Between two lines</b>	Line 1 X coord 1
Frames and Meshes	End ENHANCE	Y coord 1
Lines / polylines		Line 1 X coord 2
Text / polytext		Y coord 2
Macrosymbols		Enclose hatching (T)
Standard symbols		
<b>Hatching</b>		
End ENHANCE		

IGENHAT.DAT, ENH 047

<b>Between two lines</b>
Line 2 X coord 1
Y coord 1
Line 2 X coord 2
Y coord 2

## Linemode

Details of first line and hatching details - 896

### Minor option 896

Field 3 Hatching label (optional)

Field 4 Hatching interval (drawing units)

Field 5 & 6 Start of line 1 (drawing units)

Field 7 Boundary indicator

1.0 draw boundary

-1.0 do not draw boundary

Field 8 & 9 End of line 1 (drawing coordinates)

Details of second line - 897

### Minor option 897

Field 5 & 6 Start of line 2 (drawing coordinates)

Field 8 & 9 End of line 2 (drawing coordinates)

## Minor option 899 Report on the installation defaults

This option may be run from within either major option DRAW or ENHANCE. The values attributed by the installation to specific variables may be listed.

## Input data

### Minor option 899

No data fields are necessary.

## Example

```
DRAW      SDG
899
800 SHEET DEFINITION
      Length Max.Len.  Width.  Max.Wid.  X Factor  Y Factor  Type
      84.10  400.00    59.40   400.00    1.00     1.00     0
802 SHEET LAYOUT
      Margin Size:  5.000
803 PAGING DEFINITION
      Paging: NOPA  Truncation: TRUN
805 PEN FOR LINES
      Pen colour:  BLACK  Pen type:  BIRO  Pen Size:  0.300
806 PEN FOR TEXT
      Pen colour:  BLACK  Pen type:  BIRO  Pen Size:  0.300
808 TEXT CHARACTERISTICS
      Height H/WRatio  Spacing  Thick.  Slant  Lin.Spac  Font Type Styl D.Ps
      0.180    1.000    0.000    0.100    0.000    0.500     N     3
821 FRAMES
      Frame type:  0
822 GRIDS
      X Tick:  1.000  Y Tick:  1.000  Type:  0  Symbol:  NORTHING
825 LINE DETAILS
      Pip.Len.  Cont.Int.  Chmk.Int  Sym.Prop  PSN.Int.  Labels
```

```
      0.100      10.000      100.00      1.000      1      0
860 Pip Size:   0.100
861 Macro Symbol Length:  0.500
863 Standard Symbol Proportion:  1.000
865 Text Offset:  0.500 P.S.N. Marking Interval:  1
866 Text Offset:  0.500 Pip Size:  0.100 Chainage Marking Int.:  100.000
867 Text Offset: -0.500 Pip Size:  0.100 Chainage Marking Int.:  100.000
868 Text Offset:  0.500
869 Text Offset:  0.500
870 Hatch Spacing: 0.250 Hatch Angle:  0.000 DecDegs
887 Standard Symbol Proportion:  1.000
889 Circle Angular Increment:      10.000 DecDegs
999
OUTPUT
```

## Major option CLIP

Major option CLIP is used to remove superfluous information from designated areas of a DPF. The clipping process prepares a high quality drawing with annotation, macrosymbol and cadastral symbol information clearly displayed and free from overdrawing by other elements.

Annotation and symbols created using major options DRAW and ENHANCE may be designated as 'clip polygons' before clipping is carried out. During clipping, all erasable information is removed from within the boundary of a clip polygon. For example, boxes and circles created with ENHANCE and designated as clip polygons will have all erasable information removed from inside them. In the same way, individual text items can be designated as clip polygons to remove unwanted information.

Elements are designated as clip polygons by minor option 819, 'Set clip parameters'. This may also be accessed in IGMODE from the Envir button in the static menu area.

You may wish to retain some information which intersects the boundary of a clip polygon. If this is the case, you can set the clip status of the element(s) to permanent using minor option 818, 'Set clip status'. This is also accessed in IGMODE from the Envir button in the static menu area.

When creating a macrosymbol, individual parts of the macrosymbol may be drawn as 'impermeable'. This means that if a macrosymbol is designated as a clip polygon, any erasable elements are removed from within the impermeable boundary during clipping.

Major option CLIP creates a clipped copy of a DPF which can only be displayed or plotted, ie, once a DPF has been clipped, there can be no further information added from the model file.

For further details of macrosymbol creation and drawing, refer to Chapter 13, 'Macrosymbols and macrolines for drawing' and 'Major option MACROSYMBOL'.

For further details of permanent and erasable elements, refer to DRAW minor option 818, 'Set clip status'.

For further details of clip polygons, refer to DRAW minor option 819, 'Set clip parameters'.

◇ *For a definition of the terms 'item' and 'element', refer to Chapter 2, 'Models and the DPF'.*

### Input

### Graphics

On entry to major option CLIP, all the elements in the current DPF are redrawn in two colours and two styles:

Cyan	Normal elements
Yellow	Clip polygons

Solid Permanent elements  
Dashed Erasable elements

This allows you to see the elements which will be removed by the clipping process.

IGGENLT.DAT, GEN005, GEN035

Drawing option	Clipping options
DRAW - Working drawings	Add clipping polygon(s)
DRAW - Contract drawings	Delete clipping polygon(s)
ENHANCE - Drawings	Polygon(s) from (T)
Add annotation	
CLIP - drawings	Change element clip status
LAYOUT	
Drawing sheets	Create clipped drawing
MACROSYMBOLS	
Create/amend/store	
VIEW	
Prospective/photo	
VISUALISE	
Prepare EPIC data	
ZDDXF	
DPF conversion to DXF	
NEWDPF - Select DPF	
NEWRPF - Select RPF	
REPORT	
Models/strings/points	

**Add clipping polygon(s)** allows you to select an existing element or item and nominate it as a clip polygon. When selected, the element changes colour from cyan to yellow.

**Delete clipping polygon(s)** allows you to select a clip polygon so that it reverts to being a normal element. When selected, the polygon changes colour from yellow to cyan.

**Polygon(s) from** is a toggle which may be set to 'Element' or 'Item'. 'Element' allows you to create clip polygons from every item of annotation along an element. 'Item' allows you to create a clip polygon from an individual item on an element.

For example, if you want to create polygons around every textual item along a string except one, toggle 'Polygons from' to 'Element'. Select 'Add clipping polygons' followed by the string. Then toggle 'Polygons from' to 'Item', select 'Delete clipping polygons' followed by the string and the item to remain as a normal element. The line colour of the selected item will revert to cyan.

**Change element clip status** allows you to change the status of an element from erasable to permanent or vice versa.

When selected, an erasable element will change line style from dashed to solid and a permanent element will change from solid to dashed.

A permanent element is not erased if it is intersected by a clip polygon.



An erasable element is fully or partially erased if it is intersected by a clip polygon. Only those portions of the element which lie within the clip polygon are erased.

**Create clipped drawing** creates a clipped copy of the current DPF. The name of the clipped DPF is <filename>\_clp.dpf, where <filename> is the first four characters of the original DPF name.

Select Proceed to accept the clipped DPF, or Quit to return to the preview stage and make any modifications required.

#### Linemode

Major option CLIP

No field data is required.

A clipped copy of the current DPF is created.

### Example 1

The following diagrams show a DPF before and after clipping. The following main points are illustrated by the diagrams:

- Text annotation boxes have been nominated as clip polygons so that elements intersecting the boxes are clipped.
- Cadastral symbols have been nominated as clip polygons so that elements intersecting the symbols are clipped.
- The macrosymbol circle used as part of the vertical intersection point symbol is set to impermeable, so that a clip polygon is automatically created.

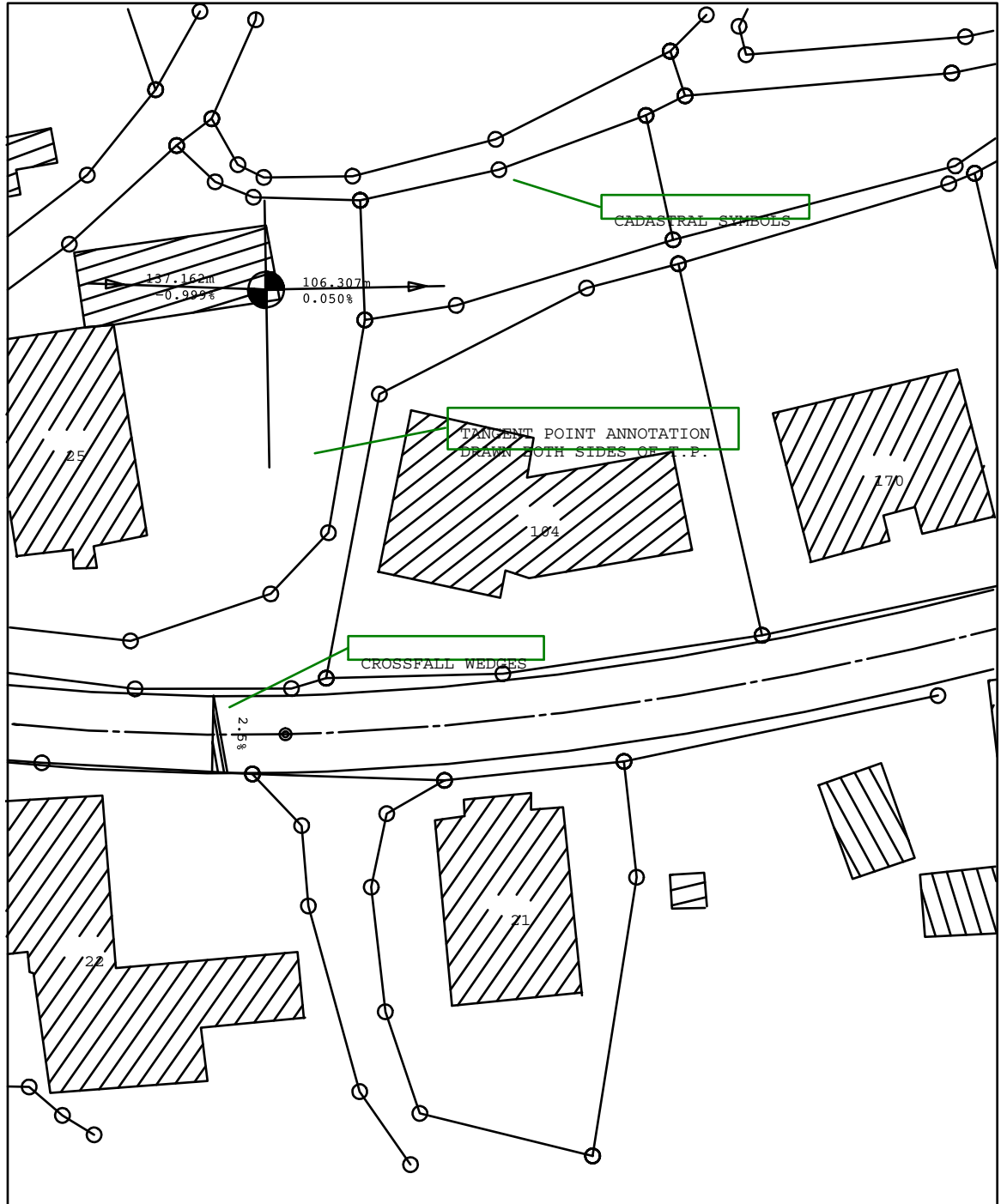


Figure 3 - 176 DPF before clipping

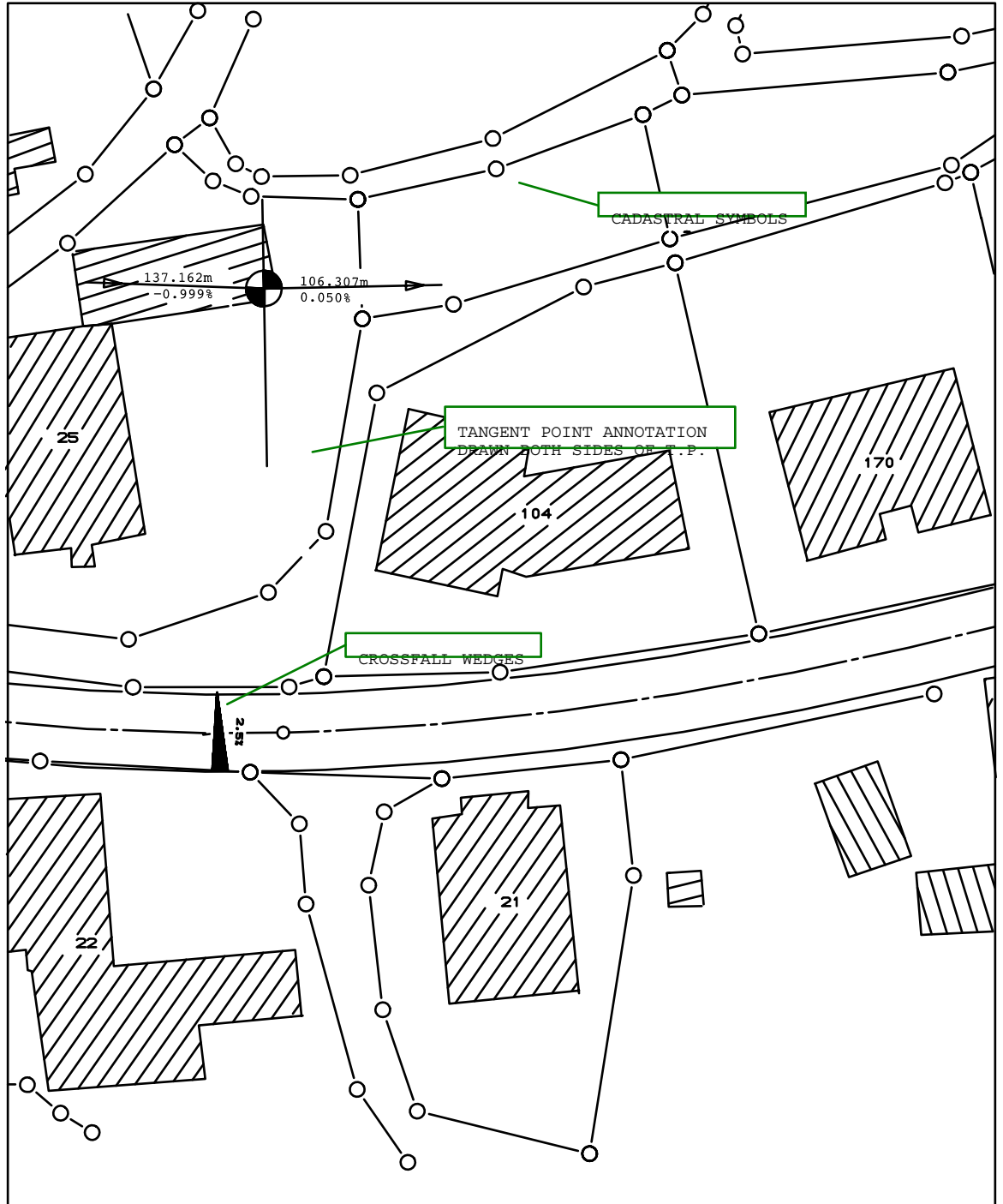


Figure 3 - 177 DPF after clipping

Example 2

This example illustrates the behaviour of permanent and erasable elements passing through a macrosymbol. The macrosymbol is composed of both permeable and impermeable boundaries.

```

START WITH AN EMPTY DPF SO THAT THIS FILE CAN BE
RE-INPUT SUCCESSFULLY.
NEWDPF,EMPTYDPF
DRAW,MODEL
803,7=500
    SET CLIP STATUS TO ERASABLE (DEFAULT) AND
    DRAW FENCE STRING
818
825,FEN1
    SET CLIP STATUS TO PERMANENT AND DRAW OVERHEAD
    CABLE STRING (OHC1)
818,PERM
825,OHC1
999
ENHANCE
    DESIGNATE SUBSEQUENT ELEMENTS AS CLIP POLYGONS
    IN THIS CASE MACROSYMBOL TREE WHICH HAS BOTH
    PERMEABLE
    AND IMPERMEABLE ELEMENTS
819,POLY
886,TREE,SYMB,,0.5,501201,111073,0.5,10.0
999
    CREATE CLIPPED DPF
CLIP
FINI
    
```

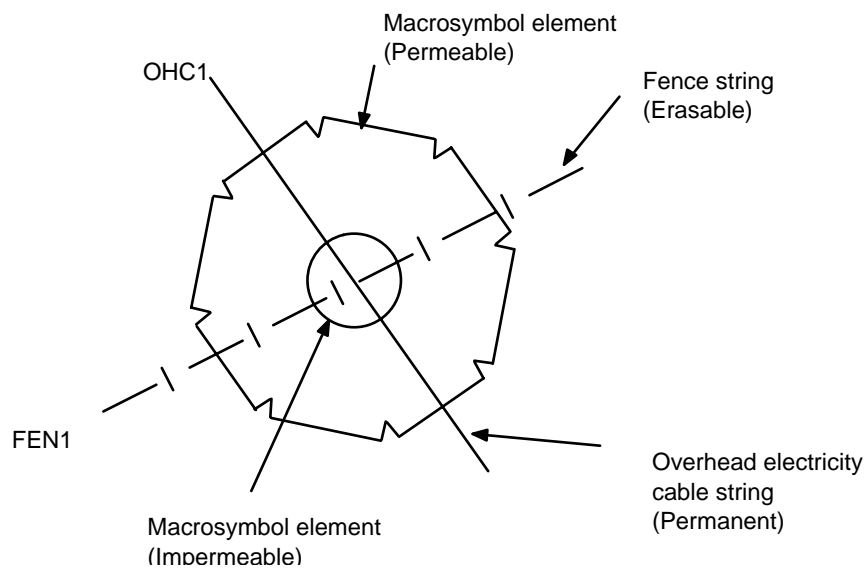
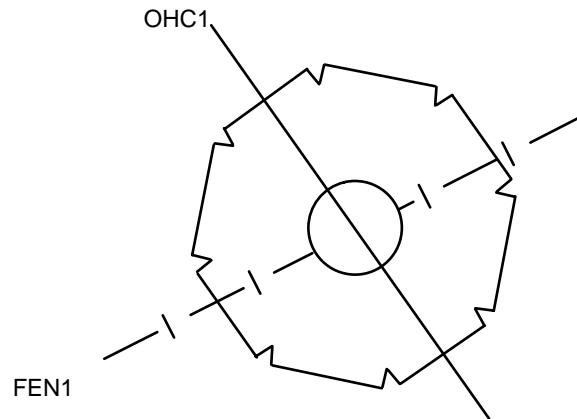


Figure 3 - 178 Macrosymbol before clipping

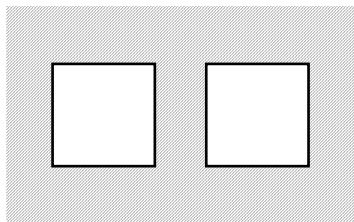


Note that FEN1 has been erased from within the impermeable part of the macro symbol

**Figure 3 - 179 Macro symbol after clipping**

**Example 3**

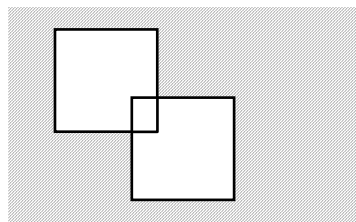
This example illustrates the behaviour of simple ENHANCE boxes as their clip status is changed.



```

SET CLIP STATUS TO PERMANENT
SET ELEMENTS TO CLIP POLYGONS
818,PERM
819,POLY
DRAW BOXES
888,5=10,10,,20,20
888,5=50,10,,60,20 SET CLIP STATUS TO PERM

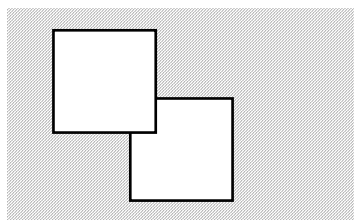
```



```

SET CLIP STATUS TO PERMANENT
SET ELEMENTS TO CLIP POLYGONS
818,PERM
819,POLY
DRAW OVERLAPPING BOXES
888,5=10,10,,20,20
888,5=18,2,,28,12 SET CLIP STATUS TO PERM

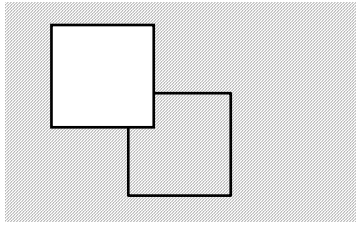
```



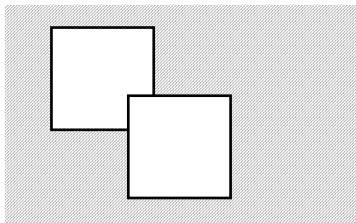
```

SET CLIP STATUS TO PERMANENT
SET ELEMENTS TO CLIP POLYGONS
818,PERM
819,POLY
DRAW LEFT HAND BOX
888,5=10,10,,20,20
SET CLIP STATUS TO ERASABLE
818,ERAS
DRAW RIGHT HAND BOX
888,5=18,2,,28,12 SET CLIP STATUS TO PERM,

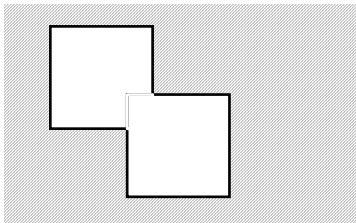
```



SET CLIP STATUS TO PERMANENT  
 SET ELEMENTS TO CLIP POLYGONS  
 818,PERM  
 819,POLY  
 DRAW LEFT HAND BOX  
 888,5=10,10,,20,20  
 SET CLIP STATUS TO ERASABLE  
 SET ELEMENTS TO NORMAL  
 818,ERAS  
 819,NOPO  
 DRAW RIGHT HAND BOX  
 888,5=18,2,,28,12 SET CLIP STATUS TO PERM



SET CLIP STATUS TO ERASABLE  
 SET ELEMENTS TO CLIP POLYGONS  
 818,ERAS  
 819,POLY  
 DRAW LEFT HAND BOX  
 888,5=10,10,,20,20  
 SET CLIP STATUS TO PERMANENT  
 818,PERM  
 DRAW RIGHT HAND BOX  
 888,5=18,2,,28,12 SET CLIP STATUS TO ERAS/



SET CLIP STATUS TO ERASABLE  
 SET ELEMENTS TO CLIP POLYGONS  
 818,ERAS  
 819,POLY  
 DRAW OVERLAPPING BOXES  
 888,5=10,10,,20,20  
 888,5=18,2,,28,12 SET CLIP STATUS TO ERAS/

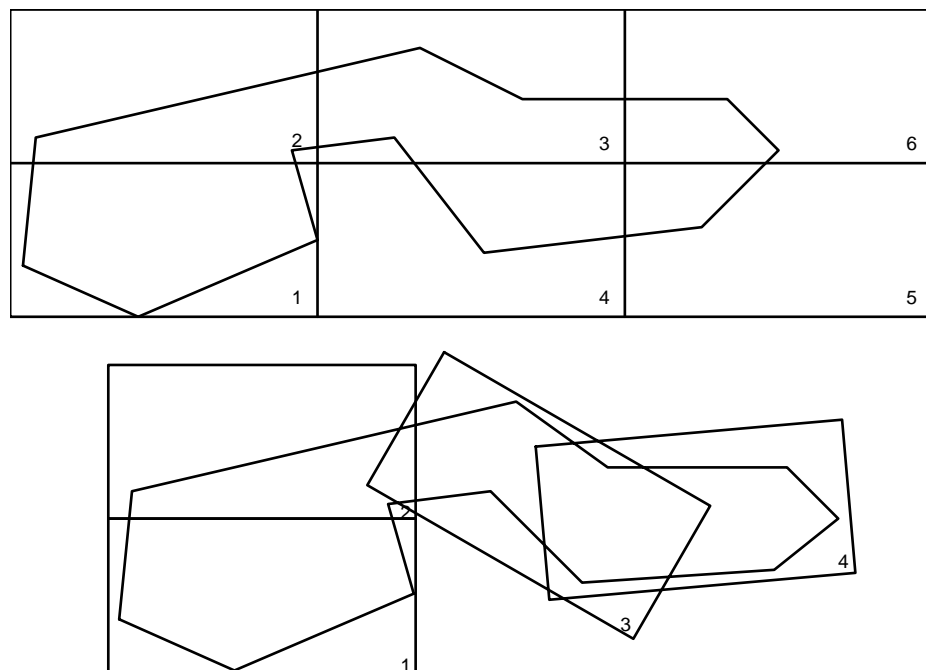
IGGENLT.DAT, GEN005, GEN035

## Major option LAYOUT

Major option LAYOUT is only available in IGMODE.

The option provides interactive facilities to subdivide a Drawing Picture File (DPF) into manageable sheets. The sheets created are a means of quickly specifying areas of the DPF for plotting or display.

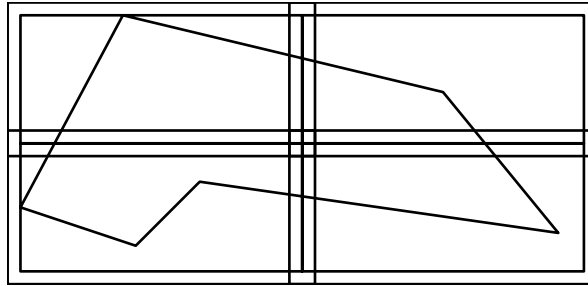
At the initiation of a scheme's design, or when producing contract drawings considerable thought needs to be given to the overall arrangement and management of drawing sheets. Figure 3 - 180 illustrates two possible arrangements.



**Figure 3 - 180 LAYOUT - two possible arrangements**

Other alternatives are obviously available. To assist the engineer in assessing the most favourable layout arrangement major option LAYOUT is provided. LAYOUT only operates from within IGMODE. Usual practise will be to draw either the whole model or the extents of its boundary at small scale and then from within IGMODE superimpose an outline of the drawing sheets as they would appear at a larger scale. For example, draw a model at 1:25000 scale and then visualise the area that an A0 sheet having 2cms margins would cover if the model were drawn at 1:500 scale.





**Figure 3 - 181 Example - LAYOUT with margins**

## Access to major option LAYOUT

IGGENLT.DAT, GEN005

IGLAYT.DAT DRP002

Drawing Options	LAYOUT option details
DRAW Working Drawings	Define sheet properties
DRAW Contract Drawings	Sheet position method
ENHANCE Drawings	Modify a set of sheets
Add annotation	Create Draw data/strings
CLIP drawings	End layout options
LAYOUT	
Drawing sheets	
MACROSYMBOLS	
Create/amend/store	
VIEW	
Perspective/Photo	
VISUALISE	
Prepare EPIC data	
2DDXF	
DPF conversion to DXF	
NEW DPF Select DPF	
NEW RPF Select RPF	
REPORT	
Models/strings/points	

Entry to LAYOUT will cause the 'Define sheet properties' menu to be displayed.

## Define sheet properties

IGLAYOT.DAT, DRP001

Define sheet properties
Sheet set identifier
Layout drawing scale
International sheet size
Sheet length
Sheet width
Constant margin width
Bottom margin width
Left margin width
Top margin width
Right margin width

**Sheet set identifier.** Two characters must be defined and each new sheet positioned will thereafter be sequentially numbered.

**Layout drawing scale.** Whilst the base drawing will already have its scale specified the layout scale may be varied at the users discretion.

**International sheet size.** The proposed sheet sizes may be defined either as sheet width and length or as standard A or B sizes. Note that if these sizes are defined within 1cms of the predefined A/B size then the A/B size will be taken.

**Constant or bottom, left, top and right margins.** Margins for the proposed sheet may be given and the drawing window within the sheet will be shown on the layout.

When you have entered the required information or accepted the defaults, select Proceed to display the main 'Layout option details' menu. This menu allows you to select the LAYOUT option you require.

### Sheet position method

IGLAYOT.DAT, DRP002, DRP003

LAYOUT option details	Sheet position method
Define sheet properties	BL & point on LHS
Sheet position method	BL & bearing of LHS
Modify a set of sheets	Relative to existing sheet
Create Draw data/strings	Return to previous menu
End layout options	

IGLAYOT.DAT, DRP003, DRP005

Sheet position method	BL & pt/brg on LHS
BL & point on LHS	Sheet name
BL & bearing of LHS	BL X coordinate
Relative to existing sheet	BL Y coordinate
Return to previous menu	Bearing of LHS
	Bearing adjustment value
	Adjust BRG anti clockwise
	Adjust BRG clockwise

Each sheet may be positioned according to its **bottom left hand side** and a **point** or **rotation**. An incremental rotation may also be applied to adjust the outline into its correct position.

IGLAYOT.DAT, DRP003, DRP004

Sheet position method	Relative to existing sheet
BL & point on LHS	Existing sheet name
BL & bearing of LHS	Position above
Relative to existing sheet	Position below
Return to previous menu	Position to right
	Position to left
	Overlap (in model units)
	Return to previous menu

Following the positioning of one sheet, subsequent sheets may be positioned **relative** to it by requesting the next sheet to be adjacent to the last (above, below, to the left or to the right) with provisions for an optional overlap.

When you have positioned all sheets their outlines will be shown on the base drawing. Should you wish to modify any sheet or resequence the sheets select 'Modify a set of sheets.'

## Modify a set of sheets

IGLAYOT.DAT, DRP002, DRP006

LAYOUT option details	Modify a set of sheets
Define sheet properties	Sheet set identifier
Sheet position method	Renumber/delete sheets
Modify a set of sheets	Cancel renumber/delete
Create Draw data/strings	Accept renumber/delete
End layout options	Return to previous menu

**Renumber/delete sheets** allows you to change the sequence number of the sheets. After choosing this option select the sheets from the screen in the sequence in which they are to be numbered. Beware! any sheet not selected will be deleted if you select Accept renumber/delete. Quit will enable you to add the unselected sheet(s).

## Create DRAW data/strings

Create DRAW data/strings allows you to:

- output drawing parameters for each sheet to a named file.
- store the sheets as strings in the model file.

IGLAYOT.DAT, DRP002, DRP007

LAYOUT option details	Create Draw data/strings
Define sheet properties	Sheet set identifier
Sheet position method	Create Draw details (T)
Modify a set of sheets	Output file name
Create Draw data/strings	Store sheets as strings (T)
End layout options	Model name

**Sheet set identifier** defines the sheets to be output.

**Create Draw details** is a toggle which determines if drawing parameters are output to a named file. If it is set to YES, an **output file name** must be specified.

The drawing parameters are output in the form of DRAW 802/803/804 minor option data so that you may build up the drawing sheets at the desired scale in major option DRAW.

**Store sheets as strings** is a toggle which determines if the sheets are stored as strings in the model file. If it is set to YES, a **model name** must be specified.

On Proceed, the sheet data is output to the specified destinations.

If you select Quit, no sheet data is output. However, LAYOUT details are retained so that you may make further modifications or additions. The LAYOUT details are retained until you exit major option LAYOUT.

If you select Abandon, the LAYOUT details are lost.

# Chapter 4 General options

## General options

### Major option EDIT

Major option EDIT encompasses minor options numbered between 002 and 036, which:

- add strings to a model
- modify data within existing strings
- build strings from parts of others
- delete all or part of a string.

The full set is:

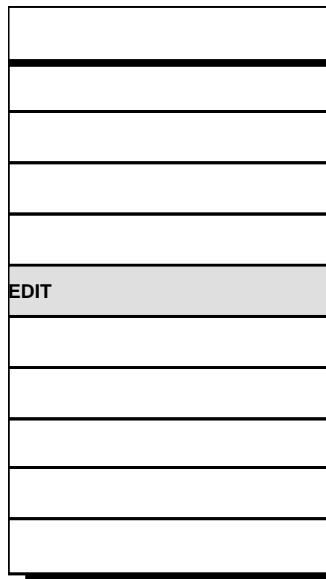
002	Create a text/contour string
004	Delete an entire string
005	Delete part of a string
006	Add one discontinuity
007	Add some discontinuities
008	Create a string
009	Create a boundary string
010	Create a string (from between intersection points) (used with 008/009)
012	Join two strings
020	Change string label / Change contour level
021	Change any string dimension
022	Change string dimension 1/2/3
023	Add a point before a point
024	Add a point after a point
025	Delete a point
026	Insert a point
027	Convert to a 6D M-string
028	Create string with extra points
029	Generate M-String from a geometry string
030	Change series of labels
031	Delete a series of strings
032	Delete loops/tail ends
033	Change string sub-reference
035/036	Add slope signature string
037	Create cadastre string
038	Change cadastre point Change symbol reference bearing

You use EDIT during all stages of an engineering design:

- for the existing surface - to correct erroneous levels and the ground position of points and strings
- for feature design - to remove redundant sections of strings where they intersect other features, to insert non-standard features
- for analysis - to create boundaries within which volumes are derived
- for visualisation - to enhance and improve model information for drawings

EDIT works to best advantage in graphics mode, but there are linemode equivalents for each EDIT function.

## Access to major option EDIT





## Model for EDIT

### Input

#### Graphics

IGEDITT.DAT, EDI001

Model for EDIT
Model to be edited

### Linemode

EDIT options all follow the standard minor option format.

#### Minor option EDIT

1st Model 1 Model containing strings to be manipulated

◇ *Global options 000, 001, 017, 018, 019, 900, and 999 may be used in EDIT.*

## Minor option 002 Create a text string

Adds text information to associated spatial information. Subsequently this text information can be drawn.

For bulk input of text with associated spatial information GENIO 080 is more efficient.

Input

Graphics

IGEDIT.DAT, EDI002, EDI042, EDI047

EDIT minor options	Create special strings	Create a text string
Create a string	Create text string	New string label
Create a boundary string	Create contour string	Add text
Create special strings	Create cadastre string	X coordinate
Delete an entire string		Y coordinate
Delete part of a string		BRG of baseline
Join two strings		Character height
Add one discontinuity		
Add some discontinuities		
Add comments to input log		
Define system parameters		

Linemode

Minor option 002

- \* Field 3 String label. It must have an \* as first character.
- \* Field 5 & 6 Coordinate position of bottom left of first character
- Field 7 Bearing of base line of characters  
Default is 0.0
- Field 9 Character height (drawing units)  
Default is 0.15

Follow each 002 option with one 001 option containing the text information.

Minor option 001

- \* Cols 4-43 Text to be stored.
  - ◇ *If you give the bearing and/or the character height the values will be used for subsequent 002 options in your current session.*
  - ◇ *Each 002 option requires a new string label.*
  - ◇ *The dimension of the string created will depend on the number of characters in the text, up to a maximum 44 characters.*

## Minor option 002 Create a contour string

### Input

### Graphics

IGEDITT.DAT, EDI002, EDI042, EDI048

EDIT minor option:	Create special strings	Create a contour string
Create a string	Create text string	New string label
Create a boundary string	Create contour string	Contour level
Create special string:	Create cadastre string	Point X
Delete an entire string		Y
Delete part of a string		
Join two strings		
Add one discontinuity		
Add some discontinuities		
Add comments to input log		
Define system parameter:		

This option automatically gets submitted and redisplayed on completion of the X/Y field.

The first submission must contain entries in all four fields but to continue the existing strings the X/Y point need only be modified on subsequent submissions.

### Linemode

#### Minor option 002

- \* Field 3 Name of string being added
- \* Field 4 Contour level. (This should only be typed on the first record)
- Field 5 First dimension value (X coordinate)
- Field 6 Second dimension value (Y coordinate)

## Minor option 004 Delete an entire string

### Input

### Graphics

IGEDITT.DAT, EDI002, EDI003

EDIT minor options	Delete an entire string
Create a string	String label
Create a boundary string	
Create special strings	
Delete an entire string	
Delete part of a string	
Join two strings	
Add one discontinuity	
Add some discontinuities	
Add comments to input log	
Define system parameters	

### Linemode

#### Minor option 004

- \* Field 3 Name of string to be deleted
  - ◇ *To delete a triangulation string first select the triangulation model ie modelname TRIA then delete string by specifying label. To determine the label use REPORT option 991.*
  - ◇ *No other information is given on the minor option.*
  - ◇ *Strictly, field 3 is for defining the label of string to be deleted but for historical reasons field 1 may be used instead. 004, LAB1 is interpreted as 004, 3=LAB1.*
  - ◇ *To delete a set of strings, use option 031.*

## Minor option 005 Delete part of a string

### Input

### Graphics

IGEDITT.DAT, EDI002, EDI004

EDIT minor options	Delete part of a string
Create a string	Label of string to amend
Create a boundary string	Start chainage / X coord
Create special strings	Start point no. / Y coord
Delete an entire string	End chainage / X coord
Delete part of a string	End point no. / Y coord
Join two strings	
Add one discontinuity	
Add some discontinuities	
Add comments to input log	
Define system parameters	

You delete parts of strings by removing the points between two limits specified by reference points

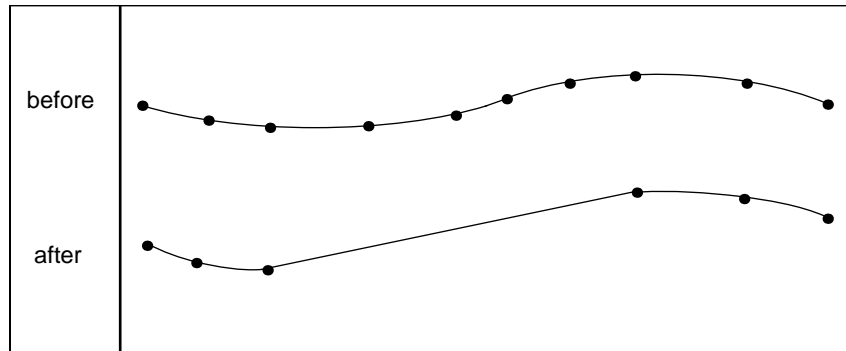
The point selection methods, together with the point amend functions, define the two limits.

- ◇ *The reference points remain in the string unless the start or end of the string is implied. The points between the two limits are removed.*
- ◇ *The string is assumed to be continuous between the two limits. If this is not the case then use option 006 to insert a discontinuity.*
- ◇ *The point sequence numbers of all points following the first limit will be renumbered to allow for the points deleted.*
- ◇ *You will be stopped from deleting the whole string (by leaving undefined the start and end points). If you wish to delete the whole string, use option 004.*

Linemode

The on-line flexibility of the point selection methods is not available in linemode. Identify from the following diagrams the scheme which represents your requirements and prepare your data accordingly.

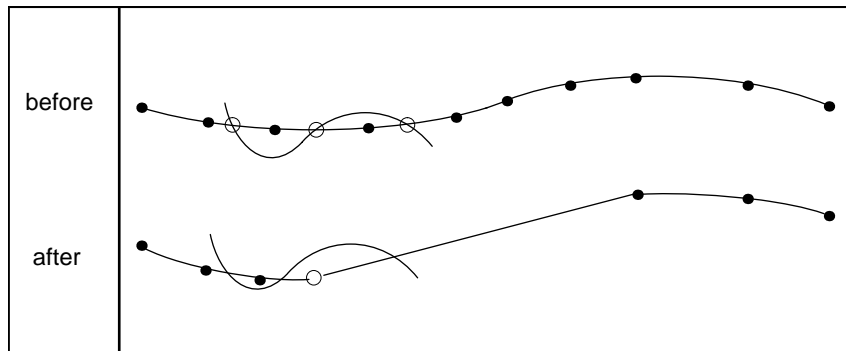
**Case 1 Between two points**



**Figure 4 - 1 Example - case 1**

- \* Field 3 String to be amended
- Fields 5 & 6 SPRD for start
- Fields 8 & 9 SPRD for end

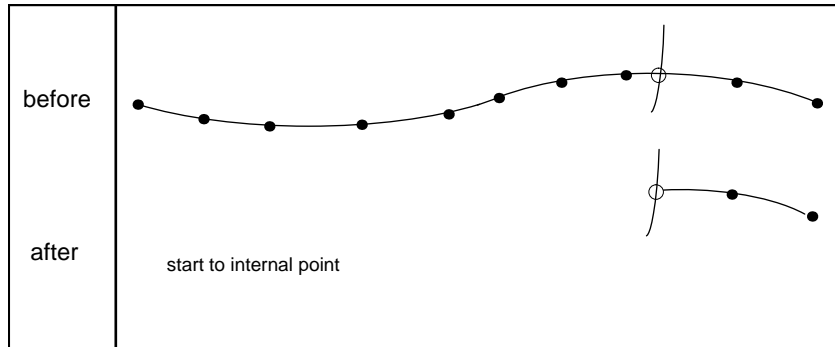
**Case 2 From an intersection to a point.**



**Figure 4 - 2 Example - case 2**

- \* Field 1 Intersecting string label
- \* Field 3 String to be amended
- \* Field 7 Sequence number of required intersection
- Fields 8 & 9 SPRD for end

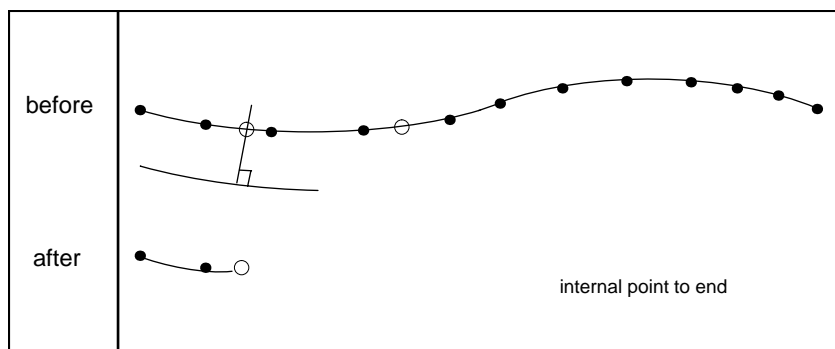
**Case 3 From specified point to string intersection**



**Figure 4 - 3 Example - case 3**

- \* Field 2 Intersecting string label
- \* Field 3 String to be amended
- Fields 5 & 6 SPRD for specified point
- \* Field 10 Sequence number of required intersection

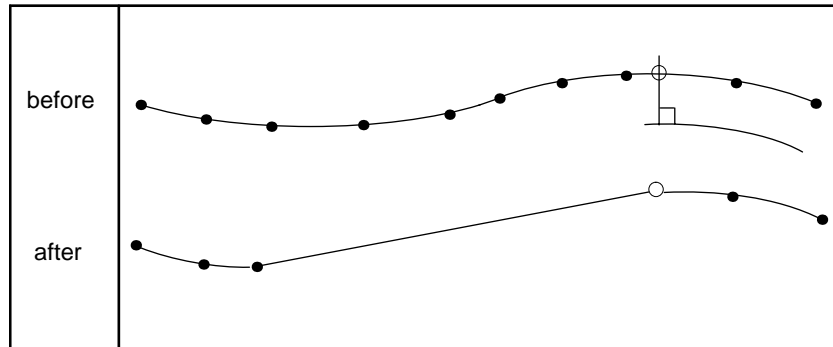
**Case 4 From normal intersection to specific point**



**Figure 4 - 4 Example - case 4**

- \* Field 1 Intersecting string label
- \* Field 3 String to be amended
- \* Fields 5 & 6 SPRD for point generating normal
- \* Field 7 Sequence number of required intersection
- Fields 8 & 9 SPRD for specified point

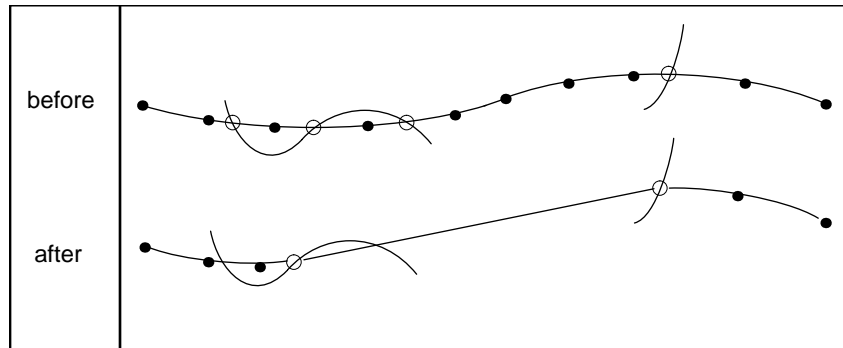
**Case 5 From specified point to normal intersection**



**Figure 4 - 5 Example - case 5**

- \* Field 2 Intersecting string label
- \* Field 3 String to be amended
- \* Fields 5 & 6 SPRD for specified point
- \* Fields 8 & 9 SPRD for point generating normal
- \* Field 10 Sequence number of required normal intersection

**Case 6 From string intersection to string intersection**

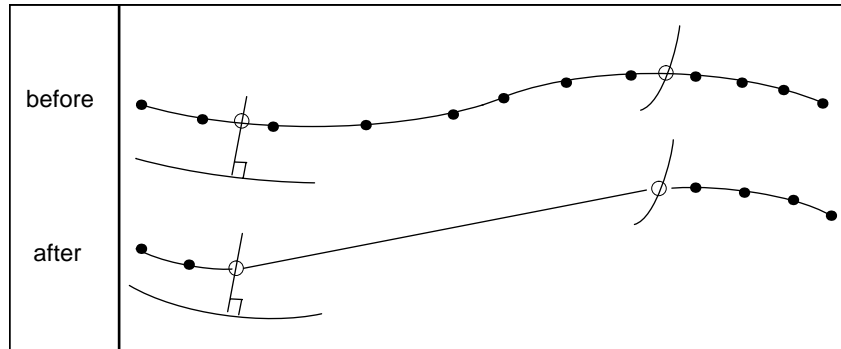


**Figure 4 - 6 Example - case 6**

- \* Field 1 Intersecting string label at start
- \* Field 2 Intersecting string label at end
- \* Field 3 String to be amended
- \* Field 7 Sequence number of required intersection at start
- \* Field 10 Sequence number of required intersection at end



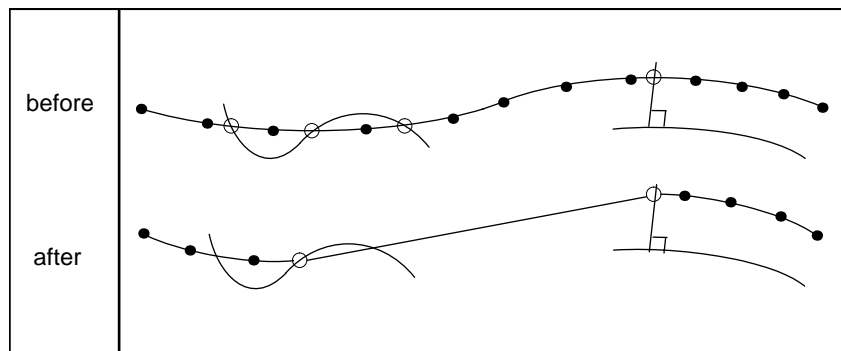
**Case 7 From normal intersection to string intersection**



**Figure 4 - 7 Example - case 7**

- \* Field 1 Intersecting string label at start
- \* Field 2 Intersecting string label at end
- \* Field 3 String to be amended
- \* Fields 5 & 6 SPRD for point generating normal
- \* Field 7 Sequence number of required intersection at start
- \* Field 10 Sequence number of required intersection at end

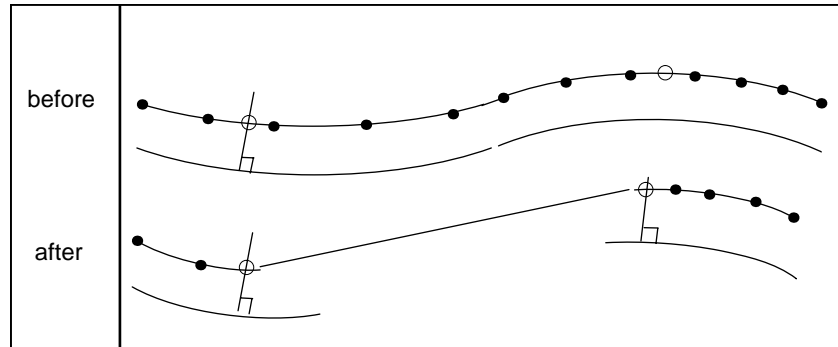
**Case 8 From string intersection to a normal intersection**



**Figure 4 - 8 Example - case 8**

- \* Field 1 Intersecting string label at start
- \* Field 2 Intersecting string label at end
- \* Field 3 String to be amended
- \* Field 7 Sequence number of required intersection at start
- \* Fields 8 & 9 SPRD for point generating normal
- \* Field 10 Sequence number of required intersection at end

**Case 9 From a normal intersection to a normal intersection**



**Figure 4 - 9 Example - case 9**

- \* Field 1 Intersecting string label at start
- \* Field 2 Intersecting string label at end
- \* Field 3 String to be amended
- \* Fields 5 & 6 SPRD for point generating normal at start
- \* Field 7 Sequence number of required normal intersection at start
- \* Fields 8 & 9 SPRD for point generating normal at end
- \* Field 10 Sequence number of required normal intersection at end

**Minor option 006 Add one discontinuity**

Inserts a discontinuity (for example, a gate) into a string.

Input

Graphics

IGEDITT.DAT, EDI002, EDI005

EDIT minor options	Add one discontinuity
Create a string	Label of string to amend
Create a boundary string	Start chainage / X coord
Create special strings	Start point no. / Y coord
Delete an entire string	End chainage / X coord
Delete part of a string	End point no. / Y coord
Join two strings	
Add one discontinuity	
Add some discontinuities	
Add comments to input log	
Define system parameters	

You add a discontinuity by removing the points between two limits specified by the reference points. The string is not considered to be joined between these two points.

The point selection methods, together with the point amend functions, define the two limits.

- ◇ *The reference points remain in the string but the points between the two limits are removed.*
- ◇ *The point sequence numbers of all points following the first limit point will be renumbered to allow for the points deleted.*

Linemode

Fields should be coded in a similar way to minor option 005.

The on-line flexibility of the point selection methods is not available in linemode. Identify from the diagrams shown for option 005, the scheme which represents your requirements and prepare your data in the same way but replacing option 005 by 006.

**Minor option 007 Add some discontinuities**

Inserts more than one discontinuity into a string.

In a survey you may wish to record all field gates, each as two points, into one string. Between each pair of points the string is discontinuous. This option can be used to insert these discontinuities, and to specify the increment.

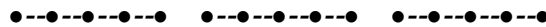
Input

Graphics

IGEDITT.DAT, EDI002, EDI006

EDIT minor options	Add some discontinuities
Create a string	Label of string to amend
Create a boundary string	Number of points between
Create special strings	
Delete an entire string	
Delete part of a string	
Join two strings	
Add one discontinuity	
Add some discontinuities	
Add comments to input log	
Define system parameters	

◇ The number of points between each discontinuity is the variable.



In the diagram the value to be given to the number of points between discontinuities is 5.

◇ Any existing discontinuity conflicting with a new one will be removed.

Linemode

Minor option 007

- \* Field 3      String to be amended
- Field 4      Number of points between discontinuities

Minor option 008    Create a string

Minor option 008 is for creating a new string. The created string points may be defined by any Point Selection Method in Graphics, and by SPRD in Linemode. A part of a string is always defined by a start point and an end point. The start and end points can be specified either:

- by coordinates
- or by intersection with other strings

The graphics menus for 008 are all presented below. Linemode fields for all cases follow these.

Input

Graphics

IGEDITT.DAT, EDI002, EDI007, EDI008

EDIT minor options:	Create a string	Part of a string
Create a string	Part of a string	New string label
Create a boundary string	One or two points	Reference string
Create special string:	Polystring string points	Start chainage / X coord
Delete an entire string	Polystring X/Y points	Start point no. / Y coord
Delete part of a string	Offset point location	End chainage / X coord
Join two strings		End point no. / Y coord
Add one discontinuity		Single point indicator (T)
Add some discontinuities		
Add comments to input log		
Define system parameter:		

**New string label:** On each entry to this option you will be prompted to type in the new string label. After the first entry, press [Return] to retain the label that has already been given.

**Start and end points:** If only one point is being added then this should be the start point.

**Single point indicator:** A toggle switch lets you specify whether or not only one point is being added to the string.

◇ *The X, Y and Z coordinates of every point between the start and end point will be contained in the new string.*

EDI002, EDI007, EDI009

EDIT minor options:	Create a string	One or two points
Create a string	Part of a string	New string label
Create a boundary string	One or two points	Point 1 X
Create special string:	Polystring string points	Y
Delete an entire string	Polystring X/Y points	Level 1
Delete part of a string	Offset point location	Point 2 X
Join two strings:		Y
Add one discontinuity:		Level 2
Add some discontinuities:		Single point indicator (T)
Add comments to input log:		
Define system parameter:		

**Single point indicator:** A toggle switch lets you indicate whether or not only one point is being added to the string.

- ◇ Use this route if the points being identified are not contained within a string.
- ◇ No levels are associated with each point.

IGEDITT.DAT, EDI002, EDI007, EDI036

EDIT minor options:	Create a string	Polystring string points
Create a string	Part of a string	New string label
Create a boundary string	One or two points	Point X
Create special string:	Polystring string points	Y
Delete an entire string	Polystring X/Y points	Level
Delete part of a string	Offset point location	
Join two strings:		
Add one discontinuity:		
Add some discontinuities:		
Add comments to input log:		
Define system parameters:		

On first asking for this menu you will be prompted for the new string label. You will then be automatically prompted to select a point to be added to the string. Use any of the point selection methods. The point will be immediately displayed and you can continue adding points changing the

point selection method as appropriate. When you have added all the points you want, select QUIT to return to the higher level.

- ◇ *Use of PSM XY with this option will automatically generate a string with null levels.*

**IGEDITT.DAT, EDI002, EDI007, EDI035**

EDIT minor option:	Create a string	Polystring X/Y points
Create a string	Part of a string	New string label
Create a boundary string	One or two points	Level
Create special string:	Polystring string points	Point X
Delete an entire string	Polystring X/Y points	Y
Delete part of a string	Offset point location	
Join two strings		
Add one discontinuity		
Add some discontinuities		
Add comments to input log		
Define system parameter:		

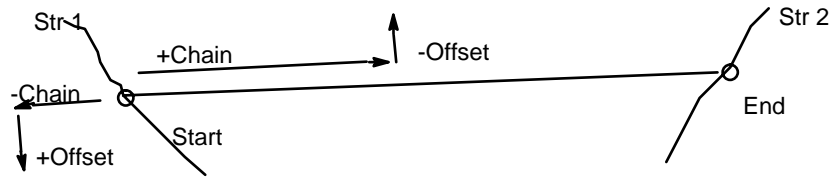
**IGEDITT.DAT, EDI002, EDI007, EDI041**

EDIT minor option:	Create a string	Offset point location
Create a string	Part of a string	New string label
Create a boundary string	One or two points	Label of baseline string 1
Create special string:	Polystring string points	Start chainage / X coord
Delete an entire string	Polystring X/Y points	Start point no. / Y coord
Delete part of a string	Offset point location	Label of baseline string 2
Join two strings		End chainage / X coord
Add one discontinuity		End point no. / Y coord
Add some discontinuities		Chainage from start
Add comments to input log		Horizontal offset
Define system parameter:		Level of point

Offset point location is a special use of the 008/009 option to produce a string of points generated using chain and offset style of input related to existing string points.

Two existing string points are selected to form a base line, and a new point can then be defined in terms of a local chainage from the beginning of the base line, and offset to either side.

Levels can be added to the string if available.



**Figure 4 - 10 Example - Offset point location**

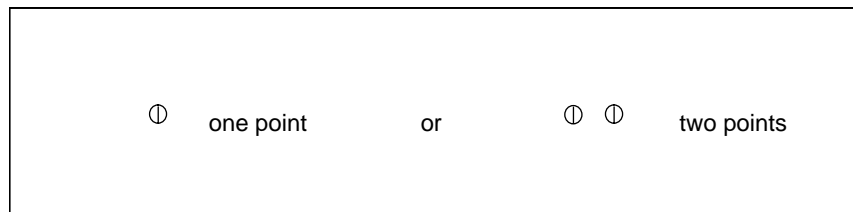
On first asking for the menu you will be prompted for all the relevant data. The menu will be automatically redisplayed to continue the string by inserting new chainage values. Select QUIT to return to a higher level.

Linemode

Minor option 008

Identify from the following diagrams the arrangement which represents your requirements and prepare your data accordingly.

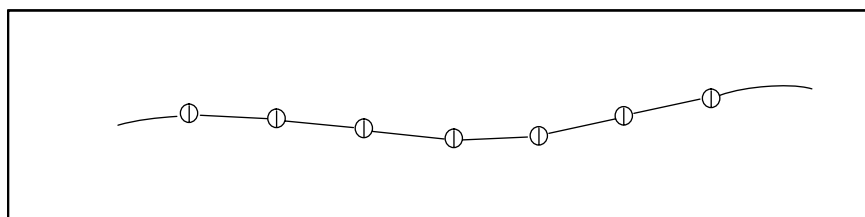
**Case 1 One or two points**



**Figure 4 - 11 Example - case 1**

- \* Field 3 New string label
- \* Fields 5 & 6 First and second dimensions of point
- Field 7 Third dimension of point. (optional)
- Fields 8 & 9 First and second dimensions of point
- Field 10 Third dimension of point. (optional)

**Case 2 Part of string**

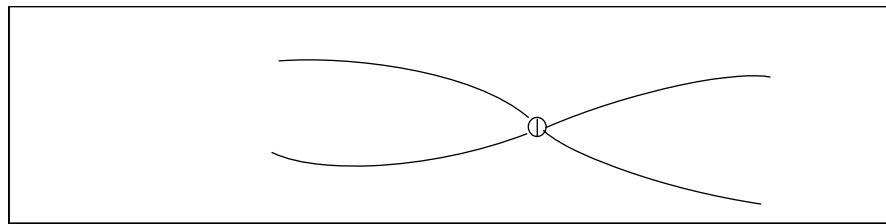


**Figure 4 - 12 Example - case 2**



- \* Field 1 Label or string from which points are to be extracted.
- \* Field 3 New string label
- Field 4 Single point identifier. Type 1.
- Fields 5 & 6 SPRD for first point to be sent to string. If omitted, the start of the string is assumed.
- Fields 8 & 9 SPRD for the last point to be sent to string. If omitted, then the end of the string is assumed. These fields are ignored if field 4 is typed (send one point only).

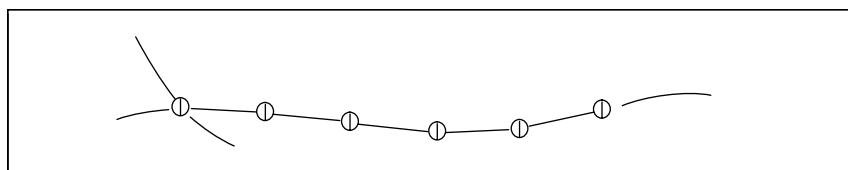
**Case 3 Intersection of two strings**



**Figure 4 - 13 Example - case 3**

- \* Fields 1 & 2 Labels of intersecting strings. Note that the level taken is that of the string in field 1.
- \* Field 3 New string label
- Field 4 Single point identifier. Type 1.
- \* Field 7 Sequence number of required intersection of string in field 1 with string in field 2.

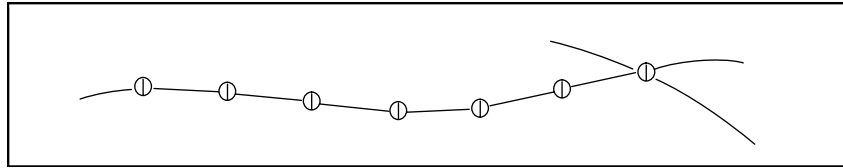
**Case 4 From string intersection to specified point**



**Figure 4 - 14 Example - case 4**

- \* Field 1 Label of string from which points are extracted.
- \* Field 2 Label of string that intersects string in field 1. The intersection point defines the first point to be sent.
- \* Field 3 New string label
- \* Field 7 Sequence number of required intersection of string in field 1 with string in field 2.
- Fields 8 & 9 Identification of last point to be sent. If omitted then the end of the string is assumed.

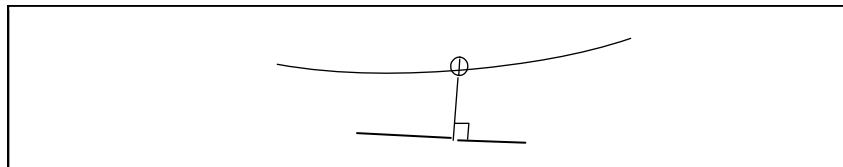
**Case 5 From specified point to string intersection**



**Figure 4 - 15 Example - case 5**

- \* Field 1 Label of string from which points are extracted.
- \* Field 2 Label of string that intersects string in field 1. The intersection point defines the last point to be sent.
- \* Field 3 New string label
- \* Fields 5 & 6 SPRD for first point to be sent. If omitted then the start of string is assumed.
- \* Field 10 Sequence number of required intersection of string in field 1 with string in field 2.

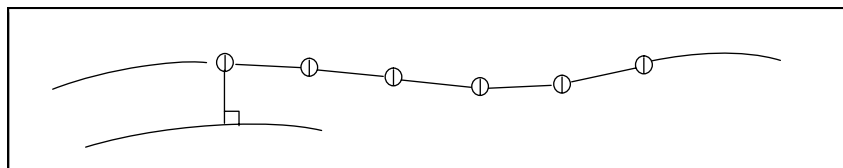
**Case 6 Intersection of string with normal from another string**



**Figure 4 - 16 Example - case 6**

- \* Field 1 Label of string that intersects normal.
- \* Field 2 Label of string generating normal.
- \* Field 3 New string label
- Field 4 Single point identifier. Type 1.
- \* Fields 5 & 6 Identification of point on string in field 2 generating normal.
- \* Field 7 Sequence number of required intersection of normal with string in field 1.

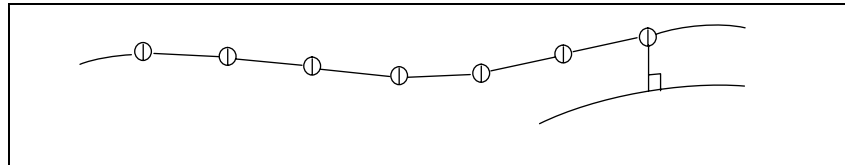
**Case 7 From normal intersection to specified point**



**Figure 4 - 17 Example - case 7**

- \* Field 1 Label of string from which points are extracted.
- \* Field 2 Label of string generating normal.
- \* Field 3 New string label
- \* Fields 5 & 6 SPRD of point on string in field 2 generating normal.
- \* Field 7 Sequence number of required intersection.
- Fields 8 & 9 SPRD of last point to be sent.

**Case 8 From specified point to normal intersection**



**Figure 4 - 18 Example - case 8**

- \* Field 1 Label of string from which points are extracted.
- \* Field 2 Label of string generating normal.
- \* Field 3 New string label
- Fields 5 & 6 SPRD for first point to be sent.  
If omitted then the start of string is assumed.
- \* Fields 8 & 9 SPRD for point on string in field 2 generating normal.
- \* Field 10 Sequence number of required intersection of normal with string in field 1.

**Case 9 Offset point location**

- Field 1 String providing point at beginning of base line
- \* Field 2 String providing point at end of base line
- \* Field 3 String to which point will be added
- Field 4 Real level of point being created (default null level)
- \* Fields 5 & 6 SPRD at point from field 1 string
- \* Field 7 Chainage from beginning of base line
- \* Fields 8 & 9 SPRD at point from field 2 string
- \* Field 10 Horizontal offset.

There are also the following cases, which are covered by option 010 :

- Case 10 : From string intersection to string intersection
- Case 11 : From normal intersection to string intersection
- Case 12 : From string intersection to normal intersection
- Case 13 : From normal intersection to normal intersection

## Minor option 009 Create a boundary string

Minor option 009 is for creating a boundary string. The created string points may be defined by any Point Selection Method in Graphics, and by SPRD in Linemode.

Boundary strings are strings that are topologically closed (that is, they form a single closed circuit of any shape). They are very useful for marking out areas within which (or outside which) to contour, calculate areas or volumes, copy or draw.

Minor option 009 is identical to 008 with three important differences:

- For each string created the last point is always identical to the first.
- You can't use the offset point location feature
- A boundary string may be created from strings containing discontinuities. In the boundary string itself, discontinuities from donor strings become string links.

A warning is given if any donor string contains a discontinuity.

Menus notes are the same as for 008/Create a string.

◇ *Minor option 009 allows a maximum of 3000 points on a boundary string.*

### Input

### Graphics

IGEDITT.DAT, EDI002, EDI010, EDI011

EDIT minor option:	Create a boundary string	Part of a string
Create a string	Part of a string	New string label
Create a boundary string	One or two points	Reference string
Create special string:	Polystring string points	Start chainage / X coord
Delete an entire string	Polystring X/Y points	Start point no. / Y coord
Delete part of a string		End chainage / X coord
Join two strings		End point no. / Y coord
Add one discontinuity		Single point indicator (T)
Add some discontinuities		
Add comments to input log		
Define system parameter:		

IGEDITT.DAT, EDI002, EDI010, EDI012

EDIT minor option:	Create a boundary string	One or two points
Create a string	Part of a string	New string label
Create a boundary string	One or two points	Point 1 X
Create special string:	Polystring string points	Y
Delete an entire string	Polystring X/Y points	Level 1
Delete part of a string		Point 2 X
Join two strings		Y
Add one discontinuity:		Level 2
Add some discontinuities:		Single point indicator (T)
Add comments to input log:		
Define system parameter:		

IGEDITT.DAT, EDI002, EDI010, EDI037

EDIT minor option:	Create a boundary string	Polystring string X/Y points
Create a string	Part of a string	New string label
Create a boundary string	One or two points	Point X
Create special string:	Polystring string points	Y
Delete an entire string	Polystring X/Y points	Level
Delete part of a string		
Join two strings		
Add one discontinuity:		
Add some discontinuities:		
Add comments to input log:		
Define system parameter:		

IGEDITT.DAT, EDI002, EDI010, EDI038

EDIT minor options:	Create a boundary string	Polystring X/Y points
Create a string	Part of a string	New string label
Create a boundary string	One or two points	Level
Create special string:	Polystring string points	Point X
Delete an entire string	Polystring X/Y points	Y
Delete part of a string		
Join two strings		
Add one discontinuity		
Add some discontinuities		
Add comments to input log		
Define system parameter:		

◇ When you have finished selecting all the points you must return to the minor option level.

Linemode

Minor option 009

Identify from the following diagrams the scheme which represents your requirements and prepare your data accordingly.

Case 1 One or two points

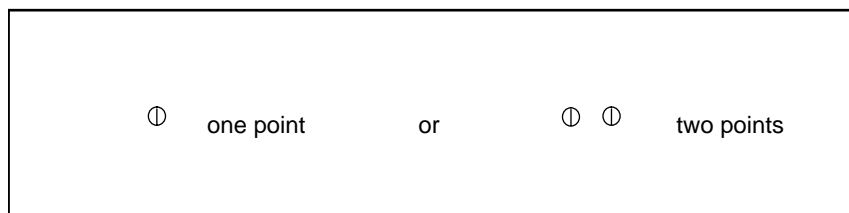
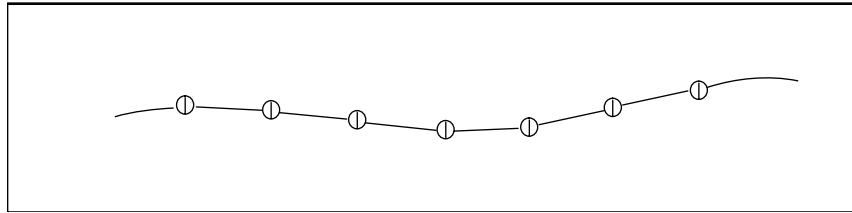
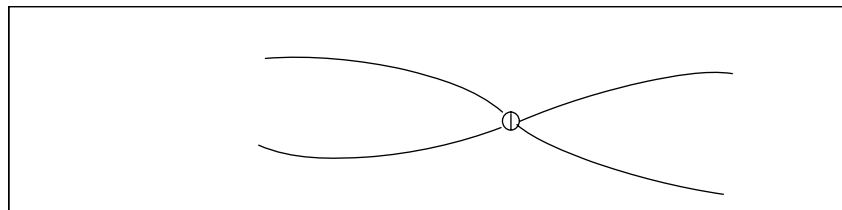


Figure 4 - 19 Example - case 1

- \* Field 3            New boundary string label
- \* Fields 5 & 6    First and second dimensions of point
- Field 7            Third dimension of point. (optional)
- Fields 8 & 9     First and second dimensions of point
- Field 10          Third dimension of point. (optional)

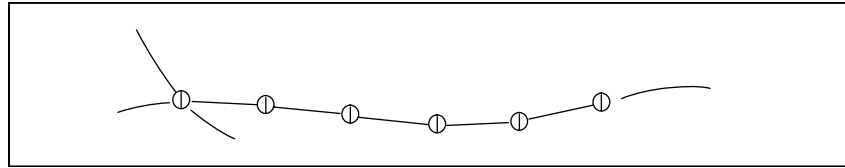
**Case 2 Part of a string****Figure 4 - 20 Example - case 2**

- \* Field 1 Label or string from which points are to be extracted.
- \* Field 3 New boundary string label
- Field 4 If only one point is to be sent to the boundary string, type 1.0
- Fields 5 & 6 SPRD for first point to be sent to boundary string. If omitted, the start of the string is assumed.
- Fields 8 & 9 SPRD for the last point to be sent to boundary string. If omitted, then the end of the string is assumed. These fields are ignored if field 4 is typed (send one point only).

**Case 3 Intersection of two strings****Figure 4 - 21 Example - case 3**

- \* Fields 1 & 2 Labels of intersecting strings. Note that the level taken is that of the string in field 1.
- \* Field 3 New boundary string label
- Field 4 Single point identifier. Type 1.
- \* Field 7 Sequence number of required intersection of string in field 1 with string in field 2.

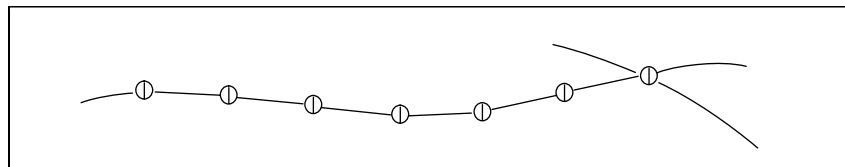
**Case 4 From string intersection to specified point**



**Figure 4 - 22 Example - case 4**

- \* Field 1 Label of string from which points are extracted.
  - \* Field 2 Label of string that intersects string in field 1. The intersection point defines the first point to be sent.
  - \* Field 3 New boundary string label
  - \* Field 7 Sequence number of required intersection of string in field 1 with string in field 2.
- Fields 8 & 9 Identification of last point to be sent. If omitted then the end of the string is assumed.

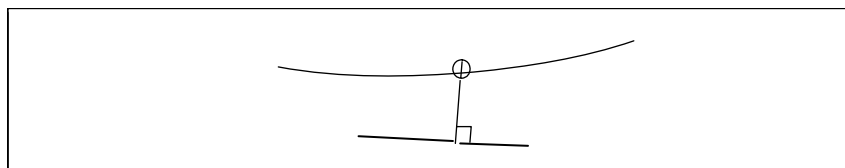
**Case 5 From specified point to string intersection**



**Figure 4 - 23 Example - case 5**

- \* Field 1 Label of string from which points are extracted.
  - \* Field 2 Label of string that intersects string in field 1. The intersection point defines the last point to be sent.
  - \* Field 3 New boundary string label
- Fields 5 & 6 SPRD for first point to be sent. If omitted then the start of string is assumed.
- \* Field 10 Sequence number of required intersection of string in field 1 with string in field 2.

**Case 6 Intersection of string with normal from another string**

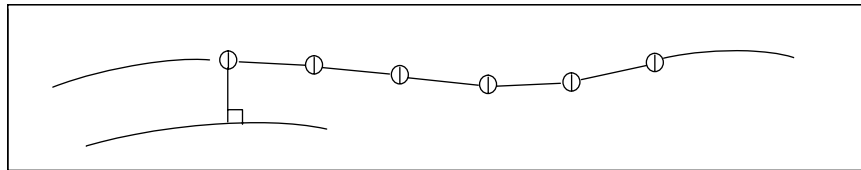


**Figure 4 - 24 Example - case 6**



- \* Field 1 Label of string that intersects normal.
- \* Field 2 Label of string generating normal.
- \* Field 3 New boundary string label
- Field 4 Single point identifier. Type 1.
- \* Fields 5 & 6 Identification of point on string in field 2 generating normal.
- \* Field 7 Sequence number of required intersection of normal with string in field 1.

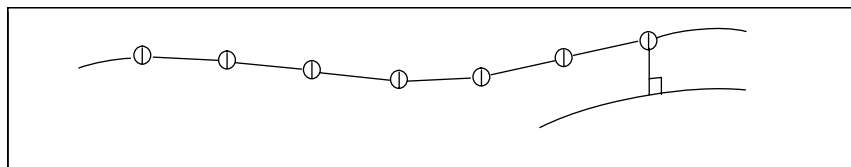
**Case 7 From normal intersection to specified point**



**Figure 4 - 25 Example - case 7**

- \* Field 1 Label of string from which points are extracted.
- \* Field 2 Label of string generating normal.
- \* Field 3 New boundary string label
- \* Fields 5 & 6 SPRD of point on string in field 2 generating normal.
- \* Field 7 Sequence number of required intersection.
- \* Fields 8 & 9 SPRD of last point to be sent.

**Case 8 From specified point to normal intersection**



**Figure 4 - 26 Example - case 8**

- \* Field 1 Label of string from which points are extracted.
- \* Field 2 Label of string generating normal.
- \* Field 3 New boundary string label
- Fields 5 & 6 SPRD for first point to be sent.  
If omitted then the start of string is assumed.
- \* Fields 8 & 9 SPRD for point on string in field 2 generating normal.
- \* Field 10 Sequence number of required intersection of normal with string in field 1.

**Other cases**

There are also the following cases, which are covered by option 010 :

Case 9	From string intersection to string intersection
Case 10	From normal intersection to string intersection
Case 11	From string intersection to normal intersection
Case 12	From normal intersection to normal intersection

## Minor option 010 Create a string (between intersection points)

This option is always used in conjunction with either minor option 008 or 009, and caters specifically for cases 9-12 (see minor option 008 and 009) where the start and end points of the string part are both defined by intersections with other strings. Minor options 008 and 009 don't have enough fields available on their own to hold the input information for these cases.

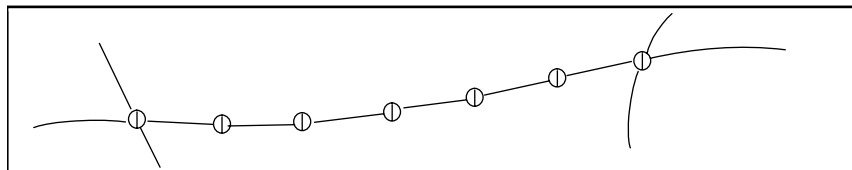
### Linemode

Minor option 008 or 009

- \* Field 3 New string label

Minor option 010

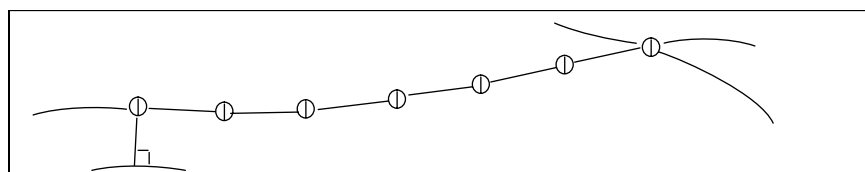
### Case 9 From string intersection to string intersection



**Figure 4 - 27 Example - case 9**

- \* Field 1 Label of string from which points are extracted.
- \* Field 2 Label of first string that intersects string in field 1.
- \* Field 3 Label of second string that intersects string in field 1.
- \* Field 7 Sequence number of required intersection of string in field 1 with string in field 2.
- \* Field 10 Sequence number of required intersection of string in field 1 with string in field 3.

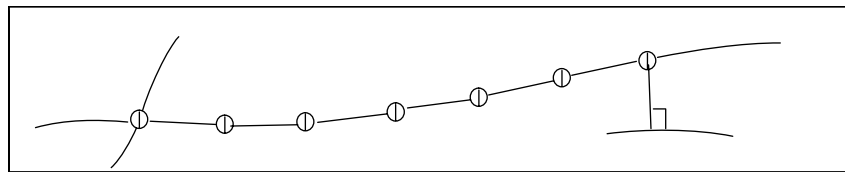
### Case 10 From normal intersection to string intersection



**Figure 4 - 28 Example - case 10**

- \* Field 1 Label of string from which points are extracted.
- \* Field 2 Label of string generating normal.
- \* Field 3 Label of string that intersects string in field 1.
- \* Field 5 & 6 Identification of point on string in field 2 generating normal.
- \* Field 7 Sequence number of intersection of normal with string in field 1.
- \* Field 10 Sequence number of required intersection of string in field 1 with field 3.

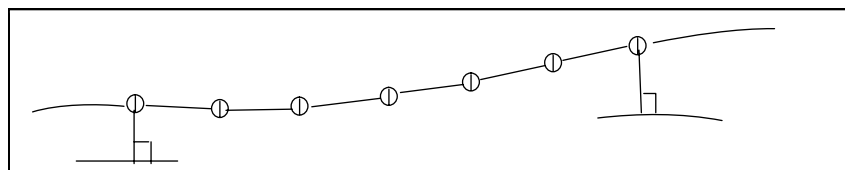
**Case 11 From string intersection to normal intersection**



**Figure 4 - 29 Example - case 11**

- \* Field 1 Label of string from which points are extracted.
- \* Field 2 Label of string that intersects string in field 1.
- \* Field 3 Label of string generating normal.
- \* Field 7 Sequence number of required intersection of string in field 1 with string in field 2.
- \* Field 8 & 9 Identification of point on string in field 3 generating normal.
- \* Field 10 Sequence number of required intersection of normal with string in field 1.

**Case 12 From normal intersection to normal intersection**



**Figure 4 - 30 Example - case 12**

- \* Field 1 Label of string from which points are extracted.
- \* Field 2 Label of string generating the first normal.
- \* Field 3 Label of string generating the second normal.
- \* Field 5 & 6 Identification of point on string in field 2 generating first normal.
- \* Field 7 Sequence number of required intersection of normal with string in field 1.

- \* Field 8 & 9 Identification of point on string in field 3 generating second normal.
- \* Field 10 Sequence number of required intersection of normal with string in field 1.

## Minor option 012 Join two strings

Joins two strings to form a third, or appends one string to another.

### Input

### Graphics

IGEDITT.DAT, EDI002, EDI013

EDIT minor options	Join two strings
Create a string	String label 1
Create a boundary string	String label 2
Create special strings	New string label
Delete an entire string	Contour level
Delete part of a string	
Join two strings	
Add one discontinuity	
Add some discontinuities	
Add comments to input log	
Define system parameters	

**String label 1 and 2:** The first string should be the one whose points are going to be added to the second string. Thus add string 1 to string 2 to create the new string. The second string is also used to dictate the resultant string direction.

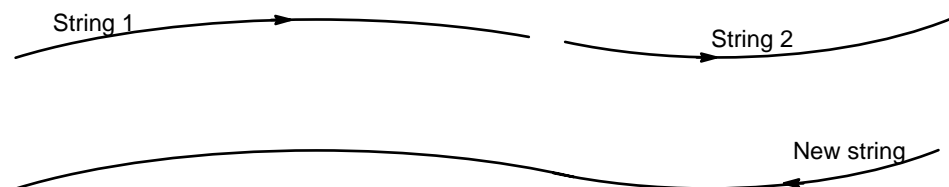
**New string label:** If you do not explicitly give a new string label, string label 2 will be assumed.

**Contour level:** If either of the two strings are two dimensional the resultant string must also be two dimensional. Give the new contour level.

## Linemode

## Minor option 012

- \* Field 1      String label 1
  - \* Field 2      String label 2  
                 This string also governs the resultant string direction
  - Field 3      New string label  
                 If omitted string label 2 will be assumed
  - Field 4      If either string label 1 or string label 2 is two dimensional, then  
                 the new contour level must be given.
- ◇ *Where the strings to be joined are of different dimensions the resultant strings dimension will be the smallest. For example, if one string is 3D and the second is a 6D master string, the resultant string will be 3D.*
  - ◇ *Where the strings to be joined are of more than 3 dimensions, only the first 3 dimensions of each string are reliably carried forward to the new string.*
  - ◇ *Strings with discontinuous bearings should not be joined.*
  - ◇ *The original strings are not automatically deleted.*
  - ◇ *The new string always begins with the points of string label 2. However both ends of the string are considered and string 1 will be joined to string 2 at the closest junction. It may happen that the points of both strings are necessarily reversed.*

**Figure 4 - 31    Example - Join two strings**

If you are uncertain as to the results you will get you may find EDIT option 008 is easier.

## Minor option 020 Change string label / Change contour level

### Input

### Graphics

IGEDITT.DAT, EDI002, EDI016, EDI017

EDIT minor options	Change string label	Change label/subref
Define system parameters	Change label/subref	Reference string
Define string masking	Change 2D level	New sub reference
Change string label		New string label
Change string sub reference		
Change string point		
Add point before a point		
Add point after a point		
Delete a point		
Insert a point		
Convert to 6D M-string		

**Sub reference:** This is usually included automatically by the option that creates the string.

For example, in SECTION the sub reference will indicate the reference string on which the sections are based.

For 2D strings the contour level associated with the string is held in the sub reference.

**IGEDITT.DAT, EDI002, EDI016, EDI018**

<b>EDIT minor options</b>	<b>Change string label</b>	<b>Change 2D level</b>
<b>Define system parameters</b>	<b>Change label/subref</b>	<b>String label</b>
<b>Define string masking</b>	<b>Change 2D level</b>	<b>New contour level</b>
<b>Change string label</b>		
<b>Change string sub reference</b>		
<b>Change string point</b>		
<b>Add point before a point</b>		
<b>Add point after a point</b>		
<b>Delete a point</b>		
<b>Insert a point</b>		
<b>Convert to 6D M-string</b>		

Linemode

Minor option 020

- \* Field 1 Existing label.  
You do not need to give this if you are simply modifying a contour level.
  - Field 2 New sub-reference
  - \* Field 3 New string label.  
If the contour level is being changed type in the contour string label.
  - Field 4 If you are changing the level of a 2D string, give the contour level to be adopted.
  - Field 5 Switch to convert old style section labels (pre-Version 8) to new style section labels.
- ◇ *To change a group of string labels you may find option 030 is more appropriate.*
  - ◇ *Revision of section labels:*
  - ◇ *The labelling convention for section strings allows more than 1000 section strings to be generated along a reference string. The strings are generated using the base 36 algorithm which is used extensively for string relabelling in other MOSS options.*
  - ◇ *To allow users the option of using section strings generated pre-version 8 in existing model files, option 020 has been extended to allow the revision of these labels.*
  - ◇ *Only use 020 to change a string label once; if you change several labels again the situation can become meaningless.*

Example 1

```
020,OLDS,,NEWS
```

This would rename a string called OLDS to NEWS

Example 2

```
020,3 = CONT,26.0
```

This would modify a contour string called CONT to have a level of 26.0.

Example 3

```
020,L,,,,1
```

This would convert old style section labels to new style section labels.

## Minor option 021 Change any string dimension

Use this option to modify the value stored at a string point. For example, you can change the level of a specified point by nominating the string, then identifying the point by any of the current point selection methods, and then



defining the dimension to be changed (in this case dimension 3) and giving the new level.

**Input**

Graphics

IGEDITT.DAT, EDI002, EDI059,EDI019

EDIT minor options	Change string point	Change any string dim.
Define system parameters	Change any string dim.	String to be amended
Define string masking	Change string dim 1/2/3	Point X
Change string label	Change cadastre point	Y
Change string sub reference	Change symbol ref. brg	Dimension number
Change string point		New data value
Add point before a point		
Add point after a point		
Delete a point		
Insert a point		
Convert to 6D M-string		

Linemode

**Change any string dimension**

Minor option 021

- \* Field 3 String label
- \* Field 5 & 6 SPRD of point to be changed
- \* Field 8 Dimension to be changed
- \* Field 9 New data value.

In linemode only it is possible to search for the first point with a particular value in a particular dimension and then change any dimension of this point. If you wish to do this, you should code the option as follows:

**Search and change any string dimension**

Minor option 021

- \* Field 3 String label
- \* Field 4 Dimension to be searched
- \* Field 5 Value to be searched for in the above dimension
- \* Field 8 Dimension to be changed
- \* Field 9 New value to be assigned.

- ◇ *The new data value must be the actual value which will be stored. For this reason, angular data must be in radians.*
- ◇ *It is dangerous to change the values stored in master strings (6D) because the overall geometry of the string may be made inconsistent.*
- ◇ *This option cannot be used to modify the text within a text string.*

## Minor option 022 Change string dimension 1/2/3

Changes any or all of the three dimensions of a string.

### Input

### Graphics

IGEDITT.DAT, EDI002, EDI059,EDI020

EDIT minor options	Change string point	Change string dim. 1/2/3
Define system parameters	Change any string dim.	String to be amended
Define string masking	Change string dim 1/2/3	Chainage / X coord
Change string label	Change cadastre point	Point no. / Y coord
Change string sub reference	Change symbol ref. brg	New X
Change string point		Y
Add point before a point		New Z
Add point after a point		
Delete a point		
Insert a point		
Convert to 6D M-string		

Identify the string and point within it that you want to change using any of the current point selection methods, and then give the new coordinate position.

### Linemode

#### Change string dimension 1/2/3

##### Minor option 022

- \* Field 3 String label
- \* Field 5 & 6 SPRD of point to be changed

Fields 8,9,10 New X,Y,Z values.

In linemode only it is possible to search for the first point with a particular value in one of the first three dimensions and reassign any of these. If you wish to do this, you should code the option as follows:

**Search and change string dimension**

**Minor option 022**

- Field 3       String label
- \* Field 4       Dimension to be searched
- \* Field 5       Value to be searched for in the above dimension
- Field 8       New X value
- Field 9       New Y value
- Field 10      New Z value

◇ *Only the X Y Z values which are to be changed need be given. If you don't give a new value, then the old value will be retained.*

**Minor option 023   Add point before a point**

This option 023 is very similar to option 024/Add a point after a point. In fact you can use either, except at the start of a string when you must use this option.

The point can be :

- a point that is already in another string, or
- a completely new X Y point.

In linemode only, rather than specify SPRD, it is possible to locate the point before which the point is to be added by searching for a particular value in a particular dimension. If you wish to do this, you should code the option as described under 'Using a search'.

**Input**

**Graphics**

IGEDITT.DAT, EDI002, EDI021, EDI022

EDIT minor options	Add point before a point	Add an existing string pt
Define system parameters	Add an existing string pt	String to be amended
Define string masking	Add a new X/Y point	Point X
Change string label		Y
Change string sub reference		Reference string
Change string point		Point X
Add point before a point		Y
Add point after a point		Point Z
Delete a point		
Insert a point		
Convert to 6D M-string		

**IGEDITT.DAT, EDI002, EDI021, EDI023**

EDIT minor options	Add point before a point	Add a new X/Y point
Define system parameters	Add an existing string pt	String to be amended
Define string masking	Add a new X/Y point	Point X
Change string label		Y
Change string sub reference		New X
Change string point		Y
Add point before a point		New Z
Add point after a point		
Delete a point		
Insert a point		
Convert to 6D M-string		

Linemode

**Existing string point**

Minor option 023

Using SPRD:

- \* Field 1      Secondary string label.  
                  This is the string from which the point is to be taken.
- \* Field 3      String label.  
                  This is the string to which the point is to be added.
- \* Field 5 & 6   SPRD of point on string before which the point is to be added.
- \* Field 8 & 9   SPRD of point on secondary string.

Using a search:

- \* Field 1      Secondary string label.  
                  This is the string from which the point is to be taken.
- \* Field 3      String label.  
                  This is the string to which the point is to be added.
- \* Field 4      Dimension to be searched
- \* Field 5      Value to be searched for in the above dimension
- \* Field 8 & 9   SPRD of point on secondary string.

**New XY point**

Minor option 023

Using SPRD:

- \* Field 3      String label
- \* Field 5 & 6   SPRD of point before which the point is to be added

- \* Field 8,9,10 Coordinate of point to be added.  
If field 10 is left blank the level will be set to null. It will not be interpolated.

Using a search:

- \* Field 3 String label.
  - \* Field 4 Dimension to be searched
  - \* Field 5 Value to be searched for in the above dimension
  - \* Field 8,9,10 Coordinate of point to be added.  
If field 10 is left blank the level will be set to null. It will not be interpolated.
- ◇ *After this point is added subsequent point sequence numbers will change.*
  - ◇ *String dimensions above the third are set to zero.*

## Minor option 024 Add point after a point

This option 024 is very similar to option 023/Add a point before a point. In fact you can use either, except at the end of the string when you must use this option.

The point can be:

- a point that is already in another string, or
- a completely new X Y point.

In linemode only, rather than specify SPRD, it is possible to locate the point after which the point is to be added by searching for a particular value in a particular dimension. If you wish to do this, you should code the option as described under 'Using a search'.

Input

Graphics

IGEDITT.DAT, EDI002, EDI024, EDI025

EDIT minor options	Add point after a point	Add an existing string pt
Define system parameters	Add an existing string pt	String to be amended
Define string masking	Add a new X/Y point	Point X
Change string label		Y
Change string sub reference		Reference string
Change string point		Point X
Add point before a point		Y
Add point after a point		Point Z
Delete a point		
Insert a point		
Convert to 6D M-string		

IGEDITT.DAT, EDI002, EDI024, EDI026

EDIT minor options	Add point after a point	Add a new X/Y point
Define system parameters	Add an existing string pt	String to be amended
Define string masking	Add a new X/Y point	Point X
Change string label		Y
Change string sub reference		New X
Change string point		Y
Add point before a point		New Z
Add point after a point		
Delete a point		
Insert a point		
Convert to 6D M-string		

Linemode

Existing string point

Minor option 024

Using SPRD:

- \* Field 1          Secondary string label.  
                         This is the string from which the point is to be taken.

- \* Field 3      String label.  
                  This is the string to which the point is to be added.
- \* Field 5 & 6    SPRD of point on string after which the point is to be added.
- \* Field 8 & 9    SPRD of point on secondary string.

Using a search:

- \* Field 1      Secondary string label.  
                  This is the string from which the point is to be taken.
- \* Field 3      String label.  
                  This is the string to which the point is to be added.
- \* Field 4      Dimension to be searched
- \* Field 5      Value to be searched for in the above dimension
- \* Field 8 & 9    SPRD of point on secondary string.

### **New XY point**

#### **Minor option 024**

Using SPRD:

- \* Field 3      String label
- \* Field 5 & 6    SPRD of point after which the point is to be added
- \* Field 8,9,10   Coordinate of point to be added.  
                  If field 10 is left blank the level will be set to null. It will not be interpolated.

Using a search:

- \* Field 3      String label.
- \* Field 4      Dimension to be searched
- \* Field 5      Value to be searched for in the above dimension
- \* Field 8,9,10   Coordinate of point to be added.  
                  If field 10 is left blank the level will be set to null. It will not be interpolated.

◇ *After this point is added subsequent point sequence numbers will change.*

◇ *String dimensions above the third are set to zero.*

## **Minor option 025    Delete a point**

You can delete a point simply by identifying the string and the point. Although any of the point selection methods may be used to find the point, the point being deleted is an exact point. An exact point is a point actually stored in the string.

In linemode only, rather than specify SPRD, it is possible to locate the point to be deleted by searching for a particular value in a particular dimension. If you wish to do this, you should code the option as described under 'Using a search'.

Input

Graphics

IGEDITT.DAT, EDI002, EDI027

EDIT minor options	Delete a point
Define system parameters	String to be amended
Define string masking	Point X
Change string label	Y
Change string sub reference	
Change string point	
Add point before a point	
Add point after a point	
Delete a point	
Insert a point	
Convert to 6D M-string	

Linemode

Minor option 025

Using SPRD:

- \* Field 3 String label
- \* Field 5 & 6 SPRD of point to be deleted.

Using a search:

- Field 3 String label
- \* Field 4 Dimension to be searched
- \* Field 5 Value to be searched for in the above dimension

- ◇ *By deleting a point the point sequencing will be automatically altered.*
- ◇ *In linemode you should delete points from the highest numbered first. For example, if you are using SPRD and point sequence numbers you should delete points 9, 8, and 7. If you deleted 7, 8, and 9 the points in the original string to disappear would be 7, 9 and 11.*

Minor option 026 Insert a point

026 allows you to insert an extra point into a string by any one of several methods, which fall into two groups:

- Interpolating a point into a string
- Inserting an exact point into a string

We illustrate these in turn.



### Interpolating a point into a string

There are four variations:

- Interpolate a point at a given chainage
- Interpolate a point at the intersection of a normal from an X/Y point
- Interpolate a point at the intersection with the normal from another string
- Interpolate a point at the string's intersection with another string.

### Input

### Graphics

IGEDITT.DAT, EDI002, EDI028, EDI031

<b>EDIT minor options</b>	<b>Insert a point</b>	<b>Interpolate chainage</b>
Define system parameters	Insert existing string pt	String to be amended
Define string masking	Insert existing X/Y point	Chainage
Change string label	Interpolate X/Y point	
Change string sub reference	<b>Interpolate chainage</b>	
Change string point		
Add point before a point		
Add point after a point		
Delete a point		
Insert a point		
Convert to 6D M-string		

IGEDITT.DAT, EDI002, EDI028, EDI030

<b>EDIT minor options</b>	<b>Insert a point</b>	<b>Interpolate X/Y point</b>
Define system parameters	Insert existing string pt	String to be amended
Define string masking	Insert existing X/Y point	Chainage / X coord
Change string label	Interpolate X/Y point	Point no. / Y coord
Change string sub reference	Interpolate chainage	
Change string point		
Add point before a point		
Add point after a point		
Delete a point		
Insert a point		
Convert to 6D M-string		

- ◇ *All the other features as described in line mode for Insert a Point can be achieved using the graphics PSM facility.*

Linemode

In linemode, MOSS deduces which variation you are addressing by the fields into which you have entered data. Hence it is important that you enter your data into the correct field, otherwise it is possible that MOSS will not identify it as an error.

In all cases Field 3 is the label of the string to be amended. The entries for all other fields are as follows.

**Case 1 Insert a point at a given chainage**

- \* Field 5 Chainage of point to be added  
This applies to 6D master strings only

**Case 2 Insert a point at the intersection of a normal from an X/Y coordinate**

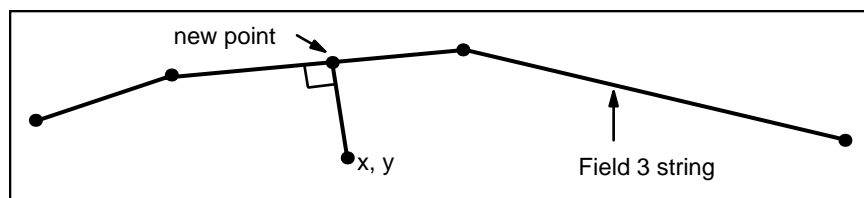


Figure 4 - 32 Example - case 2

- \* Fields 5,6 X and Y co-ordinates

**Case 3 Insert a point at the intersection of a normal from a point on another string**

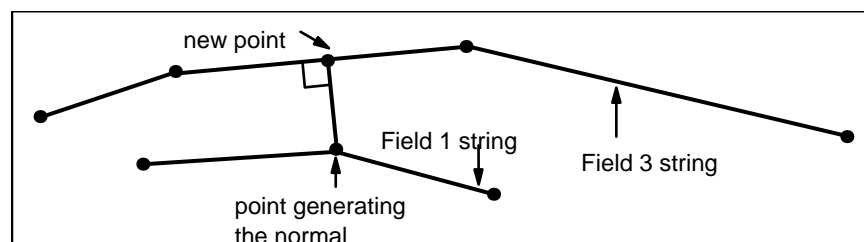
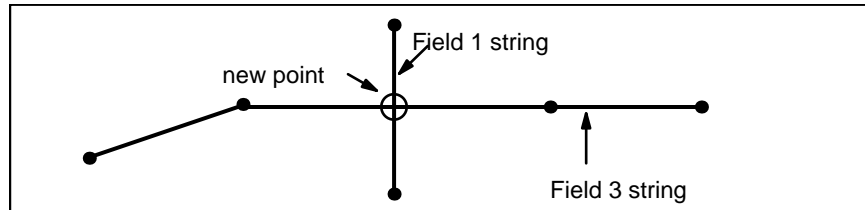


Figure 4 - 33 Example - case 3

- \* Field 1 String containing the point from which the normal is generated
- \* Fields 5,6 SPRD of the point on string 1 generating the normal
- \* Field 7 Sequence number of the intersection of the normal from string 1 with string 3. This field entry is mandatory.

**Case 4 Insert a point at the string's intersection with another string**



**Figure 4 - 34 Example - case 4**

- \* Field 1 String providing intersection
- \* Field 7 Sequence number of required intersection of string in field 3 with string in field 1.

### Inserting an exact point

There are three variations:

- Insert a point which is a string point on another string
- Insert a point by explicitly defining coordinates
- Insert a point which is the intersection of two other strings.

### Input

#### Graphics

IGEDITT.DAT, EDI002, EDI028, EDI029

EDIT minor options	Insert a point	Insert existing string pt
Define system parameters	Insert existing string pt	String to be amended
Define string masking	Insert existing X/Y point	reference string
Change string label	Interpolate X/Y point	Point X
Change string sub reference	Interpolate chainage	Y
Change string point		
Add point before a point		
Add point after a point		
Delete a point		
Insert a point		
Convert to 6D M-string		

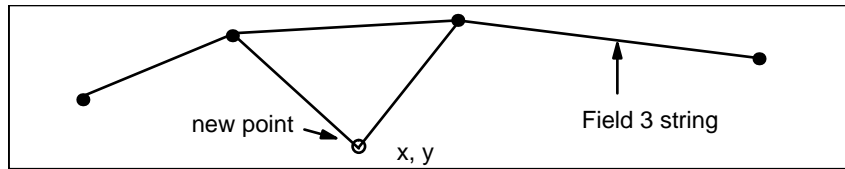
IGEDITT.DAT, EDI002, EDI028, EDI053

EDIT minor options	Insert a point	Insert existing X/Y point
Define system parameters	Insert existing string pt	String to be amended
Define string masking	Insert existing X/Y point	Point X
Change string label	Interpolate X/Y point	Y
Change string sub reference	Interpolate chainage	
Change string point		
Add point before a point		
Add point after a point		
Delete a point		
Insert a point		
Convert to 6D M-string		

Linemode

In all cases Field 3 is the label of the string to be amended.

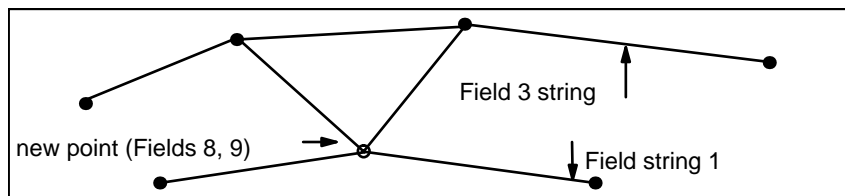
**Case 5 Insert a point by explicitly defining its coordinates**



**Figure 4 - 35 Example - case 5**

- \* Field 5 & 6 SPRD identifying the point after which the point is to be added (optional)
- \* Field 8,9,10 Coordinates of point to be inserted

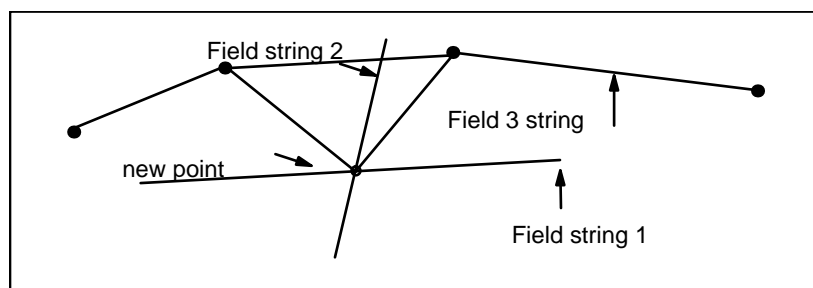
**Case 6 Insert a point which is a string point on another string**



**Figure 4 - 36 Example - case 6**

- \* Field 1 String providing point to be included
- \* Field 5 & 6 SPRD identifying the point after which the point is to be added (optional)
- \* Field 8 & 9 SPRD of point in string 1 to be extracted

**Case 7 Insert a point at the intersection of two other strings**



**Figure 4 - 37 Example - case 7**

- \* Field 1 First string providing intersection
- \* Field 2 Second string providing intersection

- \* Field 5 & 6 SPRD identifying the point after which the point is to be added (optional)
- \* Field 8 & 9 Approximate position of intersection
- \* Field 10 Sequence number of intersection of field 1 with field 2  
Default = 1.0
  - ◇ *If you leave fields 5 and 6 blank, the new point will be inserted before the intersection of a normal from the point defined in fields 8 and 9, with the string to be amended.*
  - ◇ *In linemode, MOSS deduces which variation you are addressing by the fields into which you have entered data. Hence it is important to enter your data into the correct field, otherwise it is possible that MOSS will not identify it as an error.*

## Minor option 027 Convert to 6D M-string

Converts a 3D string to an equivalent 6D master string. This allows you to apply levels to the new string using the vertical design options.

You give the new string label, which must start with M, the subreference of the string is the originating string label. The existing string may be a 3D string, or it may be a 6D master string already. The chainage datum is the chainage attached to the start point (if not given 0.0 will be assumed). The interval defines how frequently you want points included. If you don't give the interval no additional points will be interpolated. The end point you give will usually be the last point but it need not be.

The REGU indicator has been included so that a string may be set up with regular spaced points. The principle application of this is in major option VISUALISE, but other uses may be found.

- ◇ *An M-string created using the REGU indicator does not have the integrity of the existing string from which it is created. M-strings with regular spaced points must not be used for design.*

Input

Graphics

IGEDITT.DAT, EDI002, EDI032

EDIT minor options	Convert to 6D M-string
Insert a point	New M-string label
Convert to 6D M-string	Reference string
Generate curve-fit string	Regular chainage (T)
Define linear units	Chainage datum
Generate M-str from G-str	Start chainage / X coord
Change a series of labels	Start point no. / Y coord
Delete a series of strings	Chainage interval
Delete loops/tail-ends	End chainage / X coord
Add slope signature string	End point no. / Y coord
End EDIT	Chord to arc tolerance

- ◇ You can apply this option to the whole or part of an existing master string to redefine the chainage, and if the direction of the new string is the reverse of the originating master string the point bearings and radii are amended.
- ◇ The chainages for the new string are arc lengths derived from the MOSS curve fitting algorithms.
- ◇ Additional points are added to the string at the regular chainage interval and will supplement the existing points.
- ◇ A report of the new string may show apparent anomalies in the bearings and radius of curvature. This is most likely to occur with converted 3D strings and is due to curvature discontinuities in the string which cannot be detected.

Linemode

Minor option 027

- \* Field 1 Existing string.
- Field 2 Code REGU to obtain regular chainage points only.
- \* Field 3 New M-string label. Initial character must be an M.
- Field 4 Chainage datum. Default 0.0
- Field 5 & 6 SPRD for start point
- Field 7 Chainage interval. If blank no additional points will be added.
- Field 8 & 9 SPRD for end point
- Field 8 & 9 SPRD for end point
- Field 10 Chord-to-arc tolerance  
The default chord-to-arc tolerance is determined by the variable AHDETOLR in the parameter file.

## Minor option 028 Create string with extra points

Creates a string from a reference string with extra points added between each pair of string points. The new string may be a curve fit string or a non-curve fit string.

A curve fit string is one into which additional points have been interpolated to give a smoother curve. The new points are added according to a curve fit algorithm and will not lie on the original string links. The points may be generated to lie on either a MOSS style curve or a SPLINE style generated curve.

A non curve fit string may also be created with extra points added at specified intervals on the original string links.

### Input

### Graphics

IGEDITT.DAT, EDI002, EDI043

EDIT minor options	Create str with extra pts
Insert a point	New string label
Convert to 6D M-string	Reference string
<b>Generate curve-fit string</b>	Method (T)
Define linear units	Tolerance
Generate M-str from G-str	Start chainage / X coord
Change a series of labels	Start point no. / Y coord
Delete a series of strings	End chainage / X coord
Delete loops/tail-ends	End point no. / Y coord
Add slope signature string	
End EDIT	

### Linemode

#### Minor option 028

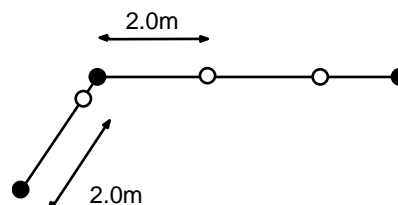
- \* Field 1 Reference string label.  
This is the string from which the new string is to be created.
- Field 2 Interpolation method.
  - MOSS MOSS curve fitting (default).
  - SPLI SPLINE curve fitting
  - DIST Insert points on string links at the distance specified in Field 4. Generally, a short unequal link is left at the end of each original link.



- DIVI      Insert points by dividing the existing string links into equal lengths according to the number of divisions specified in Field 4.
- TOLE      Insert points by halving the existing string links until the distance between the points is less than the tolerance coded in Field 4.
- Field 3    New string label
- Field 3    New string label
- Field 4    Tolerance
- Field 4    Chord-to-arc Tolerance. (default the defue e@@@@ 0.1)  
If Field 2 = MOSS or or S SPLI NE, specify the curve fit chord-to-arc tolerance. This defines the maximum chord-to-arc tolerancedistance between the chord and arc of a curve, which is acceptable before further points are added(. the default chord-to-arc tolerance is determined by the variable AHDETOLR in the parameter file).  
If Field 2 = TOLE, specify the tolerance to be used.  
If Field 2 = DIST, specify the distance between points.  
If Field 2 = DIVI, specify the number of divisions.
- Field 5 & 6    SPRD for start point
- Field 8 & 9    SPRD for end point
- ◇ *All created strings are three-dimensional.*
- ◇ *The new string will be independent of other strings in the model. This means that if two strings are parallel and then curve fitted, they may not be parallel after curve fitting and might even intersect.*
- ◇ *The intersection of curve fit strings may occur with curve fitted contours.*
- ◇ *To achieve a more accurate smoothing of a surface that has been contoured you should use TRIANGLE minor option 963, 'Subdivide triangulation'. See Chapter 10 for further details.*
- ◇ *Groups of strings may be copied and have curve fitting applied using COPY option 064.*

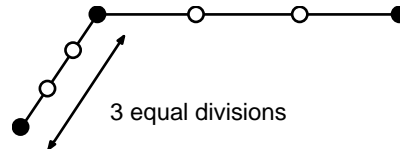
Example

Insert extra points at 2.0m intervals along the string STR1:



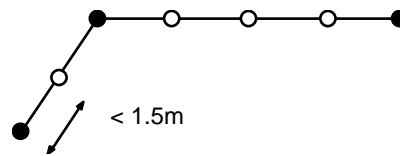
```
EDIT, DESIGN MODEL
028, STR1, DIST, , 2.0
999
```

Insert extra points by dividing each string link of STR1 into 3 parts:



```
EDIT, DESIGN MODEL
028, STR1, DIVI, , 3
999
```

Insert extra points by dividing each string link in half until the distance between points is less than 1.5m:



```
EDIT, DESIGN MODEL
028, STR1, TOLE, , 1.5
999
```

## Minor option 029 Generate M-string from a geometry string

Geometry strings hold the geometric properties of an alignment. The geometric information held includes:

- horizontal tangent points
- horizontal arc centres
- vertical tangent points
- vertical high and low points.

Other geometric information which is calculated from the stored information includes:

- horizontal intersection points
- vertical intersection points

From the data held, transition and other properties may be annotated. It is also possible to derive a 6D M-string from the geometry string, and you can do this to create strings with different chainage intervals.

Input

Graphics

IGEDIT.DAT, EDIT 002, EDI044

EDIT minor options	Generate M-str from G-str
Insert a point	G-string label
Convert to 6D M-string	New M-string label
Generate curve-fit string	Start chainage / X coord
Define linear units	Start point no. / Y coord
Generate M-str from G-str	Chainage interval
Change a series of labels	End chainage / X coord
Delete a series of strings	End point no. / Y coord
Delete loops/tail-ends	Chainage interval trans
Add slope signature string	Chord to arc tolerance
End EDIT	

**G-string label:** indicates the geometry string from which the master string is to be derived.

**New M-string label:** The new string label is derived from the specified geometry string label using the standard naming convention. An initial M is used to indicate that the string is a 6D master string.

**Chainage interval:** This is the chainage interval to be used in the creation of the master string.

If the **start or end chainage** is not given the first or last point of the geometry string will be assumed. If you don't give the **transition chainage interval**, the same chainage interval will be applied throughout.

- ◇ *Points will be generated on the new string at:*
  - *all points at the chainage intervals requested*
  - *all horizontal tangent points between the start and finish chainages*
  - *all vertical tangent points between the start and finish chainages*
  - *any extra points needed to assure the horizontal chord- to- arc tolerance is satisfied*
  - *all high and low points of the vertical alignment.*
- ◇ *Special chainage points can be added using EDIT 026.*
- ◇ *The M-string can be rechained using EDIT 027.*
- ◇ *ALIGNMENT automatically generates a geometry string when a master string is created.*

- ◇ *If the geometry string only contains horizontal information then the resulting string will contain null levels throughout.*
- ◇ *You can use this option to convert any geometry strings, whether the geometry string originated from ALIGNMENT, or from HALGN and/or VALGN.*

### Linemode

#### Minor option 029

- \* Field 1      Geometry string.  
                  This must have an initial character G.
- Field 5      Start chainage of the geometry string.  
                  If blank, the first point of the geometry string will be assumed.
- Field 4      Chord-to-arc tolerance  
                  (the default chord-to-arc tolerance is determined by the variable AHDETOLR in the parameter file.)
- Field 5      Start chainage of the geometry string.  
                  If blank, the first point of the geometry string will be assumed.
- \* Field 7      Chainage interval on straights and arcs.
- Field 8      End chainage of the geometry string.  
                  If blank, the last point of the geometry string will be assumed.
- Field 10     Chainage interval on transitions.  
                  If blank, the interval as given in field 7 will be assumed.

## Minor option 030 Change a series of labels

### Input

### Graphics

IGEDITT.DAT, EDI002, EDI045

EDIT minor options	Change a series of labels
Insert a point	New string label mask
Convert to 6D M-string	Selection mask
Generate curve-fit string	
Define linear units	
Generate M-str from G-str	
Change a series of labels	
Delete a series of strings	
Delete loops/tail-ends	
Add slope signature string	
End EDIT	

Each string in a model may be compared with a simple mask. If the string satisfies the mask then the characters as defined in the renaming mask replace those of the string.

### Linemode

#### Minor option 030

- \* Field 1 Selection mask.  
If all four characters are used then only one string will be selected.
- \* Field 3 Mask containing replacement characters
  - ◇ *Any current masks table set up by 019 will be ignored.*
  - ◇ *For re-labelling single strings, option 020 is more efficient.*

### Example

```
030 ,LX, ,AY
```

This relabels all strings which begin with LX to begin with AY.

## Minor option 031 Delete a series of strings

You can select a set of strings to be deleted by specifying a selection mask.

Input

Graphics

IGEDIT.DAT, EDI002, EDI046

EDIT minor options	Delete a series of strings
Insert a point	Selection mask
Convert to 6D M-string	
Generate curve-fit string	
Define linear units	
Generate M-str from G-str	
Change a series of labels	
Delete a series of strings	
Delete loops/tail-ends	
Add slope signature string	
End EDIT	

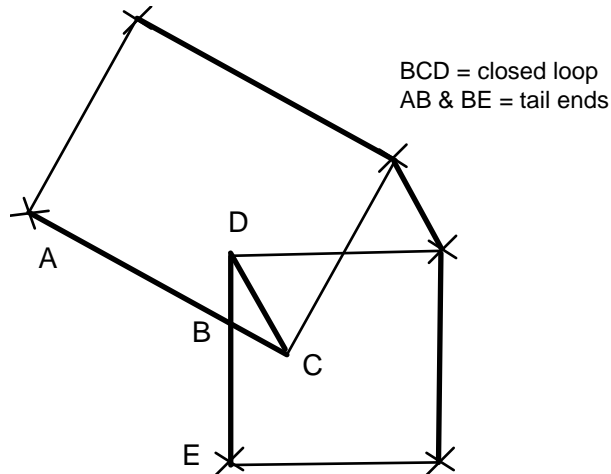
Linemode

Minor option 031

- \* Field 1      Selection mask
  - ◇ *To delete single strings you can use option 004.*
  - ◇ *Any current masks table as set up by option 019 will be ignored.*

Minor option 032    Delete loops / tail ends

In deriving interface strings using major option INTERFACE sometimes the derived string loops back on itself or creates unwanted tail ends, particularly around sharp corners, and particularly at the corners of interface strings.



**Figure 4 - 38 Example - string loops and tail ends**

There are engineering solutions to prevent this happening but it is often convenient simply to identify and remove the loops using a simple EDIT option.

The option identifies the intersections of the string with itself and either removes the points within the closed loop or removes the tail ends. In the drawing above the string ABE would remain if the loops are removed, and string BCD would remain if the tail ends are removed.

**Input**

**Graphics**

**IGEDITT.DAT, EDI002, EDI040, EDI050**

<b>EDIT minor options</b>	<b>Delete loops/tail ends</b>	<b>First string loop</b>
Insert a point	First string loop	String label
Convert to 6D M-string	Intersection number	Curve fitting indicator (T)
Generate curve-fit string	Approximate X/Y coord	Loop indicator
Define linear units	Multiple loops SPRD	
Generate M-str from G-str	Tail-end at intersection	
Change a series of labels	Tail-end at X/Y coord	
Delete a series of strings		
Delete loops/tail-ends		
Add slope signature string		
End EDIT		

**IGEDITT.DAT, EDI002, EDI040, EDI049**

EDIT minor options	Delete loops/tail ends	Intersection number
Insert a point	First string loop	String label
Convert to 6D M-string	Intersection number	Curve fitting indicator (T)
Generate curve-fit string	Approximate X/Y coord	Loop indicator
Define linear units	Multiple loops SPRD	Intersection number
Generate M-str from G-str	Tail-end at intersection	
Change a series of labels	Tail-end at X/Y coord	
Delete a series of strings		
Delete loops/tail-ends		
Add slope signature string		
End EDIT		

**IGEDITT.DAT, EDI002, EDI040, EDI051**

EDIT minor options	Delete loops/tail ends	Approximate X/Y coord
Insert a point	First string loop	String label
Convert to 6D M-string	Intersection number	Curve fitting indicator (T)
Generate curve-fit string	Approximate X/Y coord	Loop indicator
Define linear units	Multiple loops SPRD	Approximate X coord
Generate M-str from G-str	Tail-end at intersection	Approximate Y coord
Change a series of labels	Tail-end at X/Y coord	
Delete a series of strings		
Delete loops/tail-ends		
Add slope signature string		
End EDIT		



**IGEDITT.DAT, EDI002, EDI040, EDI052**

<b>EDIT minor options</b>	<b>Delete loops/tail ends</b>	<b>Multiple loops SPRD</b>
Insert a point	First string loop	String label
Convert to 6D M-string	Intersection number	Curve fitting indicator (T)
Generate curve-fit string	Approximate X/Y coord	Start chainage / X coord
Define linear units	Multiple loops SPRD	Start point no. / Y coord
Generate M-str from G-str	Tail-end at intersection	End chainage / X coord
Change a series of labels	Tail-end at X/Y coord	End point no. / Y coord
Delete a series of strings		
Delete loops/tail-ends		
Add slope signature string		
End EDIT		

**IGEDITT.DAT, EDI002, EDI040, EDI055**

<b>EDIT minor options</b>	<b>Delete loops/tail ends</b>	<b>Tail-end at intersection</b>
Insert a point	First string loop	String label
Convert to 6D M-string	Intersection number	Curve fitting indicator (T)
Generate curve-fit string	Approximate X/Y coord	Loop indicator (T)
Define linear units	Multiple loops SPRD	Intersection number
Generate M-str from G-str	Tail-end at intersection	
Change a series of labels	Tail-end at X/Y coord	
Delete a series of strings		
Delete loops/tail-ends		
Add slope signature string		
End EDIT		

IGEDITT.DAT, EDI002, EDI040, EDI056

EDIT minor options	Delete loops/tail ends	Tail-end at X/Y coord
Insert a point	First string loop	String label
Convert to 6D M-string	Intersection number	Curve fitting indicator (T)
Generate curve-fit string	Approximate X/Y coord	Loop indicator (T)
Define linear units	Multiple loops SPRD	Approximate X coord
Generate M-str from G-str	Tail-end at intersection	Approximate Y coord
Change a series of labels	Tail-end at X/Y coord	
Delete a series of strings		
Delete loops/tail-ends		
Add slope signature string		
End EDIT		

If the single loop indicator is on, a toggle lets you delete only one loop or all loops. For single loop removal you may wish to identify where the loop is (only necessary if there is more than one loop in the string). The position of the loop can be either an approximate coordinate position, or the sequence number of the intersection of the string with itself.

If you are removing a series of loops you can give the range of the string between which the loops are to disappear. Specify the range by start and end points.

- ◇ *In deriving the intersection of the string with itself, the program will use the current curve fitting status to decide whether to curve fit the string or not. Usually you won't want to invoke curve fitting and it can be switched off using option 017.*
- ◇ *At the point of intersection a point will be included in the modified string. The level given to this point is the average of the two levels derived at the intersection.*

Linemode

Minor option 032

- \* Field 3      String label
- Field 4      Single loop indicator.  
                   To remove all loops, leave blank  
                   To remove one loop only, type 1.0  
                   To remove the tail ends, type -1.0 and leave fields 5, 6 and 7 blank.
- ◇ **Beware!** *With field 4 set to -1.0. If field 7 or fields 5 and 6 are filled in then the two parts of the original string before and after the defined intersection will be removed. Hence a single loop remains, with its start and end points equal to the interaction point.*
- Field 5 & 6    Give the start point of the range if all loops are to be removed.

- You can give the approximate point coordinate if only one loop is to be deleted.
- \* Field 7 You can give the intersection point number if only one loop is to be deleted.  
If none of 5,6, or 7 is given the first loop will be deleted.
- Field 8 & 9 If all the loops are to be removed give the end point of the range. By default the last point will be assumed.

### Minor option 033 Change string sub-reference

This minor option allows the sub-reference of a string or set of strings to be modified. The strings may be selected by sub-reference, partial string label or a combination of both.

#### Input

#### Graphics

IGEDITT.DAT, EDI002, EDI057

EDIT minor options	Change string sub-reference
Define system parameters	Label mask
Define string masking	Existing sub-reference
Change string label	New sub-reference
<b>Change string sub reference</b>	
Change string point	
Add point before a point	
Add point after a point	
Delete a point	
Insert a point	
Convert to a 6D M-string	

#### Linemode

##### Minor option 033

- Field 1 Partial string label of string(s) whose sub-references are to be modified.
- Field 2 Existing sub-reference. Partial labels are allowed.
- Field 3 New sub-reference.  
Up to four characters may be used which may include spaces. If this field is blank, the existing sub-references of the specified strings are cleared.

**Example 1**

The following example amends the sub-reference of a set of cross sections with a partial label of 'C' and a sub-reference of 'M001'. The new sub-reference is 'M002'.

```
033 , C , M001 , M002
```

**Example 2**

This example selects all strings with the last two characters 'EN' and sets their sub-references to 'REVD'

```
033 , EN , , REVD
```

**Example 3**

This example selects all strings with the existing sub-reference 'BL' and sets their new sub-reference to 'BL 1'

```
033 , , BL , BL 1
```

**Minor option 035/036 Add slope signature string**

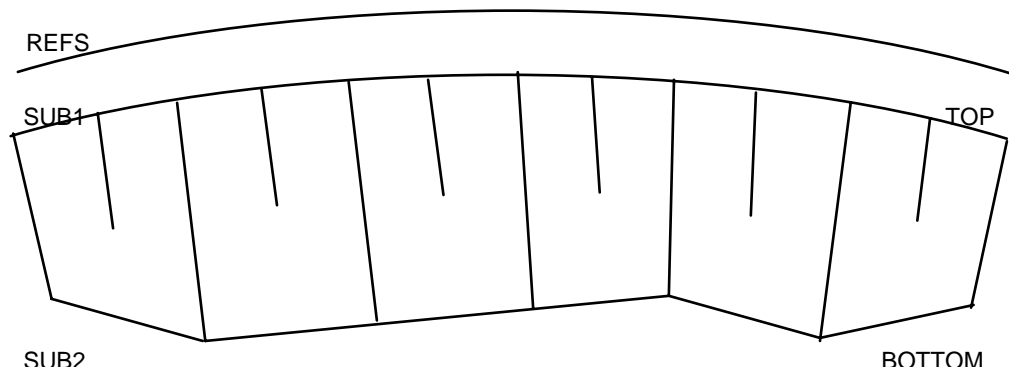
Creates a string relative to two others, representing the slope signature notation between them.

Slope signature, which diagrammatically represents the slope between strings, can be shown in either of two ways within MOSS. The original method, which is now only available when detailed interpretation is used, involves using the DRAW major option to interpret data stored for interface strings only. This produces the original hachure pattern on drawings. However, this representation of the slope is in annotation only and is not stored as a string.

The alternative method, which generates a different pattern from the original hachure, exists as a distinct string in the model. There are three additional advantages:

- Slope signature notation may be produced between strings other than Interface strings
- The string may be drawn directly without using detailed interpretation and symbols
- The slope signature string may be included in the production of perspective views.

This slope signature string consists of a series of straight lines each separated by a discontinuity. The direction of each of the straight lines is normal to the reference string and stretches between the two strings defining the slope. Thus, four strings are involved.



**Figure 4 - 39 Showing slope signature**

Levels are interpolated at all points. This can be used in perspective view, but when extracting cross sections for volumes calculations and so on, you may wish to mask out this type of string.

Where curve fitting is applied, the slope signature string can be placed between strings drawn with different curve characteristics. For example, between a verge string and an interface string it may be best to curve fit the verge string but not the interface strings. If curve fitting is not taken into account there may be gaps between the slope signature string and the bounding strings which will be unacceptable on drawings.

- To draw the slope signature string with tadpoles representing the slope on the long pieces of the string the DRAW minor option 810 would be coded to set the linestyle as follows

```
810,MACR,TADP,OLE,5=-4
```

or in IGMODE set the macro linestyle to TADPOLE and the length of pattern to -4.

Input

Graphics

IGEDIT.DAT, EDI002, EDI033, EDI034

EDIT minor options	Add slope signature string	Add slope signature string
Insert a point	Reference string	New string label
Convert to 6D M-string	Chainage interval	First subsidiary string
Generate curve-fit string	Start chainage / X coord	Second subsidiary string
Define linear units	Start point no. / Y coord	Curve fit 1st string (T)
Generate M-str from G-str	End chainage / X coord	Curve fit 2nd string (T)
Change a series of labels	End point no. / Y coord	
Delete a series of strings		
Delete loops/tail-ends		
Add slope signature string		
End EDIT		

◇ *When the first add slope signature menu is completed, the second menu will be automatically displayed.*

Linemode

Minor option 035

- \* Field 1 Reference string
- \* Field 4 Chainage interval for notation.  
This defines the spacing of the longer lines in the notation. If you leave this blank 10.0 will be used.

Field 5 & 6 SPRD for start of application

Field 8 & 9 SPRD for end of application

The reference string dictates the range of the application and the points within indicate the directions of the slopes. Normally the reference string will be the string from which both the subsidiary strings were designed. On this menu you can also give the chainage interval, and the start and end points, using any of the point selection methods.

Minor option 036

- \* Field 1 First subsidiary string.  
This defines the spacing of the longer lines in the notation.
- \* Field 2 Second subsidiary string
- \* Field 3 New string label
- Field 7 0.0 will suppress curve fitting of the first string.  
1.0 (the default) will invoke curve fitting of the first string.

Field 10      0.0 (the default) will suppress curve fitting of the second string.  
1.0 will invoke curve fitting of the second string.

Note that the default values in fields 7 and 10 are different.

Give the name of the string to be created and the two strings representing the slope. You can elect to curve fit either of these two strings.

◇ *Only strings that represent a surface feature may be used. You will find that 6D master strings, 3D surveyed strings, and designed strings are valid; point strings, volume, test, null and geometry strings are not valid.*

## Minor option 037    Create cadastre string

Creates a cadastre string, or permits additional cadastre points to be added to an existing string. Each cadastre point has a position, feature code, symbol reference bearing, survey point number and cadastre point number.

### Input

### Graphics

IGEDITT.DAT, EDI002A, EDI042, EDI058

EDIT minor options	Create special strings	Create cadastre string
Create a string	Create text string	Cadastre string label
Create a boundary string	Create contour string	Subreference (T)
Create special strings	Create cadastre string	Append indicator (T)
Delete an entire string		X
Delete part of a string		Y
Join two strings		Z
Add one discontinuity		Feature code
Add some discontinuities		Symbol reference bearing
Add comments to input log		Survey point number
Define system parameters		Cadastre point number

### Linemode

#### Minor option 037

- \* Field 1      String label. The string label must begin with 'P'.
- Field 2      Sub-reference.
  - SHEE      defines the rotation datum for the symbol as the left hand sheet edge.
  - NORT      defines the rotation datum for the symbol as true north.

- Field 3      Append indicator.  
APP      append to existing string.  
If left blank, a new string is created.
- Field 7      Symbol reference bearing - real number (default angular units)
- \* Field 8      X coordinate.
- \* Field 9      Y coordinate.
- Field 10     Z coordinate.  
If left blank, a null level is stored.

Each 037 option may be followed by a supplementary information 001 option.

**Minor option 001**

- Cols 4-11    Survey point number (8 digits integer)
- Cols 12-15   Feature code (4 alphanumeric characters).
- Cols 16-31   Cadastral point number (16 alphanumeric characters).

**Minor option 038    Change cadastre point**

This option permits you to amend a cadastre point by changing its position, feature code, symbol reference bearing, survey point number or cadastre point number.

**Input**

**Graphics**

IGEDITT.DAT, EDI002AB, EDI059, EDI060

EDIT minor options	Change string point	Change cadastre point
Define system parameters	Change any string dim.	Cadastre string label
Define string masking	Change string dim. 1/2/3	Subreference (R)
Change string label	Change cadastre string	Point to be amended
Change string sub reference	Change cadastre ref.brg	New X
Change string point		New Y
Add point before a point		New Z
Add point after a point		Feature code
Delete a point		Symbol reference bearing
Insert a point		Survey point number
Convert to 6D M-string		Cadastre point number

◇ *This option can only change cadastre point information for cadastre symbols created using the DRAW option 856.*



Linemode

Minor option 038

- Field 1 Cadastre string label. The string label must begin with 'P'.
- Field 6 Point to be amended.
- Field 7 Symbol reference bearing.
- Field 8 New X coordinate.
- Field 9 New Y coordinate.
- Field 10 New Z coordinate.

Each 038 option may be followed by a supplementary information 001 option.

Minor option 001

- Cols 4-11 Survey point number (8 digits integer)
- Cols 12-15 Feature code (4 alphanumeric characters).
- Cols 16-31 Cadastral point number (16 alphanumeric characters).

### Change symbol reference bearing

This option permits you to change the symbol reference bearing at any point on a cadastre string.

#### Input

#### Graphics

IGEDITT.DAT, EDI002B, EDI059, EDI061

EDIT minor options	Change string point	Change cadastre ref. brg.
Define system parameters	Change any string dim	Cadastre string label
Define string masking	Change string dim 1/2/3	Subreference (R)
Change string label	Change cadastre string	Point to be amended
Change string sub reference	Change cadastre ref. brg.	Rotate clockwise
Change string point		Rotate anti-clockwise
Add point before a point		Angular increment
Add point after a point		Bearing
Delete a point		
Insert a point		
Convert to 6D M-string		

**Cadastre string label** is the label of the cadastre string containing the symbol to be rotated.

**Subreference** is read only information. It shows the rotation axis datum as either SHEE (the left hand sheet edge) or NORT (true north).

**Point to be amended** is the point on the cadastre string where the symbol is located.

**Rotate clockwise** rotates the symbol by the angular increment in a clockwise direction. The rotation is measured between the rotation axis datum and the y-axis of the symbol.

**Rotate anticlockwise** rotates the symbol by the angular increment in an anticlockwise direction. The rotation is measured between the rotation axis datum and the y-axis of the symbol.

**Angular increment** is the number of angular units by which the symbol is rotated.

**Bearing** is the angle between the y-axis of the symbol and the rotation axis datum.

# Major option REPORT

REPORT gives general information about all the models on your model file, and also gives information from within the models.

REPORT provides:

- Instantaneous analysis of points and strings
- Geometric calculations
- Modelfile analysis
- Listings of strings and associated information

REPORT is often used to confirm that design tasks have been completed successfully.

The REPORT minor options are:

980	Report geometry information
982	Report of triangles
984	Report Piste format information
985/986	Report section strings in a stylised format
985/983	Report section strings in a stylised (Piste) format
987	Check record pointers
988	Check for loops in string
989	Model file records used
990	Models
991	Strings
992	String details
993	Report the points on a string in user defined format
994	Section strings
995	Distance and bearing (of line)
996	Distance and bearing (of normal)
997	Intersections of 2 strings
998	Normal intersections

- ◇ *In graphics the scrolling menus lead you through the detailed options of REPORT, but for simple analyses you may find STATUS in the static menu area more effective than REPORT.*

## Access to major option REPORT

### Input

### Graphics

Major option REPORT is available in several graphics option menus.

GEN001, REP001

	REPORT model requirements
	Model to be reported
	Reference model (optional)
REPORT	

### Linemode

REPORT options all follow the standard minor option format:

Major option REPORT

Model 1      Contains the model from which information is to be reported.

Model 2      Second model (if it needs to be referenced).

- ◇ *Leave Model 1 blank if you are not accessing strings; for example, it is unnecessary for options 987, 989, 990.*
- ◇ *When you report some models you may find the model name is extended by four characters. These four characters are set automatically and indicate the model type and hence the information held within it.*

## Global minor options

Global options 000, 001, 003, 017, 018, 019, 900 may all be used in REPORT.

## Minor option 980      Geometry information

Minor option 980 will report geometry string information using the extended set of geometry codes available. Refer to Major option DRAW, minor option 809 for more information on geometry strings.

Input

Graphics

REP002, REP021

REPORT minor options	Geometry string details
Add comments to input log	Select label/mask
Define system parameters	Start chainage / X coord
Define linear units	Start point no / Y coord
Define string masking	End chainage / X coord
Models	End point no / Y coord
Strings	HTPS (T)
String details	HIPS (T)
Geometry string details	HCEN (T)
Section strings	VTPS (T)
Distance and bearing	VIPS (T)
	VFPS (T)
	VMOS (T)
	SUPE (T)
	CANT (T)
	RAIL (T)

Linemode

Minor option 980

Field 1 String label (must be a geometry string)

Field 2 Geometry string code

- ALL All geometry string points
- HTPS Horizontal tangent points
- HIPS Horizontal intersection points
- HCEN Horizontal arc centres
- VTPS Vertical tangent points
- VIPS Vertical intersection points
- VFPS Vertical flat points
- VMOS Vertical mid-ordinate points
- SUPE Superelevation points
- CANT Cant at HTPS
- RAIL Railway geometry points

Field 5,6 SPRD for first point in the string to be reported

Field 8,9 SPRD for last point in the string to be reported

- ◇ *If nothing is selected in Field 2, the default setting of ALL will be used.*
- ◇ *Refer to User Manual, Chapter 3, Figure 3-96 for a pictorial representation of SUPE and CANT options and Chapter 6, Railways for a description of Railway geometry points.*

- ◇ *The deflection angles reported are always positive and may therefore be greater than 180°.*

Example

```

1) 980,2=ALL (All geometry string points)
GAS4   MAS4   777712   34   1064   1086   1767   1980   527   1

POINT  ---X-----  ---Y-----  ---Z-----  ---C-----  ---B-----  ---R-----  ---G-----  -M-VALUE-  HCOD  VCOD  HNAM  VNAM
1      1064.828   1086.805   30.000      0.000   1 45 39.2   300.000   0.02959   0.00000  PBC   PBT   A001  B001
2      1124.283   1257.048   35.420     183.158  36 44 29.4   300.000   0.02959  -1.50000  PC    PC    A001  B002
3      1159.921   1296.839   36.789     236.645  46 57 24.6   300.000   0.02157  -1.50000  CS00  A001
4      1185.684   1317.948   37.424     269.979  54 54 52.5   200.000   0.01657  -1.50000  SC00  A002
5      1288.649   1353.928   38.340     380.448  86 33 42.1   200.000   0.00000  -1.50000  VX    B002
6      1332.178   1351.787   38.197     424.116  99 4 18.1    200.000  -0.00655  -1.50000  CS00  A002
7      1426.679   1319.941   36.791     524.116 113 23 44.3  INFINITY -0.02155  -1.50000  ST00  A003
8      1474.335   1299.322   35.470     576.042 113 23 44.3  INFINITY -0.02934  -21.14639 PCC   B003
9      1518.457   1280.233   31.616     624.116 113 23 44.3  INFINITY -0.13100  -21.14639 TS00  A003
10     1561.580    1263.186   23.264     670.505 107 54 56.8  -242.514  -0.22909  27.03161 PRC   B004
11     1589.333    1256.348   17.816     699.116 99 4 18.1    -150.000 -0.15175  27.03161 SC00  A004
12     1636.510    1256.328   13.660     746.490 80 58 34.4  -150.000 -0.02369  27.03161 VM   B004
13     1645.122    1257.955   13.556     755.256 77 37 40.8  -150.000 0.00000  27.03161 VX   B004
14     1705.431    1286.347   19.663     822.475 51 57 7.8   -150.000 0.18170  -11.84929 PRC   B005
15     1755.099    1356.483   31.000     909.637 18 39 30.6  -150.000 0.07842  -11.84929 CS00  A004
16     1764.030    1398.886   33.288     953.051 6 39 22.1   -335.144  0.02698  -11.84929 VM   B005
17     1766.066    1421.563   33.595     975.821 4 1 24.5   -950.425  0.00000  -11.84929 VX   B005
18     1766.504    1428.057   33.570     982.330 3 44 2.5  -2000.000 -0.00771  -11.84929 SS00  A004
19     1764.499    1500.506   29.879    1055.022 348 48 34.5  -150.000 -0.09385  -11.84929 SC00  A005
20     1756.314    1527.870   26.709    1083.627 337 52 59.7  -150.000 -0.12774  15.38059 PRC   B006
21     1738.403    1559.976   23.046    1120.485 323 48 16.9  -150.000 -0.07105  15.38059 VM   B006
22     1735.195    1564.201   22.690    1125.789 321 46 42.5  -150.000 -0.06289  15.38059 CS00  A005
23     1713.590    1587.151   21.472    1157.342 312 39 19.1  -291.852  -0.01436  0.00000  PT    B007
24     1688.212    1608.805   20.992    1190.707 309 22 48.7  INFINITY -0.01436  0.00000  SS00  A005
25     1670.600    1623.529   20.662    1213.665 310 55 51.3  424.165  -0.01436  3.38586  PC    B008
26     1641.229    1653.408   20.358    1255.626 321 46 43.8  150.000  -0.00016  3.38586  SC00  A006
27     1640.942    1653.773   20.358    1256.090 321 57 22.7  150.000  0.00000  3.38586  VX   B008
28     1609.218    1752.781   22.266    1362.259 2 30 35.2   150.000  0.03595  3.38586  VM   B008
29     1610.499    1766.845   22.808    1376.386 7 54 21.5   -200.000 0.04073  3.38586  PRC   A007
30     1584.521    1896.211   31.346    1510.853 329 23 3.2   -200.000 0.08626  -5.96894 PRC   B009
31     1534.689    1952.613   36.166    1586.567 307 41 38.1  -150.000 0.04107  -5.96894 PCC   A008
32     1496.328    1974.109   37.397    1630.698 290 50 11.8  -150.000 0.01472  -5.96894 VM   B009
33     1472.657    1980.952   37.578    1655.366 281 24 50.9  -150.000 0.00000  -5.96894 VX   B009
34     1379.720    1969.930   34.875    1750.544 245 3 32.6   -150.000 -0.05681  -5.96894 PAC  PAC  A008  B009
  
```

```

2) 980,2=HIPS (Horizontal Intersection Points)
GAS4   MAS4   777712   8   1064   1086   1767   1980   527   1

---X-----  ---Y-----  --Deflection Ang--  ---R-----  HCOD  HNAM
1064.828   1086.805   1 45 39.2         300.000  HIP   A001
1185.684   1317.948   54 54 52.5       200.000  HIP   A002
1589.333   1256.348   99 4 18.1        -150.000 HIP   A004
1766.504   1428.057   3 44 2.5         -2000.000 HIP   A004
1735.195   1564.201   321 46 42.5      -350.000  HIP   A005
1641.229   1653.408   321 46 43.8      450.000  HIP   A006
1610.499   1766.845   7 54 21.5        -200.000 HIP   A007
1379.720   1969.930   245 3 32.6      -150.000 HIP   A008
  
```

```

3) 980,2=HTPS (Horizontal Tangent Points)
GAS4   MAS4   777712   16  1064   1086   1767   1980   527   1

---X-----  ---Y-----  ---Z-----  ---C-----  ---B-----  ---R-----  ---G-----  -M-VALUE-  HCOD  HNAM  POINT
1      1064.828   1086.805   30.000      0.000   1 45 39.2   300.000   0.02959   0.00000  PBC   PBT   A001  A001
3      1159.921   1296.839   36.789     236.645  46 57 24.6   300.000   0.02157  -1.50000  CS00  A001
4      1185.684   1317.948   37.424     269.979  54 54 52.5   200.000   0.01657  -1.50000  SC00  A002
6      1332.178   1351.787   38.197     424.116  99 4 18.1    200.000  -0.00655  -1.50000  CS00  A002
7      1426.679   1319.941   36.791     524.116 113 23 44.3  INFINITY -0.02155  -1.50000  ST00  A003
9      1518.457   1280.233   31.616     624.116 113 23 44.3  INFINITY -0.13100  -21.14639 TS00  A003
11     1589.333    1256.348   17.816     699.116 99 4 18.1    -150.000 -0.15175  27.03161 SC00  A004
15     1755.099    1356.483   31.000     909.637 18 39 30.6  -150.000 0.07842  -11.84929 CS00  A004
18     1766.504    1428.057   33.570     982.330 3 44 2.5  -2000.000 -0.00771  -11.84929 SS00  A004
19     1764.499    1500.506   29.879    1055.022 348 48 34.5  -150.000 -0.09385  -11.84929 SC00  A005
22     1735.195    1564.201   22.690    1125.789 321 46 42.5  -150.000 -0.06289  15.38059 CS00  A005
24     1688.212    1608.805   20.992    1190.707 309 22 48.7  INFINITY -0.01436  0.00000  SS00  A005
26     1641.229    1653.408   20.358    1255.626 321 46 43.8  150.000  -0.00016  3.38586  SC00  A006
29     1610.499    1766.845   22.808    1376.386 7 54 21.5   -200.000 0.04073  3.38586  PRC   A007
31     1534.689    1952.613   36.166    1586.567 307 41 38.1  -150.000 0.04107  -5.96894 PCC   A008
34     1379.720    1969.930   34.875    1750.544 245 3 32.6   -150.000 -0.05681  -5.96894 PAC  PAC  A008  A008
  
```

```

4) 980,2=HCEN (Horizontal Arc Centres)
GAS4   MAS4   777712   4   1064   1086   1767   1980   527   1

---X-----  ---Y-----  ---R-----  HCOD  HNAM
1364.828   1186.000   150.000  HCEN  A001
1259.921   1096.839  -300.000 HCEN  A002
1085.684   1217.948  -200.000 HCEN  A005
1532.178   1551.787   500.000 HCEN  A009
  
```

```

5) 980,2=VIPS (Vertical Intersection Points)
GAS4   MAS4   777712   4   1064   1086   1767   1980   527   1

---X-----  ---Y-----  ---Z-----  ---C-----  --Grad Diff--  --Vert R--  --M Value--  VCOD
1064.828   1086.805   30.000      0.000   1 45 39.2   10000.000  1.000  VIP
1185.684   1317.948   37.424     123.432  54 54 52.5  -7500.000  -1.333  VIP
1589.333   1256.348   17.816     187.965  99 4 18.1   15000.000  0.666  VIP
1766.504   1428.057   33.570     201.123  3 44 2.5   -6000.000  -1.667  VIP
  
```

```

6) 980,2=VTPS (Vertical Tangent Points)
GAS4   MAS4   777712   34  1064   1086   1767   1980   527   1

POINT  ---X-----  ---Y-----  ---Z-----  ---C-----  ---G-----  --Vert R--  -M-VALUE-  VCOD  VNAM
  
```

1	1064.828	1086.805	30.000	0.000	0.02959	INFINITY	0.00000	PBT	B001		
2	1124.283	1257.048	35.420	183.158	0.02959	-6666.667	-1.50000	PC	B002		
8	1474.335	1299.322	35.470	576.042	-0.02934	-472.894	-21.14639	PCC	B003		
10	1561.580	1263.186	23.264	670.505	-0.22909	369.937	27.03161	PRC	B004		
14	1705.431	1286.347	19.663	822.475	0.18170	-843.932	-11.84929	PRC	B005		
20	1756.314	1527.870	26.709	1083.627	-0.12774	650.170	15.38059	PRC	B006		
23	1713.590	1587.151	21.472	1157.342	-0.01436	INFINITY	0.00000	PT	B007		
25	1670.600	1623.529	20.662	1213.665	-0.01436	2953.459	3.38586	PC	B008		
30	1584.521	1896.211	31.346	1510.853	0.08626	-1675.339	-5.96894	PRC	B009		
34	1379.720	1969.930	34.875	1750.544	-0.05681	-1675.339	-5.96894	PAC	B009		
7) 980=VFPS (Vertical Flat Points)											
GAS4	MAS4	777712	5	1064	1086	1767	1980	527	1		
POINT	---X---	---Y---	---Z---	---C---	---Vert R---	---M-VALUE---	VCOD	VNAM			
5	1288.649	1353.928	38.340	380.448	-6666.667	-1.50000	VFPK	B002			
13	1645.122	1257.955	13.556	755.256	369.937	27.03161	VFTR	B004			
17	1766.066	1421.563	33.595	975.821	-843.932	-11.84929	VFPK	B005			
27	1640.942	1653.773	20.358	1256.090	2953.459	3.38586	VFTR	B008			
33	1472.657	1980.952	37.578	1655.366	-1675.339	-5.96894	VFPK	B009			
8) 980=VMOS (Vertical Mid-Ordinate Points)											
GAS4	MAS4	777712	5	1064	1086	1767	1980	527	1		
POINT	---X---	---Y---	---Z---	---C---	---G---	---Vert R---	---M-VALUE---	VCOD	VNAM		
12	1636.510	1256.328	13.660	746.490	-0.02369	369.937	27.03161	VMOS	B004		
16	1764.030	1398.886	33.288	953.051	0.02698	-843.932	-11.84929	VMOS	B005		
21	1738.403	1559.976	23.046	1120.485	-0.07105	649.946	15.38059	VMOS	B006		
28	1609.218	1752.781	22.266	1362.259	0.03595	2953.459	3.38586	VMOS	B008		
32	1496.328	1974.109	37.397	1630.698	0.01472	1675.339	-5.96894	VMOS	B009		
7) 980=SUPE (Crossfall Points)											
LABEL	SUBREF	CONTENTS	NO.PTS	X -MIN	Y -MIN	X -MAX	Y -MAX	RECORD	LOC.		
GLLL	MLLL	777712	3	4106	8355	4487	8890	36	1		
POINT	---X---	---Y---	---Z---	---C---	---B---	---R---	---SUPER---	---DESIGN	SPEED	HCOD	
1	4106.476	8355.048	-999.000	0.000	27 43 15.3	INFINITY	0.02500	100.00000	XF00		
2	4276.852	8679.279	-999.000	366.269	27 43 15.3	500.000	0.07000	100.00000	XF00		
3	4486.435	8889.073	-999.000	667.342	62 13 16.9	500.000	0.07000	100.00000	XF00		
8) 980=CANT (Cant Points)											
LABEL	SUBREF	CONTENTS	NO.PTS	X -MIN	Y -MIN	X -MAX	Y -MAX	RECORD	LOC.		
GFFF	MFFF	777712	3	4149	8341	4548	8845	40	1		
POINT	---X---	---Y---	---Z---	---C---	---B---	---R---	---CANT---	---DESIGN	SPEED-	HCOD	
1	4149.156	8341.515	-999.000	0.000	63 46 24.3	-501.000	0.15000	80.00000	CA00		
2	4355.043	8529.358	-999.000	282.425	31 28 28.1	INFINITY	0.00000	90.00000	CA00		
3	4547.854	8844.311	-999.000	651.710	31 28 28.1	INFINITY	0.00000	90.00000	CA00		
9) 980=RAIL (Railway Geometry points)											
GAAA	MAAA	777712	8	4142	8338	4574	8880	71	1		
POINT	---X---	---Y---	---Z---	---C---	---B---	---R---	HCOD	---LABEL---	HNAM	---COMP	LABEL-
2	4177.048	8442.577	-999.000	109.712	21 51 0.8	2300.000	M1	MPUR	AA01	SW01	
3	4191.542	8476.561	-999.000	146.661	24 20 53.2	2300.000	M2	MPUR	AA01	SW01	
4	4219.333	8532.405	-999.000	209.052	28 33 57.6	2300.000	M3	MPUR	AA01	SW01	
5	4415.409	8773.434	-999.000	521.528	49 41 26.3	2300.000	M1	MPUR	AA02	SW01	
6	4464.428	8812.008	-999.000	583.919	53 54 30.7	2300.000	M2	MPUR	AA02	SW01	
7	4494.751	8833.117	-999.000	620.868	56 24 23.1	2300.000	M3	MPUR	AA02	SW01	
LABEL	SUBREF	CONTENTS	NO.PTS	X -MIN	Y -MIN	X -MAX	Y -MAX	RECORD	LOC.		
GPUR	MPUR	777712	14	4177	8442	4495	8834	76	1		
POINT	---X---	---Y---	---Z---	---C---	---B---	---R---	HCOD	---LABEL---	HNAM	---COMP	LABEL-
2	4177.048	8442.577	-999.000	0.000	21 51 0.8	2300.000	S0	MAAA	AA01	SW01	
4	4180.115	8450.228	-999.000	8.243	21 51 0.8	2300.000	S1	MAAA	AA01	SW01	
5	4191.229	8476.859	-999.000	37.101	23 27 12.3	2300.000	S2	MAAA	AA01	SW01	
6	4217.742	8533.242	-999.000	99.416	26 54 55.0	2300.000	S3	MAAA	AA01	SW01	
9	4414.266	8774.821	-999.000	414.073	51 20 28.9	2300.000	S1	MAAA	AA02	SW01	
10	4464.073	8812.255	-999.000	476.388	54 48 11.6	2300.000	S2	MAAA	AA02	SW01	
12	4487.885	8828.556	-999.000	505.246	56 24 23.1	2300.000	S3	MAAA	AA02	SW01	
14	4494.751	8833.117	-999.000	513.489	56 24 23.1	2300.000	S4	MAAA	AA02	SW01	

## Minor option 982 Triangles

Minor option 982 will report triangle information from models created using major option TRIANGLE.



Input

Graphics

REP002, REP020

REPORT minor options	Traingle information
Distance and bearing	Triangulation label
Intersection of 2 strings	Report style 1,2,3,4 (T)
Normal intersections	X coordinate
Triangles	Y coordinate
Check record pointers	
Check for loops in string	
Piste format information	
Model file records used	
End REPORT	

Linemode

Minor option 982

- \* Field 1 Required triangulation string label
- Field 4 Code 1 will output level of a given point and the triangle associated with it.  
Code 2 will output information for a single triangle for a given point.  
Code 3 will output coordinates of centroid and vertices for all triangles.  
Code 4 will list allocated triangle group codes.
- \* Field 5 X coordinate of given point
- \* Field 6 Y coordinate of given point
- ◇ *If field 4 = 1 or 2, then the given point coordinates must be coded in field 5 and 6.*

Example

```

MOSS
REPORT,SIMPLE DESIGN TRIANG
982,TRIM,4=1,501287.667,111185.210
982,TRIM,4=2,501287.667,111185.210
982,TRIM,4=3
999

MOSS

REPORT SIMPLE DESIGN TRIANG
W147 CURVE FITTING INVOKED

----- M O D E L   N A M E ----- RECORD   SECURITY   DATE LAST USED -----
SIMPLE DESIGN TRIANG          TRIA          24         FREE          22JAN91

982TRIM                        1501287.667111185.210

TRIANGLE NUMBER                837
POINT CO-ORDINATES             501287.667      111185.210      66.096

982TRIM                        2501287.667111185.210

TRIANGLE NUMBER                837
TRIANGLE CENTROID              501288.576      111184.988      66.117
CO-ORDINATES VERTEX 1         501292.977      111187.729      66.890
CO-ORDINATES VERTEX 2         501288.373      111179.867      65.200
CO-ORDINATES VERTEX 3         501284.379      111187.367      66.260
TRIANGLE AREA                  32.970
TRIANGLE ASPECT                3.499
TRIANGLE SLOPE                 0.188

982TRIM                        3

TRIANGLE NUMBER                1
TRIANGLE CENTROID              501499.462      111266.238      52.573
CO-ORDINATES VERTEX 1         501499.548      111265.453      52.530
CO-ORDINATES VERTEX 2         501496.089      111274.094      53.710
CO-ORDINATES VERTEX 3         501502.749      111259.167      51.480
ADJACENT TRIANGLES            439              63              1058

TRIANGLE NUMBER                2
TRIANGLE CENTROID              501037.705      110933.989      -999.900
CO-ORDINATES VERTEX 1         500704.351      110561.039      -999.900
CO-ORDINATES VERTEX 2         501204.351      111120.606      -999.900
CO-ORDINATES VERTEX 3         501204.412      111120.323      -999.900
ADJACENT TRIANGLES            1515              305              227

TRIANGLE NUMBER                3
TRIANGLE CENTROID              501330.620      111241.872      66.427
CO-ORDINATES VERTEX 1         501262.208      111232.434      70.480
CO-ORDINATES VERTEX 2         501369.138      111248.129      64.150
CO-ORDINATES VERTEX 3         501360.515      111245.054      64.650
ADJACENT TRIANGLES            337              917              317

TRIANGLE NUMBER                4
TRIANGLE CENTROID              501511.212      111244.239      48.611
CO-ORDINATES VERTEX 1         501506.809      111250.764      50.000
CO-ORDINATES VERTEX 2         501517.205      111237.194      47.093
CO-ORDINATES VERTEX 3         501509.623      111244.760      48.740
ADJACENT TRIANGLES            1053              1120              1021

TRIANGLE NUMBER                5
TRIANGLE CENTROID              501379.557      111173.703      56.564
CO-ORDINATES VERTEX 1         501375.754      111174.110      56.763
CO-ORDINATES VERTEX 2         501386.031      111175.525      56.118
CO-ORDINATES VERTEX 3         501376.888      111171.473      56.811
ADJACENT TRIANGLES            121              256              128

TRIANGLE NUMBER                6
TRIANGLE CENTROID              501655.487      110965.376      -999.900
CO-ORDINATES VERTEX 1         501478.776      111169.188      -999.900

```

Minor option 984 Piste format information

In France a standard style of printed output is used extensively, known as PISTE format. There are two styles for tabulating the horizontal alignment details in PISTE format, and two styles for tabulating the vertical alignment details. These four styles are shown on the following pages and may be summarised as:

- Style 1: Horizontal geometry showing curve centres.
- Style 2: Horizontal digital points showing section bearings.

- Style 3: Longitudinal profile (Part 1)
- Style 4: Longitudinal profile (Part 2, showing curve parameters).

**Input**

Graphics

REP002, REP018

REPORT minor options	Piste format information
Distance and bearing	Label of G-string
Distance & brg (normal)	Report style 1,2,3,4 (T)
Intersection of 2 strings	Start chainage / X coord
Normal intersections	Start point no. / Y coord
Triangles	End chainage / X coord
Check record pointers	End point no. / Y coord
Check for loops in string	
Piste format information	
Model file records used	
End REPORT	

Linemode

Major option REPORT

Model 1 Model containing the geometry string.

Model 2 Model containing the digital master alignment string.

Minor option 984

\* Field 1 Geometry string label. Must commence with letter G.

Field 4 Style of output:

- 1 Style 1
- 2 Style 2
- 3 Style 3
- 4 Style 4

Field 5,6 SPRD for first point in the string to be reported

Field 8,9 SPRD for last point in the string to be reported

Example

```
REPORT, FRENCH HAL ELE, FRENCH HAL
984, GAST, 4=1
984, GAST, 4=2, 6=2, 9=30
984, GAST, 4=3
984, GAST, 4=4, 6=10, 9=30
999
```

Output

Report Style 1

```

MOSS>REPO THORNBROUGH NOUVEAUX
REPO THORNBROUGH NOUVEAUX
W147 CURVE FITTING INVOKED

----- M O D E L   N A M E ----- RECORD SECURITY DATE LAST USED -----
THORNBROUGH NOUVEAUX                2976   FREE      28JAN91

REPO>984,G006,4=1
984G006                               1
                                     AXE EN PLAN

NOM      -CARACTERISTIQUES-- -LONGUEUR-  -ABSCISSE-  -----X----- -----Y-----
-----
1      TETA =      68.91096   298.094
-----
1      XC =      3382.53627   156.799
      YC =      30179.93516
      R =      -583.430
-----
2      XC =      3659.96171   545.108
      YC =      29886.34605
      R =      -179.500
-----
                                     454.892   3783.24512   29755.87977
-----
                                     1000.000   3550.99984   30028.99093
-----
                                     LONGUEUR DE L'AXE   1000.000
    
```

Report Style 2

```

REPO>984,G006,4=2,8=300
984G006                               2                               300
                                     PROFILS EN TRAVERS

NUMERO NOM      C O O R D O N N E S      -GISEMENT-
PROFIL ELEM      -ABSCISSE-      -----X----- -----Y-----      --PROFIL--
-----
1 1      0.000      3393.012      29524.847      68.911
2 1      25.000      3415.090      29536.576      68.911
3 1      50.000      3437.167      29548.305      68.911
4 1      75.000      3459.245      29560.034      68.911
5 1      100.000      3481.323      29571.763      68.911
6 1      125.000      3503.401      29583.493      68.911
7 1      150.000      3525.478      29595.222      68.911
8 1      156.490      3531.210      29598.267      68.911
9 1      255.386      3618.546      29644.665      68.911
10 1      275.000      3635.867      29653.867      68.911
11 1      298.094      3656.261      29664.702      68.911
12 1      300.000      3657.944      29665.599      68.703
    
```

Report Style 3

```

REPO>984,G006,4=3
984G006                               3
                                     PROFIL EN LONG
                                     POINTS DE CONTACT

NOM      -----CARACTERISTIQUES-----      -LONGUEUR-      -----S----- -----Z-----
-----
1      PENTE =      -0.005      112.663
-----
2      S= 154.3370      Z= 126.0931      255.147
      R = 9000.090
-----
3      PENTE =      0.024      412.079
-----
3      R = -12000.480      58.865
-----
838.755   139.651
REPO>
    
```

Report Style 4

```

REPO>984,G006,4=4
984G006
4
ELEMENT  TYPE  PROFIL  -ABSCISSE--  ----COTE---  -----X-----  -----Y-----
1 1  PBT  1  0.0000  126.7113  3393.012  29524.847
1 1  PBT  2  25.0000  126.5955  3415.090  29536.576
1 1  PBT  3  50.0000  126.4798  3437.167  29548.305
1 1  PBT  4  75.0000  126.3640  3459.245  29560.034
1 1  PBT  5  100.0000  126.2482  3481.323  29571.763
2 2  PC  OE  112.6634  126.1896
2 2  PC  6  125.0000  126.1409  3503.401  29583.493
2 2  PC  7  150.0000  126.0942  3525.478  29595.222
2 2  PC  8  156.4903  126.1001  3531.210  29598.267
2 2  PC  9  255.3864  126.6663  3618.546  29644.665
2 2  PC  10  275.0000  126.9020  3635.867  29653.867
2 2  PC  11  298.0936  127.2412  3656.261  29664.702
2 2  PC  12  300.0000  127.2719  3657.944  29665.599
2 2  PC  13  325.0000  127.7112  3679.723  29677.869
2 2  PC  14  350.0000  128.2200  3700.958  29691.060
3 3  PT  OE  367.8107  128.6248
3 3  PT  15  375.0000  128.7954  3721.607  29705.149
3 3  PT  16  398.2003  129.3456  3740.214  29719.004
    
```

Minor option 985/986 Report section strings in a stylised format

Minor option 985 in conjunction with option 001 describes the points on each section to be reported. 986 defines the range of cross sections to be tabulated. Up to 50 points for each cross section may be described and a library of 985/001 options may be initialised and used for a series of 986 options.

Critical points on cross sections may be selected and tabulated in a form appropriate for use on site. For other types of section output see options 992, 994, 985/983 and the section options themselves: SECTION 173/174

Input

Minor option 985

- \* Field 1 String label cut to be described

Minor option 001

- \* Field 1 - 10 Descriptive text to be output.

Up to 50 pairs of 985 and 001 records may be defined together. If following a 986 option another 985 and 001 record is defined, the full set must be redefined. However a series of 986 options may follow one group of 985/001 records.

Minor option 986

- \* Field 1 Reference string on which sections are based (must be a master string)
- \* Field 3 Initial character of section strings to be reported
- Field 4 Chainage interval (optional)
- Field 5 & 6 SPRD for point on reference string generating first sections to be output
- Field 8 & 9 SPRD for point on reference string generating last section to be output

Example

```
REPORT, SIMPLE DESIGN SECTIONS, SIMPLE DESIGN ROAD
985, ILEF
001, LEFT INTERFACE
985, VLEF
001, LEFT VERGE
985, MAST
001, CENTRE LINE
985, VRG1
001, RIGHT VERGE
985, IRI1
001, RIGHT INTERFACE
986, MAST, , R, 20, 5=60, 8=200
986, MAST, , R, 10, 5=200, 8=300
999
```

This would produce the output shown.

Output

```
MASTER STRING 'MAST'                                CHAINAGE 60.00
-----
```

FEATURE	LABEL	--EASTING--	-NORTHING-	-OFFSET-	-LEVEL
LEFT INTERFACE	ILEF	501463.512	111204.330	-4.509	50.497
LEFT VERGE	VLEF	501463.322	111204.791	-4.010	50.746
CENTRE LINE	MAST	501461.795	111208.499	0.000	50.653
RIGHT VERGE	VRG1	501460.268	111212.207	4.010	50.678
RIGHT INTERFACE	IRI1	501459.354	111214.424	6.408	51.877

```
=====
```

```
MASTER STRING 'MAST'                                CHAINAGE 80.00
-----
```

FEATURE	LABEL	--EASTING--	-NORTHING-	-OFFSET-	-LEVEL
LEFT INTERFACE	ILEF	501444.929	111196.736	-4.608	51.986
LEFT VERGE	VLEF	501444.711	111197.292	-4.010	52.285
CENTRE LINE	MAST	501443.244	111204.757	4.010	52.173
RIGHT VERGE	VRG1	501441.778	111204.75	4.010	52.173
RIGHT INTERFACE	IRI1	501441.012	111206.706	6.104	53.220

```
=====
```

Minor option 985/983 Report section strings in (PISTE) format

Minor option 985 in conjunction with option 001 allows identifying characters to be given to the strings cut by the cross sections. The initial 983 defines the range of cross sections to be reported and the cross section set reference character. Any additional cross section sets required can be defined using additional 983's. A final 983 is required to process the option. All cuts on a crosssection are output, plus interpolated values on the sub-strata at the limits of the top surface and at the zero offset. Option 985 is not yet available in graphics mode.

Input

Minor option 985

- \* Field 1 String label cut to be identified

Minor option 001

Field 1 Two characters to identify cut string

Up to 50 pairs of 985 and 001 records may be defined together.

Minor option 983 (initial 983)

- \* Field 1 Reference string on which sections are based (must be a master string)
- \* Field 3 Initial character of section string to be reported
- Field 4 Chainage interval (optional)
- Field 5 & 6 SPRD for point on reference string generating first sections to be output
- Field 8 & 9 SPRD or point on reference string generating last section to be output.

Minor option 983 (intermediate 983)

Field 3 Initial character of further section strings to be reported

Minor option 983 (final 983)

Blank

Example

```
REPORT, SIMPLE DESIGN SECTIONS, SIMPLE DESIGN ROAD
985, ILEF
001, TG
985, VLEF
001, LG
985, CLEF
001, CG
985, MASTY
001, TC
985, CRIG
001, XD
985, VRI1
001, LD
985, VRI2
001, LD
985, IRI1
001, TD
985, IRI2
001, TD
983, MAST, , H, 5=280, 8=300
983, 3=H
983
```

PROFIL NO	31	S=	280.000	Z PROJET	67.114	9 POINTS
ABSC	-7.428	-4.010	-3.010	-3.000 C	0.000 T	3.000 X
COTE	65.580	67.289	67.289	67.189 G	67.114 C	67.039 D
ABSC	3.010	4.010	4.555			
COTE	67.139	67.139	66.867			

```

                A S S I S E      1
ABSC   -7.428   -4.010   -3.010   -3.000   0.000   3.000
COTE   65.580   67.289   67.289   67.189   67.114   67.039
ABSC   3.010   4.010   4.555
COTE   67.139   67.139   66.867

```

```

PROFIL NO    32  S=      290.000  Z PROJET      67.796      9 POINTS

```

```

ABSC   -7.317   -4.010 L  -3.010   -3.000 C  0.000 T  3.000 X
COTE   66.317   67.971 G  67.971   67.871 G  67.796 C  67.721 D
ABSC   3.010   4.010   4.622
COTE   67.821   67.821   67.515

```

```

                A S S I S E      1

```

```

ABSC   -7.317   -4.010   -3.010   -3.000   0.000   3.000
COTE   66.317   67.971   67.971   67.871   67.796   67.721
ABSC   3.010   4.010   4.622
COTE   67.821   67.821   67.515

```

```

W751 SECTION STRING H00X NOT FOUND
W751 SECTION STRING H00X NOT FOUND

```

```

PROFIL NO    34  S=      300.000  Z PROJET      68.465      9 POINTS

```

```

ABSC   -7.496   -4.010 L  -3.010   -3.000 C  0.000 T  3.000 X
COTE   66.896   68.639 G  68.639   68.539 G  68.465 C  68.390 D
ABSC   3.010   4.010   4.711
COTE   68.490   68.489   68.139

```

```

                A S S I S E      1

```

```

ABSC   -7.496   -4.010   -3.010   -3.000   0.000   3.000
COTE   66.896   68.639   68.639   68.539   68.465   68.390
ABSC   3.010   4.010   4.711
COTE   68.490   68.489   68.139

```

```
001TD
```

```
983MAST  R      20      280      300
```

```
983
```

```
983
```

```
1
```

```
DATE : 1/11/89 TIME : 16/44/12
```

```
PAGE : 2
```

```
MOSS
```

```

PROFIL NO    31  S=      280.000  Z PROJET      67.108      9 POINTS

```

```

ABSC   -7.414 T  -4.010   -3.010   -3.000 C  0.000 T  3.000 C
COTE   65.581 G  67.283   67.283   67.183 G  67.108 C  67.033 D
ABSC   3.010   4.010   4.544
COTE   67.133   67.133   66.866

```

```

                A S S I S E      1

```

```

ABSC   -7.414   0.000   0.959   4.544
COTE   65.581   66.431   66.541   66.866

```

```
1
```

```
DATE : 1/11/89 TIME : 16/44/12
```

```
PAGE : 3
```

```
MOSS
```

```

PROFIL NO    34  S=      300.000  Z PROJET      68.465      9 POINTS

```

```

ABSC   -7.506 T  -4.010 L  -3.010   -3.000 C  0.000 T  3.000 C
COTE   66.892 G  68.640 G  68.640   68.540 G  68.465 C  68.390 D
ABSC   3.010   4.010   4.712
COTE   68.490   68.490   68.139

```

```

                A S S I S E      1

```

```

ABSC   -7.506   -2.952   0.000   4.712
COTE   66.892   67.358   67.659   68.139
999

```

```
END OF REPORT-----
```

```
FINISH
```

```
FINI
```

## Minor option 987 Check record pointers

Checks the pointer organisation within the model file.

This option should be used if you suspect that the model file has been corrupted; for example, if a MODELFILE FULL message appears, or if a



MOSS job runs out of time, or if unexpected data is found in a model. It should also be used before and after every compress model file.

The option checks the following pointers for validity :

- pointers from the names index to string indexes
- pointers between blocks of the name index
- pointers from string indexes to data records
- pointers between blocks of the string indexes for each model.

The option prints out each names index entry as it is encountered, and can optionally also print out each string index entry. A corrupt pointer is flagged by a message, which may indicate a corrupt string or model to be deleted.

### Input

### Graphics

REP002, REP014

REPORT minor options	Check record pointers
Distance and bearing	String index entries (T)
Distance & brg (normal)	
Intersection of 2 strings	
Normal intersections	
Triangle	
Check record pointers	
Check for loops in string	
Picto format information	
Model file records used	
End REPORT	

### Linemode

#### Minor option 987

Field 1 LABS if string index entries are to be printed. Otherwise leave blank.

### Minor option 988 Check for loops in string

This option checks for loops in a closed boundary string.

A loop is created when a boundary string crosses itself, forming a subsidiary polygon. This option detects such a condition.

- ◇ *Minor option 032 will remove such loops from strings other than closed boundary strings, without first confirming their presence.*

Input

Graphics

REP002, REP015

REPORT minor options	Check for loops in string
Distance and bearing	String label
Distance & brg (normal)	
Intersection of 2 strings	
Normal intersections	
Triangles	
Check record pointers	
Check for loops in string	
Piste format information	
Model file records used	
End REPORT	

Linemode

Minor option 988

- \* Field 1 Label of string to be tested

Output

For each crossover within the string, the option prints the X and Y coordinates of the crossover and the point numbers of the string links which form the crossover. In the normal case with just one loop, no such crossover points will be printed.

```

988CLOS
NUMBER OF LOOPS WITHIN STRING CLOS
THERE ARE NO INTERSECTIONS
STRING CLOS CONTAINS 1 LOOP
988CLOS
NUMBER OF LOOPS WITHIN STRING CLOS
LINK BETWEEN POINTS INTERSECTS LINK BETWEEN POINTS AT INTERSECTION POINT-----X-----Y-----
                2-3                    5-6                    200.000  150.000
STRING CLOS CONTAINS 2 LOOPS

```

Minor option 989 Model file records used

Determines the number of records used in the model file and, of those, the number that contain current information.

These two numbers will differ, because when models are deleted the space they occupied cannot be reused until a COMPRESS option is run. This

option can be used to give a guide to when the COMPRESS option should be run.

## Input

### Graphics

#### REP002

<b>REPORT minor options</b>
Distance and bearing
Distance & brg (normal)
Intersection of 2 strings
Normal intersections
Triangles
Check record pointers
Check for loops in string
Piste format information
Model file records used
End REPORT

## Linemode

### Minor option 989

Leave all fields blank.

## Output

```
REPO>989
989

NUMBER OF RECORDS ACTUALLY OCCUPIED IS 1425 OUT OF 2247 USED
NUMBER OF RECORDS AVAILABLE IS 3000
COMPRESS WILL LEAVE 1575 WHICH IS
EQUIVALENT TO 126000 3-D POINTS
```

## Minor option 990 Models

Lists the models in your database.

## Input

### Graphics

REP002, REP004

REPORT minor options	Models
Add comments to input log	Partial names (1-4)
Define system parameters	Partial names (5-8)
Define linear units	Sort A-Z or by date (T)
Define string masking	
Models	
Strings	
String details	
Geometry string details	
Section strings	
Distance and bearing	

**Partial names:** Optionally, you may select the models on partial name. Give up to four characters for the first entry and another four characters for the second entry.

**Sort A-Z:** The models may be sorted either alphabetically or by the date that the model was last updated.

### Linemode

#### Minor option 990

Field 1,2 Up to eight characters to report all names beginning with the typed letters

Field 3 SORT to sort the models alphabetically  
DATE to sort the models on date last updated.

## Minor option 991 Strings

Reports string index information for one or all of the strings in a given model.

String index information consists of the label, the subreference or contour level, the string element contents indicator, the maximum and minimum values of the first two dimensions of string, the record address of the start of the string on the model file, and the word position of the start of the string within the record.

The minimum values of the first two dimensions are rounded down to a whole unit, and the maximum rounded up.

The selection mask facility may be used to select groups of strings or exclude strings for printing. Some users are only interested in the min-max bounding box of a string or set of strings, and a feature exists to suppress the individual string details.

## Input

### Graphics

REP002, REP005

REPORT minor options	Strings
Add comments to input log	String label
Define system parameters	SORT / SUMM (T)
Define linear units	
Define string masking	
Models	
Strings	
String details	
Geometry string details	
Section strings	
Distance and bearing	

**String label:** Give the label of one string to be printed. If omitted the string index information is printed for all strings or all strings satisfying a current selection mask table. Alternatively you can give a partial label mask.

**SORT:** Toggle to SORT to report the string labels in ascending order.

**SUMM:** Toggle to SUMM to report the terminating summary only.

### Linemode

#### Minor option 991

- Field 1      Type the label of the one string to be printed.  
If omitted the string index information is printed for all strings or all strings satisfying a current selection mask table. Alternatively an inclusive selection may be typed.
- Field 3      Type SORT to report the string labels in ascending order.  
Type SUMM to report the 991 terminating summary only.

Output

991

LABEL	SUBREF	CONTENTS	NO.PTS	X -MIN	Y -MIN	X -MAX	Y -MAX	RECORD	LOC.
1111		7703	5	0	1	5	6	906	1
2222		7703	2	0	1	2	2	906	31
3333		7703	2	0	0	2	2	906	43
4444		7703	4	0	0	3	4	907	1
5555		7703	4	0	2	3	6	907	25
SUMMARY FOR	5	STRINGS -	NO.PTS	X -MIN	Y -MIN	X -MAX	Y -MAX	NO.WORDS	
			17	0	0	5	6	102	

Minor option 992 String details

Reports the contents of one or all of the strings stored in a given model. When just a single string is to be reported, you can report on either the whole string or just part of it. Details reported include plan distance, slope length and slope between successive points, and also the accumulative total distance between points.

The selection mask facility may be used to select groups of strings for reporting. This option will report all the commonly used string types in appropriate formats.

Input

Graphics

REP002, REP006

REPORT minor options	String details
Add comments to input log	String label
Define system parameters	Report style (T)
Define linear units	Sort (T)
Define string masking	Start chainage / X coord
Models	Start point no. / Y coord
Strings	End chainage / X coord
String details	End point no. / Y coord
Geometry string details	
Section strings	
Distance and bearing	

**String label:** If only one string is required give the label.

If omitted, the string index information is printed for all strings or all strings satisfying a current selection mask table.

Alternatively, you can give a partial label mask.

**Report style:** Toggle the report style to obtain the following reports:

- FULL Plan distance, slope distance and accumulative distance.
- SLOP Slope length
- ZERO All strings containing zero levels
- NULL All strings containing null levels
- FNDI Plan distance, slope distance and accumulative distance without the lengths across discontinuities
- SNDI Slope length without the lengths across discontinuities

**Sort:** Toggle to SORT to report the strings in ascending label order.

◇ *Discontinuous bearings and string discontinuities will be reported automatically.*

Linemode

Minor option 992

- Field 1 Type the label if only one string is required.  
If omitted all the strings or all the strings in the model satisfying a current selection mask table will be output. Alternatively a partial label mask may be used.
- Field 2 Type FULL if the plan distance, percentage slope and running cumulative plan distance are to be calculated and printed.  
  
Type SLOP to report slope lengths.  
  
Type ZERO to report only strings with zero levels.  
  
Type NULL to report only strings with null levels.  
  
Type FNDI to report the plan distance, percentage slope and cumulative plan distance without the lengths across discontinuities included in the total distance.  
  
Type SNDI to report slope lengths without the lengths across discontinuities included in the total length.
- Field 3 Type SORT to report the strings in ascending label order.
- Field 5 & 6 SPRD for the first point in the string to be printed.
- Field 8 & 9 SPRD for the last point in the string to be printed.
- ◇ *If fields 5, 6, 8, and 9 are typed field 1 must be typed.*
- ◇ *For full details of SLOP see Chapter 6, page 6 - 189*

Output

Example 1

Report of a single string:

```

REPO>992, RCH1, 6=25, 9=32
992RCH1                                25                                32
LABEL  SUBREF  CONTENTS NO.PTS  X -MIN  Y -MIN  X -MAX  Y -MAX RECORD LOC.

```

RCH1	7703	298	1209	1097	1896	1623	19	367
POINT	-----X-----	-----Y-----	-----Z-----					
25	1238.806	1213.992	130.800					
26	1240.018	1218.842	131.250					
27	1241.231	1223.693	131.700					
28	1242.444	1228.544	132.150					
29	1243.656	1233.395	132.600					
30	1244.869	1238.245	133.050					
31	1246.082	1243.096	133.500					
32	1247.294	1247.947	133.950					

Example 2

FULL report of a single string:

```
REPO>992,RCH1,6=25,9=32,2=FULL
992RCH1FULL
```

LABEL	SUBREF	CONTENTS	NO.PTS	X -MIN	Y -MIN	X -MAX	Y -MAX	RECORD	LOC.	
RCH1		7703	298	1209	1097	1896	1623	19	367	
POINT	-----X-----	-----Y-----	-----Z-----					---SLOPE%	---LENGTH--	---ACCUM L---
										0.000
										120.000
25	1238.806	1213.992	130.800					9.000	5.000	120.000
26	1240.018	1218.842	131.250							125.000
27	1241.231	1223.693	131.700					9.000	5.000	130.000
28	1242.444	1228.544	132.150					9.000	5.000	135.000
29	1243.656	1233.395	132.600					9.000	5.000	140.000
30	1244.869	1238.245	133.050					9.000	5.000	145.000
31	1246.082	1243.096	133.500					9.000	5.000	150.000
32	1247.294	1247.947	133.950					9.000	5.000	155.000

Example 3

Report slope length of a single string:



LABEL	SUBREF	CONTENTS	NO.PTS	X -MIN	Y -MIN	X -MAX	Y -MAX	RECORD	LOC.	SLOPE	ACCUM
MAST	GAST	7706	149	133158	452601	133853	452800	2580	337		
POINT											
		---X---	---Y---	---Z---	---C---	---B---	---R---	--SLOPE%	--LENGTH--	--SLOPE L--	
1	133158.638	452601.683	4.487	.000	47 37 15.1	INFINITY					.000
2	133166.025	452608.424	5.060	10.000	47 37 15.1	INFINITY		5.728	10.016		10.016
3	133173.412	452615.164	5.633	20.000	47 37 15.1	INFINITY		5.728	10.016		20.033
4	133180.799	452621.904	6.206	30.000	47 37 15.1	INFINITY		5.728	10.016		30.049
5	133188.186	452628.645	6.778	40.000	47 37 15.1	INFINITY		5.728	10.016		40.066
6	133195.573	452635.385	7.351	50.000	47 37 15.1	INFINITY		5.728	10.016		50.082
7	133202.960	452642.125	7.924	60.000	47 37 15.1	INFINITY		5.728	10.016		60.098
8	133210.347	452648.866	8.497	70.000	47 37 15.1	INFINITY		5.728	10.016		70.115
9	133217.734	452655.606	9.069	80.000	47 37 15.1	INFINITY		5.728	10.016		80.131
10	133225.121	452662.346	9.642	90.000	47 37 15.1	INFINITY		5.728	10.016		90.148
11	133232.508	452669.087	10.215	100.000	47 37 15.1	INFINITY		5.728	10.016		100.164
12	133239.895	452675.827	10.788	110.000	47 37 15.1	INFINITY		5.728	10.016		110.180

### Example 4

### Cadastre string output

LABEL	SUBREF	CONTENTS	NO.PTS	X -MIN	Y -MIN	X -MAX	Y -MAX	RECORD	LOC.	
P001	SHEE	7710	7	99999	119999	180000	200000	92	61	
POINT										
		---X---	---Y---	---Z---		-REFERENCE-- -BEARING---	-SURVEY- -NUMBER-	FEATURE CODE	CADASTRAL NUMBER	POINT NUMBER
1	100000.000	120000.000	100.000	135	0	0.0	12345678	COD1	CADASTRAL	TEXT
2	120000.000	140000.000	220.000	180	0	0.0	87654321	COD2	MORE CADaST	TEXT
3	145000.000	150000.000	230.000	198	0	0.0	87114321	COD3	MORE CAD1ST	TEXT
4	160000.000	160000.000	240.000	225	0	0.0	87652221	COD4	MORE CAD2ST	TEXT
5	170000.000	165000.000	250.000	207	0	0.0	87653321	COD5	MORE CAD3ST	TEXT
6	175000.000	180000.000	260.000	189	0	0.0	87444321	COD6	MORE CAD4ST	TEXT
7	180000.000	200000.000	200.000	207	0	0.0	87655521	COD7	MORE CAD5ST	TEXT
LABEL SUBREF CONTENTS NO.PTS X -MIN Y -MIN X -MAX Y -MAX RECORD LOC.										
P002	NORT	7710	7	99999	109999	180000	200000	92	173	
POINT										
		---X---	---Y---	---Z---		-REFERENCE-- -BEARING---	-SURVEY- -NUMBER-	FEATURE CODE	CADASTRAL NUMBER	POINT NUMBER
1	100000.000	120000.000	100.000	135	0	0.0	12345678	COD1	CADASTRAL	TEXT
2	120000.000	140000.000	220.000	180	0	0.0	87654321	COD2	MORE CADaST	TEXT
3	145000.000	170000.000	230.000	198	0	0.0	87114321	COD3	MORE CAD1ST	TEXT
4	160000.000	200000.000	240.000	225	0	0.0	87652221	COD4	MORE CAD2ST	TEXT
5	170000.000	165000.000	250.000	207	0	0.0	87653321	COD5	MORE CAD3ST	TEXT
6	175000.000	150000.000	260.000	189	0	0.0	87444321	COD6	MORE CAD4ST	TEXT
7	180000.000	110000.000	200.000	207	0	0.0	87655521	COD7	MORE CAD5ST	TEXT
999										
END OF REPORT-----										

## Minor option 993 String details - user defined format

Reports selected data items from one or more strings in user defined format.

In certain cases the output formats used by minor option 992 may not be satisfactory. In such cases 993 allows you to define the items within a string to be selected for reporting, and defines the report format to be used and the report heading and page headings required.

There are facilities to report the point sequence numbers as the first output field.

Minor options 001 and 003 are used to provide supplementary information to the 993 option. The selection mask facility may be used to select groups of strings for reporting.

◇ *Not available in graphics.*

## Input

### Linemode

#### Minor option 993

Field 1 Type the label of the string if only one string is required. If omitted, all the strings or all the strings in the model satisfying a current selection mask table will be output. Alternatively a partial label mask may be typed.

Field 2 If NUMB is typed the point sequence numbers in the string are printed as the first output field. An integer output field must be provided in the 001 FORMAT record. It is possible to arrange the sequence number to appear on the output at any position in the printed line by skilful use of the FORMAT statement.

Field 3 Type NEWP if a skip to a new page is required for each string to be output.

Field 5 & 6 SPRD for the first point in the string to be printed.

Field 8 & 9 SPRD for the last point in the string to be printed.

◇ *If fields 5, and 6 or 8 and 9 are typed, field 1 must be typed.*

◇ *For information about string types, refer to Chapter 2.*

#### Order of items

The order of items to be printed is specified using minor option 003

#### Minor option 003

Field 1 Type ORDR

- \* Field 5 -10 Contain the items within each string element in the order in which they are to be output.

#### Report headings

The heading to be printed at the beginning of the report is defined using option

001. Up to two lines may be printed each consisting of up to 117 characters. Two records may be used to define each line. The records must appear in the order given below: that is, report headings followed by page headings.

Minor option 001

- \* Field 1 HEAD
- \* Field 2 LINE
- Field 3 Line number 1 or 2 (left justified) or blank for continuation records
- Field 4-10 Characters for heading.

Two HEAD options may be used for each heading line. If the heading line number is omitted, either 1 or the previous line number is assumed. The text will be printed in columns 1-64 and 65-117 from successive HEAD options. Any excess characters will be ignored.

Page headings

Up to two lines of 117 character headings may be output at the top of each page of printed output.

Output

```

993LAB1
003ORDR          3          1          2
001HEADLINE1                                TESTS WITH REPO
001HEADLINE1  RT TEST MODEL
001HEADLINE2  -----
001HEADLINE2                                993 LISTING OF
001PAGELINE1  STRING LAB1
001PAGELINE2  -----
001PAGELINE2                                -----
001FORMAT(' Z=',F10.3,', X=',F10.3,', Y=',F10.3)
999
1
DATE : 20OCT89  TIME : 11:42:22                PAGE : 36
993 TESTS OF REPORT TEST ONE

                                TESTS WITH REPORT TEST MODEL
                                -----
                                993 LISTING OF STRING LAB1
                                -----

Z= 100.000, X= 100.000, Y= 200.000
Z= 100.000, X= 200.000, Y= 300.000
Z= 100.000, X= 320.000, Y= 320.000
Z= 100.000, X= 420.000, Y= 300.000
Z= 100.000, X= 620.000, Y= 500.000

END OF 993 OPTION-----

```

Minor option 994 Section strings

Reports section strings between SPRD range on the reference string. You can use the selection mask facility here to select or reject groups of strings. You can also specify the start and end points on the reference string for the cross sections to be reported.

Input

Graphics

REP002, REP007

REPORT minor options	Section strings
Add comments to input log	Section set ref letter
Define system parameters	Reference string label
Define linear units	Start chainage / X coord
Define string masking	
Models	Start point no. / Y coord
Strings	End chainage / X coord
String details	End point no. / Y coord
Geometry string details	
Section strings	
Distance and bearing	

Linemode

Minor option 994

- \* Field 1 Initial character of section set to be reported
- \* Field 2 Reference string
- Field 5 & 6 SPRD for start point on reference string
- Field 8 & 9 SPRD for end point on reference string
- ◇ *You must give a reference string.*

Example

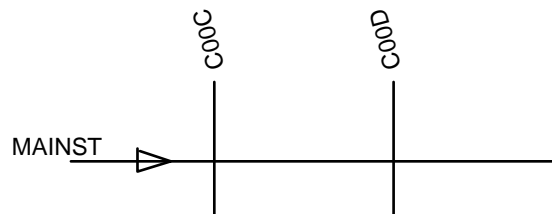


Figure 4 - 40 Reporting sections

994, CR, MAINST, 5=100, 8=11050

Output

```

REPORT ROAD DESIGN SECTIONS          ROAD DESIGN          W147 CURVE FITTING INVOKED
----- M O D E L   N A M E -----
ROAD DESIGN SECTIONS          RECORD SECURITY DATE LAST USED -----
                                4644   FREE    25SEP95 16:15:50
    
```



```
ROAD DESIGN          4602  FREE          23OCT95 10:38:10
994C  MAIN          100          110
```

```
LABEL  SUBREF  CONTENTS NO.PTS  X -MIN  Y -MIN  X -MAX  Y -MAX  RECORD LOC.
C00C   MAIN    7705     9    4069    8285    4085    8295    4719  311
```

```
CHAINAGE    100.000
-----
```

```
POINT  ----X----  ----Y----  ---Z----  ---OFFSET--  -LABEL CUT-
1      4069.523  8294.349  28.734    -8.407    ILFM
2      4070.620  8293.739  29.571    -7.152    VLMN
3      4073.679  8292.038  29.746    -3.652    KLMN
4      4073.680  8292.037  29.621    -3.650    CLMN
5      4076.870  8290.263  29.535    0.000    MAIN
6      4080.060  8288.489  29.415    3.650    CRMN
7      4080.062  8288.488  29.540    3.652    KRMS
8      4083.120  8286.786  29.365    7.152    VRMS
9      4084.663  8285.929  28.188    8.917    IRF1
```

```
LABEL  SUBREF  CONTENTS NO.PTS  X -MIN  Y -MIN  X -MAX  Y -MAX  RECORD LOC.
C00D   MAIN    7705     9    4075    8294    4089    8303    4719  401
```

```
CHAINAGE    110.000
-----
```

```
POINT  ----X----  ----Y----  ---Z----  ---OFFSET--  -LABEL CUT-
1      4075.073  8302.814  29.120    -7.732    ILFM
2      4075.576  8302.526  29.507    -7.152    VLMN
3      4078.614  8300.787  29.682    -3.652    KLMN
4      4078.615  8300.786  29.557    -3.650    CLMN
5      4081.783  8298.973  29.435    0.000    MAIN
6      4084.951  8297.159  29.309    3.650    CRMN
7      4084.952  8297.158  29.434    3.652    KRMS
8      4087.990  8295.419  29.259    7.152    VRMS
9      4088.820  8294.944  28.621    8.109    IRF1
```

999

END OF REPORT-----

OUTPut

```
REPORT  SIMPLE DESIGN SECTIONS          SIMPLE DESIGN ROAD
                                             W147 CURVE FITTING INVOKED
```

```
----- M O D E L  N A M E -----  RECORD  SECURITY  DATE LAST USED -----
SIMPLE DESIGN SECTIONS             210    FREE      9OCT89
SIMPLE DESIGN ROAD                 206    FREE      9OCT89
994R  MAST                          10                                 11
```

```
LABEL  SUBREF  CONTENTS NO.PTS  X -MIN  Y -MIN  X -MAX  Y -MAX  RECORD LOC.
R00A   MAST    7705     9    501441  111196  501445  111207  269  1
```

```
CHAINAGE    80.000
-----
```

```
POINT  ----X----  ----Y----  ---Z----  ---OFFSET--  -LABEL CUT-
1      501444.929  111196.736  51.986    -4.608    ILEF
2      501444.711  111197.292  52.285    -4.010    VLEF
3      501444.345  111198.223  52.285    -3.010    KLEF
4      501444.341  111198.232  52.185    -3.000    CLEF
5      501443.244  111201.024  52.148    0.000    MAST
6      501442.147  111203.817  52.073    3.000    CRIG
7      501442.143  111203.826  52.173    3.010    KRI1
8      501441.778  111204.757  52.173    4.010    VRG1
9      501441.012  111206.706  53.220    6.104    IRI1
```

```
LABEL  SUBREF  CONTENTS NO.PTS  X -MIN  Y -MIN  X -MAX  Y -MAX  RECORD LOC.
R00B   MAST    7705     9    501431  111192  501436  111203  269  91
```

```
CHAINAGE    90.000
-----
```

```
POINT  ----X----  ----Y----  ---Z----  ---OFFSET--  -LABEL CUT-
1      501435.627  111192.932  52.664    -4.797    ILEF
2      501435.347  111193.667  53.058    -4.010    VLEF
3      501434.991  111194.601  53.058    -3.010    KLEF
4      501434.987  111194.611  52.958    -3.000    CLEF
5      501433.919  111197.414  52.903    0.000    MAST
6      501432.850  111200.217  52.828    3.000    CRIG
7      501432.847  111200.227  52.928    3.010    KRI1
8      501432.491  111201.161  52.928    4.010    VRG1
9      501431.830  111202.894  53.855    5.864    IRI1
```

999

END OF REPORT-----

## Minor option 995 Distance and bearing (of line)

Determines the distance and bearing, either from a given point to the nearest actual point on the string, or to all the points on a string within a given radius.

### Input

#### Graphics

REP002, REP008

REPORT minor options	Distance & bearing
Add comments to input log	String label
Define system parameters	Radius
Define linear units	Centre X of search circle
Define string masking	Centre Y of search circle
Models	Centre Z of search circle
Strings	
String details	
Geometry string details	
Section strings	
Distance and bearing	

### Linemode

#### Minor option 995

- \* Field 1 String label.
- Field 4 Radius within which all points on the string are selected. If omitted only the nearest point is taken.
- \* Field 5 & 6 Coordinates of point from which radius is drawn.
- Field 7 Z coordinate of the point. If this field is typed then the three dimensional distance will be reported.

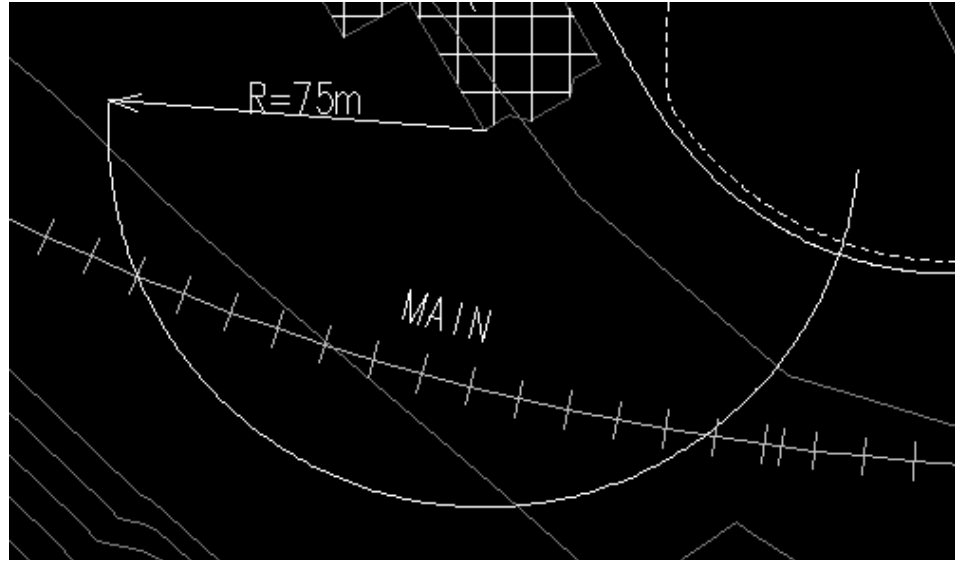


Figure 4 - 41 Reporting distance and bearing

Output

```

REPORT ROAD DESIGN
                                                    W147 CURVE FITTING INVOKED

----- M O D E L   N A M E -----   RECORD   SECURITY   DATE LAST USED -----
ROAD DESIGN                               4602     FREE       23OCT95 10:38:10

995MAIN                                75  4529.240  8739.395

POINTS ON STRING MAIN WITHIN RADIUS      75.000 OF POINT      4529.240  8739.395

LABEL POINT    -PLAN DIST-- --BEARING--   -----X-----   -----Y-----   ---Z---   -----C-----   -----B-----   -----R-----
MAIN  75        74.812  187 19 10.7   4519.70866   8665.19303   36.683   690.000  52 19 37.6   -510.000
MAIN  76        68.034  181 24 43.7   4527.56337   8671.38176   36.879   700.000  51 12 13.2   -510.000
MAIN  77        61.968  174 23 32.6   4535.29523   8677.72330   37.057   710.000  50  4 48.8   -510.000
MAIN  78        56.846  166  5 40.1   4542.90126   8684.21522   37.216   720.000  48 57 24.4   -510.000
MAIN  79        52.943  156 28  2.9   4550.37855   8690.85502   37.358   730.000  47 50  0.0   -510.000
MAIN  80        50.545  145 41 56.7   4557.72422   8697.64015   37.481   740.000  46 42 35.6   -510.000
MAIN  81        49.871  134 17 40.1   4564.93544   8704.56800   37.586   750.000  45 35 11.2   -510.000
MAIN  82        50.988  122 59  6.7   4572.00944   8711.63591   37.672   760.000  44 27 46.8   -510.000
MAIN  83        53.786  112 27 59.5   4578.94351   8718.84115   37.741   770.000  43 20 22.4   -510.000
MAIN  84        58.020  103  9 52.9   4585.73497   8726.18096   37.791   780.000  42 12 57.9   -510.000
MAIN  85        63.402  95 11 47.6   4592.38122   8733.65252   37.823   790.000  41  5 33.5   -510.000
MAIN  86        69.664  88 28 18.3   4598.87970   8741.25295   37.837   800.000  39 58  9.1   -510.000
    
```

999

END OF REPORT-----

OUTPut

```

REPORT MODEL106
                                                    W146 NO CURVE FITTING

----- M O D E L   N A M E -----   RECORD   SECURITY   DATE LAST USED -----
MODEL106                               908     FREE       18JUL88

RADIUS SPECIFIED IS THAT OF CIRCULAR LOOP & GIVEN POINT IS CENTRE OF LOOP
995RHL1                                100.0   500.0   500.0

POINTS ON STRING RHL1 WITHIN RADIUS      100.000 OF POINT      500.000  500.000

LABEL POINT    -PLAN DIST-- --BEARING--   -----X-----   -----Y-----   ---Z---
RHL1  1        100.000  0  0  0.0   500.00000   600.00000   10.000
RHL1  2        100.000  4  0  0.8   506.97600   599.75600   10.000
RHL1  3        100.000  7 59 59.3   513.91700   599.02700   10.000
RHL1  4        100.000 11 59 59.6   520.79100   597.81500   10.000
RHL1  5        100.000 16  0  0.6   527.56400   596.12600   10.000
RHL1  6        100.000 20  0  0.2   534.20200   593.96900   10.000
RHL1  7        100.001 24  0  0.3   540.67400   591.35500   10.000
RHL1  8        100.000 27 59 59.5   546.94700   588.29500   10.000
RHL1  9        100.000 31 59 59.9   552.99200   584.80500   10.000
RHL1 10        100.000 35 59 58.8   558.77800   580.90200   10.000
RHL1 11        100.001 39 59 59.6   564.27900   576.60500   10.000
RHL1 12        100.000 44  0  0.2   569.46600   571.93400   10.000
RHL1 13        100.000 47 59 59.4   574.31400   566.91300   10.000
RHL1 14        100.000 52  0  0.1   578.80100   561.56600   10.000
    
```

RHL1	15	100.000	56	0	0.8	582.90400	555.91900	10.000
RHL1	16	100.000	59	59	59.4	586.60200	550.00000	10.000
RHL1	17	100.000	63	59	59.8	589.87900	543.83700	10.000
RHL1	18	100.000	67	59	59.1	592.71800	537.46100	10.000
RHL1	19	100.000	71	59	59.6	595.10600	530.90200	10.000
RHL1	20	100.000	76	0	0.6	597.03000	524.19200	10.000
RHL1	21	100.000	79	59	59.7	598.48100	517.36500	10.000
RHL1	22	100.000	83	59	59.6	599.45200	510.45300	10.000
RHL1	23	100.000	87	59	59.9	599.93900	503.49000	10.000
RHL1	24	100.000	92	0	0.1	599.93900	496.51000	10.000
RHL1	25	100.000	96	0	0.4	599.45200	489.54700	10.000
RHL1	26	100.000	100	0	0.3	598.48100	482.63500	10.000
RHL1	27	100.000	103	59	59.4	597.03000	475.80800	10.000
RHL1	28	100.000	108	0	0.4	595.10600	469.09800	10.000
RHL1	29	100.000	112	0	0.9	592.71800	462.53900	10.000
RHL1	30	100.000	116	0	0.2	589.87900	456.16300	10.000
RHL1	31	100.000	119	59	59.5	586.60300	450.00000	10.000
RHL1	32	100.000	123	59	59.2	582.90400	444.08100	10.000
RHL1	33	100.000	127	59	59.9	578.80100	438.43400	10.000
RHL1	34	100.000	131	59	59.2	574.31500	433.08700	10.000
RHL1	35	100.000	135	59	59.8	569.46600	428.06600	10.000
RHL1	36	100.000	139	59	59.0	564.27900	423.39600	10.000
RHL1	37	100.001	143	59	59.6	558.77900	419.09800	10.000
RHL1	38	100.000	148	0	0.1	552.99200	415.19500	10.000
RHL1	39	100.000	152	0	0.5	546.94700	411.70500	10.000

## Minor option 996 Normals to a string Distance and bearing (of normal)

Given a point, this option determines all the normals to a string passing through that point. It calculates the distance and bearing from the given point to the point of intersection of the normal with the string, and also the coordinates of the point of intersection.

This option determines all the normals to a string which pass through a point or a string of points. It calculates the distance and bearing from the point(s) to the point of intersection of the normal with the string, and also the coordinates of the point of intersection.

Curve fitting is invoked automatically to allow accurate calculation of the point of intersection on curved strings. Option 017 may be used to switch off curve fitting if required.

In Graphics mode, the option is split into two functions; *Single normal onto string* and *Multiple normals onto string*.



Input

Graphics

REP002, REP011, REP009

REPORT minor options	Report normal intersection	Single normal onto string
Distance and bearing	Single normal onto string	String label
Intersection of 2 strings	Multiple normals onto str	Plan or slope (T)
Normal intersections	Normal(s) from a string	Report style (T)
Triangles	String differences	X coordinate
Check record pointers	End REPORT	Y coordinate
Check for loops in string		Z coordinate
Piste format information		
Model file records used		
End REPORT		

REP002, REP011, REP022

REPORT minor options	Distance & brg (normal)
Distance and bearing	String label
Distance & brg (normal)	X coordinate
Intersection of 2 strings	Y coordinate
Normal intersections	Z coordinate
Triangles	
Check record pointers	
Check for loops in string	
Piste format information	
Model file records used	
End REPORT	

REPORT minor options	Report normal intersection	Multiple normals onto str
Distance and bearing	Single normal onto string	String label
Intersection of 2 strings	Multiple normals onto str	Ref points string label
Normal intersections	Normal(s) from a string	Plan or slope (T)
Triangles	String differences	Report style (T)
Check record pointers	End REPORT	Start chainage / X coord
Check for loops in string		Start point no. / Y coord
Piste format information		End chainage / X coord
Model file records used		End point no. / Y coord
End REPORT		

Linemode

**Single normal onto string**

Minor option 996

- \* Field 1      Label of string onto which normal is dropped.
- Field 2      PLAN - report distances as plan distances  
                 SLOP - report distances as slope distances
- Field 4      Report style  
                 1 - Abbreviated output (default)  
                 2 - Detailed output  
                 3 - Tabular output
- \* Field 1      String label.
- \* Field 5 & 6    Coordinates of point through which the normals will pass.
- Field 7      Z coordinate of point through which the normals will pass.
- ◇ *If you specify a Z coordinate in Field 7, the slope distance will be reported provided Field 2 is blank or set to SLOP; otherwise the plan distance will be reported.*
- ◇ *If the z coordinate is typed in field 7 the spatial distance will be calculated; if omitted the plan distance will be calculated.*

**Multiple normals onto string**

Minor option 996

- \* Field 1      Label of string onto which normals are dropped.
- Field 2      PLAN - report distances as plan distances (default)  
                 SLOP - report distances as slope distances
- \* Field 3      Label of string containing reference points.
- Field 4      Report style  
                 1 - Abbreviated output (default)

- 2 - Detailed output
- 3 - Tabular output

See the output examples for details of the report styles.

Field 5 & 6 SPRD of start point of string containing reference points.

Field 8 & 9 SPRD of end point of string containing reference points.

◇ *If the string of reference points contains a null level, a plan distance will be calculated.*

## Output

### Example 1

#### Single normal onto string

```

PERPENDICULARS TO STRING RHL1 FROM POINT      520.791      597.815

LABEL POINT      -PLAN DIST-- --BEARING--  -----X-----  -----Y-----  ---Z---
RHL1    4 (EXACT)      0.000    0 0 0.0      520.79100      597.81500      10.000
RHL1    48 (EXACT)     199.879   189 59 57.9     486.08445      400.97274      10.000
RHL1    50 (EXACT)     199.878   194 0 8.6       472.42795      403.87601      10.000
    
```

### Example 2

#### Multiple normals onto string

##### Report style 1 - abbreviated output

```

MOSS
REPO, ROAD CURVE
996, KRIG, SLOP, AAST, 1
999
    
```

```

NORMALS DROPPED FROM POINTS ON STRING LABEL AAST ONTO STRING KRIG

PERPENDICULARS TO STRING KRIG FROM POINT      500761.567      111121.321      52.666

LABEL POINT      SLOPE DIST ---BEARING---  -----X-----  -----Y-----  ---Z---
KRIG    9-10      62.149   156 26 39.6     500786.39862     111064.36356     51.371

PERPENDICULARS TO STRING KRIG FROM POINT      500793.002      111130.111      51.916

LABEL POINT      SLOPE DIST ---BEARING---  -----X-----  -----Y-----  ---Z---
KRIG    8-9      58.648   160 14 23.1     500812.82587     111074.92803     50.719
    
```

##### Report style 2 - detailed output

```

MOSS
REPO, ROAD CURVE
996, KRIG, SLOP, AAST, 2
999
    
```

```

NORMALS DROPPED FROM POINTS ON STRING LABEL AAST ONTO STRING KRIG

LABEL POINT      -----X-----  -----Y-----  ---Z---
AAST    1 (EXACT)     500761.56700     111121.32100     52.666
KRIG    9-10         500786.39862     111064.36356     51.371
PLAN DISTANCE =      62.135
SLOPE DISTANCE =      62.149
CROSSFALL      = -0.0208492
LEVEL DIFF.    =      -1.295

NORMALS DROPPED FROM POINTS ON STRING LABEL AAST ONTO STRING KRIG

LABEL POINT      -----X-----  -----Y-----  ---Z---
AAST    2 (EXACT)     500793.00200     111130.11100     51.916
KRIG    8-9         500812.82587     111074.92803     50.719
PLAN DISTANCE =      58.636
SLOPE DISTANCE =      58.648
CROSSFALL      = -0.0204175
LEVEL DIFF.    =      -1.197
    
```

Report style 3 - tabular output

MOSS  
REPO, ROAD CURVE  
996, KRIG, SLOP, AAST, 3  
999

NORMALS DROPPED FROM POINTS ON STRING LABEL AAST ONTO STRING KRIG

AAST										KRIG		
POINT	X	Y	Z	SLOPE	CROSSFALL	LEVEL	BEARING	POINT	X	Y	Z	
				DIST		DIF						
1	500761.567	111121.321	52.666	62.149	-0.02085	-1.295	156 26 39.6	9-10	500786.399	111064.364	51.371	
2	500793.002	111130.111	51.916	58.648	-0.02042	-1.197	160 14 23.1	8-9	500812.826	111074.928	50.719	
3	500821.311	111150.216	50.211	70.069	-0.00023	-0.016	163 15 43.5	8-9	500841.491	111083.115	50.195	
4	500910.561	111192.873	48.739	68.095	0.00616	0.419	143 22 52.3	6-7	500951.178	111138.220	49.158	
5	500989.147	111292.666	46.829	65.456	-0.00102	-0.067	94 52 23.8	4-5	501054.366	111287.105	46.762	
6	501008.010	111351.967	45.774	55.358	-0.00148	-0.082	107 14 5.2	3-4	501060.882	111335.565	45.692	
7	501050.163	111441.419	44.659	53.208	0.00011	0.006	117 14 12.9	2-3	501097.471	111417.067	44.665	
8	501052.731	111482.113	44.799	69.557	-0.00509	-0.354	116 6 10.9	1-2	501115.193	111451.509	44.445	

## Minor option 997 Intersection of 2 strings

Reports the points of intersection of two strings. To minimise the processing a starting point may be specified on both strings and the search for the intersection will proceed from those points. Curve fitting is invoked automatically to give appropriate accuracy for curved strings. Option 017 may be used to switch off curve fitting.

If a second model name is typed for the major option, this second model is used to find the second string typed on the 997 record.

### Input

### Graphics

REP002, REP010

REPORT minor options	Intersection of 2 strings
Distance and bearing	Intersecting string 1
Distance & brg (normal)	Intersecting string 2
Intersection of 2 strings	Start chainage / X coord
Normal intersections	Start point no. / Y coord
Triangles	Intersection number
Check record pointers	End chainage / X coord
Check for loops in string	End point no. / Y coord
Print format information	
Model file records used	
End REPORT	

Linemode

Minor option 997

- Field 1 First string label; this string must be in the first model typed on the REPORT major option card.
- \* Field 2 Second string label; if two model names are typed on the major option record, this string must be in the second model.
- Field 5 & 6 SPRD for start point on first string.
- Field 7 Intersection number required, if omitted all will be printed.
- Field 8 & 9 SPRD for start point on second string.

◇ *Where there are several points of intersection on the two strings the sequence in which they are output is taken from the first string moving in the direction in which the string is stored.*

Output

```

997BOXXVEEEE
                                                    W147 CURVE FITTING INVOKED

POINTS OF INTERSECTION OF STRING BOXX WITH STRING VEEE
LABEL  POINT      ----X-----  ----Y-----  ---Z----
BOXX   2-3          7.05551      6.06250     1000.000
VEEEE  2-3          7.05551      6.06250     1000.000
BOXX   4-5          5.94449      6.06250     1000.000
VEEEE  1-2          5.94449      6.06250     1000.000

```

Minor option 998 Normals from a string (Normal intersections)

At each point on the reference string a normal is erected and, once an intersection is found, the offset, slope distance and crossfall are reported.

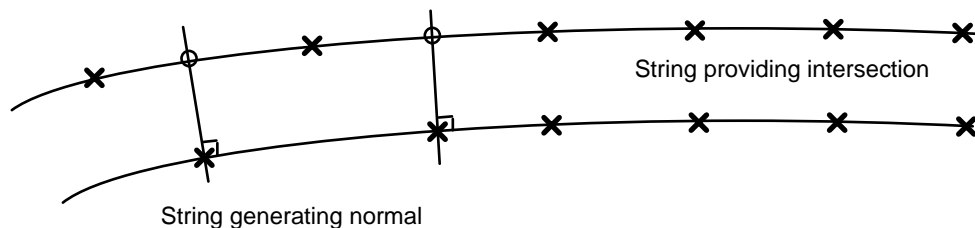


Figure 4 - 42 Example - normal intersections

Minor option 998 also evaluates the level and lateral differences between strings and may be used to assess the accuracy of model data prepared by DIGIT, SURVEY or GENIO. This is described in Chapter 5.

The maximum length of normal is known as the Section Offset Tolerance. It has a default value of 100 units, you may change this value using Global Minor option 017.

Curve fitting is invoked automatically to allow accurate calculation of the point of intersection on curved strings. Option 017 may be used to switch off curve fitting if required.

◇ *Curve fitting cannot be turned off with this minor option.*

**Input**

**Graphics**

REP002, REP011, REP012

REPORT minor options	Normal intersections	Normal intersection points
Distance and bearing	Normal intersection points	Reference string label
Distance & brg (normal)	Level & string differences	Intersecting string
Intersection of 2 strings	End REPORT	Start chainage / X coord
Normal intersections	Report normal intersection	Start point no. / Y coord
Triangles	Single normal onto string	Single point (T)
Check record pointers	Multiple normals onto str	End chainage / X coord
Check for loops in string	Normal(s) from a string	End point no. / Y coord
Piste format information	String differences	
Model file records used	End REPORT	
End REPORT		

**Single point:** Toggle to 1.0 if the normal is required at only 1 point.

REP002, REP011, REP013

REPORT minor options	Normal intersections	Level & string differences
Distance and bearing	Normal intersection points	Reference string label
Distance & brg (normal)	Level & string differences	Intersecting string
Intersection of 2 strings	End REPORT	Start chainage / X coord
Normal intersections	Report normal intersection	Start point no. / Y coord
Triangles	Single normal onto string	Vertical displacements
Check record pointers	Multiple normals onto str	End chainage / X coord
Check for loops in string	Normal(s) from a string	End point no. / Y coord
Piste format information	String differences	Horizontal displacements
Model file records used	End REPORT	
End REPORT		

**Vertical displacements:** Type significance level (50, 80, 90, 95, 98, or 99). See Chapter 5 for further details.

**Horizontal displacements:** Type significance level (50, 80, 90, 95, 98 or 99). See Chapter 5 for further details.

Linemode

Minor option 998

- Field 1 Reference string, from which normal is erected. This string must be in the first model typed at the REPORT major option.
- \* Field 2 String to be intersected by normal
- Field 4 If the normal is required at only 1 point type 1.0.
- Field 5 & 6 SPRD for start point of reference string where normal is erected.
- Field 7 Significance level for vertical differences.  
(Only appropriate for evaluation of displacement between strings - see Chapter 5.)  
Values used may be 50, 80, 90, 95, 98 or 99.
- Field 8 & 9 SPRD for end point of reference string where normal is erected.
- Field 10 Significance level for horizontal displacement.

Output

```

REPO>998,MAC2,CRIG
998MAC2CRIG

POINT OF INTERSECTION OF NORMAL FROM STRING MAC2 WITH STRING CRIG
LABEL POINT -----X----- -----Y----- ---Z--- ----C----- ----B--- ----R--
MAC2 1(EXACT) 501273.64206 111180.18436 66.357 0.000 172 1 1.3 20.000
NO ASSOC POINT IN RANGE -100.000 - 100.000 OF 501273.642 111180.184 ON MAC2

POINT OF INTERSECTION OF NORMAL FROM STRING MAC2 WITH STRING CRIG
LABEL POINT -----X----- -----Y----- ---Z--- ----C----- ----B--- ----R--
MAC2 2(EXACT) 501273.83382 111177.69336 66.123 2.500 179 10 44.4 20.000
CRIG 17-18 501368.78765 111179.05406 58.008
PLAN DISTANCE = 94.964
SLOPE DISTANCE = 95.310
CROSSFALL = -0.0854593
LEVEL DIFF. = -8.116

POINT OF INTERSECTION OF NORMAL FROM STRING MAC2 WITH STRING CRIG
LABEL POINT -----X----- -----Y----- ---Z--- ----C----- ----B--- ----R--
MAC2 3(EXACT) 501273.71352 111175.19789 65.948 5.000 186 20 27.5 20.000
CRIG 21-22 501328.41082 111169.11965 61.157
PLAN DISTANCE = 55.034
SLOPE DISTANCE = 55.242
CROSSFALL = -0.0870477
LEVEL DIFF. = -4.791

POINT OF INTERSECTION OF NORMAL FROM STRING MAC2 WITH STRING CRIG
LABEL POINT -----X----- -----Y----- ---Z--- ----C----- ----B--- ----R--
MAC2 4(EXACT) 501273.28303 111172.73688 65.827 7.500 193 30 10.6 20.000
CRIG 24-25 501306.44614 111164.77332 62.843
PLAN DISTANCE = 34.106
SLOPE DISTANCE = 34.236
CROSSFALL = -0.0874941
LEVEL DIFF. = -2.984

```

## Major option COPY

COPY copies or transfers information from one model to another, and can also be used to copy or move strings within a model.

The copy options available are -

- Simple move/copy (available in graphics only)
- 059** Transformations
- 060** Copy from one model to another. Boundaries may be applied. Existing selection masks and transformations will be applied.
- 061** Transfer from one model to another. This option is identical to option 060 but deletes from the sending model any information transferred. Boundaries may not be applied.
- 064** Copy from one model to another, applying curve fitting to the copied model information. Selection masks may be applied, but boundaries and transformations are not applied.
- 065** Transfer from one model to another, applying curve fitting. This option is identical to 064 but deletes from the sending model any information transferred.
- 066** Copy triangulation from one model to another.

◇ *Only options 059, 060 and 061 will recognise and operate on a casdastre string.*

The normal sequence is -

The strings you wish to copy can be manipulated into modified form by:

- applying a scaling and translation transformation
- applying a rotation and translation transformation
- applying a HELMERT least squares transformation
- applying a TILT transformation
- applying curve fitting to the strings.

◇ *Where strings are copied into a model that already has strings of the same name, the new strings are relabelled according to the standard labelling conventions.*

The copy option can be made selective by:

- selecting strings according to a selection mask
- selecting strings using a partial label

COPY will occur when you run option 060, 061, 064, 065 or 066.

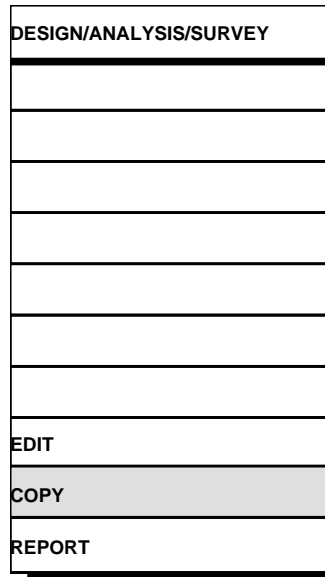
COPY can be used at any stage of a scheme's design. For example:

- in converting a locally produced ground survey to tie in with a larger model, perhaps already held on a national grid basis
- in transferring design information from one model to another for combined analysis



- in merging a design and existing model to analyse the proposed final project.

## Access to major option COPY



Major option COPY is available in several Graphic option menus. If you select COPY you will see this display -

## Models for COPY

### Input

#### Graphics

IGCOPT.DAT, COP001, COP002

Model for COPY	COPY minor options
Model to copy from	Define system parameters
Model to copy to	Define linear units
	Define string masking
	Simple move/copy
	Copy transformations
	Copy strings
	Move strings
	Copy strings with <i>c/f</i>
	Move strings with <i>c/f</i>
	Copy triangulation string

When the model information is correct select PROCEED. The COPY minor options menu will be displayed. Each minor option is dealt with in the following sections.

### Linemode

COPY is a general purpose major option and accepts data in the standard minor option format.

Major option COPY

Model 1 COPY takes string data from model 1 and stores it in model 2.

Model 2 If a boundary string is being referenced, the program will look for it first in model 2 and, if unsuccessful, in model 1.

- ◇ *Global options 000, 017, 018, 019, 900, and 999 can be issued in COPY*
- ◇ *You can restrict the model content being analysed by applying minor option 019.*

## Minor option 017 Define system parameters

IGCOPT.DAT, COP002, COP014, COP014

COPY minor options	Define system parameters	Define system parameters
Define system parameters	Curve fitting status (T)	Survey station str label
Define linear units	Input coord notation (T)	Secondary interp tolerance
Define string masking	Angular input units (T)	Point search tolerance
Simple move/copy	English/French design (T)	Left section offset tol.
Copy transformations	Triangle error echo (T)	Section baseline bearing
Copy strings	Triangle FLAT/NOFL (T)	Secondary interp offset
Move strings	French road type (T)	Right section offset tol.
Copy strings with c/f	Output coord notation (T)	
Move strings with c/f	Angular output units (T)	
Copy triangulation string	Survey station str label	

## Minor option 019 Define string masking

Minor option 019 allows you to include or exclude strings by applying a string or subreference selection mask.

IGCOPT.DAT, COP002, COP008

COPY minor options	Define string masking
Define system parameters	Mask label
Define linear units	Include/exclude/reset (T)
Define string masking	
Simple move/copy	
Copy transformations	
Copy strings	
Move strings	
Copy strings with <i>c/f</i>	
Move strings with <i>c/f</i>	
Copy triangulation string	

## Simple move/copy

Moves or copies strings, allowing a translation or rotation to be applied. The strings may be moved or copied within the same model, or to a different model.

This option is available in graphics only.

Input

Graphics

IGCOPT.DAT, COP002, COP018

COPY minor options	Simple move/copy
Define system parameters	Copy/move (T)
Define linear units	Partial string label
Define string masking	Ref pt X/Y
Simple move/copy	Rotate anticlockwise
Copy transformations	Rotate clockwise
Copy strings	Rotation angle increment
Move strings	Brg ref pt X/Y
Copy strings with c/f	Bearing
Move strings with c/f	Re-draw upon Proceed (T)
Copy triangulation string	

**Copy/move** is a toggle which determines whether the selected strings are moved or copied.

**Partial string label** determines the strings to be moved or copied.

**Ref pt X/Y** is a reference point which determines the axis of rotation and the distance by which the strings are to be translated.

The first time the reference point is specified, the initial position of the strings is set up. If the reference point is specified again, the string(s) are immediately translated by a shift equal to the difference between the previous and current reference points. The axis of rotation is always the current reference point.

To redefine the initial position of the strings, select Quit and respecify the reference point.

**Rotate anticlockwise** rotates the selected strings by the rotation angle increment in an anticlockwise direction. The strings are rotated about the axis determined by the reference point.

**Rotation angle increment** is the number of angular units by which the strings are rotated.

**Rotate clockwise** rotates the selected strings by the rotation angle increment in a clockwise direction. The strings are rotated about the axis determined by the reference point.

**Brg ref pt X/Y** determines the point to which bearings are measured from the reference point.

**Bearing** is the bearing of the bearing reference point from the reference point.

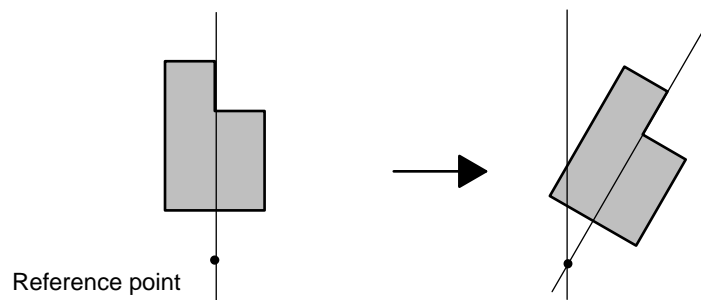
**Re-draw** is a toggle which is used to determine whether strings which have been moved or copied are re-drawn when you select Proceed. This facility is particularly useful when strings are copied to another model and do not change position in the model which is currently displayed.

In either case, strings affected by individual move or copy operations are redrawn temporarily so that the results may be checked.

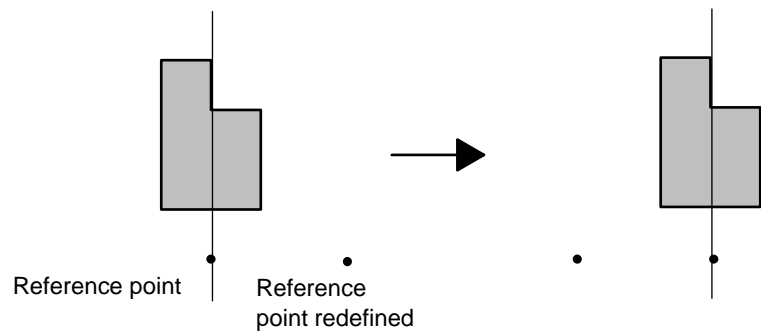
Select Proceed to perform the move or copy operation according to the value of the 'Copy/move' toggle.

Select Quit or Clear to clear the transformations and return the strings to their original position.

Rotation by angle



Translation



Rotation by bearing (90o)

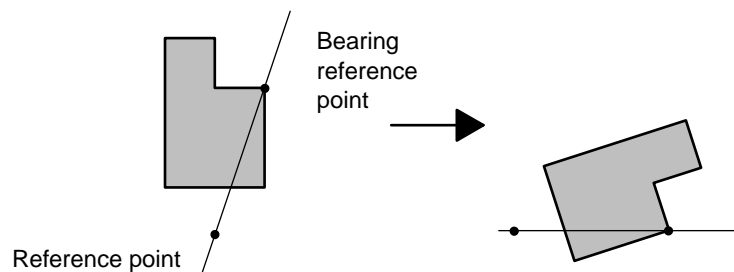


Figure 4 - 43 Simple move/copy

## Minor option 059 Transformations

Minor option 059 allows you to set up five different transformations, prior to using COPY minor options 060 and 061. You can achieve complex transformations by stacking several 059 options prior to using COPY minor options 060 and 061. The transformations available are -

- Scaling
  - Rotation
  - Helmert  
HELMert defines a least squares transformation, similar to IDIGIT.
  - Tilt  
TILT will amend the levels of strings according to a difference plane defined by three control points.
  - Mirror  
Reflects strings about an X, Y or user-defined axis.
- ◇ *SCALing, ROTAtional and MIRRor transformations can be combined (up to a maximum of 100).*
  - ◇ *Transformations will be applied in the order in which they are presented to COPY.*
  - ◇ *All strings above three dimensions can only have a scaling factor applied if the X and Y scaling factors are identical.*
  - ◇ *Null levels and radii of infinity are unaffected by transformation.*
  - ◇ *Cadastre strings - the X, Y, and Z coordinates of cadastre strings subject to rotation, translation, scaling or tilt will be changed. The symbol reference bearing of a cadastre string subject to rotation will be changed only if the string sub reference is NORT. MIRROR transformation of cadastre strings is not permitted.*

## Scaling and translation

### Input

#### Graphics

IGCOPT.DAT, COP002, COP003, COP009

COPY minor option:	COPY transformations	Scaling and translation
Define system parameter:	Scaling and translation	Transformation selected
Define linear unit:	Rotation and translation	X scale factor
Define string maskin:	Helmert transformation	Y scale factor
Simple move/copy	Tilt (coordinates)	Z scale factor
Copy transformation:	Tilt (string point)	X displacement
Copy strings	Mirror transformation	Y displacement
Move strings	Reset transformation	Z displacement
Copy strings with c/		
Move strings with c/		
Copy triangulation string		

### Linemode

#### Set up SCALING transformation

##### Minor option 059

- Field 1      SCAL
- Field 4      Dimension to be scaled (optional)
  - 1 = X
  - 2 = Y
  - or 3 = Z etc.
- Field 5      Scaling factor for X values (SCALEX) or  
Scaling factor of field 4 dimension (SCALE)
- Field 6      Scaling factor for Y values (SCALEY)
- Field 7      Scaling factor for Z values (SCALEZ)
- Field 8      X displacement (XDISP) or  
Displacement of field 4 dimension (DISP)
- Field 9      Y displacement (YDISP)
- Field 10     Z displacement (ZDISP)

Assuming Field 4 is left blank then the transformation applied is

$$\begin{aligned}
 X_{NEW} &= SCALEX * X_{OLD} + XDISP \\
 Y_{NEW} &= SCALEY * Y_{OLD} + YDISP \\
 Z_{NEW} &= SCALEZ * Z_{OLD} + ZDISP
 \end{aligned}$$



If field 4 is coded then fields 5 and 8 define the transformation to be applied to the appropriate dimension

$$\text{NEWVALUE} = \text{SCALE} * \text{OLDVALUE} + \text{DISP}$$

- ◇ *Multiple SCAL options may be coded for complex transformations.*
- ◇ *The SCAL option can be combined with ROTA and MIRR options.*
- ◇ *All strings above three dimensions can only have a scaling factor applied if the X and Y scaling factors are identical*
- ◇ *SCALEX and SCALEY must be greater than zero.*
- ◇ *Care should be taken to ensure meaningful results when dimensions other than X, Y and Z are individually scaled or displaced.*

## Rotation and translation

### Input

#### Graphics

IGCOPT.DAT, COP002, COP003, COP010

COPY minor option:	COPY transformations	Rotation and translation
Define system parameter:	Scaling and translation	Transformation selected
Define linear unit:	Rotation and translation	Angle of rotation
Define string maskin	Helmert transformation	Old X Coordinate
Simple move/copy	Tilt (coordinates)	Old Y Coordinate
Copy transformation:	Tilt (string point)	New X Coordinate
Copy strings	Mirror transformation	New Y Coordinate
Move strings	Reset transformation	
Copy strings with c/		
Move strings with c/		
Copy triangulation strin		

### Linemode

#### Set up ROTATION transformation

##### Minor option 059

Field 1      ROTA

Field 3      String label defining common point (optional)

Field 4      ANGLE Whole circle bearing of new Y axis from existing Y axis.

- \* Field 5 & 6      Coordinates of common point on old grid or SPRD of point on string in field 3 XCPOLD, YCPOLD

- \* Field 8 & 9 Coordinates of common point on new grid XCPNEW, YCPNEW

- ◇ *Multiple ROTA options may be coded for complex transformations.*
- ◇ *The ROTA option can be combined with SCAL and MIRR options*

Values of the common point (XCPOLD, YCPOLD, XCPNEW, YCPNEW) and ANGLE are substituted in the following equation to determine the displacement (XDISP, YDISP) between the original and new origin values.

$$XDISP = XCPNEW - XCPOLD * \cos(\text{ANGLE}) + YCPOLD * \sin(\text{ANGLE})$$

$$YDISP = YCPNEW - XCPOLD * \sin(\text{ANGLE}) - YCPOLD * \cos(\text{ANGLE})$$

The transformation applied is now given by:

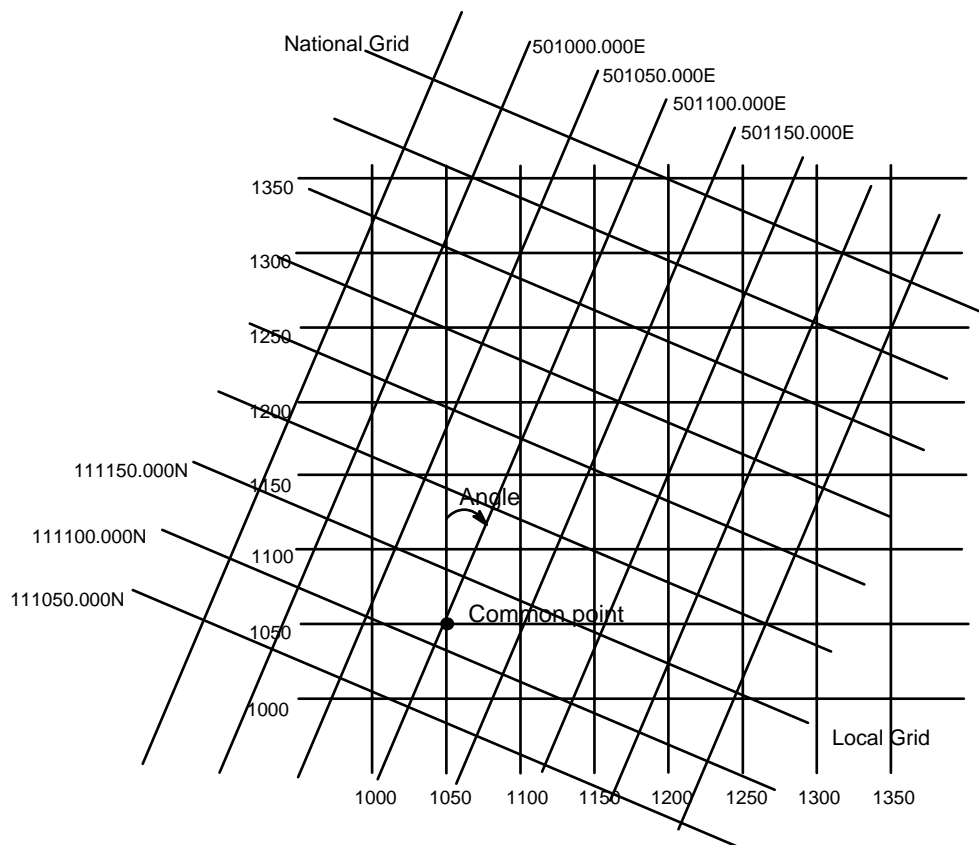
$$XNEW = XOLD * \cos(\text{ANGLE}) - YOLD * \sin(\text{ANGLE}) + XDISP$$

$$YNEW = XOLD * \sin(\text{ANGLE}) + YOLD * \cos(\text{ANGLE}) + YDISP$$

**Example**

A model based upon a local site grid needs transforming onto a national grid co-ordinate system. National grid north is at a whole circle bearing of 23.5 degrees on the local grid.

The ROTATION transformation is used to do this.



**Figure 4 - 44 Example of rotation**

It is known that 1050E, 1050N on the local grid will correspond to 501100.000E, 111120.000N on the national grid. There are no scale factors to be accounted for.

XCPOLD = 1050  
YCPOLD = 1050  
XCPNEW = 501100.000  
YCPNEW = 111120.000

These values can now be used in option 059 in fields 5 and 6 and 8 and 9 to transform the model from the local to the national grid. For example:

```
059,ROTA,4=233000,5=1050,6=1050,8=501100.000,9=111120.000
060
999
```

◇ *Default ANGLE input (field 4) is Degrees, Minutes, Seconds (DMS)*

## HELMERT transformation

### Input

### Graphics

IGCOPT.DAT, COP002, COP003, COP011

COPY minor options	COPY transformations	Helmert transformation
Define system parameters	Scaling and translation	Transformation selected
Define linear units	Rotation and translation	Residual tolerance
Define string masking	Helmert transformation	Old X coordinate
Simple move/copy	Tilt (coordinates)	Old Y coordinate
Copy transformations	Tilt (string point)	New X coordinate
Copy strings	Mirror transformation	New Y coordinate
Move strings	Reset transformation	
Copy strings with c/f		
Move strings with c/f		
Copy triangulation string		

### Linemode

#### Set up HELMERT transformation

##### Minor option 059

Field 1 HELM  
Field 3 String label defining common point (optional)  
Field 4 Tolerance in residual coordinate errors, dx and dy, for the transformed position of the control points

- Only needed on 1st 059 record
- Default value = 1.0 (model units)
- \* Field 5 & 6 Coordinates of common point on old grid or SPRD of point on string in field 3
- \* Field 8 & 9 Coordinates of common point on new grid.
  - ◇ *A minimum of two and a maximum of ten 059 options are needed to provide the necessary control point information.*
  - ◇ *The HELM option cannot be combined with other options.*

## TILT transformation

### Input

### Graphics

IGCOPT.DAT, COP002, COP003, COP012

COPY minor options	COPY transformations	Tilt (coordinates)
Define system parameters	Scaling and translation	Transformation selected
Define linear units	Rotation and translation	X coordinate
Define string masking	Helmert transformation	Y coordinate
Simple move/copy	Tilt (coordinates)	Level difference
Copy transformations	Tilt (string point)	
Copy strings	Mirror transformation	
Move strings	Reset transformation	
Copy strings with c/f		
Move strings with c/f		
Copy triangulation string		

IGCOPT.DAT, COP002, COP003, COP013

COPY minor option:	COPY transformations	Tilt (string point)
Define system parameter:	Scaling and translation	Transformation selected
Define linear unit:	Rotation and translation	String label
Define string maskinç	Helmert transformation	Chainage /X coordinate
Simple move/copy	Tilt (coordinates)	Point no /Y coordinate
Copy transformation:	Tilt (string point)	New level
Copy strings	Mirror transformation	
Move strings	Reset transformation	
Copy strings with c/		
Move strings with c/		
Copy triangulation string		

Linemode

**Set up TILT transformation**

Minor option 059

- Field 1 TILT
- Field 3 String label defining reference point (optional)
- \* Field 5 & 6 Coordinates of reference point on old grid or SPRD of point on string in field 3
- Field 7 New level (optional)
- Field 10 Level difference (optional).
- ◇ *Exactly three 059 options are needed to provide the necessary control point information.*
- ◇ *The TILT option cannot be combined with other options*
- ◇ *Either Field 7 or Field 10, but not both, must be coded.*
- ◇ *2D contour strings are converted to 3D strings.*
- ◇ *TILT is only a vertical transformation and no change is made to X and Y coordinates.*
- ◇ *ensure correct selection of model before applying TILT. For example if applied to a highway design, design criteria will be invalidated.*
- ◇ *When using Field 7 to define a new level, a point from an existing string must be specified.*

Example

```
059, TILT, 5=X1, 6=Y1, 10=-5
059, TILT, 5=X2, 6=Y2, 10=-15
059, TILT, 5=X3, 6=Y3, 10=-10
```

060  
999

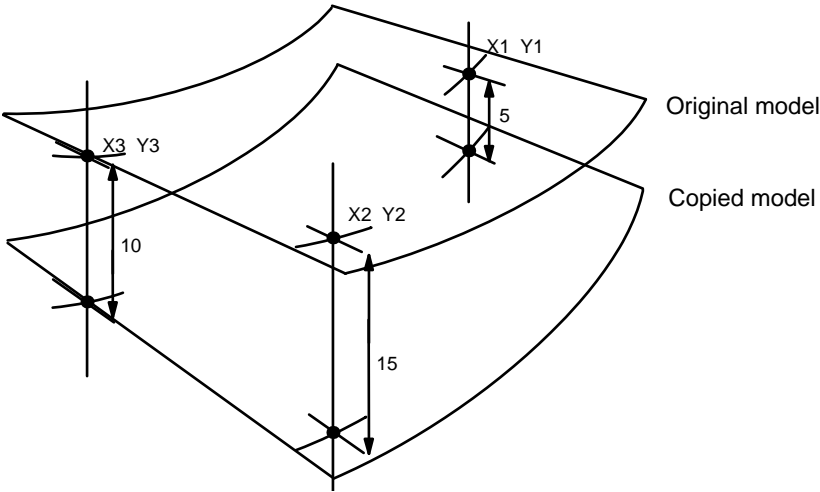


Figure 4 - 45 Example showing TILT transformation

# MIRROR transformation

## Input

### Graphics

IGCOPT.DAT, COP002, COP003, COP017

COPY minor options	COPY transformations	Mirror transformation
Define system parameters	Scaling and translation	Transformation selected
Define linear units	Rotation and translation	Axis (T)
Define string masking	Helmert transformation	1st chainage / X coord
Simple move/copy	Tilt (coordinates)	1st point no. / Y coord
Copy transformations	Tilt (string point)	2nd chainage / X coord
Copy strings	Mirror transformation	2nd point no. / Y coord
Move strings	Reset transformation	
Copy strings with c/f		
Move strings with c/f		
Copy triangulation string		

## Linemode

### Set up MIRROR transformation

#### Minor option 059

- \* Field 1      MIRR
- Field 2      First reference string label  
This defines the string through which the axis of reflection is to pass.
- Field 3      Second reference string label  
If the axis of reflection is not an X or Y axis, this defines the second string through which the axis is to pass.
- Field 4      Axis of reflection
  - 1          X axis (default)
  - 2          Y axis
  - 3          user defined axis
- \* Field 5 & 6    SPRD of point on first reference string through which the axis is to pass.  
-If no reference string is specified in Field 2, any coordinate position may be specified.
- Field 8 & 9    SPRD of point on second reference string through which the axis is to pass.

If no reference string is specified in Field 3, any coordinate position may be specified.

- ◇ *The MIRR option can be combined with SCAL and ROTA options*



Example 1

This example sets up a mirror transformation about a in the Y axis through point 5 on reference string REFS.

059 ,MIRR ,REFS , 4=2 , 6=5

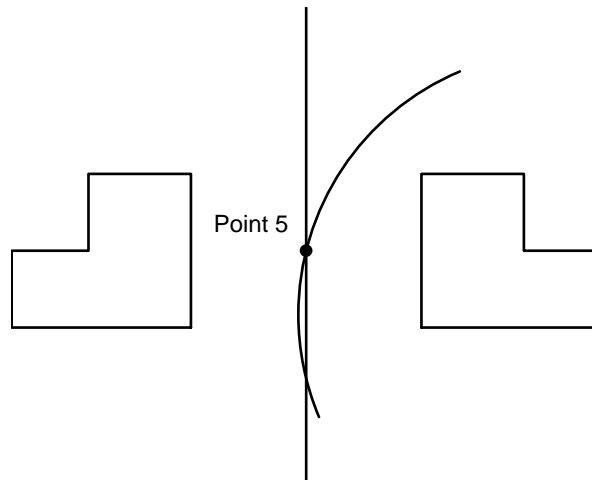


Figure 4 - 46 Mirror transformation in Y axis

Example 2

This example sets up a mirror transformation about a user defined axis which passes through the points (2178, 5193), (1987, 5327)

059 ,MIRR , 4=3 , 2178 , 5193 , 8=1987 , 5327

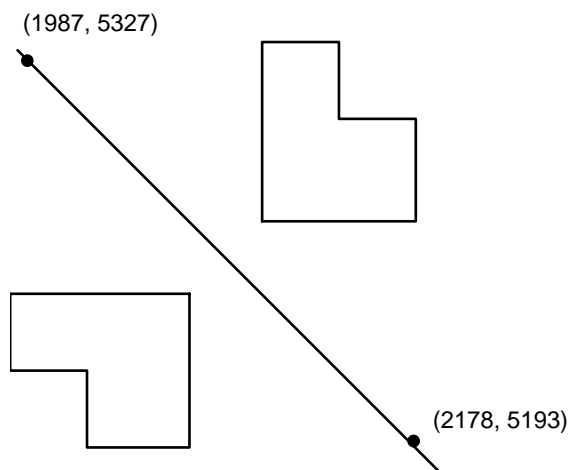


Figure 4 - 47 Mirror about a user defined axis

## Cancel existing transformations

### Input

#### Graphics

IGCOPT.DAT, COP003

<b>COPY transformations</b>
Scaling and translation
Rotation and translation
Helmert transformation
Tilt (coordinates)
Tilt (string point)
Mirror transformation
Reset transformation

### Linemode

#### Cancel existing transformations

Minor option 059

All fields must be left blank

### Minor option 060 Copy strings

COPY from one model to another. Boundaries may all be applied. Existing selection masks and transformations will be applied.

Input

Graphics

IGCOPT.DAT, COP002, COP004

COPY minor options	Copy strings
Define system parameters	String label to be copied
Define linear units	IN/OUT (T)
Define string masking	Boundary string label
Simple move/copy	Re-draw option (T)
Copy transformations	
Copy strings	
Move strings	
Copy strings with c/f	
Move strings with c/f	
Copy triangulation string	

- ◇ *In COPY 060 any transformation valid in COPY 059 will be applied to each selected point. This is defined relative to the coordinate axes, and may be used for transforming from one grid to another.*

Linemode

Minor option 060

Field 1 Label or partial label of string to be copied (if left blank all strings are copied)

Field 2 IN/OUT indicator  
Leave blank to copy inside the boundary  
Type OUT to copy outside the boundary

Field 3 Boundary string label

- ◇ *If you type a string label or a partial label, any masks table will be ignored.*
- ◇ *No curve fitting is applied in finding intersections with boundaries.*
- ◇ *P strings and text strings (\*) are not interpolated at boundaries.*
- ◇ *Cadastre strings - where a boundary is specified only the points included by the IN/OUT definition will be copied.*
- ◇ *Where the receiving model has strings with the same label as the new strings, the new strings are automatically relabelled.*
- ◇ *Cadastre strings - the X, Y, and Z coordinates of cadastre strings subject to rotation, translation, scaling or tilt will be changed. The symbol reference bearing of a cadastre string subject to rotation will be changed only if the string sub reference is NORT. MIRROR transformation of cadastre strings is not permitted.*

## Minor option 061 Move strings

Transfer from one model to another. This option is identical to option 060 but deletes from the sending model any information transferred. Boundaries may not be applied.

### Input

#### Graphics

IGCOPT.DAT, COP002, COP005

COPY minor options	Move strings
Define system parameters	String label to transfer
Define linear units	Re-draw option (T)
Define string masking	
Simple move/copy	
Copy transformations	
Copy strings	
Move strings	
Copy strings with c/f	
Move strings with c/f	
Copy triangulation string	

- ◇ *If the sending model is displayed and the re-draw option is set to YES, information will be deleted from the display as it is deleted from the sending model.*
- ◇ *If the sending and receiving models are displayed and the re-draw option is set to YES, information will be deleted from the display as it is deleted from the sending model and re-drawn when it is received at the destination model.*
- ◇ *In COPY 061 any transformation valid in COPY 059 will be applied to each selected point. This is defined relative to the coordinate axes, and may be used for transforming from one grid to another.*

### Linemode

#### Minor option 061

Field 1 Label or partial label of string to be copied (if left blank all strings are copied)

- ◇ *If you type a string label or a partial string label, any masks table will be ignored.*
- ◇ *Cadastre strings. The X, Y, and Z coordinates of cadastre strings subject to rotation, translation, scaling or tilt will be changed. The symbol*

*reference bearing of a cadastre string subject to rotation will be changed only if the string sub reference is NORT. MIRROR transformation of cadastre strings is not permitted.*

- ◇ *Where the receiving model has strings with the same label as the new strings, the new strings are automatically relabelled.*

## Minor option 064 Copy strings with curve fitting

COPY from one model to another, applying curve fitting to the copied model information. Selection masks may be applied, but boundaries and transformation are not applied.

### Input

Graphics

Graphics

IGCOPT.DAT, COP002, COP006

COPY minor options	Copy strings with c/f
Define system parameters	String label to be copied
Define linear units	Curve fitting (T)
Define string masking	Chord to arc tolerance
Simple move/copy	Re-draw option (T)
Copy transformations	
Copy strings	
Move strings	
Copy strings with c/f	
Move strings with c/f	
Copy triangulation string	

Linemode

Minor option 064

Field 1	Label or partial label of string to be copied (if left blank all strings are copied)
Field 2	Curve fitting style MOSS invokes MOSS curve fitting and this is the default. SPLI invokes SPLINE curve fitting
Field 4	Curve fittingChord-to-arc tolerance. The default chord-to-arc tolerance is determined by the variable AHDETOLR in the parameter file.Default value. @@@@e is 0.1 model units

Curve fit style

Curve fit style

The curve fit style is either the MOSS style or SPLINE.

The MOSS style of curve fitting is based on circular arcs whose radii vary linearly from point to point along the string.

The SPLINE style of curve fitting applies a local spline between pairs of points so that tangential continuity is maintained throughout the string.

Curve fit toleranceChord-to-arc tolerance

The curve fit tolerancThe chord-to-arc tolerance defines the maximum chord to arc tolerancedistance between the chord and arc of a circle which is acceptable before further points are added. A typical value, in model units would be 0.1.

Curve fitting is as follows:

- P strings are not curve fitted
- \* (text) strings are not curve fitted
- Cadastre strings are not curve fitted
- Cross-section strings are not curve fitted
- Interface strings are curve fitted but dimensions above the second are linearly interpolated
- 6D M-strings are curve fitted but the third dimension (level) and fourth dimension (chainage) are linearly interpolated.

Strings other than those above have their first two dimensions curve fitted.

- ◇ *This option does not select within or outside a boundary, nor apply a transformation. Use option 059/060/061 first.*
- ◇ *For all curve fit strings the third dimension of inserted points is always linearly interpolated.*
- ◇ *The generated string will be produced independently of any other strings in the model. Consequently if two adjacent strings are nearly parallel without curve fitting their curve fit representations may not necessarily*

*appear parallel and they may in fact intersect. This may occur if you curve fit contours to achieve smoother strings.*

## Minor option 065 Move strings with curve fitting

Transfer from one model to another, applying curve fitting. This option is identical to option 064 but deletes from the sending model any information transferred.

### Input

#### Graphics

IGCOPT.DAT, COP002, COP007

COPY minor options	Move strings with c/f
Define system parameters	String label to transfer
Define linear units	Curve fitting (T)
Define string masking	Chord to arc tolerance
Simple move/copy	Re-draw option (T)
Copy transformations	
Copy strings	
Move strings	
Copy strings with c/f	
Move strings with c/f	
Copy triangulation string	

- ◇ *If the sending model is displayed and the re-draw option is set to YES, information will be deleted from the display as it is deleted from the sending model.*
- ◇ *If the sending and receiving models are displayed and the re-draw option is set to YES, information will be deleted from the display as it is deleted from the sending model and re-drawn when it is received at the destination model.*

### Linemode

#### Minor option 065

- Field 1 Label or partial label of string to be copied (if left blank all strings are copied)
- Field 2 Curve fitting style

	MOSS	invokes MOSS curve fitting and this is the default.
	SPLI	invokes SPLINE curve fitting
Field 4	Curve fitting	Chord-to-arc tolerance.
		The default chord-to-arc tolerance is determined by the variable AHDETOLR in the parameter file. Default value is 0.1 model units

### Curve fit style

The curve fit style is either the MOSS style or SPLINE.

The MOSS style of curve fitting is based on circular arcs whose radii vary linearly from point to point along the string.

The SPLINE style of curve fitting applies a local spline between pairs of points so that tangential continuity is maintained throughout the string.

### Chord-to-arc tolerance [curve fit tolerance](#)

The curve fit chord-to-arc tolerance defines the maximum chord to arc tolerance distance between the chord and arc of a circle which is acceptable before further points are added. A typical value, in model units would be 0.1.

Curve fitting is as follows:

- P strings are not curve fitted
- \* (text) strings are not curve fitted
- Cadastre strings are not curve fitted
- Cross-section strings are not curve fitted
- Interface strings are curve fitted but dimensions above the second are linearly interpolated
- 6D M-strings are curve fitted but the third dimension (level) and fourth dimension (chainage) are linearly interpolated.

Strings other than those above have their first two dimensions curve fitted.

- ◇ *By invoking a string label, any masks table will be ignored.*
- ◇ *This option does not select within or outside a boundary, nor apply a transformation. Use option 059/060/061 first.*
- ◇ *For all curve fit strings the third dimension of inserted points is always linearly interpolated.*
- ◇ *The generated string will be produced independently of any other strings in the model. Consequently if two adjacent strings are nearly parallel without curve fitting their curve fit representations may not necessarily appear parallel and they may in fact intersect. This may occur if you curve fit contours to achieve smoother strings.*



## Minor option 066 Copy triangulation string

### Input

### Graphics

IGCOPT.DAT, COP002, COP015

COPY minor options	Copy triangulation string
Define system parameters	String label to be copied
Define linear units	Re-draw option (T)
Define string masking	
Simple move/copy	
Copy transformations	
Copy strings	
Move strings	
Copy strings with c/f	
Move strings with c/f	
Copy triangulation string	

### Linemode

#### Minor option 066

Field 1 Leave blank to copy all triangulations in the model.  
To copy individual strings use full string label.  
To copy groups of strings use partial label.

- ◇ *Triangulation strings can be copied only to existing triangulation models (ie those with a TRIA suffix in the name), or blank models.*

# Major option AREA

The major option AREA is used to calculate the plan or surface area of a model. You define the part of the model whose area is required either by a boundary string or by means of two strings limited in extent by normals to a reference string. You may use any of the following methods:

- 040 Within a boundary string
- 041 Between two strings
- 042 Two intersecting boundaries
- 043 Slope between two strings.

The area, multiplying factor, volume area and crude volume will be displayed in the status display area until you chose another option or exit.

If an error occurs during calculation of the area, no hatching or annotation will be displayed.

## Multiplying factor

By the application of a simple multiplying factor you may use any minor option for the creation of crude volumes such as soiling volumes. You may also use the multiplying factor to effect a change of units.

## Triangulation models

Major option AREA can be used to determine the plan and surface area of a triangulation model created within major option TRIANGLE.

- 045 Triangulation area.

## Section models

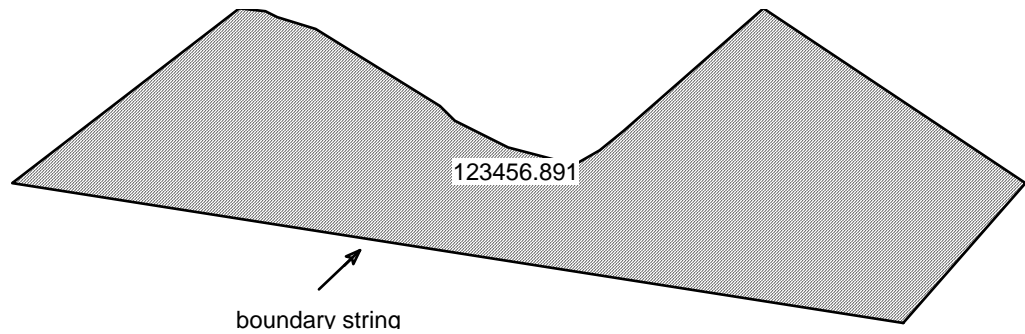
Areas can also be calculated which are based on sections. This approach enables the total slope area, the slope area in cut and the slope area in fill to be determined. Plan areas can also be obtained.

- 046 Section based area extent
- 047 Section based area
- 048 Create area string

## Hatching and annotation

In Graphics mode all the minor options have common default settings for hatching and annotation. Hatching provides visual confirmation that the area intended has been selected. Annotation provides the calculated area value as a text label centred in the area.

◇ *Hatching is not available with section based areas.*



**Figure 4 - 48 Area showing hatching and annotation**

The default hatching specifications are:-

Angle	- zero
Hatching distance	- 0.25
Line colour	- current line colour
Line style	- solid line.

The hatching is defined by the current APPLY FILL/COLOUR attributes, annotation is defined by the current TEXT STYLE/COLOUR attributes, defined in the Static Menu area. You may select the hatching and annotation defaults from -

NONE	No hatching and/or no annotation.
TEMP	Temporary hatching and/or temporary annotation. These will only remain on the screen until you choose another option or exit. As a result you can only temporarily hatch/annotate one area at a time. Temporarily hatched/annotated areas cannot be picked or manipulated in any way.
STORED	Stored hatching and/or stored annotation are stored on the picture file (DPF). You may select, delete, move etc., the hatching/annotation just like any other element. This also means that several areas may be hatched and/or annotated.
RETAIN	Retained hatching and/or retained annotation remain on the screen until the you select another major option or exit.

## Access to major option AREA

### Graphics

Analysis options	Model for AREA	AREA minor options
AREA	Reference model	Define system parameters
TRIANGLE	Boundary/sections model	Define linear units
SECTION	Model to store areas	Define string masking
VOLUME		Within boundary string
SURFACE		Between two strings
PRISM		2 intersecting boundaries
		Slope between two strings
EDIT		Triangulation area
COPY		Section based area
REPORT		End AREA

IGGENLT.DAT, GEN, IGAREAT.DAT, ARE001, ARE002

### Linemode

Major option AREA

Model 1 Reference or triangulation model.

For option 045 this must be a triangulation model type TRIA.

Model 2 Model containing boundary or section strings.

For options 046, 047 and 048 this must be a sections model.

◇ *For option 040 and 042 the boundary strings may be in model 1 or model 2.*

Major option AREA

Model 3 Model to store area string (option 048 only)

## Minor option 040 Within boundary string

### Method of computation

This minor option takes pairs of points in sequence and creates trapezia by dropping perpendiculars to an arbitrary baseline and calculates the area of the figures so formed and accumulates the net area. If the first and last points of the boundary string are not coincident the option closes the string to form an effective boundary.

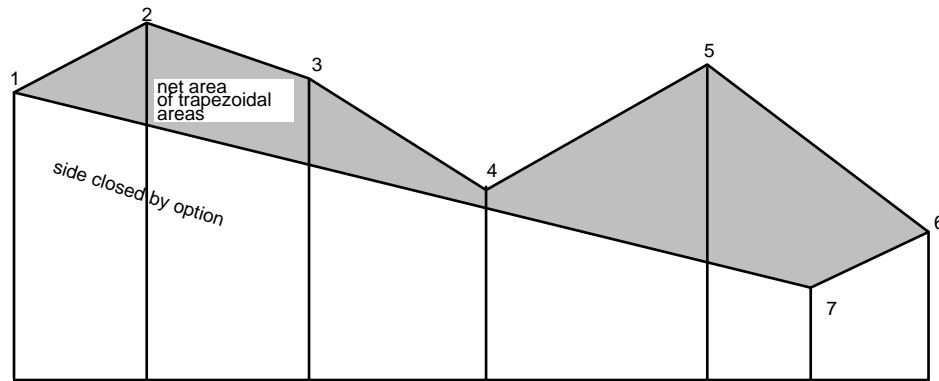


Figure 4 - 49 Plan area, within a boundary string.

Input

Graphics

AREA minor option:	Within boundary string
Define system parameter:	Boundary string label
Define linear units:	Multiplying factor
Define string masking:	Hatching default (T)
Within boundary string:	Annotation default (T)
Between two string:	
2 intersecting boundaries:	
Slope between two string:	
Triangulation area:	
Section based area:	
End AREA	

IGAREAT.DAT, ARE002, ARE003

◇ The multiplying factor will apply a default of 1 unless changed.

Linemode

Minor option 040

- \* Field 3 Label of boundary string.
- Field 4 Multiplying factor to be applied to the resultant area to produce a crude volume. (Optional).

Example

```

AREA          AREA MODEL
040          BOND
PLAN AREA ENCLOSED BY STRING/BOUNDARY 'BOND'
--PLAN AREA--      --FACTOR--      --VOLUME--
20398.291          1.00          20398.291
    
```

```

-----
AREA WITH FACTOR
040          BOND 20.
PLAN AREA ENCLOSED BY STRING/BOUNDARY 'BOND'
  --PLAN AREA--      --FACTOR--      --VOLUME--
20398.291           20.0           407965.821
-----
  
```

## Minor option 041 Between two strings

### Method of computation

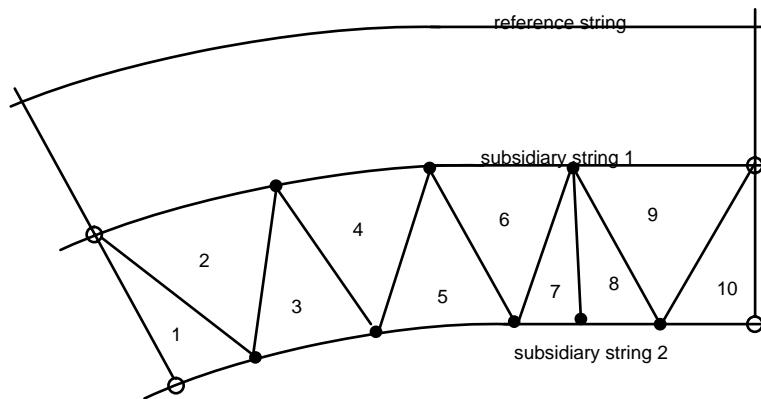


Figure 4 - 50 Plan area between two strings.

Normals are erected on a reference string at specified start and end points to generate associated points on the two subsidiary strings. The polygon formed by the two strings and the normals is divided into triangles taking at least one point from each subsidiary string. The triangle with the shortest third side is chosen from the two possible triangles, shown below.

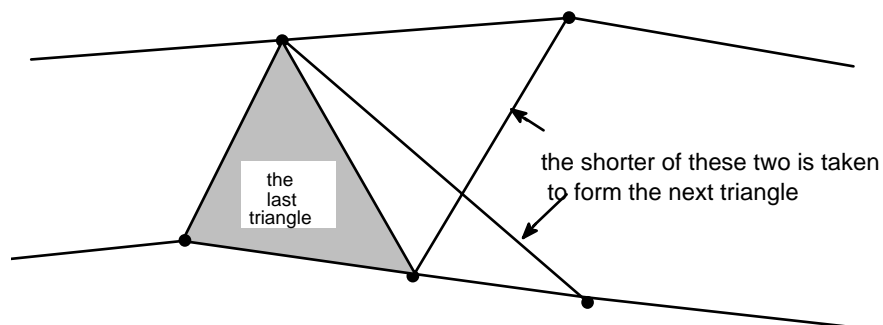


Figure 4 - 51 Next triangle selection.

◇ *The strings must not cross one another or loop back on themselves.*

The area calculated is equal to the sum of the areas of the triangles in the polygon.

Input

Graphics

AREA minor option:	Between two strings
define system parameter:	Reference string label
define linear units:	First subsidiary string
define string maskinç	Second subsidiary string
Within boundary string	Multiplying factor
Between two string:	Start chainage /X coord
intersecting boundarie:	Start point no. /Y coord
slope between two string:	End chainage /X coord
triangulation area:	End point no. /Y coord
ection based area:	Hatching default (T)
end AREA	Annotation default (T)

IGAREAT.DAT, ARE002, ARE004

◇ The multiplying factor will apply a default of 1 unless changed.

Linemode

Minor option 041

- \* Field 1 Reference string.
- \* Field 2 First subsidiary string.
- \* Field 3 Second subsidiary string
- Field 4 Multiplying factor to be applied to the resultant area to produce a crude volume. (Optional).
- Field 5 & 6 SPRD for start point on reference string.
- Field 8 & 9 SPRD for end point on reference string.

Example

```

AREA BETWEEN CHANNELS - PLAN
041 MASTSTR1STR2 30

PLAN AREA BETWEEN STRINGS 'STR1' & 'STR2'
--PLAN AREA-- --FACTOR-- --VOLUME--
6000.000 1.000 6000.000
-----
AND FACTOR
041 MAST STR1STR210.0 30

PLAN AREA BETWEEN STRINGS 'STR1' & 'STR2'
--PLAN AREA-- --FACTOR-- --VOLUME--
6000.000 10.000 60000.000
-----
999
    
```

## Minor option 042 Two intersecting boundaries

### Method of computation

In Figure 4 - 52 (1) a new boundary is formed to enclose the area A and is referred to as the area within boundary 1 and outside boundary 2. In Figure 4 - 52 (2) a new boundary is formed to enclose area B which is referred to as the area inside boundary 1 and boundary 2. The method used for computing the resultant area is the same as that used by option 040.

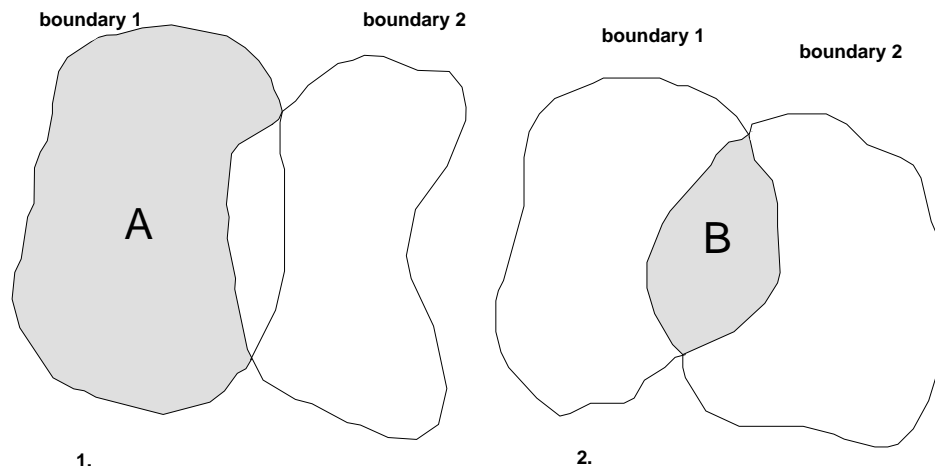


Figure 4 - 52 Plan area formed by two intersecting boundary strings.

### Input

### Graphics

AREA minor option:	2 intersecting boundaries
define system parameter:	First boundary string
define linear units:	IN/OUT (T)
define string maskinç	Second boundary string
Within boundary string	Multiplying factor
between two string:	Hatching default (T)
intersecting boundarie:	Annotation default (T)
slope between two string:	
triangulation areç	
section based areç	
end AREA	



**IGAREAT.DAT, ARE002, ARE005**

- ◇ *The multiplying factor will apply a default of 1 unless changed.*
- ◇ *The two boundary strings must be in the same model.*

Linemode

Minor option 042

- \* Field 1      Label of first boundary string
- Field 2      OUT if area is within boundary 1 and outside boundary 2.  
              IN if area is within boundary 1 and inside boundary 2.
- \* Field 3      Label of second boundary string
- Field 4      Multiplying factor to be applied to the resultant area to produce  
              a crude volume (optional).

Example

```

AREA          AREA MODEL
042 BDY1INBDY21.0

PLAN AREA BETWEEN STRINGS 'BDY1' & 'BDY2'
  --PLAN AREA--  --FACTOR--  --VOLUME--
    6000.000      1.000      6000.000
-----
AND FACTOR
042 BDY1INBDY210.0

PLAN AREA BETWEEN STRINGS 'BDY1' & 'BDY2'
  --PLAN AREA--  --FACTOR--  --VOLUME--
    6000.000     10.000     60000.000
-----
999
  
```

Minor option 043    Slope between two strings

Method of computation

The method of computation used is identical to that used in minor option 041, except that the slope area is calculated. In the simple case a simple slope is assumed to exist from one subsidiary string to the other and any other string information between is ignored.

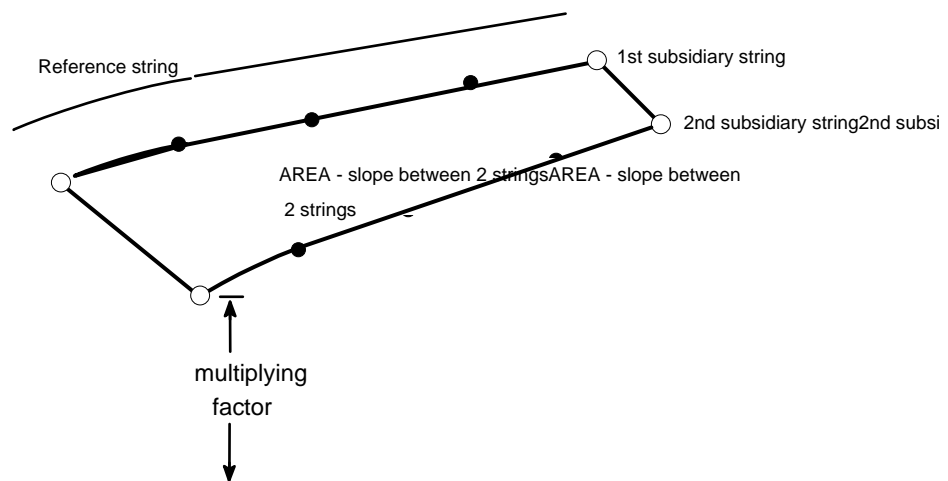


Figure 4 - 53    Slope between two strings

Input

Graphics

AREA minor option:	Slope between two strings
Define system parameter:	Reference string label
Define linear units:	First subsidiary string
Define string masking:	Second subsidiary string
Within boundary string:	Multiplying factor
Between two strings:	Start chainage /X coord
2 intersecting boundaries:	Start point no. /Y coord
Slope between two strings:	End chainage /X coord
Triangulation area:	End point no. /Y coord
Section based area:	Hatching default (T)
End AREA	Annotation default (T)

IGAREAT.DAT, ARE002, ARE004

◇ *The multiplying factor will apply a default of 1 unless changed.*

Linemode

Minor option 043

- \* Field 1 Label of reference string.
- \* Field 2 Label of first subsidiary string.
- \* Field 3 Label of second subsidiary string
- Field 4 Multiplying factor to be applied to the resultant area to produce a crude volume. (Optional).
- Field 5 & 6 SPRD for start point on reference string.
- Field 8 & 9 SPRD for end point on reference string.

Example

```

AREA          AREA MODEL
SLOPE AREA
043 MASTSTR1STR2          300          500
SLOPE AREA BETWEEN STRINGS 'STR1' & 'STR2'
--PLAN AREA--          --FACTOR--          --VOLUME--
6029.925          1.000          6029.925
-----
AND FACTOR
043 MASTSTR1STR210.0          300          500
SLOPE AREA BETWEEN STRINGS 'STR1' & 'STR2'
--PLAN AREA--          --FACTOR--          --VOLUME--
6029.925          10.000          60299.254
-----
999
    
```

## Minor option 045    Triangulation area

This minor option simply calculates the total plan/surface areas of a triangulation model. A boundary string may optionally be used to limit the extent of the calculation. When a boundary string is specified, the centroid of an individual triangle must be inside the boundary string if it is to be included in the calculation of the area.

Triangles to be included in the area calculation may also be selected by group code. See major option TRIANGLE for details of how to group triangles and allocate a group code.

### Input

### Graphics

AREA minor options	Triangulation area
Define system parameters	Group code
Define linear units	Triangulation string
Define string masking	Boundary string label
Within boundary string	Hatching default (T)
Between two strings	Annotation default (T)
2 intersecting boundaries	
Slope between two strings	
Triangulation area	
Section based areas	
End AREA	

IGAREAT.DAT, ARE002, ARE007

### Linemode

#### Minor option 045

Field 1        Group code.

If this is specified, only the area of the associated triangle group is calculated.

\* Field 2        Triangulation string

Field 3        Boundary string.

◇ *Field 3 can only be used if model 2 has been coded.*

◇ *Where both model 1 and model 2 have been coded, the search for the boundary string will take place in model 2 first then in model 1.*

### Example

```
MOSS  
AREA, SIMPLE DESIGN TRIANG  
045, , TSDR  
999
```

```
MOSS  
AREA    SIMPLE DESIGN TRIANG  
045     TSDR  
  
MIN LEVEL =          63.439  
MAX LEVEL =          68.622  
PLAN AREA =          814.519  
SLOPE AREA =         824.493  
999
```

## Minor option 046/47/48 Section based area

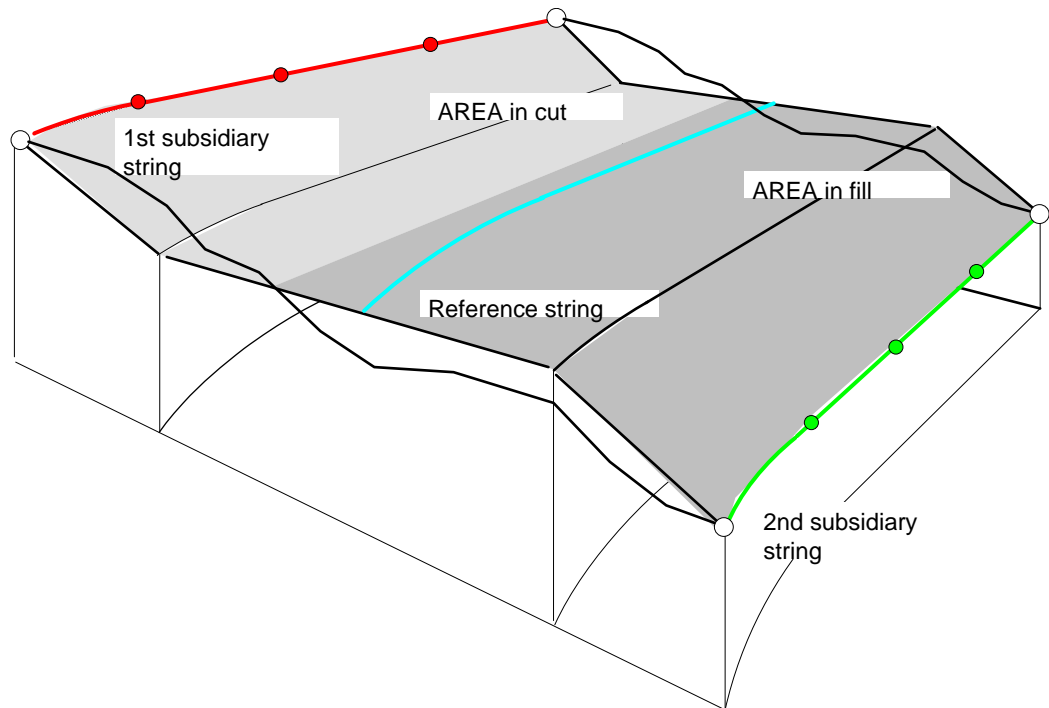
Minor option 046 defines the extents of the areas to be calculated by minor option 047, 'Section based area'. The extents are defined in a similar way to minor options 041 and 043.

Minor option 047 calculates the slope or plan area between the extents defined by minor option 046. Areas are calculated by using sections and can be given as a total area or as separate areas in cut and fill.

Gradient limits may also be specified to indicate slope or plan areas of particular interest. For example, the area to be covered by topsoil or the area of vertical wall to receive a protective coating can be determined.

Slope areas may be calculated along the ground or along the proposed surface.

Minor option 048 stores the information produced by minor options 046 and 047 in a 10 dimensional area string.

**Method of computation****Figure 4 - 54 Cut and fill area**

The total slope area is calculated by taking the mean of the slope lengths at adjacent cross sections and multiplying the resultant length by the distance between the cross sections. The areas for cut and fill can be calculated in a similar way by distinguishing between the mean slope lengths in cut and the mean slope lengths in fill.

Area calculations for minor option 047 are based upon sections normal to a reference string. Small differences will occur between the results obtained by this minor option and minor option 041 as this minor option does not apply curvature corrections.

The accuracy of the calculated area increases as the number of cross sections used increases. Generally, minor option 173 in SECTION should be used to generate the cross sections, as this minor option generates a cross section for each point on the reference string.

**Area string data**

The following table shows the data stored in each dimension of an area string. This information can be used when annotating a drawing with areas. See major option DRAW for further details.

Dimension	Area string data
1	Easting (X)
2	Northing (Y)
3	Elevation (Z)
4	Chainage (C)
5	Area between the two previous sections
6	Accumulated area
7	Cut area between the two previous sections
8	Accumulated cut area
9	Fill area between the two previous sections
10	Accumulated fill area

**Input**

**Graphics**

AREA minor options	Section based areas	Section based areas
Define system parameters	Reference string label	Slope/plan areas (T)
Define linear units	First subsidiary string	Section set 1
Define string masking	Second subsidiary string	Section set 2
Within boundary string	Area string label	Maximum gradient
Between two strings	Start chainage /X coord	Minimum gradient
2 intersecting boundaries	Start point no. /Y coord	
Slope between two strings	End chainage /X coord	
Triangulation area	End point no. /Y coord	
Section based area		
End AREA		

IGAREAT.DAT, ARE002,ARE011,ARE012

**Linemode**

**Minor option 046**

- \* Field 1      Reference string label
- \* Field 2      First subsidiary string label
- \* Field 3      Second subsidiary string label
- Field 5 & 6    SPRD for start
- Field 8 & 9    SPRD for end

Minor option 047

- Field 1 SLOP or PLAN (default SLOP)
- Field 2 Section set 1 prefix character.
- \* Field 3 Section set 2 prefix character.  
This section set is the prominent section set, ie, the section set which has sectioned through the subsidiary strings coded in minor option 046. The prominent section set determines the surface along which the slope areas are measured.
- Field 7 Minimum gradient limit  
This determines the gradient above which areas are calculated.
- Field 10 Maximum gradient limit  
This determines the gradient below which areas are calculated.  
Minimum and maximum gradient limits should be used to avoid unwanted areas being included in the calculation. For example, vertical structures such as kerb edges and retaining walls can be excluded by specifying gradient limits.

◇ This option must be preceded by minor option 046.

Minor option 048

- \* Field 3 Label of the area string to be created.  
For details of the data held in an area string, see 'Area string data'.

Example 1

The following example gives the total slope area between strings SL01 and SL03 based on the sections with prefix character 'D'. The results would then be stored in a string ASTR in the model AREA MODEL.

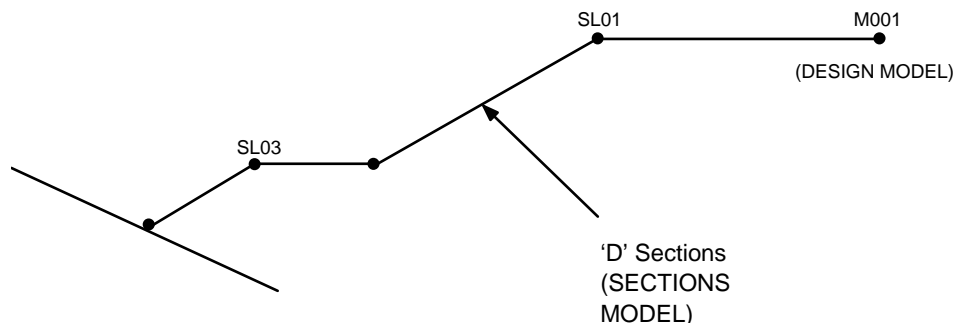


Figure 4 - 55 Total slope area

```
AREA, , SECTIONS MODEL, DESIGN DESIGN MODEL, SECTIONS MODEL
AREA, AREA MODEL
046, M001, SL01, SL03
```



```
047,3=D  
048,3=ASTR  
999
```

Example 2

The following example gives cut and fill slope areas between strings IR01 and IL01 based on the sections with prefix character 'D'. The results would then be stored in a string ASTR in the model AREA MODEL.

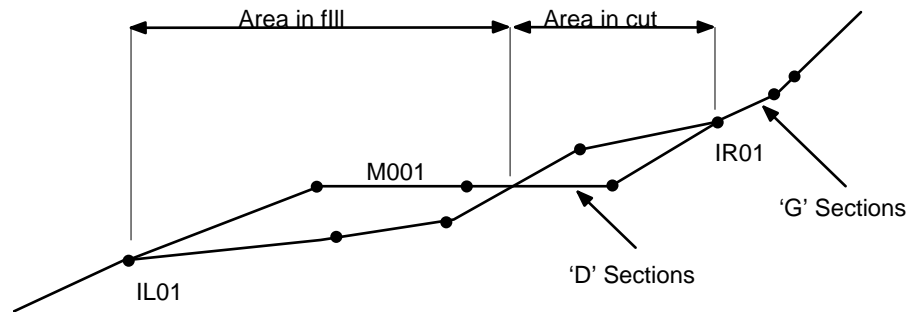


Figure 4 - 56 Cut and fill slope areas

```
AREA,SECTIONS MODEL,DESIGN MODEL  
AREA,AREA MODEL  
046,M001,IR01,IL01  
047,,G,D  
048,3=ASTR  
999
```

# Chapter 5 Survey

## Survey

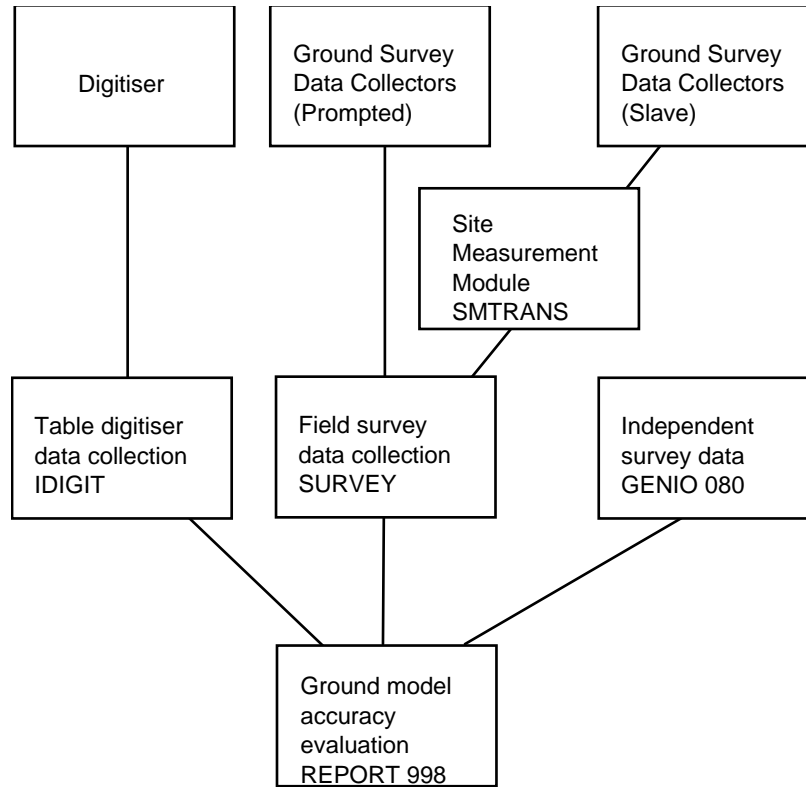
### Introduction

The survey options IDIGIT (Interactive Digitising) and SURVEY provide facilities for the creation of models containing both level information defining the ground surface and detail information defining features such as carriageways, hedgelines, buildings etc. The detail strings may simply record the plan information or additionally record the level information and contribute to the ground surface.

The level models are a digital representation of a complex surface and with MOSS they are defined by a combination of feature lines for the definition of irregular or acute ground features such as the tops and bottoms of embankments, existing and proposed carriageways, channels, centre lines, kerbs, verge details etc and contour or general lines for the recording of ground curvature. Each of these features or lines is defined by a series of coordinates and is stored in MOSS as strings of two or three dimensional points.

The MOSS philosophy assumes that a linear surface exists between adjacent strings and between points along a string. It is therefore apparent that the overall accuracy of the model is governed by the spacing of the points along a string and the spacing between adjacent strings. It is the users responsibility to ensure the model content is sufficiently dense to ensure that linear interpolation between the stored information will produce results within the desired tolerance.

There are four major options together with ancillary programs supporting the survey facilities and their relationship is illustrated in the following diagram:-



**Figure 5 - 1 Survey facilities and their relationships**

Major option IDIGIT allows the interactive recording of existing plans in digital format using table digitisers. String information recorded in locally digitised coordinates is transformed into the required real coordinate system. A major advantage of IDIGIT is that many of the MOSS interactive facilities are available whilst generating the model. The model and the drawing are created simultaneously and any errors may be visually identified and corrected. An existing model may be displayed as a backcloth during the process.

Before IDIGIT was developed and integrated within MOSS, major option DIGIT was supplied to process data which was prepared external to MOSS. Major option DIGIT is still supplied and is designed to process data produced on instruments connected to stereoscopic plotting machines commonly used for the interpretation of aerial surveys, or table digitisers which are used for the recording of existing plans.

Major option SURVEY is a complete ground level and detail surveying system which permits the recording of field information by all the modern methods of surveying. Field information is recorded by a series of observations which depict the detail as strings of data. The observations are processed and stored directly as strings of coordinate data which, when plotted, will automatically produce a plan of the survey. The surveying technique requires the surveyor to record the information in a methodical manner but offers the advantage of completely automating the process of converting field records to plotted plans.

The field observations may be recorded directly in MOSS format but are more likely to be recorded by data collectors. Early models simply store the measurements with associated code information, and these have to be pre-processed to produce MOSS records.

Current devices can provide full prompting and can output preformatted MOSS minor options automatically. The Site Measurement Module has been developed for just such an independent device, accommodating all survey instruments. This system provides both full prompting for traversing and detail survey observations, and additionally permits automated setting out.

Ground information may be prepared by either of the two techniques permitted by major options IDIGIT and SURVEY. Models may consist of data prepared by one of the described methods or a combination of the methods. An example of such a situation is where it is necessary to extend or replace a section of model originally prepared by aerial survey. This may be most conveniently achieved by ground surveying and illustrates the flexibility of the string concept. In such a situation care must be taken that the string and point density produce similar model accuracy.

Major option GENIO permits the input of survey information in string form which is prepared independently of the MOSS system. This feature is advantageous when ground survey information is obtained by contract and the coordinate information is produced by the contractors own system. The real coordinate data is entered using minor option 080 which allows the definition of a convenient input format, and it is fully described in Chapter 14 External programs.

Once models have been prepared and stored it is desirable to check their accuracy against their original specification. Major option REPORT provides a technique for assessing accuracies of the model information prepared by either of the described methods.

The majority of uses of ground models require sectional information in the form of either long or cross-sections and the tests are based on sectional principles. The aim of the test procedure is to select several test areas to provide a sufficient sample of the model and within each area to survey several long sections recording precisely the ground profile. For each test section the equivalent model section is determined and the two sections are compared to determine the mean difference and range of confidence interval. These results are examined for the sections within each test area and for the total sample to assess the overall quality of the model.

The surveying and testing options make considerable use of the MOSS plotting facilities to verify the collected information.

# Major option IDIGIT

The major option IDIGIT (Interactive Digitising) creates models of two and three dimensional strings from data recorded using a table digitiser. It may be invoked from LINEMODE or interactive graphics mode.

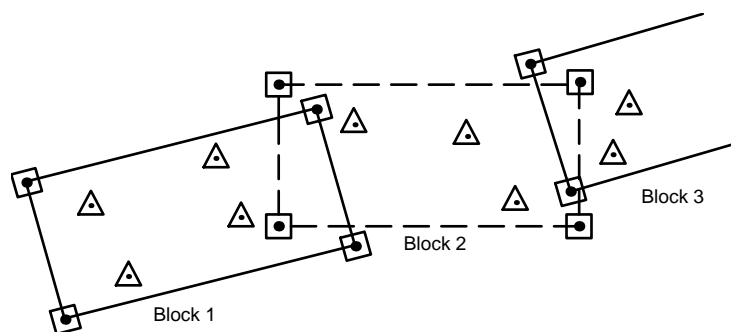
## Digitiser equipment

Digitisers of different manufacture use different operating methods and the IDIGIT option allows for the more popular variants. Installations may have more than one digitiser and up to 10 configurations are catered for. You may choose which digitiser to use. Your system administrator will be able to clarify what is available to you.

## Data organisation

The area of the model is considered as a series of blocks of data consisting of string information. The major option processes these blocks of information, recorded in local or machine coordinates and transposes the coordinates into a real world coordinate system. During the process it will be possible to perform an optimisation function to remove excessive points from strings subject to a specified tolerance in the horizontal plane.

The blocks of data are a convenient means of identifying areas in which strings are to be recorded. They may be a complete plan or an area of interest within a plan. The blocks bear no relationship to the way in which the final model is stored within MOSS. The blocks are quadrilateral in shape and may overlap but duplication of string content within blocks should be avoided.



**Figure 5 - 2 Example of data organisation**

The information required by IDIGIT for each block of data is:-

1. The machine coordinates of the Block Corners.
2. Machine and true coordinates of several points in the model to be digitised. These allow transformation of the coordinates from local or

machine coordinates to true coordinates. These are the so-called TRANSFORMATION CONTROL POINTS.

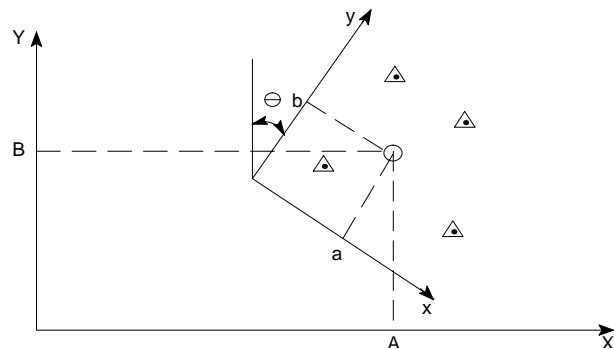
3. String Data in machine coordinates

There is no limit to the number of blocks that can be processed by the major option and existing models can be extended by further use of the major option.

**Block transformation**

The transformation of the block information from machine (or local) coordinates is based on the method of least squares. Between 3 and 5 transformation control points are recorded in both machine or table coordinates and real world coordinates. The transformation is based on the centroid of these points so that any errors in the control points themselves are uniformly distributed.

- △ Control points
- Centroid of control points



**Figure 5 - 3 Example of block transformation**

The transformation equations are:-

$$X = K_1 (x - a) - K_2 (y - b) + A$$

$$Y = K_1 (y - b) + K_2 (x - a) + B$$

- where:
- A and B are the X and Y coordinates of the centroid of the control points in real world coordinates.
  - a and b are the x and y coordinates of the centroid of the control points in table coordinates.
  - $K_1$  is the cosine of the transformation angle \* the scale factor.
  - $K_2$  is the sine of the transformation angle \* the scale factor.

The adequacy of the transformation is assessed by comparing the errors of the transformed points in the direction of the new axes with the standard errors for the transformation. Any points having an error greater than twice the standard error are suspect and indicated by a warning message. If any points have an error 3 times greater than the standard error the transformation is considered invalid. The suspect point coordinates should be corrected or rejected and the complete block of data re-run.

In addition to assessing the relative magnitude of the errors compared to the standard error, the absolute magnitude of the errors should be considered for their acceptability regarding the accuracy required for the transformed information. The coordinate errors are compared with a tolerance which is specified with the initial block input (default value of 1.0 metres) and if it is exceeded the transformation is considered invalid. The transformation information or tolerance must be reassessed before re-running the block data.

### String content

The detail within each block is recorded as string information. All angular features are recorded as 3D strings and the infilling curvature is recorded by contours (2D) string or further 3D strings where the contours are sparse. The frequency of strings and model points recorded should be at a sufficient density to permit the sectional information to be extracted to within the desired level accuracy.

Feature strings may also be recorded to depict surface detail such as fences, hedges, buildings etc. These strings may be identified by unique character references eg F, H, B to enable ease of identification, they may be stored as 2D strings (contours) with a null level (-999.0), or as 3D strings containing the appropriate level at each point. It is recommended that you ensure no string label reference characters have dual meaning.

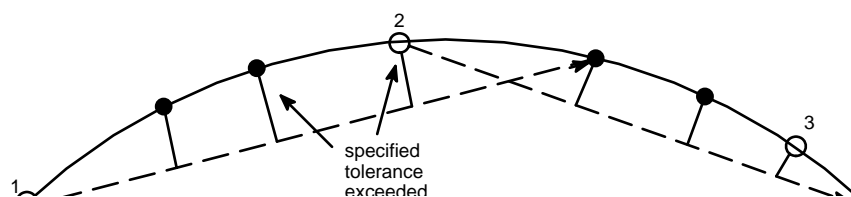
### String detail

Within each block a string may start or finish at any point providing it is not more than 10 model units outside the boundary of the block for which the data is being recorded. Continuity between blocks should be provided in the form of a short overlap between the end of one string (eg in Block 1) and the start of another string (eg Block 2).

If a string is digitised more than 10 model units outside a block boundary a warning is given when the string is being sent to the model. At this point the user has the opportunity to modify the points in error or proceed to send them to the model.

### String optimisation

It is preferable to store the digitised string information in the model but if the volume of data is considered too large it is possible to reduce the volume of information by optimising the points to within a specified tolerance.



**Figure 5 - 4 Example of string optimisation**

The optimisation process takes each point on a string and joins it in the horizontal plane to successive points on the string. The tolerance is exceeded if distance from any intervening point to this line is greater than specified. The next optimum point on the string is the point preceding that at which the tolerance was exceeded. The process is repeated from this point. Points which lie within this tolerance (ie points between the "optimum" points) are discarded.

It must be stressed that optimisation detracts from the accuracy of the model but will reduce the time required to process the model in other major options. Therefore the degree of optimisation must be a compromise between accuracy, processing time and storage capacity.

### String identification

All strings are identified by a four character label unique to the model in which the strings are stored. This label may be fully or partially specified by the user. Where it is necessary to relabel any string the standard convention will be followed.

Where string labels are to be partially specified, only the initial letter should be used to take advantage of the processing efficiency.

There are certain string naming conventions that are recommended for use throughout the system which, if used, minimise the amount of information to be specified to Major option DRAW for the production of drawings with standard detail interpretation.

The conventions apply to the first character of the string label as follows:-

D	Ditch
F	Fence
G	Geometry string
H	Hedge
I	Interface
L	Level points (Spot levels)
M	Master alignment
P	Point strings. The second and third characters may be used for further definition with the exception of PSSA which is used for survey stations, eg
	PGU            Gullies
	PEP            Electricity pole
	PTP            Telegraph pole
V	Verge

### Major option IDIGIT

The option operates within IGMODE, where menus guide and prompt you through the facilities available.



## Access to major option IDIGIT

IGENLT.DAT, GEN001

Survey Options
IDIGIT
EDIT
COPY
REPORT

## Model for IDIGIT

IDIGIT.DAT, DIG011

Model for IDIGIT
Model to be digitised

**Model to be digitised** is the model to contain digitised information.

- ◇ *The model IDIGIT TRANSFORMATION MODEL TRF is also used to contain the digitiser to model coordinate transformation and the block corner point coordinates.*

## Review and modify tolerances

IDIGIT.DAT, DIG001

IDIGIT Tolerances
Allowed contour step inter
Contour level conv factor
Allowed 3D step
3D level conversion factor
Allowed transform error
Chord-to-arc tolerance

The **Allowed contour step interval** is user defined. A warning will be issued if the current contour level varies from the last by more than this “step interval”.

Some digitisers will only allow integer values to be given. In this case you should redefine the **Contour level conversion factor** so that when the integer level is multiplied by the CLCF the resultant level value is in the current range. For example, if the typed level value is 1234, and the CLCF is 0.001, the resultant stored value for the contour will be 1.234.

The **Allowed 3D step** is user defined. A warning will be issued if the current level varies from the last by more than this value when digitising successive 3D string points.

As with contours, some digitisers will only allow integer values to be assigned. Therefore the **3D level conversion factor** should be reset to convert these integer values to the designed numerical range.

The **Transformation tolerance** defines the adequacy of the transformation from the table coordinate system to the real coordinate system. It will vary according to the scale of the plan being digitised; for example if the scale of the drawing is 1:500 the acceptable transformation tolerance will be typically 1.0 ie 0.002 at plotted scale.

The **Chord-to-arc tolerance** (described in ‘String Optimisation’) defaults to 0.25 model units.

◇ *Default values are given for all tolerances. Immediate selection of proceed will skip to the environment menu.*

## Review and modify environment defaults

IDIGIT.DAT, DIG002

<b>IDIGIT Environment</b>
Level input method (T)
Option selection method (T)
Ring bell at each point (T)
Draw pip at each point (T)
Digitiser type
Digitiser mode (T)

**Level input method** may be toggled between the terminal keyboard or the digitiser puck for entry of 3D string levels.

**Option selection method** may be toggled between the terminal keyboard or the graphics cursor for the entry of editing functions.

**Ring bell at each point** may be toggled to provide audible confirmation or not.

**Draw pip at each point** may be toggled to provide visual confirmation or not.

Each **Digitiser type** supported requires specific protocols. Digitiser type must be typed from the keyboard.

**Digitiser mode** a toggle allowing selection of point, track or stream mode.

**Point mode** (Default) allows you to digitise individual points.

**Track mode** is similar to Point mode but displays the position of the puck on the tablet.

**Stream mode** stores a series of points as a string is traced with the puck. The frequency of points is dependant on the digitiser configuration.

Both Track and Stream modes may be dependant on the functionality of the digitiser. Your systems administrator will be able to clarify what functions are available to you.

◇ *Default values are provided for all environment defaults. Immediate selection of proceed will skip to the transformation points menu.*

## Select transformation points

IDIGIT.DAT, DIG003

IDIGIT Transformation pts	
1 Digitiser	X
	Y
Model	X
	Y
2 Digitiser	X
	Y
Model	X
	Y
3 Digitiser	X
	Y
Model	X
	Y
4 Digitiser	X
	Y
Model	X
	Y
5 Digitiser	X
	Y
Model	X
	Y

At least 3 transformation points are needed to derive the transformation between the digitiser's 'table' coordinate system and the real world coordinate system. The operator is prompted to digitise each point and then define the associated real world coordinates. The prompts are automatic for the first three points but further transformation points (up to 5) may be chosen at your discretion.

Each transformation point is represented on the scrolling menu by four menu boxes - two for the digitised or table coordinate, and two for the real world or true coordinate. To modify the true coordinate only, pick one of the bottom two boxes. If one of the top two boxes is picked then both table and true points are prompted for. Keying RETURN for the true coordinate boxes will leave the values unchanged.

On selection of 'PROCEED' the transformation is calculated and the results displayed. A prompt will be given to either 'PROCEED', (if the transformation is acceptable) or any one or more of the transformation points may be redigitised.

- ◇ *The transformation is stored in a special model IDIGIT TRANSFORMATION MODEL TRF so that it need not be respecified if you exit and re-enter IDIGIT. It is important, however, that you do not move the map or drawing being digitised between uses of major option IDIGIT if you wish to use the stored transformation.*
- ◇ *At this stage there is still nothing visible on the graphics display.*
- ◇ *A second proceed will result in the display of the block corner points menu.*

## Select block corner points

IDIGIT.DAT, DIG004

IDIGIT Block corner pts
Block BL - X=
Y=
Block TL - X=
Y=
Block TR - X=
Y=
Block BR - X=
Y=

Four points need to be digitised to define the extent of the area to be digitised, and should be digitised clockwise beginning with the bottom left. This provides details of the acceptance polygon outside of which any digitising will be notified. It also serves to scale the drawing area in to the graphics display area.

- ◇ *The block corner points are stored in a special model IDIGIT TRANSFORMATION MODEL TRF so that they need not be respecified if you exit and re-enter IDIGIT. It is important, however, that you do not move the map or drawing being digitised between uses of major option IDIGIT if you wish to use the stored points.*

## Select drawing parameters

IDIGIT.DAT, DIG005

<b>IDIGIT Drawing details</b>
Grid selected (T)
Grid interval
Frame selected (T)
Drawing scale
Sheet length
Sheet width
Bottom left X coordinate
Bottom left Y coordinate
Sheet rotation

A major advantage of IDIGIT is the simultaneous generation of the digitised model and a drawing. Consequently the scale of the generated drawing is requested so that a complete Draw Picture File (DPF) may be developed.

- ◇ *By selecting PROCEED all the data so far submitted will be processed and the graphics display area will show the drawing with the transformation points and block corner coordinates displayed as symbols. The drawing will appear on the screen at the same orientation as that of the plan on the digitiser.*

## Digitise strings

Before you digitise any strings, you are given the option of using the displayed DPF or of erasing the elements within it. If any of the digitising area lies outside the extents of the DPF, a warning is given.

IDIGIT.DAT, DIG006, DIG007

IDIGIT Option details	Digitise a 2D string
Digitise a 2D string	Label
Digitise a 3D string	Level
Edit current string	
Locate puck position	
Terminate sheet	

◇ On completion of each string, operation of the 'end of string' button on the puck will cause display the Digitise options menu. This allows you to edit the current string, start a new string or terminate the sheet.

IDIGIT.DAT, DIG006, DIG008

IDIGIT Option details	Digitise a 3D string
Digitise a 2D string	Label
Digitise a 3D string	Level
Edit current string	
Locate puck position	
Terminate sheet	

Either 2D contour strings or 3D strings may be digitised and you will be prompted for the string label and 2D level (if applicable).

At this stage all keyboard input is expected via the terminal keypad unless puck input of 3D levels has been requested.

When '**Digitise a 3D string**' is selected the prompt 'Enter level' is displayed and control is passed to the keyboard (or digitiser puck, depending on user environment) at this stage two methods are available.

1. To apply one level to all points on a string, enter a level and return. IDIGIT will use this level for all points on that string. You only have to digitise the XY positions eg this is useful for creating 3D strings with null levels.
2. To enter a level for each point on a string, hit return. you are prompted to digitise a point and enter a level for that point. Digitising will then continue in the fashion point/level/point/level ...etc. until the string is terminated.

Confusion can arise because the message area does not explain the difference between the two options, so if you enter a level for point 1 no further levels can be input for the current string.

For each string, on completion of the keyboard input you are prompted to start digitising points. While digitising, the digitiser puck may be used to invoke various features such as, delete previous point, assign null level, etc. These features vary according to the digitiser and the digitiser puck itself. Systems notes will be available to describe individual configurations.

◇ *On completion of each string, operation of the 'end of string' button on the puck will display the Digitise options menu. This allows you to edit the current string, start a new string or terminate the sheet.*

## Edit current string

IDIGIT.DAT, DIG006, DIG009

DIGIT Option details	Edit current string
Digitise a 2D string	Delete current string
Digitise a 3D string	Delete a point
<b>Edit current string</b>	Move a point
Locate puck position	Insert point(s)
Terminate sheet	Continue string
	Close string

As each string point is digitised its position is echoed on the graphics display. When the string is complete, but before it is committed to the model, you may modify it. At this intermediate stage between digitising and storing within the model the operator may choose to:-



**Delete current string:** no string will be stored and the string will be erased from the picture.

**Delete a point:** control will be passed to the graphics cursor to identify the appropriate point. PROCEED will confirm the deletion and prompt for another point to be deleted. QUIT will return to the main menu.

**Move a point:** the graphics cursor is used to identify the appropriate point and then control is passed to the digitiser puck to identify the new point. If the string is 3D, a level must also be given.

**Insert point(s):** the graphics cursor is used to identify the appropriate point in the string. Control is then passed to the digitiser to identify the new points which will be added after the chosen point.

**Continue a string:** the digitiser puck is used to add more points onto the end of the string.

**Close string:** a new point is automatically created at the end of the string which is coincident with the first point, forming a closed loop.

## Locate puck position

IDIGIT.DAT, DIG006, DIG010

DIGIT Option details	Locate puck position
Digitise a 2D string	Digitiser X
Digitise a 3D string	Y
Edit current string	Model X
Locate puck position	Y
Terminate sheet	

**Puck location:** Display a cross on the screen showing the position of the puck on the digitiser.

When the current string is satisfactory it may be committed to the model, and it will also be added to the picture in the line style and colour current at the time.

At any time during string modification, you may quit the current function either by selecting the QUIT box in the menu, or by depressing the terminator button (usually No. 4) on the digitiser puck.

## Terminate sheet

IDIGIT.DAT, DIG006

<b>IDIGIT Option details</b>
<b>Digitise a 2D string</b>
<b>Digitise a 3D string</b>
<b>Edit current string</b>
<b>Locate puck position</b>
<b>Terminate sheet</b>

During the digitising process, the strings are stored in a “temporary” model. This model is independent of the model to which the strings will ultimately be directed. You are required to “terminate the sheet” in order to store these strings permanently. The string labels of the “temporary” model will be compared with the strings in the receiving model and, if relabelling is necessary, both the strings in the temporary model and the drawing are updated.

# Major option SURVEY

## Introduction

The facilities within SURVEY allow direct creation of high quality digital maps. They can also record detailed engineering surveys with complementary digital surface models.

The SURVEY option is fully supported by data recording using total stations and data collectors.

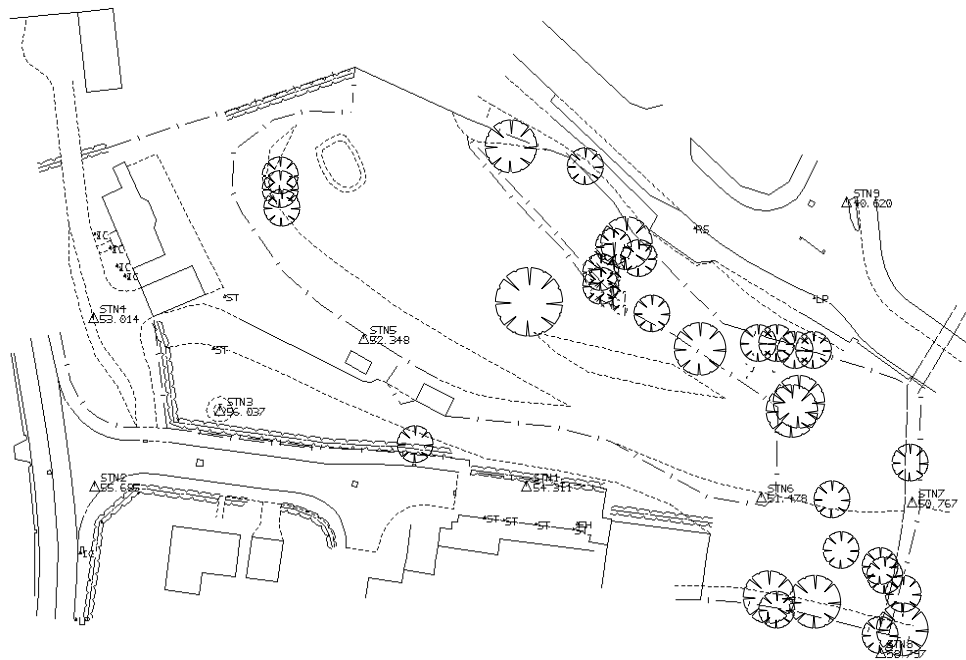
Each surveyor will have a different method of working in the field and this has been recognised during the design of the MOSS SURVEY option. A high level of flexibility has been built into the data recording facilities and this should enable the system to be adaptable to a surveyor's individual method of working.

Many surveying processes are now automated by the equipment used in the field and computers in the office which provide plotting and interactive screen editing. This frees the surveyor to concentrate on collecting the required information accurately and as efficiently as possible.

The facilities in MOSS for editing models and enhancing drawings using a graphics screen allow the surveyor to complete the survey in the office. These facilities mean that the surveyor can simplify the way he records features in the field. The complexity of the survey will dictate the balance between field stringing and the requirement of interactive editing.

The production of a survey using MOSS will have the following stages:-

- Specification of the survey
- Planning the field work:
  - string recording / use of interactive editing.
  - determine stations before detail or
  - record station and detail observations together.
- Collect data in the field
- Process data using major option SURVEY
- Produce computer plots to check the survey
- Interactive editing of model where necessary
- Interactive enhancement of drawings



**Figure 5 - 5 Drawing of complete survey**

The drawing above shows a completed survey. The text was added to the drawing using the interactive enhancing facilities in MOSS. Most of the examples shown in this chapter are part of this survey.

The main facilities in major option SURVEY are summarised below:-

- Various observation styles; geometric, 3 stadia tacheometry, chain and offset, real coordinates
- Calculation of stations by traverse, intersecting rays, resectioning
- Ability to mix observations for generating stations and detail
- Alternative methods for coding string labels
- Recording of curved strings with simplified curve recording and application of circular and spline curves in strings
- Minimisation of field booking by allowing:
  - recall of a previous observation
  - adjustment of an observation
  - generation of points and strings from other features in the survey
  - closing of strings
  - recording of circular and rectangular feature as objects
- Detailed but easy to follow printed output which shows a complete analysis of the processed survey. Any errors in the data are clearly identified
- String relabelling. This simplifies the coding of labels and allows a survey to be created from several sets of data

- Correction factors
- Storage of all points in the survey in a single string for later use with interactive editing.

## Principles of creating surveys using MOSS

The surveyor must understand the principles described in this section before collecting survey data in the field. He will then be able to plan the overall approach required for the survey and also determine the best approach for some of the more specific problems encountered in the ground surveying.

### Types of string

The surveyor's objective is to record the features on the ground so they can be stored in a ground model and reproduced on drawings. The features must be stored in the model in a format which allows the model to be used for generating contours and extracting sections. When the survey is drawn out the features must be easily identifiable as road channels, fences, lamp posts etc.

This is achieved by using different types of strings to represent different features. Hence there are:

Strings to represent linear features such as channels, fences, hedges. Points are stored in the string in the correct order to define the feature. Hence, the points are linked together and if a section is taken through the model then a point will be interpolated on a link between string points to calculate the intersection of a string and the section line.

Strings to represent features which are unique points on the ground such as lamp posts and trees. Typically the lamp posts would be recorded in one string and the trees in another. Here there is no continuity between adjacent points in the string. These strings will not have lines joining the points when they are drawn out and no attempt is made to interpolate between adjacent points when sections are being calculated.

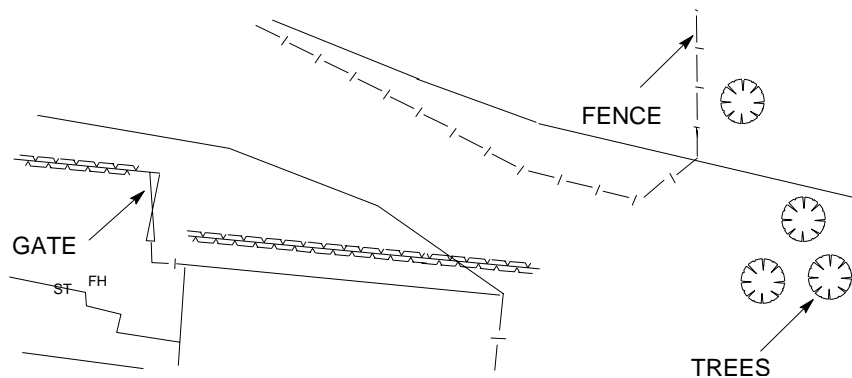
Strings which store features such as gates, buildings, manholes. This type of string is a combination of the two earlier types and it allows features to be grouped together in a string giving linear continuity between the points defining a feature but no continuity between the individual features.

Strings which define surface level in open areas. These strings are really the same as those which define linear features on the ground except that the feature is imaginary. Levels can be interpolated from links between adjacent points. These strings are unlikely to be shown on the final drawings (unless shown as spot levels) and surface level is more likely to be depicted by contours generated from the survey.

Hence it is important that the surveyor is aware of the different types of strings and that he 'thinks in strings' which relate to linear features on the finished drawing - the process of recording is 'drawing' in the field. It is important to stress that the method of recording a point is the same

irrespective of the type of string. In fact, besides being recorded in the same way the different types of string are generally stored in the model in the same way. Hence it is the label given to the string which indicates the 'type' and how the string is to be used.

Figure 5 - 6 highlights the following strings:- a string to define a fence, a string to store gates and a string to store trees.



**Figure 5 - 6 Drawing showing key features**

### String labels

The key to getting the most out of the MOSS survey facilities is the use of the string labels. The surveyor has a great deal of scope for specifying string labels but there are certain conventions built into MOSS which are based on the first character of the string label. These conventions must be understood by the surveyor. The first letter of a string can govern the results produced by MOSS at two different stages:-

When drawings are being produced the first letter of the label indicates what type of feature the string defines eg hedge (H), verge (V). The string is then drawn in an appropriate line style (if detail interpretation is requested).

When the model is being analysed to generate contours or sections the first letter of the label dictates whether there is continuity between adjacent points and hence if points can be interpolated on string links. The only strings which are treated as containing points which are unrelated and having no continuity between them are strings which have labels beginning with the letter P. Hence if you are recording unique points eg lamp posts, you must use a P string with a label such as PLP1. If you are creating a string which has continuity between its points you must not give it a label which starts with P.

When the survey is being drawn the first letter of the label invokes an appropriate line style for some common features. The following are available by default:-

B	Building
C	Channels
D	Ditch
F	Fence

- H Hedge
- L Level strings
- P Point strings as described above. The second and third characters are printed out on the drawing at the side of the points in the string eg PLP1, for lamp posts, PTP1 for telegraph poles.
- V Verges

The line styles used for these labels are shown in Figure 5 - 7 .

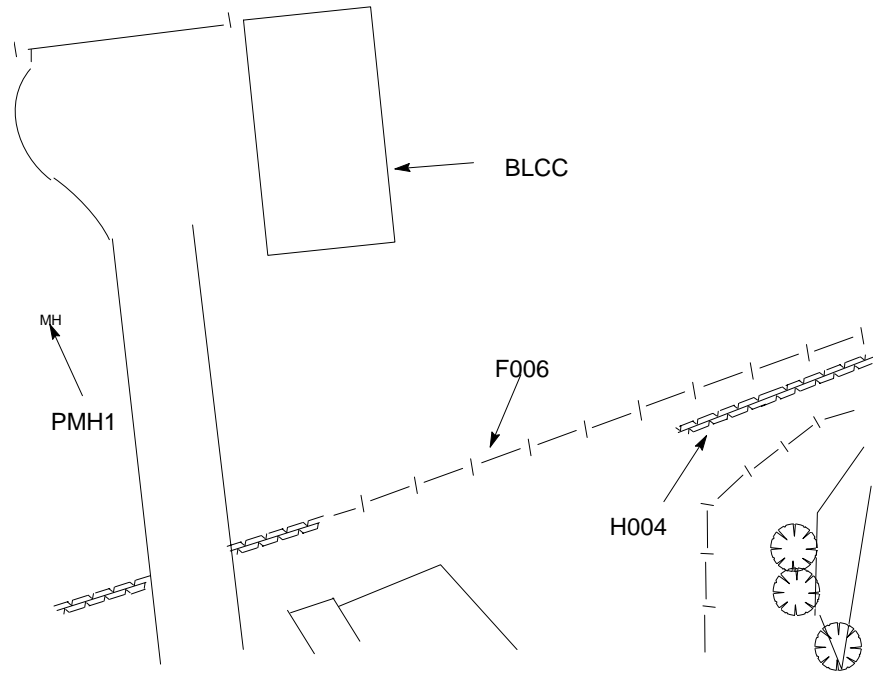
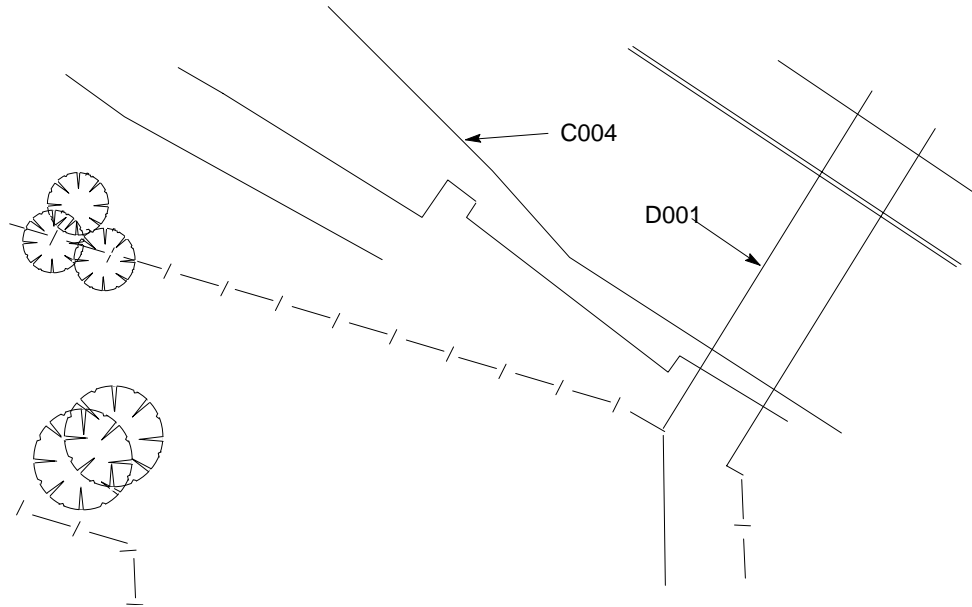


Figure 5 - 7 Drawing showing typical feature string labels



**Figure 5 - 8 Drawing showing typical feature string labels**

The line styles here are defaults and the surveyor can override these and define his own styles for each feature. The example shown here simply illustrates the principle of invoking different line styles for different features by coding the string labels according to a predefined convention. The very simple convention shown here will be replaced by the surveyor's own convention. A more comprehensive labelling convention is supplied with the MOSS system and is invoked using the SURVDRAW macro described in an earlier section. Even this will probably serve as no more than a base to be modified and extended as the surveyor adapts the use of MOSS to conform to a labelling system defined in a survey specification or to conform to digital mapping standards. The result is likely to be a detailed convention which could be difficult to keep track of while recording observations in the field. If the surveyor does not wish to book the detailed labels in the field then they can be introduced later by the interactive editing facilities.

We recommend that strings beginning with M are not generated in ground surveys. M-strings are master alignment strings created by the alignment options.

### Recording strings

The basic concept of MOSS is that features are defined by strings which themselves are collections of points. In a ground survey each observation will be reduced and the corresponding point calculated (x, y, z). The surveyor must specify which string the point is stored within.

The facilities for coding feature labels offer complete flexibility to enable MOSS to be accommodated within the surveyor's method of working. At one extreme the surveyor can generate the final layout of the strings by detailed booking in the field. Processing the data then produces a perfect survey which needs no further editing. At the other extreme the surveyor

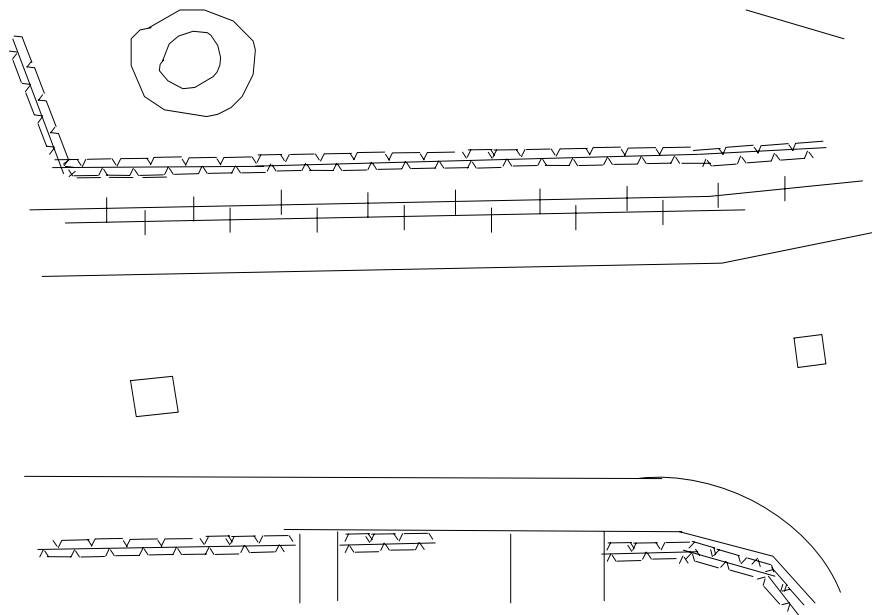


can simply record all the points in a single string in the field and then form the feature strings by editing in the office.

The facilities for recording observations and editing surveys allow the surveyor to balance field work and office work so he can achieve the most efficient compromise for each survey. For methods available see the section on coding string labels in the field.

### **Interactive editing of the survey**

When the field data has been processed the survey will need editing and enhancing to produce the final ground model and survey drawings. The editing will join together short strings which are part of the same feature and give meaningful labels to the strings so the correct symbols and lines are invoked for the survey drawings. The enhancements will include adding text and symbols. Figure 5 - 9 and Figure 5 - 10 show part of a survey as it appeared after processing the field data and in its final form after editing and enhancing.



**Figure 5 - 9 Drawing without enhancement**

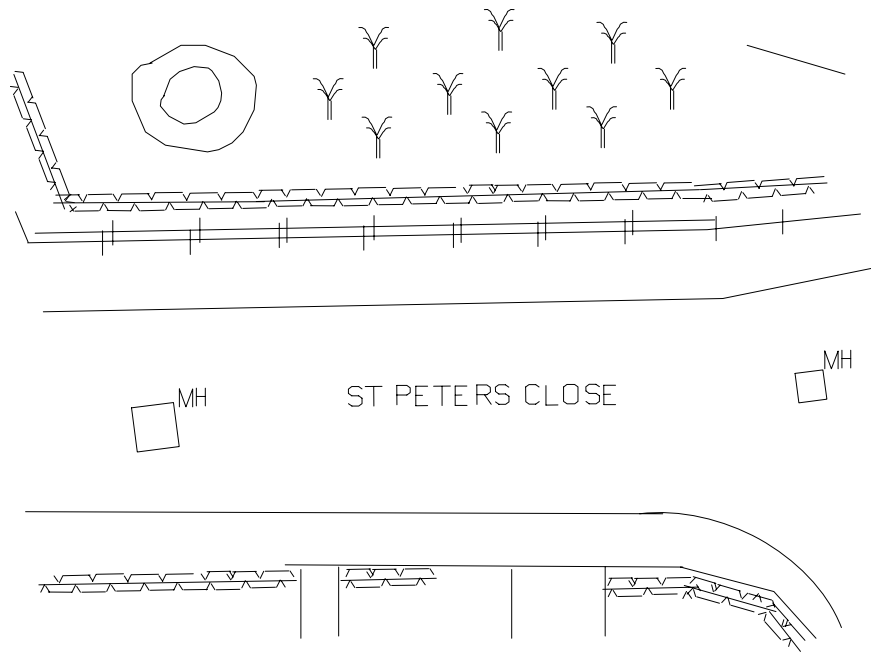


Figure 5 - 10 Drawing with enhancement

### Mixing observation styles in a survey

Observations can be accepted from a wide range of instruments and equipment eg geometric, 3 stadia tacheometry, chain and offset. Different observation styles can be mixed within a set of survey data. For example a surveyor may wish to set up temporary stations during a geometric survey to use as a base line for recording a building using chain and offset observations.

### Mixing station observations and detail observations

When the data is processed all observations which are used for calculating new stations are reduced before any observations which record detail. This allows the surveyor to set his instrument up on a station of unknown coordinates, record observations to other stations to fix it and record detail from the station.

Although this approach can be used for traversing it is more likely to be used when stations are being determined as fly stations or by resectioning or intersecting rays. In practice a traverse is most likely to be calculated and checked before any detail is picked up.

### Building up a survey from several sets of data

For larger surveys where it takes several days or weeks to gather the observations the data will be generated in batches - typically a batch may be one day's work. The batches will be processed individually but each will add strings to the same survey model. There is no limit to the size of the survey model but each batch of data has a limit of 3000 observation records.

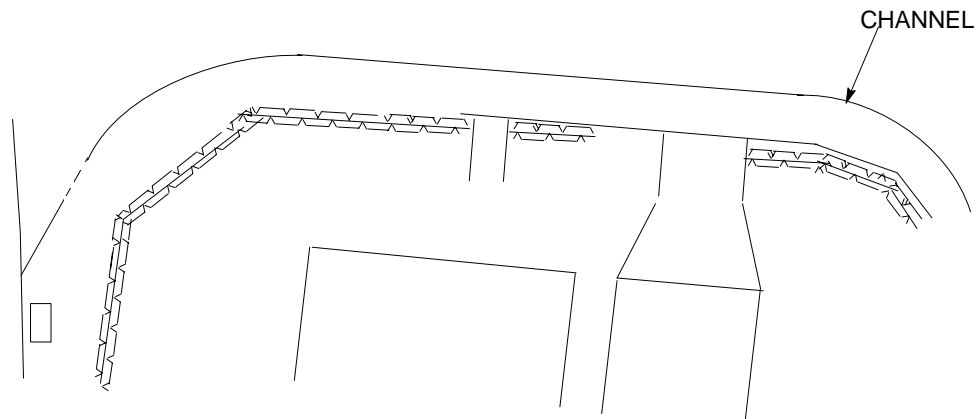
If a string is to be added to a model and there is already a string in the model with the same label then the new string is given a new label. Hence the system ensures that strings in a model always have unique labels. See section on the principles of string relabelling.

### Curve in strings

When strings represent linear features they must contain sufficient points to define the feature accurately. Hence points need to be closer together on a curved part of a string than on a straight section. To achieve the required density of points on curved sections the surveyor records location points and indicates that they lie on a curve - the extra points are calculated and stored when the data is stored.

Straights and curves can be mixed freely within a string. Minor option 201 indicates the point lies on a straight and 202 is used for points which are on a curve.

Circular curves or spline curves can be generated. Figure 5 - 11 shows a channel string containing straight and curved sections. See section on recording curves.

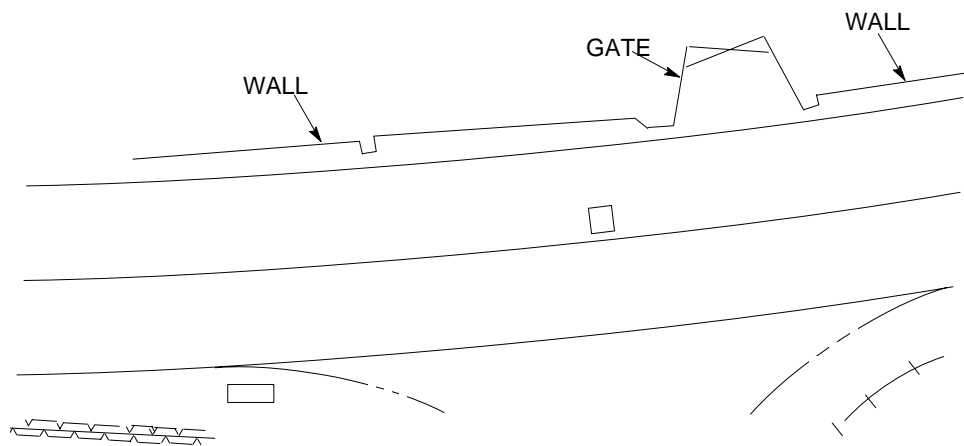


**Figure 5 - 11 Drawing showing channel**

**Creating points and strings from features already recorded**

Several facilities are available which reduce the amount of information to be recorded.

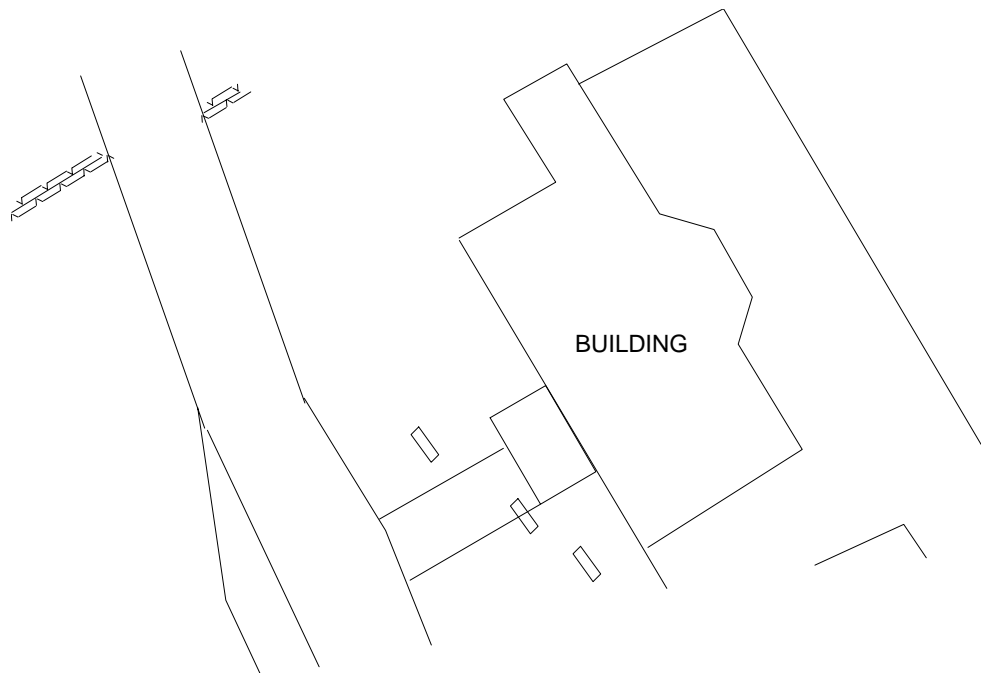
Figure 5 - 12 shows that the two points which define the gate also need to be in the string defining the wall. There will be two records in the data for each point but the observed measurements are recorded on the first one only. On the second record an indicator is coded to recall the measurements from the first record.



**Figure 5 - 12 Drawing showing strings with common points**

See section on recalling observations. Observations can be recalled and then adjusted. See later section describing adjusting observations.

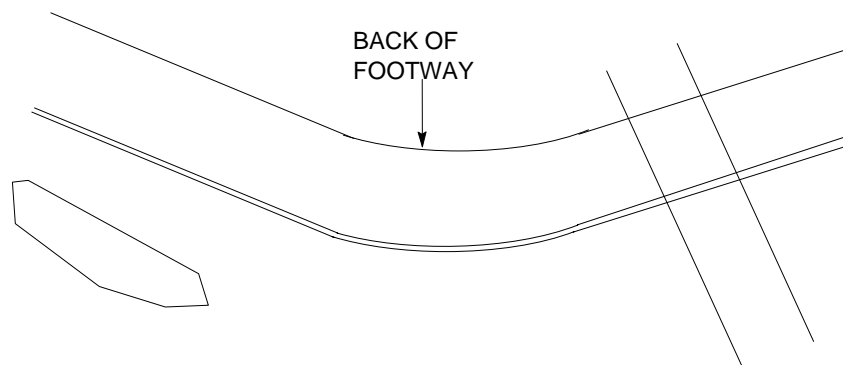
Figure 5 - 13 shows a building in a survey. The string defining the building contains eleven points. Only the first two were located by geometric observations. The next eight points were recorded by taping around the building. The last point was introduced by requesting that the string be closed (ie first point is repeated as the last point).



**Figure 5 - 13 Drawing showing a building in a survey**

See sections on taping and closing of features.

If a feature is a constant offset from a string already recorded in the survey data then the surveyor can generate the new feature by specifying the offset - he does not need to observe points on the string. In Figure 5 - 14 the road channel was recorded by observations to points on the string but the string defining the back of the footway was recorded simply by coding the offset from the channel.



**Figure 5 - 14 Drawing showing constant offset from survey string**

See section on creating strings parallel to other strings.

Individual points can be generated by specifying offsets from string links and this is described in a later section.

**Methods for defining rectangular and circular features**

A string which defines a rectangle requires five points. When the surveyor is recording these features in the field he can record a rectangle by three points or two points and a width. The extra points are calculated and stored when the data is processed.

Similarly there are simple ways for defining circular features in the field (eg centre and radius) which allow extra points to be calculated later. The surveyor has a choice how the information is stored in the model and the recording and storage of rectangular and circular objects is described in a later section. These facilities are designed for recording features such as manholes and not features like islands or roundabouts.

**Correction factors**

Observations can be modified by applying correction factors for:-

Height above sea level

Curvature of the earth and refraction

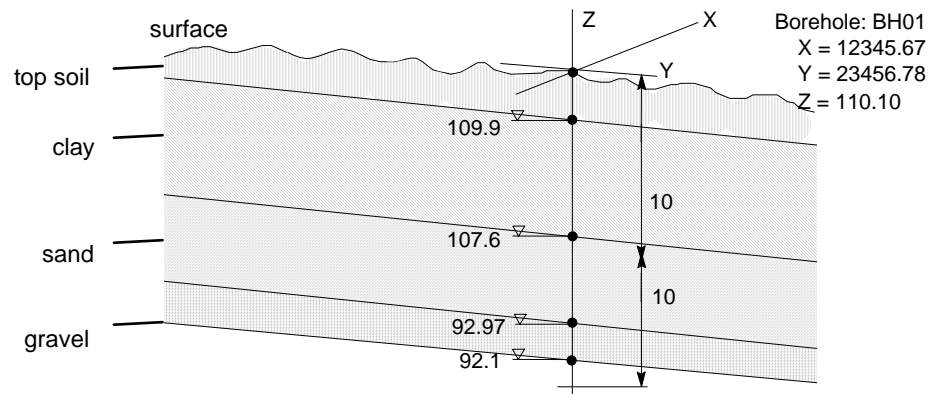
Scale factor

See section on applying correction factors.

**Borehole logging**

Borehole log information can be input to MOSS using major option SURVEY. Each borehole position is treated as though it were a survey station with defined coordinates and collar or ground level. Each geological horizon is then represented as a string with a point at each borehole position where the horizon was found.

- ◇ *The resulting MOSS model will contain a PSSA string giving borehole positions and collar level and a series of geological horizon strings. These strings can then be copied or triangulated into their own surface models for further analysis as required.*
- ◇ *Borehole information cannot be mixed with other information in the same survey.*



**Figure 5 - 15 Example of a borehole**

The coding of the above example will require three minor options 180, 200 and 201. The number of 201 options used will depend on the number of strata changes for each borehole.

For each borehole a new set of options will be required.

To define the borehole and its position

```
SURVEY, GROUND SURVEY
180, 3=BH01, , 12345.67, 23456.78, 110.10
```

To define current borehole and observation method

```
200, BH01, , BORE
```

The substrata may be coded either, using minor option 201 field 3 and 6 to determine the type and depth of strata

```
201, 3=SOIL, 6=0.2
201, 3=CLAY, 6=2.5
201, 3=SAND, 6=11.13
201, 3=GRAV, 6=18.0
```

or using minor option 201 field 1 = LEV, and fields 3 and 7 to determine the type and level of strata. These methods can be mixed as required.

201, LEV, 3=SOIL, 7=109.9  
 201, LEV, 3=CLAY, 7=107.6  
 201, LEV, 3=SAND, 7=98.97  
 201, LEV, 3=GRAV, 7=92.1

## How MOSS processes the survey data

### General format of data

A set of survey data will always contain details of the instrument set ups (ie set up station, reference station, reference angle) and details of the observations themselves (ie measurement components, label of the string which will store the point, indicators to invoke special features such as taping or string closing). In some sets of data the surveyor may need to add stations, specify correction factors, specify instrument constants. A series of minor options is available for recording the information and they are summarised below:-

- 000            Insert a comment line  
Used for including comments in the data.
- 017            Amend system parameters  
Changes some system defaults eg label of stations string, format of angular input/output.
- 180            Add, amend or delete stations from a stations string  
Adds known stations to a model (also modify, delete stations).
- 189            Survey constants record  
Specifies values for survey parameters eg default type for curve fitting, chord to arc tolerance.
- 190            Theodolite and Traversing constants record  
Specifies instrument constants eg vertical angle increases/decreases to zenith, traverse adjustment constants.
- 200            Instrument set up record  
Contains details of an instrument set up.
- 201            Observation point on straight  
Records all details for the observation of a point (on a straight).
- 202            Observation point on curve  
Identical to 201 but indicates point is on a curve.
- 203            Offset strings  
Creates a string parallel to another string in the survey.



Hence a simple data set could be:-

```

SURVEY GROUND MODEL,STATIONS MODEL
  ADD STATIONS STN9 AND STN6 TO STATIONS STRING
180,,,STN9,,1215.155,1142.775,40.620
180,,,STN6,,1202.082,1098.418,51.478
  SET UP AT STN9 AND SIGHT TO STN6
  INSTRUMENT READINGS ARE HORIZ ANGLE,HORIZ DISTANCE,
AND LEVEL DIF.
200,STN9,STN6,HDL,2124026
  START RECORDING OBSERVATIONS FOR STRING CC01
201,,,CC01,981035,4.494,-0.060
202,,SPLI,,1622048,9.588,0.070
202,,,,,1670828,13.366,0.130
202,,,,,1644213,17.052,0.190
201,,,,,1545915,29.042,0.330
  GENERATE STRING VC01 FROM CC01
203,CC01,,VC01,0.175,7=-2.1
  START OBSERVATIONS FOR NEW STRING
201,,,C,3093711,55.554,0.050
201,,,,,3060533,47.288,0.050
201,,,,,3043355,47.705,0.240
201,,,,,2874537,30.026,0.370
201,,,,,2831049,25.463,0.290
999
FINISH

```

### Stages in data processing

The processing of the data is split into several distinct phases and a brief insight into this will help the surveyor's overall understanding of the survey facilities.

The following stages are involved in the processing:-

- Read the data, check the data for errors, and store all the data in the program.
- Calculate the coordinates of any stations which are being created from observations in the data. Output analysis details for traversing, intersecting rays and resectioning. Output a summary of the stations used in the survey.
- Reduce all the observations. Check for error conditions.
- Generate the string labels to be used for storing the points. This itself is a two stage process. Firstly the input data is considered in isolation and full 4 character labels are generated from the partial labels specified by the surveyor. All labels generated are unique. Secondly the set of new string labels is compared with the labels already in the model. Any conflicts are resolved to ensure all labels in the final model are unique. (Labels of existing strings in the model are never changed).

- Group the points together in strings and store them in a temporary area within the program. Extra points generated by curve fitting, closing and the expansion of objects are introduced at this stage.
- Output details of the observations. A table is produced showing the input data, the calculated coordinates, string labels and any error messages generated.
- Calculate points which are derived from other strings recorded in the survey data ie creating strings parallel to other strings.
- Provided no errors have been generated the new strings are added to the survey model. If there are any errors the existing model remains unchanged.

### General format of output

The printed output produced by the data is shown below. The 'observations details' table gives information for each observation record in the data. Each record shows the data supplied by the surveyor, the reduced coordinates of the point and the label of the string where the point will be stored.

```

SURVEY  GROUND MODEL          STATIONS MODEL
SUMMARY OF STATION DETAILS
-----
-NAME-  -X-  -Y-  -Z-  -STATUS-
STN6    1202.082  1098.418  51.478  CREATED BY 180 OPTION
STN9    1215.155  1142.775  40.620  CREATED BY 180 OPTION
OBSERVATION DETAILS
-----

                ADD STATIONS STN9 AND STN6 TO STATIONS STRING
180                STN9 1215.155  1142.775  40.620
180                STN6 1202.082  1098.418  51.478
                SET UP AT STN9 ANS SIGHT TO STN6
                INSTRUMENT READINGS ARE HORIZ ANGLE, HORIZ DISTANCE, AND LEVEL DIFFERENCE
200STN9STNGHDL  2124026
                START RECORDING OBSERVATIONS FOR STRING CC01
201                CC01 981035  4.494  -0.060  *  1219.604  1143.406  40.560  CC01
202  SPLI  1622048  9.588  0.070  *  1220.503  1134.817  40.690
                W606 SPLINE CURVE FITTING APPLIED.
202                1670828  13.366  0.130  *  1221.658  1131.097  40.750
202                1644213  17.052  0.190  *  1224.077  1128.243  40.810
201                1545915  29.042  0.330  *  1234.309  1120.945  40.950

```

```

GENERATE STRING VC01 FROM CC01
203CC01      VC01  0.175      -2.1
START OBSERVATIONS FOR STRING CC01
201          C   3093711  55.554      0.050      *          1164.157  1164.809  40.670
C000
201          3060533  47.288      0.050      *          1170.674  1158.824  40.670
201          3043355  47.705      0.240      *          1169.866  1157.764  40.860
201          2874537  30.026      0.370      *          1185.139  1143.565  40.990
201          2831049  25.463      0.290      *          1189.729  1141.410  40.910
999
CALCULATION OF OFFSET STRINGS
-----
-NEW STRING-  -REFERENCE STRING-  -HORIZONTAL OFFSET-  -VERTICAL OFFSET-
                VC01          CC01  -2.100   0.175

```

## Instrument set up

### Instrument details

MOSS uses the following default values:-

Vertical angle datum is 0.0

Vertical angle increases to zenith

Constant  $K^1$  is 100.0      Used for calculating distance from  $f \cdot K^1 + K^2$

Constant  $K^2$  is 0.0      |(f is stadia readings/slope distance)

If an instrument with different characteristics is being used then the appropriate values should be changed using minor option 190. This option needs coding only once within a set of data except in the event of the instrument being replaced.

Full details of coding data for the 190 option are given later in this chapter.

The example below shows the 190 option being used for an instrument where the vertical angle has a datum of 90 and decreases towards zenith.

```

190          DECR 090000
200STNASTN2HDVA  3210000
201          CIR  13151127.  134.387  0850000 *  1062.535  1035.183  111.757  CIR1
201          3281337.   148.060  0861500 *  1085.236  1008.778  109.704
201          3423549.   158.545  0872945 *  1098.304   971.254  106.934

```

### Instrument set up at a station

When an instrument is set up over a station the following information must be provided:-

- name of the instrument station
- name of the reference station
- the horizontal angle datum
- the style of the observation

The first three items provide the necessary information to allow the observed points to be calculated relative to the coordinate base defined by the stations for the survey.

MOSS can accept data from all common methods of surveying. Different instruments produce data in different formats and the style of the observation needs to be specified. This defines the measurement components on the observation records. The styles are summarised below:-

Geometric observations - produced by self reducing tacheometers (s.r.t)  
or s.r.t plus electronic distance measurement device (e.d.m)  
or theodolite plus (e.d.m)  
or total station

An observation comprises 3 components:-

horizontal angle: distance: level.

The style to be given indicates how the distance and level components have been measured, where:-

HD = Horizontal distance  
SD = Slope distance  
VA = Vertical angle  
VT = Vertical tangent  
LD = Level difference

Hence typical styles are:- HDVA, SDVA, HDLD, VAHD etc

Chain and offset - CHOF  
3 stadia tacheometry - STAD  
3 stadia with height factor - STAK  
Real coordinates - REAL

All the information required to define an instrument set up is coded on minor option 200.

The example below shows the 200 record for an instrument set up at station STN2, sighting to station STN1. The horizontal angle datum is 2794215. The instrument records horizontal distance and level difference.

```
200STN2STN1 2794215
201 C A 183701 20.215 1.755 1 * 1096.868 1080.029 57.440 C005
201 PLP1 172600 20.202 1.855 2 * 1097.283 1079.982 57.540 PLP1
```

### Setting the height of collimation

If the standard target height is the same as the instrument height then the height of collimation does not have to be defined since the two heights cancel each other.

If the surveyor does need to set the height of collimation he must define it on each 200 option. The most common method will be to give the height of the instrument in field 7 as shown below

```
200 , STN1 , STN2 , HDLD , 000000 , , , 1.5
```

Alternatively collimation can be determined by an observation to the reference station:-

```
180   STN1    940    980   -999.0
180   STN2   1030   1010.0  110.0

200STN1STN2HDLDD  000000  1.0   1.5                      W579 COLLIMATION LEVEL CALCULATED
                                     FROM THE REFERENCE STATION
201   C  3151127.  134.387  5.0   1.5                      *  100.500  1099.998  114.000  C000
201                        3281337.  148.060  3.75                *  1034.759  1093.765  112.750
```

In this example collimation is calculated from the level component in field 6 (1.0) and the value in field 7 (1.5) which is the height of the target at the reference station. Note that when electronic data recording is used to record measurements, care should be taken that the level component is only recorded when collimation is to be based on the reference station.

MOSS will calculate collimation from the reference station when the level component of the observation is supplied. Hence the surveyor should take care when automatic data recording is in use that a full observation is not recorded on a setup record when collimation is to be determined from the instrument station.

See section on changing target heights.

### Check observations to verify the instrument set up

The surveyor will probably wish to include a check to ensure that the set up details are correct. This is done by taking a check observation onto a third station. This can be included as the first observation record. It is simply an ordinary observation with the name of the station observed in field 3 and the indicator CHE in field 1 as shown.

The reduced coordinates from the observation are compared with the stored coordinates for STN4. If there is a discrepancy a warning is generated:-

```
200STN2STN1HDLDD  2794215  *1099.887  1125.34  53.014  1095.488  1124.93
201CHE             STN4 1892653  25.340 -2.671  1099.887  1125.339 -2.571  53.014  1099.887  1125.33
STN4                STN4 1792889  340.112533891  53.014  1099.887  1125.339
These check observations for STN4 station can be included as the first observation
on any W579 DISCREPANCY IN
data - they do not have to follow a 200 option.
```

### Applying correction factors

- The actual observation may be modified by applying correction factors to allow for:
- Height above sea level correction
  - Curvature of the earth and refraction correction
  - Scale factor correction

### Sea level correction

If the sea level correction is invoked (by coding a level in field 9 of a 200 option) then the reduction of the measured distance (slope or horizontal) is calculated as follows:-

Reduced distance = measured distance\*radius/(radius + height of instrument above sea level)

The radius is taken as  $6.370 \times 10^6$ m but may be changed on option 189

### Curvature correction

A combined correction for curvature and refraction may be applied to each measurement (field 8 on minor option 200). The correction is added to the vertical angle as follows:-

$$A_c = + \frac{d_m}{r} \left( \frac{1}{2} - k \right)$$

where

$A_c$  = adjustment

$d_m$  = measured distance (corrected sea level distance, either horizontal or slope)

$r$  = radius ( $6.370 \times 10^6$ m)

$k$  = coefficient of refraction (0.071)

The coefficient of refraction and the earth's radius may be modified using minor option 189.

### Scale factor correction

The scale factor is applied to horizontal distance and adjusts field measured distances to the equivalent distance on the base plane of the projection applying to the map.

The value of the scale factor lies typically in the range 1.0004 to 0.9996.

The adjustment is made as follows:-

$$D = d * F$$

where

$D$  = adjusted distance

$d$  = non modified distance

$F$  = is the scale factor to be applied.

The scale factor  $F$  is defined in field 10 on minor option 200, and if given the height above sea level must also be given in order to apply sea level correction.

- ◇ *If the scale factor is applied then the sea level correction is automatically applied to the distance before applying the above formula.*
- ◇ *The sea level and curvature corrections may be applied by the instrument when using total station equipment and data recorders. In this case there is no need to invoke the corrections when the data is processed. Care should be taken to ensure the corrections are not introduced twice.*

## Survey stations

### The Stations string

The stations in a survey are stored in a special string known as the stations string. It has a default label of PSSA. It can be stored in the same model as the survey or in a different model. A report showing the contents of a stations string is shown below.

```

992PSSA
LABEL  SUBREF  CONTENTS  NO.PTS  X -MIN  Y-MIN  X-MAX  Y -MAX  RECORD LC
PSSA   SSTA    7704      9       1099   1075   1226   1143   109

POINT  ----X----  ----Y-----  -HEIGHT-  --LABEL--
  1     1000.000  1100.000    55.685    STN2
  2     1166.195  1100.000    54.311    STN1
  3     1220.298  1075.015    58.797    STN8
  4     1225.110  1097.614    50.767    STN7
  5     1166.195  1100.000    51.478    STN6
  6     1220.298  1075.015    52.347    STN5
  7     1225.121  1097.614    53.014    STN4
  8     1166.195  1100.000    40.620    STN9
  9     1220.298  1075.015    56.037    STN3
  
```

Using the default label will meet most needs but the surveyor can use a different label if he wishes, or even have more than one stations string for every survey. For these cases the label of the station string must be given on an 017 option:-

```

017,,,PSSB
200,STN1,STN2,HDL,0000000
  
```

If more than one station string is used they must be used in separate batches of data- they cannot both be used within the same batch.

### Modifying the stations string using minor option 180

Minor option 180 is used to add new stations to the stations string and to modify or delete stations already in the string. Stations which are calculated from observations in the survey are automatically added to the stations string.

To add a station the name and coordinates are coded on a 180 option:-

```

180,,,STNA,,1000.0,1200.0,85.0
  
```

To delete a station the following is needed:-

```

180,,,STNA,-1.0
  
```

If a station is to be modified new values are given for the coordinates to be changed. If an independent level survey of the stations has been done the levels will need adding to the stations.

```

180,,,STNB,,,,110.0
180,,,STNC,,,,115.0
  
```

A full description of coding data for option 180 is given later in this chapter.

### Levels of stations

It has been common practice to determine the levels of stations by independent levelling. However total station instruments can measure level

differences accurately and new levels to be calculated when the stations are located.

Hence levels will be calculated for stations which are determined by traverse, intersecting rays, and resectioning. The level error is distributed in proportion to the square root of the distances of the observations.

This feature should only be used with care. If it is used with simple tacheometric observations the accuracy of the adjusted levels will be uncertain and this is not recommended. Total Station equipment should produce more reliable results. It is the user's responsibility to establish the standard required for level information and if there is any uncertainty in the accuracy then the stations must be levelled.

### **Priority order for calculating stations**

Stations can be determined by four methods: traverse, intersecting rays, resectioning, or from fly observations. When these methods are used within a set of data the stations are calculated in the following order:-

Traversing stations

Intersecting ray stations

Resection stations

Fly Stations

This would allow, for example, a station to be located by intersecting rays using observations from stations in the traverse. Similarly a fly station could be created by an observation from a station which was being located by resectioning.

However no method for calculating stations can use reference stations which themselves have been determined by a method lower in the priority order. Hence observations for a resection calculation cannot be taken onto a reference station which has been fixed as a fly station. Note that this priority order only applies when stations are being calculated by different methods in the same set of data. The method of fixing a station is not retained when the stations are added to the stations string.



## Calculating stations by traverse

Traversing allows the coordinates to be calculated for a series of stations. The total angular and distance errors in the series of observations are determined and distributed. MOSS allows open traverses and closed traverses with several methods of end fixity.

The calculations will generate coordinates based on the error adjustments and it is the surveyor's responsibility to assess the accuracy of the calculated coordinates.

Only a single traverse can be processed within any one run of the SURVEY option.

The surveyor can select the method of adjustment to be used from the Bowditch (compass method), Unaltered Bearings (Crandall's method), or Bird's method.

Detail observations can be mixed with the traverse observations if this is required. Mean values are calculated for angles and distances if multiple backsights and foresights are recorded.

### Observations taken at each instrument set up

The basic principle of traversing is that a series of observations taken in a logical sequence from stations of unknown coordinates can be processed together with observations to known stations at the start and end of the traverse. The coordinates of all the unknown stations can be calculated.

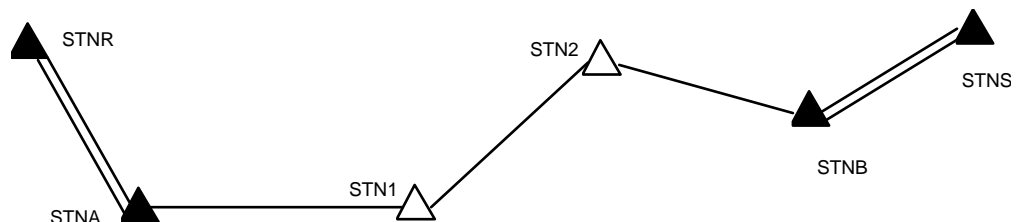


Figure 5 - 16 Example traverse

For the traverse shown above the known stations are STNR, STNA, STNB and STNS.

The coordinates for stations STN1 and STN2 are to be calculated. The sequences of instrument set ups will be to set up first at STNA, then STN1, STN2 and finally STNB.

At each station a backsight observation to the previous station and a foresight observation to the next station are needed. Hence a pair of these observations will be recorded at each station where the instrument is set up. These observations enable the consumed angle between the previous station and the next station to be determined at each station. Distances between stations are also calculated. The value used for the distance between two stations is the mean of the backsight and the foresight values.

More than one pair of backsight and foresight observations can be taken at a station. This enables a mean value to be calculated for the consumed angle.

The set up record and the observations at stations STNA and STN1 are shown below.

```
200, STNA, , HDLD
201, TRAV, , STNR, 0000000
201, TRAV, , STN1, 1350000, 100.0, 0.5
200, STN1
201, TRAV, , STNA, 0000000, 100.0, -0.5
201, TRAV, , STN2, 1500000, 115.470, 0.4
      |
      | etc
```

Traverse observations are indicated by TRAV in field 1.

- ◇ *The reference station and the horizontal angle datum are not coded on the 200 option when traverse observations are being recorded. If this information is needed to process details observations it is taken from the last backsight observation at a station. The last fore sight observation supplies the information if backsights are to a reference bearing and not to a station. For traverses the height of collimation cannot be determined from the reference station.*

### End conditions for traverses

Where possible MOSS will make adjustments for angular closure and coordinate closure but this will only be possible for some type of end fixity. In some cases only an angular or a coordinate adjustment can be made. The different cases of end fixity are now described.

Traverses which do not end with an observation onto a known station or a known bearing are known as **open traverses**:-

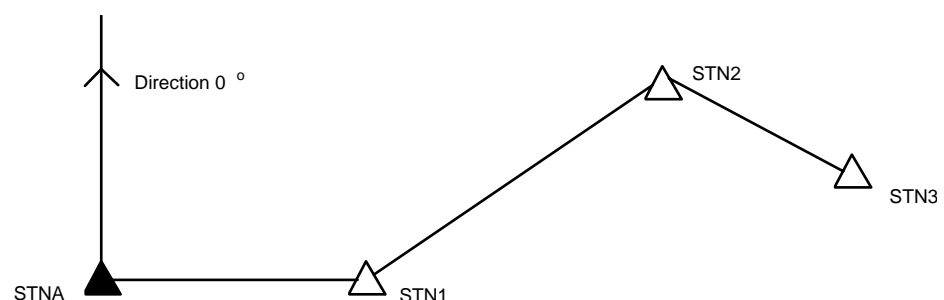


Figure 5 - 17 Example open traverse

In Figure 5 - 17 STNA is a known station. STN1, STN2 and STN3 will be calculated. The backsight at STNA is to a known bearing in this case.

```
200, STNA, , HDLD
201, TRAV, , , 0000000, 8=0000000
201, TRAV, , STN1, 900000, 100.0, 0.0
200, STN1
```

| etc

Alternatively the backsight could be onto another known station:-

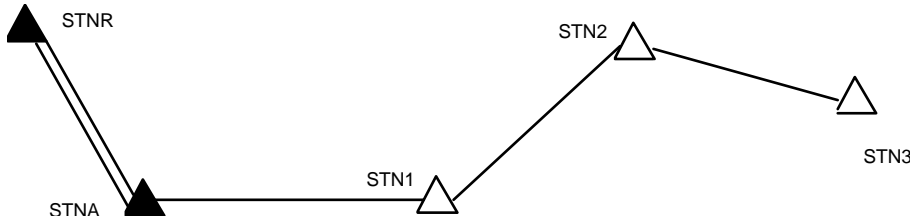


Figure 5 - 18 Second example open traverse

Traverses which end with an observation to a known bearing, or to a known station are **closed traverses**. In Figure 5 - 19 stations STNR, STNA and STNB are known. Stations STN1 and STN2 will be calculated. This case allows only a coordinate check to be done.

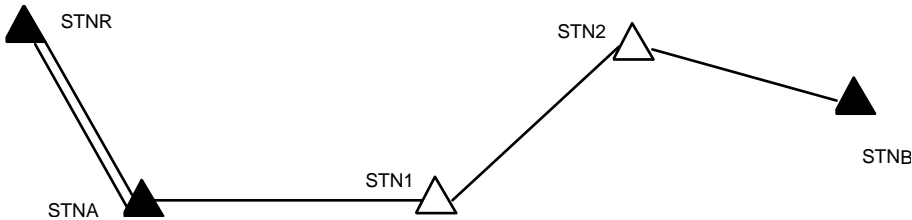


Figure 5 - 19 Example closed traverse

Figure 5 - 20 shows the case where the traverse ends with an observation to a known bearing. Stations STN1, STN2 and STN3 will be calculated. Only an angular check can be done.

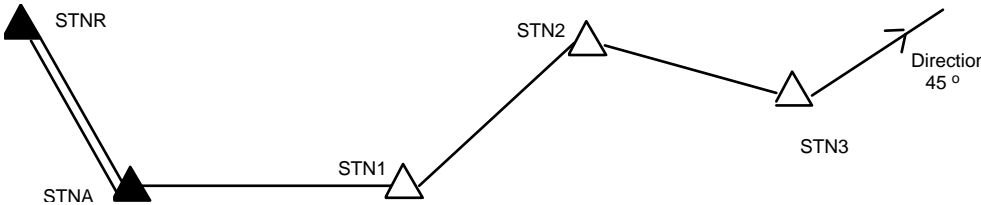
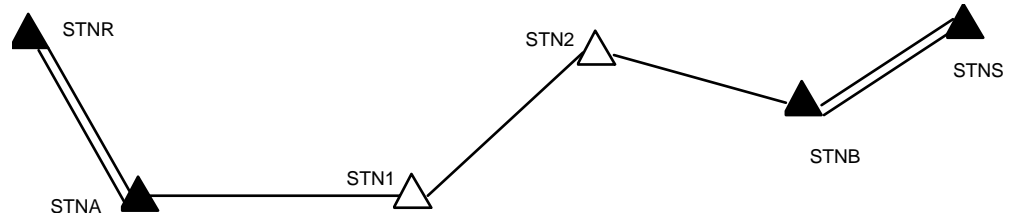


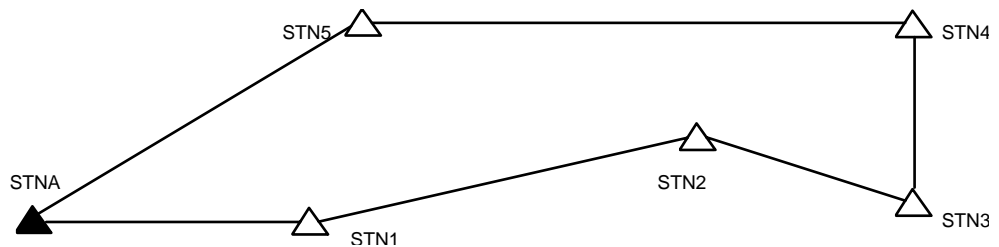
Figure 5 - 20 Example traverse ending with observation to a known bearing

Figure 5 - 21 shows a traverse which ends with an observation from a known station (STNB) to another known station (STNS). This time both coordinate and an angular check can be done. (The foresight from STNB could be to an azimuth bearing).



**Figure 5 - 21 Example traverse ending with observation from known station to another known station**

Figure 5 - 22 shows the full adjustment of a local survey. STNA is used as the local origin and will be assigned coordinates. The reference direction is from STNA to STN1.



**Figure 5 - 22 Example full adjustment of a local survey**

The example later in this section shows the full adjustment of a local traverse.

### Methods for adjusting traverses

The methods of traverse adjustment which may be requested are as follows but it is stressed it is the user's responsibility to select the method that is most suitable for his work, the accuracy of the measurements and the characteristics of the survey instruments.

### Bowditch Rule or compass rule

The Bowditch Rule is a widely used method of adjustment and its popularity is probably because it is simple manual technique. It was originally produced for the adjustment of compass traverses where the bearings of the line are completely independent, whereas in modern traversing the bearings are computed from independent angles. The technique assumes that the error produced in the direction of a line will be equal to that at right angles to it. These assumptions are not acceptable for modern Total Station traversing.

### Unaltered bearings rule or Crandall's Method

The unaltered bearings rule adjusts the traverse without altering the initially adjusted bearings. The method is described in Jameson's textbook 'Advanced Surveying' and the method assumes that the probable linear

errors are proportional to the square root of the distance. Basically it is a least squares method in which the angles have infinite weight.

Any angular closing error is initially equally distributed between the stations and the partial easting and northing coordinate errors determined.

Prior to the development of Total Stations equipment, angular measurements were usually considered more accurate than linear measurements and this method is very 'practical' in that it retains the angles at the expense of the linear measurements. This is often considered advantageous when using traverse stations for setting out.

In certain situations, knowing the relative accuracy of the angular and linear measurements, this assumption may be acceptable but in order to maintain the bearings, relatively large adjustments are necessary to the internal stations and the solution produces greater sums of squares values than the Bowditch Rule and many of the other adjustment techniques.

### **Bird's Method**

This the least squares technique developed for the adjustment of traverses carried out with Total Station equipment when the instrument has a significant zero error. The method essentially requires the initial distribution of the angular closing error equally among the stations. This is followed by the least squares solution to the three traverse condition equations.

Each leg of the traverse is weighted by an expression combining its angular and linear error. The expression requires an estimate of the mean square error (m.s.e) of an observed angle and m.s.e.'s for the zero error, Z, and linear error, F, in the distance measurement.

The type of adjustment required is coded on option 190:-

190 , , BIRD

If no method is selected then the Bowditch method will be used by default. Full details of coding data for option 190 are given in a later section.

### **Closing Errors and Adjustment Constants**

MOSS uses the following default values:-

Permissible linear closing error	- 1 in 10000
Z constant for Bird's method	- 0.005
F constant for Bird's method	- 5.0 (parts per million)

If the surveyor wishes to change any of these values they can be changed using minor option 190. See later in this chapter for full details.

### **Traverse Example**

Figure 5 - 23 shows the full adjustment of a local survey. One of the stations is taken as the origin (STN2). The direction between STN2 and STN1 is used as an azimuth bearing. Angular and distance adjustments are applied.

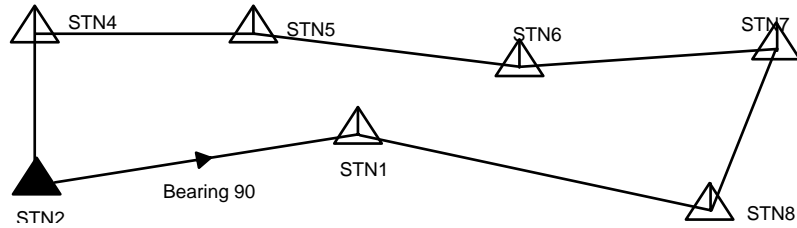


Figure 5 - 23 Example traverse

Input

```

SURVEY ST PETERS CLOSE STATIONS
190,, BIRD
    STATION 2 HAS ASSUMED CO-ORDINATES
    THE TRAVERSE ORIGIN
180,3=STN2,5=1100,1100,55.685
    SET UP ON STATION 2 BACKSIGHT TO AZIMUTH BEARING
    ( TO STN1 )
    FORESIGHT TO STN1
200,STN2,, HDLD
201,TRAV,4=2794215,8=900000
201,TRAV,3=STN1,2794215,66.195,-1.374
200,STN1,, HDLD
201,TRAV,3=STN2,3341711,66.195,1.374
201,TRAV,3=STN8,1790427,59.593,4.486
200,STN8,, HDLD
201,TRAV,3=STN1,3570318,59.593,-4.486
201,TRAV,3=STN7,741854,23.107,-8.030
200,STN7,, HDLD
201,TRAV,3=STN8,72816,23.107,8.030
201,TRAV,3=STN6,872519,23.053,0.711
200,STN6,, HDLD
201,TRAV,3=STN7,1733310,23.053,-0.711
201,TRAV,3=STN5,125316,65.336,0.870
200,STN5,, HDLD
201,TRAV,3=STN6,310816,65.336,-0.870
201,TRAV,3=STN4,1940952,41.457,0.666
200,STN4,, HDLD
201,TRAV,3=STN5,2901326,41.457,-0.666
201,TRAV,3=STN2,153627,25.340,2.671
200,STN2,, HDLD
201,TRAV,3=STN4,0000000,25.340,-2.671
201,TRAV,4=901522,8=900000
999
    
```

Output

SURVEY ST PETERS CLOSE STATIONS

CALCULATION OF TRAVERSE

-----

SUMMARY OF INSTRUMENT SETUPS IN THE TRAVERSE :

SETUP STATION	BACKSIGHT STATION	FORESIGHT STATION	
STN2		STN1	BACKSIGHT ONTO AZIMUTH BEARING
STN1 STN2		STN8	
STN8 STN1		STN7	
STN7 STN8		STN6	
STN6 STN7		STN5	
STN5 STN6		STN4	
STN5 STN6		STN4	
STN4 STN5		STN2	FORESIGHT ONTO AZIMUTH BEARING
STN2 STN4			

TRAVERSE INITIAL DETAILS :

STATION	--BEARING--	HORIZONTAL -DISTANCE-	SCALE -FACTOR-	M.S.L. -FACTOR-	REDUCED -DISTANCE-	CALCULATED CO-ORDINATES		
						----X----	----Y----	----Z----
		270 0 0.00					1100.000	1100.000
STN2 55.685		90 0 0.00	66.1950	1.000000	1.000000	66.1950	1166.195	1100.000
STN1 54.311		114 47 16.00	59.5930	1.000000	1.000000	59.5930	1220.298	1075.015
STN8 58.797		12 2 52.00	23.1070	1.000000	1.000000	23.1070	1225.121	1097.613
STN7 50.767		271 59 55.00	23.0530	1.000000	1.000000	23.0530	1202.082	1098.417
STN6 51.478		291 20 1.00	65.3360	1.000000	1.000000	65.3360	1141.223	1122.186
STN5 52.348		274 21 37.00	41.4570	1.000000	1.000000	41.4570	1099.886	1125.338
STN4 53.014		179 44 38.00	25.3400	1.000000	1.000000	25.3400	1099.999	1099.998
STN2 55.685		90 0 0.00						

STORED CO-ORDINATES FOR FINAL INSTRUMENT STATION (STN2) 1100.000 1100.000 55.685  
CLOSING AZIMUTH BEARING : 90 0 0.00

ANGULAR MISCLOSURE : + 0 0 0.00  
ADJUSTMET PER STATION : - 0 0 0.00  
DISTANCE MISCLOSURE : 0.002  
PARTIAL MISCLOSURE DX : -0.001  
DY : -0.002  
DZ : -0.000  
BEARING OF MISCLOSURE : 216 14 6.49  
LENGTH OF TRAVERSE : 304.0810  
ACCURACY 1 IN : 151312

TRAVERSE DETAILS AFTER ANGULAR ADJUSTMENT :

STATION	ADJUSTED --BEARING--	-DISTANCE-	CALCULATED CO-ORDINATES		
			----X----	----Y----	----Z----
		270 0 0.00			
STN2		90 0 0.00	1100.000	1100.000	55.685
STN1		114 47 16.00	1166.195	1100.000	54.311
STN8		12 2 52.00	1220.298	1075.015	58.797
STN7		271 59 55.00	1225.121	1097.613	50.767
STN6		291 20 1.00	1202.082	1098.417	51.478
STN5		274 21 37.00	1141.223	1122.186	52.348
STN4		179 44 38.00	1099.886	1125.338	53.014
STN2		90 0 0.00	1099.999	1099.998	55.685
		DZ			-0.000
BEARING OF MISCLOSURE		:	216 14 6.49		
LENGTH OF TRAVERSE		:	304.0810		
ACCURACY 1 IN		:	151312		

TRAVERSE DETAILS AFTER BIRD'S METHOD OF ADJUSTMENT :

ADJUSTED	ADJUSTED	CALCULATED CO-ORDINATES	TOTAL CUMULATIVE ERRORS
----------	----------	-------------------------	-------------------------

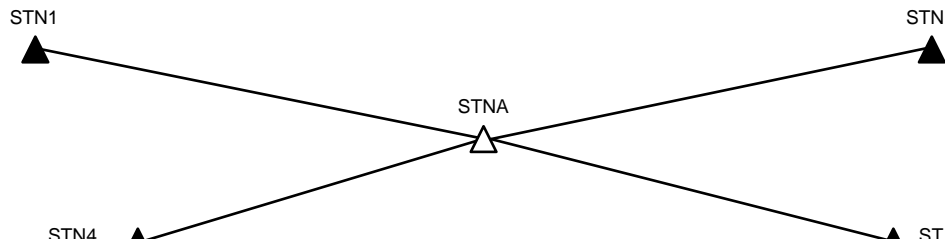
STATION	--BEARING--	-DISTANCE-	----X----	----Y----	---Z---	----X----	----Y----	---Z---
		270 0 0.00						
STN2					1100.000	1100.000	55.685	0.000 0.000 0.000
		89 59 59.93	66.1953					
STN1					1166.195	1100.000	54.311	0.000 0.000 0.000
		114 47 16.00	59.5930					
STN8					1220.298	1075.015	58.797	0.000 0.000 0.000
		12 2 52.04	23.1078					
STN7					1225.121	1097.613	50.767	0.001 0.001 0.000
		271 59 55.00	23.0530					
STN6					1202.082	1098.418	51.478	0.001 0.001 0.000
		291 20 1.00	65.3360					
STN5					1141.223	1122.187	52.348	0.001 0.001 0.000
		274 21 37.00	41.4567					
STN4					1099.886	1125.338	53.014	0.001 0.001 0.000
		179 44 38.00	25.3393					
STN2					1100.000	1100.000	55.685	0.001 0.002 0.000
		90 0 0.00						

STORED CO-ORDINATES FOR FINAL INSTRUMENT STATION (STN2) 1100.000 1100.000 55.685  
 CLOSING AZIMUTH BEARING : 90 0 0.00  
 DISTANCE MISCLOSURE : 0.002  
 PARTIAL MISCLOSURE DX : -0.001  
 DY : -0.002



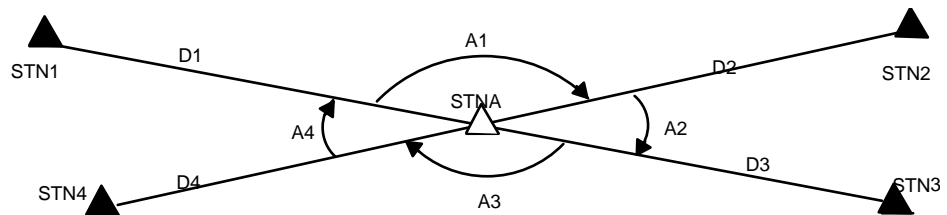
## Calculation of station by intersecting rays and resectioning

The mathematical calculations used for calculating stations by intersecting rays and by resectioning are very similar. Figure 5 - 24 shows four known stations STN1, STN2, STN3 and STN4 and an unknown station STNA. The coordinates of STNA can be determined by intersecting rays methods or by resectioning methods.



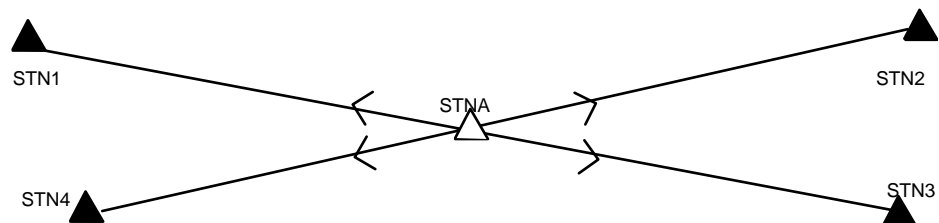
**Figure 5 - 24 Calculation of station by intersecting rays and resectioning**

To be able to calculate the coordinates of STNA the mathematical algorithms need to be supplied with the angles and distances shown below.



**Figure 5 - 25 Calculation of station by intersecting rays and resectioning**

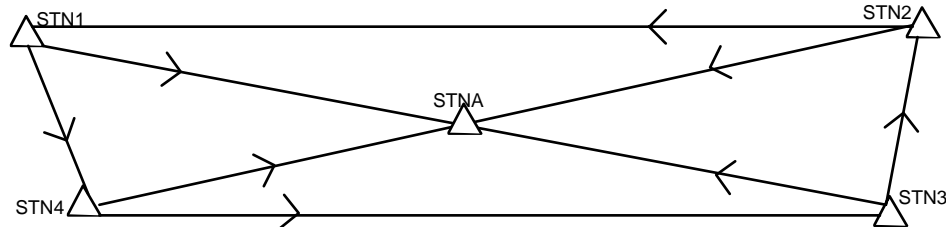
Not every angle and distance is required and this is discussed later. To determine STNA by resectioning the surveyor will set up his instrument once only at the unknown station STNA and take observations onto the known stations:-



**Figure 5 - 26 Use of resectioning to determine STNA**

Hence the angles and distances required for the calculation are easily obtained from the observations.

For **intersecting rays** the surveyor will set the instrument up on each of the known stations, take an observation onto a reference object (ie a known station), and then take an observation onto the unknown station STNA:-



**Figure 5 - 27 Use of intersecting rays to determine STNA**

Again the angles and distances required to calculate STNA can be easily obtained from the observations supplied.

At least three observations are needed to calculate the coordinates of a station. An observation can contain the angle only or the angle and the distance. The observed angles and distances are weighted according to the standard errors off the instrument. The standard errors of the instrument can be coded in fields 5, 6 and 7 of the minor option 189.

A second round of observations can be taken for resectioning or intersecting rays.

The solutions for resectioning and intersecting rays require an estimate of the initial position of the point. This is required to iterate the result from successive approximations until the calculated coordinates agree to within 0.0001 metres. Usually two iterations are required.

Observations which have large residual errors are eliminated and the point is recalculated by a further iteration. The elimination of errors is described next.

### Elimination of errors

A solution is calculated using all the observations supplied. For each observed angle and distance a residual error is calculated. ie the difference between the observed value and the adjusted value. The mean standard error is calculated for angles and distances. If an individual observed value is more than three times the mean standard error then the observation is eliminated. This only applies if the mean standard error is greater than 0.000005 radius (1") for angles or 0.001 model units for distances. The solution is then recalculated using the remaining observations. When a solution has been calculated and there are no more observations to be eliminated the absolute values of the residual errors are checked. If any angle has been adjusted by more than 60 seconds or any distance has been adjusted by more than 2 metres then the whole solution is rejected. (This absolute check can be overridden by an indicator in field 1 of minor option 190).

### Calculation of the station level

The level of the station is calculated from the observations used in the final iteration to calculate the x and y coordinates. A level is calculated from each observation and the mean level for the station is determined by weighting each level in inverse proportion to the square root of the distance of the observation. An absolute check is incorporated and if any level is adjusted by more than 1.0 metres the calculation is rejected. For resectioning, observations to upstations are ignored by the level calculation.

### Recording the observations for resectioning

A typical set of observations for locating a station by resectioning is shown below.

```
200,STN3,,HDL D
201,RESN,,STN2,1040346,22.382,-0.352
201,RESN,,STN4,1702649,24.677,-3.023
201,RESN,,STN5,2883456,24.473,-3.689
201,RESN,,STN1,3282242,48.307,-1.726999
```

Observations which are part of a resectioning analysis have the indicator RESN in field 1 and the name of the station being observed in field 3 as shown above. The RESN observations will usually be grouped together immediately after the 200 record. However, they can be mixed with detail observations if required:-

```
200,STN3,,HDL D
201,RESN,,STN2,1040346,22.382,-0.352
201
201 | detail observations
201 |
201,RESN,,STN4,1702649,24.677,-3.023
201
201 | detail observations
201 |
201,RESN,,STN5,2883456,24.473,-3.689
201
201 | detail observations
201 |
201,RESN,,STN1,3282242,48.307,-1.726
201
201 | detail observations
201 |
999
```

The 200 record contains only the name of the instrument station (this is the station which is being located) and the observation style. The reference station and the horizontal angle datum will be needed only if detail observations are to be processed - the values are then taken from the last RESN observation record. The values which are used are shown in the printed output.

An instrument height can be coded on the 200 record but collimation from the reference object is not permitted.

The RESN observations in the example above are all full observations ie distance information (and level component) is recorded along with the horizontal angle. If the surveyor is sighting onto an upstation he will only be able to record the horizontal angle and partial observations are allowed to accommodate this.

Hence if, for example, STN4 is a church spire the data will be:-

```
200, STN3, , HDL D
201, RESN, , STN2, 1040346, 22.382, -0.352
201, RESN, , STN4, 1702649
201, RESN, , STN5, 2883456, 24.473, -3.689
201, RESN, , STN1, 3282242, 48.307, -1.726999
```

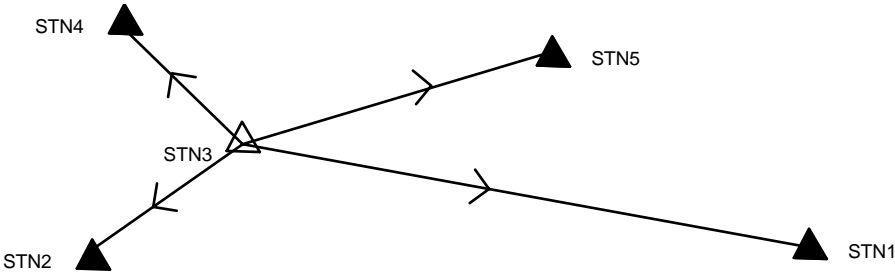
As shown, full and partial RESN observations can be mixed freely.

A minimum of three RESN observations is required to locate a station. However the surveyor is encouraged to supply more.

**Example of resectioning**

Printed output is produced to show a complete analysis of how the observations have been processed. Tables of results are shown for each stage of the calculation.

The example shows the input data and the analysis for the calculation of station STN3 from known stations STN1, STN2, STN4 and STN5.



**Figure 5 - 28 Example of resectioning**

```
200, STN3, , HDL D
201, RESN, , STN2, 1040346, 22.382, -0.352
201, RESN, , STN4, 1702649, 24.677, -3.023
201, RESN, , STN5, 2883456, 24.473, -3.689
201, RESN, , STN1, 3282242, 48.307, -1.726999
```

```

CALCULATION OF STATIONS BY RESECTIONING
-----

STATION STN3 :

CALCULATION OF STATION STN3 : ADJUSTED DIRECTIONS AFTER ITERATION 1

STANDARD ERROR OF DIRECTION IS 3.0 SECONDS

FROM          TO          OBSERVED          ADJUSTED          DIRECTION ADJUSTMENT
DIRECTION     DIRECTION

STN3          STN2  104  3 46.0 104  4 15.4      0  0 29.4
STN3          STN4  170  26 49.0 170  26 31.2      -    0  0 17.8
STN3          STN5  288  34 56.0 288  34 51.3      -    0  0  4.7
STN3          STN1  328  22 42.0 328  X22 35.2      -    0  0  6.8

    4 DIRECTIONS OBSERVED.      MEAN STANDARD ERROR =    0  0 11.771

CALCULATION OF STATION STN3 : ADJUSTED DISTANCES AFTER ITERATION 1

STANDARD ERROR OF DIRECTION IS 5 MM + 5 PPM.

FROM          TO          OBSERVED          ADJUSTED          DISTANCE
DIRECTION     DIRECTION     ADJUSTMENT

STN3          STN2  22.382      22.381      -0.001
STN3          STN4  24.677      23.858      -0.819
STN3          STN5  24.473      24.470      -0.003
STN3          STN1  48.307      48.306      -0.001

    4 DISTANCES OBSERVED.      MEAN STANDARD ERROR =    0.273

CALCULATION OF STATION STN3 : SUMMARY OF ANALYSIS FOR ITERATION 1

FROM          TO          WCB          DISTANCE          STANDARD ERROR          STANDARD ERROR
OF WCB          OF DISTANCE

STN3          STN2  239  21 16.5 22.381      0  0 29.4      -0.001
STN3          STN4  305  43 32.4 23.858      - 0  0 17.8      -0.819
STN3          STN5   63  51 52.4 24.470      - 0  0  4.7      -0.003
STN3          STN1  103  39 36.3 48.306      - 0  0  6.8      -0.001
SOLUTION ACCEPTED.

CALCULATION OF STATION STN3 : LEVEL INFORMATION

FROM          TO          DISTANCE          CALCULATED
LEVEL

STN3          STN2  22.382      56.037
STN3          STN4  24.677      56.037
STN3          STN5  24.473      56.037
STN3          STN1  48.307      56.037

WEIGHTED MEAN LEVEL =    56.037

STATION STN3 CREATED WITH COORDINATES    1119.255    1111.4087    56.037
    
```

**Recording the observations for intersecting rays**

A typical set of data for locating a station by intersecting rays is shown below.

```

200 , STN5 , STN4 , HDLD , 2750457
201 , INTS , , STN9 , 0750946 , 76.744 , -11.728
200 , STN6 , STN5 , HDLD , 1592642
201 , INTS , , STN9 , 2443201 , 46.241 , -10.858
200 , STN7 , STN6 , HDLD , 0601526
201 , INTS , , STN9 , 1354857 , 46.244 , -10.147
    
```

Observations which are part of an intersecting ray analysis have the indicator INTS in field 1 and the name of the station being observed (ie the station being fixed) in field 3.

Both stations on the 200 record are known and a full set up record is required.

The INTS observations can be mixed freely with detail observations for the set up and if required, INTS observations can be recorded for more than one unknown station:-

```

200,STN5,STN4,HDL,2750457
201,INTS,,STN9,0750946,76.744,-11.728
201
201      | detail observations
201
200,STN6,STN5,HDL,1592642
201
201      | detail observations
201
201,INTS,,STN9,2443201,46.241,-10.858
201
201      | detail observations
201
200,STN7,STN6,HDL,0601526
201
201      | detail observations
201
201,INTS,,STN9,1354857,46.244,-10.147
    
```

If the station being located is an upstation eg a church spire then all the INTS observations will contain only the horizontal angle and not distance and level components:-

```

200,STN5,STN4,HDL,2750457
201,INTS,,STN9,0750946
200,STN6,STN5,HDL,1592642
201,INTS,,STN9,2443201
200,STN7,STN6,HDL,0601526
201,INTS,,STN9,1354857
    
```

A minimum of three INTS records is required to locate a station however the surveyor is encouraged to supply more.

### Example of intersecting ray

Printed output is produced to show a complete analysis of how the observations have been processed. Tables of results are shown for each stage of the calculation.

The example shows the input data and the analysis for the calculation of station STN9 from known stations STN4, STN5, STN6 and STN7.

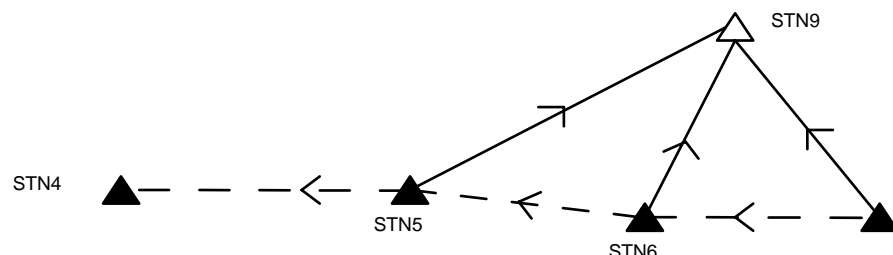


Figure 5 - 29 Example intersecting ray

Output

```

CALCULATION OF STATIONS BY INTERSECTING RAYS
-----
STATION STN9 :
CALCULATION OF STATION STN9 : ADJUSTED DIRECTIONS AFTER ITERATION 1

STANDARD ERROR OF DIRECTION IS 3.0 SECONDS

FROM      TO      OBSERVED      ADJUSTED      RESIDUAL
          TO      DIRECTION     DIRECTION     ERROR
STN5      STN9    75  9 46.0  75  9 40.4    -0  0  5.6
STN6      STN9   244 32  1.0 244 31 56.2    -0  0  4.8
STN7      STN9   135 48 57.0 135 48 50.5    -0  0  6.5

    4 DIRECTIONS OBSERVED.      MEAN STANDARD ERROR =      0  0  4.937

CALCULATION OF STATION STN9 : ADJUSTED DISTANCES AFTER ITERATION 1

STANDARD ERROR OF DISTANCES 5 MM + 5 PPM.

FROM      TO      OBSERVED      ADJUSTED      DISTANCE
          TO      DISTANCE      DISTANCE      ADJUSTMENT
STN5      STN9    76.744    76.745    0.001
STN6      STN9    46.241    46.243    0.002
STN7      STN9    46.244    46.247    0.003

    3 DISTANCES OBSERVED.      MEAN STANDARD ERROR =      0.002

CALCULATION OF STATION STN9 : SUMMARY OF ANALYSIS FOR ITERATION 1

FROM      TO      WCB          DISTANCE      STANDARD ERROR      STANDARD ERROR
          TO               DISTANCE      OF WCB            OF DISTANCE
STN5      STN9    74 26 20.5  76.745    -0  0  5.6    0.001
STN6      STN9    16 25 15.4  46.243    -0  0  4.8    0.002
STN7      STN9    347 33 19.6  46.247    -0  0  6.5    0.003

                                SOLUTION ACCEPTED.

CALCULATION OF STATION STN9 : LEVEL INFORMATION

FROM      TO      DISTANCE      CALCULATED
          TO      DISTANCE      LEVEL
STN5      STN9    76.744    40.620
STN6      STN9    46.241    40.620
STN7      STN9    46.244    40.620

                                WEIGHTED MEAN LEVEL =      40.620

STATION STN9 CREATED WITH COORDINATES      1215.155    1142.774    40.620
    
```

Fly stations - permanent and temporary

Fly stations are created from a single observation. The indicator FLY is coded in field 1 and the name of the station to be created is coded in field 3:-

```

200STN2STN1HDL D 2794215
201FLY STNC 183701 20.215 1.755 1096.868 1080.029 57.440
999
    
```

Station STNC can be used like any other station in the survey and at the end of the run it will be stored in the stations string.

The surveyor can also create temporary fly stations - these are used during the survey but are not retained in the stations string when the processing of the data is completed. The temporary fly station indicator FLYT is required in field 1 and the name of the temporary station in field 3:-

```
200STN2STN1HDLD 2794215
201FLYT TEM1 172600 20.202 1.855
999
```

```
1097.283 1079.982 57.540
```

An example showing the use of temporary stations is given in the section which describes the recalling of observations.

## String labels

### Coding the string labels

The need to achieve a balance between the work carried out in the field and the work required in the office to complete the survey has already been discussed. The coding of string labels is an important part of achieving a satisfactory balance and the principles were discussed in the recorded strings section.

Sometimes the surveyor will want to concentrate on recording a single feature completely before moving onto the next feature. In this case the chainman will move along the feature and the string will be recorded sequentially. At the other extreme when individual points are being recorded (trees, lamp posts, gullies) it is quite likely that no two successive observations will be stored in the same string. In this case the strings will be recorded **randomly**.

Generally strings recorded sequentially will have partial string labels and strings recorded randomly will have full four character labels. MOSS will generate a unique full label from partial labels and this is described in the next section. The surveyor will often want to combine the advantages of coding partial labels with the facility of recording strings randomly. This is useful if two linear features followed similar directions - the chainman can walk along their length taking points alternately on each feature. This method of recording strings is known as the **combined** mode.

Sequential, random and combined modes are described further below. The examples given are all taken from the same survey - illustrating the point that, in practice, no one method is adequate in isolation. The surveyor will invariably want to use all three methods in order to adapt MOSS to his individual style of working.

A feature common to all three methods of recording points is that when points are sent to a string they are stored in the order in which they appear in the data. Hence the need for the surveyor to 'think in strings' in the field.

### Recording strings sequentially

If a string is being recorded sequentially there is no need to code the string label on each observation - the previous label is used until a new one is coded. Partial labels will usually be coded although full four character labels can be given. An example is given in Figure 5 - 30.



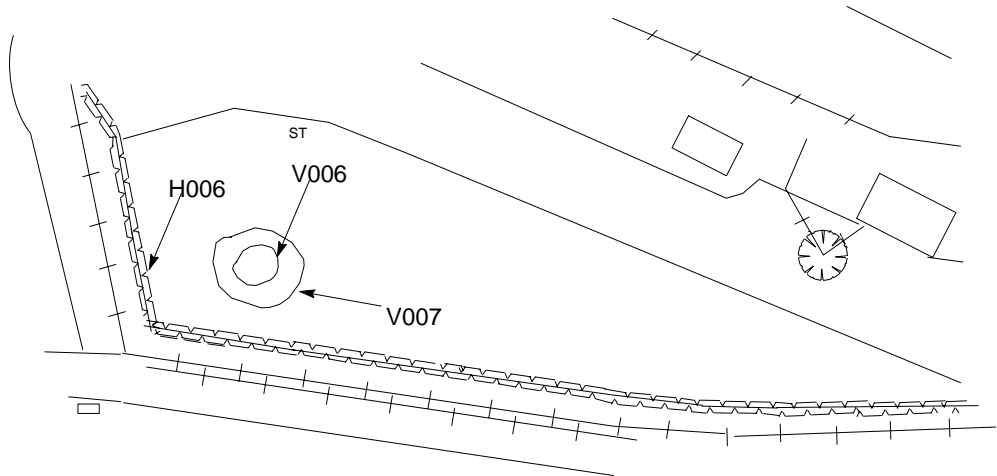


Figure 5 - 30 Example of sequential string recording

200STN3STN5HDLDD	1003027									
201	H	0300816.398	-3.037	300	*	1109.584	1124.651	53.000	H003	
201		3544843	12.498	-1.537	301	*	1110.920	1120.721	54.500	
201		2920203	7.221	-0.667	302	*	1112.268	1109.587	55.370	
201		1433017	16.976	-0.837	303	*	1135.501	1106.484	55.200	
201		1382042	26.992	-0.987	304	*	1145.686	1105.934	55.050	
201		1365734	36.107	-1.637	305	*	1154.779	1104.942	54.400	
202		Y1223840	0.861	-0.117	306	*	1120.114	1111.468	59.920	V006
					W605 MOSS CURVE FITTING APPLIED.					
202		3155114	1.024	-0.117	307	*	1118.244	1111.572	55.920	
202		2261232	0.884	-0.117	308	*	1119.108	1110.536	55.920	
202		1210217	0.891	-0.117	309	*	1120.142	1111.495	55.920	
202					306	*	1120.114	1111.468	55.920	
202	Y	393530	2.020	-1.137	310	*	1119.359	1113.425	54.900	V007
					W605 MOSS CURVE FITTING APPLIED.					
202		3360354	1.999	-1.047	311	*	1117.514	1112.390	54.990	
202		3073447	2.073	-1.017	312	*	1117.183	1111.442	55.020	
202		2794410	1.967	-0.987	313	*	1117.501	1110.518	55.050	
202		2352949	1.80	-0.987	314	*	1118.672	1109.701	55.050	
202		1934412	1.835	-1.007	315	*	1119.969	1109.718	55.030	
202		1414702	1.945	-1.057	316	*	1121.133	1110.900	54.980	
202		972802	1.820	-1.107	317	*	1120.844	1112.295	54.930	
202		583128	1.924	-1.137	318	*	1119.972	1113.194	54.900	
202					310	*	1119.359	1113.425	54.900	

**Recording strings randomly**

A full label is given on the observation record. This mode is useful for recording features which are stored in point strings, eg lamp posts and trees. These features are usually stored in strings where the label has a predetermined meaning - in Figure 5 - 31 PTR1, PTR2 and PTR3 are used to group together trees of the same size. The technique can also be used when linear features are being recorded in separate lengths. Random observations may be interspersed with sequential observations.

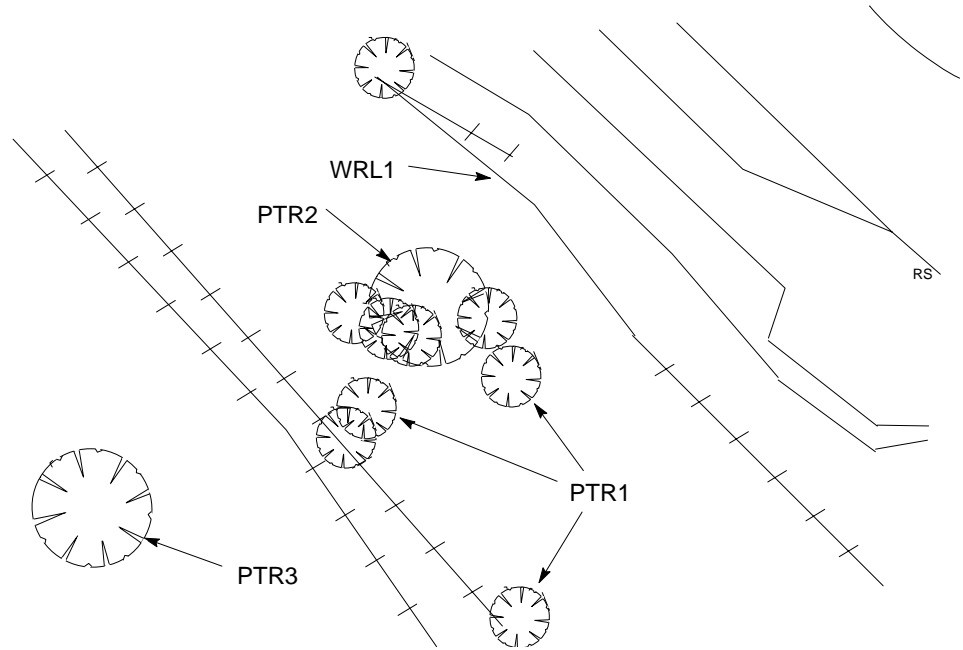


Figure 5 - 31 Example use of point strings

201	PTR1	1814822	41.627	-7.268	6021	*1172.1961149.999	45.080	PTR1
201	WRL				603	* 1172.196 1149.999	45.080	WRL1
201		1952856	43.359	-9.298	604	* 1179.420 1142.707	43.050	
201		2024246	44.125	-8.888	605	* 1182.413 1138.011	43.460	
201	F				606	* 1182.413 1138.011	43.460	F003
201		2212203	55.106	-6.978	607	* 1196.283 1124.457	45.370	
201	PTR3	2012737	24.490	-5.448	6071	*1163.8871131.467	46.900	PTR3
201	PTR1	1973056	37.769	-7.438	6072	*1175.1081138.870	44.910	PTR1
201	PTR2	1972319	39.694	-7.748	6073	*1176.7961139.799	44.600	PTR2
201	PTR1	1991636	40.616	-7.948	6074	*1178.1971138.999	44.400	PTR1
201		2001402	34.645	-6.548		* 1172.996 1135.999	45.800	
201		1994351	35.436	-6.748		* 1173.597 1136.599	45.600	

### Recording strings in combined mode

This method allows strings to be recorded in sections and also allows partial labels to be given. A partial label for combined mode will typically consist of an initial character, two blank characters, and a sub identifier in the fourth character position:-

eg H--A, C--A, C--B

Alternatively two initial characters or a two-character sub-identifier can be given:-

eg HL-A, C-AB

Figure 5 - 32 shows how these labels are used. Note that full labels and partial labels with no sub-identifier can be freely interspersed with the combined mode labels.

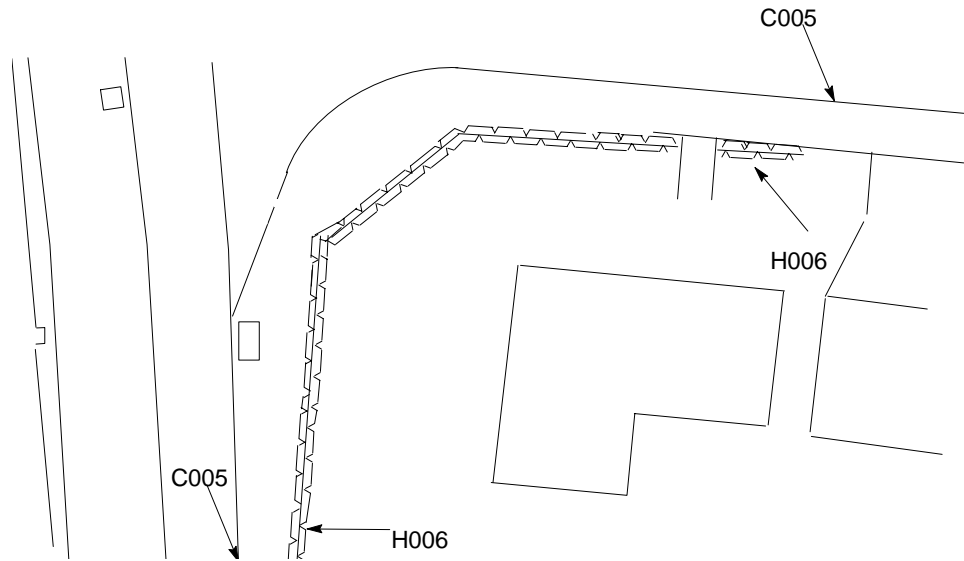


Figure 5 - 32 Example of partial string labels

201	C A	183701	20.215	1.755	1	*1096.868	1080.029	57.440	C005
201	PLP1	172600	20.202	1.855	2	*1097.283	1079.982	57.540	PLP1
201	H A	123404	20.096	1.955	3	*1098.996	1079.929	57.640	H006
201	C A	202043	14.048	1.215	4	*1097.406	1086.194	56.900	C005
201	H A	103649	13.983	1.415	5	*1099.778-1086.019		578.100	H006
201REMS	REC	224057	9.302	0.815	6	*1097.911	1090.936	56.500	REC0
201REMS	213708	10.181	0.815	-0.45	7	*1097.898	1090.038	56.500	
202	C A	252717	9.379	0.755	9	*1097.454	1090.973	56.440	C005
W605 MOSS CURVE FITTING APPLIED.									
202	275447	7.296	0.525		10	*1097.720	1093.069	56.210	
202DISC	285302	5.278	0.375		11	*1098.266	12095.015	56.060	
201	V					*1098.266	1095.015	56.060	V000
201	260223	3.306	0.285		12	*1099.070	1096.827	55.970	
202	C A					*1099.070	1096.827	55.970C005	
W605 MOSS CURVE FITTING APPLIED.									
201	H A	04545	5.386	0.575	13	*1100.837	1094.679	56.260	H006
202	C A	3271055	1.210	0.105	14	*1100.818	1099.108	55.790	C005
202	2625305	5.720	-0.035		15	*1105.475	1101.655	55.650	
202	2683330	9.653	-0.165		16	*1109.471	1101.866	55.520	
201	H A	2823116	6.694	0.065	17	*1106.686	1099.671	55.750	H006
201	C A	2803326	26.195	-0.535	18	*1126.192	1099.610	55.150	C005
202	C B	335538	21.353	1.715	19	*1091.239	1080.527	57.400	C006
W605 MOSS CURVE FITTING APPLIED.									
202	374731	18.058	1.415		20	*1091.498	1084.069	57.100	
201	WALA	384632	18.796	1.515	21	*1090.867	1083.572	57.200	WALA
202	C B	602409	10.974	0.585	22	*1091.508	1093.049	56.270	C006
201	WALA	614315	11.467	0.685	23	*1090.962	1092.946	56.370	WALA
201	610614	11.254	0.685		24	*1091.205	1092.979	56.370	
201	625756	10.979	0.685		25	*1091.202	1093.433	56.370	
201	635907	11.219	0.685		26	*1090.891	1093.450	56.370	
202	C B	1003632	9.055	-0.905	27	*1090.946	1100.143	55.590	C006
202	1203342	10.204	-0.405		28	*1090.465	1103.633	55.280	
201	WALA	1151609	10.371	-0.305	29	*1090.009	1102.783	55.380	WALA
201	1163453	10.192	-0.305		30	*1090.247	1102.959	55.380	

**Generation of labels and relabelling of strings**

MOSS has to ensure that strings have unique labels. This is a two stage process for strings created by a ground survey. Firstly the labels coded in the data are analysed - full labels are generated from partial labels and are incremented as necessary to avoid duplicate labels. Secondly the set of new labels must be compared to the labels already in the model to ensure that none of the new labels already exist. If there is a conflict the new strings are relabelled.

- ◇ *Partially labelled P strings are prohibited.*
- ◇ *Use of the label 0000 is prohibited.*

**Stage 1 - Processing the labels coded in the data**

Partial labels are completed by overlaying the label given onto the label 0000, hence X--- becomes X000 and -X-X becomes 0X0X.

If the full label generated has already been allocated to a previous string the label is incremented. The character sequence for incrementing labels is 0 to 9, then A to Z. Hence

0000,0001,....0009,000A,000B,....000Z,0010,0011,0012

When a duplicate label is being resolved MOSS will check from the start of the sequence for the label to see if there are any gaps in the sequence. These gaps will be used before incrementing the label.

If the surveyor has coded C000, C00L and C00R as full labels followed by the partial labels C---, C---, C--- the new labels created will be C001, C002 and C003.

In 'combined mode' (see 'Recording strings in combined mode') the fourth character coded is purely an indicator and does not form part of the final string label. So if the following labels were coded, C--A, CA-B, C-BA the new labels created would be C001, CA01, C002.

**Stage 2 - Merging the new labels into the existing model**

If a new label is already used for a string in the existing model the following rules apply:-

- Strings in the existing model are never relabelled
- P strings are never relabelled - the points will be appended to the existing string.
- The new label will be relabelled in the same way as described above ie if there are no gaps in the sequence the label will be incremented.
- If a full label is coded in the data and the label is not in the existing model then its label will be retained. For example:

Labels in the Existing Model	Labels coded in the Data	Final Labels for the New Strings
0010	0---	0000
0002	0002	0003
A001	A001	A004
A005	A002	A002

A009	A003 ABCD	A003 ABCD
	H001 H002	H001 H002
PTR1 PTR3	PTR- PTR- PTR3	PTR0 PTR2 PTR3
X099 X100	X— X002	X000 X002

**Recording points**

**The basic observation**

The basic observation for a point gives the information needed to enable MOSS to calculate the coordinates for the point identified by the target, the staff, or the end of the tape. These base measurements from the nucleus of the observation record - the other information given on the observation record describes how the basic observation is to be used, ie string label where point will be stored, observation is to be used to define a new station, observation is to be adjusted.

The components of the basic observation depend on the observation style specified on the set up record - see section on setting up the instrument at a station.

**Geometric observations**

Geometric observations are made up of three components: horizontal angle, distance component and level component. Target heights are optional and are described in the next section. Instruments of different makes supply different components eg horizontal distance (HD) or slope distance (SD), vertical angle (VA) or level difference (LD).

The following example shows the set up record and an observation record for an instrument which supplies horizontal distance and level difference - observation style HDLD.

200STNBSTNAHDL	0494015									
201	C	047155	56.189	1.691			*	1278.619	1506.483	75
201		2325653	41.981	-0.505			*	1320.878	1594.987	73

the observation record contains the horizontal angle (0475155) in field 4, the horizontal distance (56.189) in field 5, and the level difference (1.691) in field 6.

If the instrument supplied the components in the reverse order ie level difference followed by horizontal distance then the observation style LDHD would be used:-

200STNBSTNAHDL	0494015										
201	C	047155	1.691	56.189			*	1278.619	1506.483	75.390	C002
201		2325653	-0.505	41.981			*	1320.878	1594.987	73.194	

Similarly for an instrument supplying vertical angle and slope distance:-

```
200STNBSTNAVASD 0494015
201 C 047155 56.197 0004804 * 1278.619 1506.483 75.
201 2325653 41.990 3584754 * 1320.878 1594.987 73.
```

### 3 Stadia observations

The components of a measurement are horizontal angle (field 4), vertical angle (field 5) and the stadia readings (fields 6, 7, 8). Hence:-

```
200STNBSTNASTAD 0494015 1.586
201 C04751550004804 0.400 0.681 0.962 * 1278.619 1506.483 75.390 C000
201 23256533584754 1.000 1.210 1.420 * 1320.879 1594.987 73.195
```

The stadia readings may be entered in any order - the maximum and minimum values are automatically detected. The differences between the upper and lower stadia readings and the middle reading are checked for agreement within a tolerance of 0.01 units.

### Chain and offset observations

The components of the basic measurement are the distance along the chain (field 5) and the offset (field 6). Hence:-

```
200STNZSTNQCHOF
201 F00A 50 -8.1 *1286.968 1509.369 -999.000 F00A
201 V00A 50 -5.3 *1284.433 1510.559 -999.000 V00A
```

Extra facilities for recording points in a chain and offset survey are described in the TIE Observations and PIV/LNE Observations sections.

If the surveyor wishes to assign a level to a point the level can be given in field 7.

```
200STNZSTNQCHOF
201 F00A 50 -8.1 77.8 *1286.968 1509.369 77.800 F00A
201 V00A 50 -5.3 77.4 *1284.433 1510.559 77.400 V00A
```

If the distance along a chain is not supplied on a record then the distance recorded on the previous record is assumed.

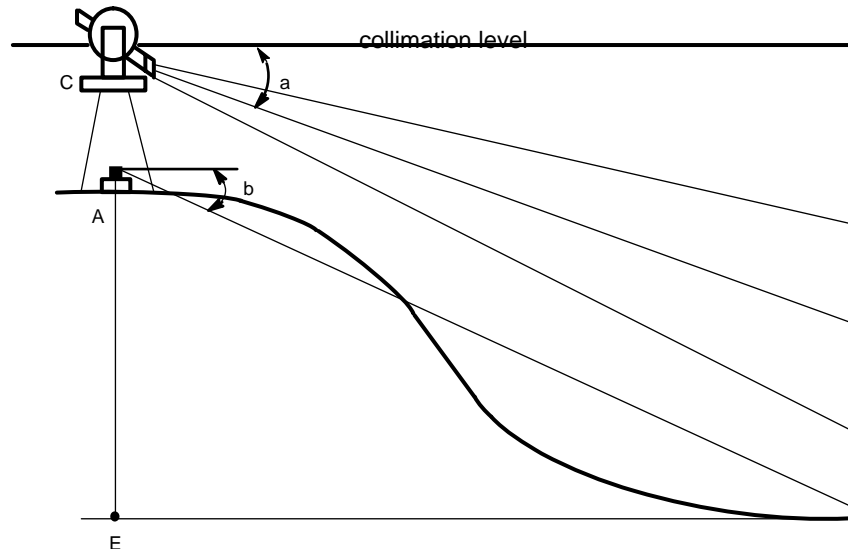
### Real coordinates

For instruments which supply reduced coordinates directly an observation record contains the coordinates in fields 5, 6 and 7

```
200 REAL
201 CHAN 1278.619 1506.483 75.390 *1278.619 1506.483 75.390 CHAN
201 1320.8791594.987 73.194 * 1320.879 1594.987 73.194
```

### Changing target heights

For geometric observations a target height will often be supplied with the basic observation described in the basic observation section. The target height will be coded to be consistent with the method used for setting the height of collimation - see earlier section on setting up the height of collimation.



**Figure 5 - 33 Target height**

a	-	observed vertical angle
C - D	-	observed slope distance
b	-	true vertical angle
E - B	-	horizontal distance
A - C	-	instrument height
G	-	bottom stadia
B - D	-	Target height/centre stadia
H	-	top stadia

Hence:- Level of the observed point = Collimation level + observed level difference - target height

There are several combinations of coding collimation details on the set up record with target heights on the observation records and they are described below.

If a target height is coded on an observation record then its value is carried forward and used on subsequent observations until a new target height is coded. Hence the surveyor only has to book the target height when its value changes.

Negative target heights can be coded if soffits are being observed.

Case 1 - Collimation details given, target heights given

In the example shown below the height of the instrument has been coded on the set up record and the target height coded on the first observation record.

180	STN1	940	980	100.0					
180	STN2	1030	1010.0	110.0					
200	STN1STN2HDLD	000000		1.5					
201	CIR	33151127	134.387	5.0	1.5	*1000.500	1099.998	105.000	CIR3
201	3281337	148.060	3.75			* 1034.759	1093.765	103.750	
201	3423549	158.545	2.5			* 1068.529	1072.827	102.500	
201	3564155	163.074	1.25	2.0		* 1091.479	1040.392	100.750	
201	104511.1	161.436	0.0	1.5		* 1099.987	1001.580	100.000	
201	245756.5	153.707	-1.25	2.0		* 1092.710	962.518	98.250	
201	393540.6	140.251	-2.50	1.5		* 1070.795	929.374	97.500	
201	550325.9	121.736	-3.75	2.0		* 1037.704	907.380	95.750	
201	721053.3	99.194	-5.0			* 998.659	900.009	94.500	

The first three observations have a target height of 1.5 and the next one has a non standard target height (2.0). Note that the target height must be coded when reverting to the standard target height for the fifth observation.

Case 2 - Collimation details given, target heights not given

For instruments which can take measurements directly from the ground a height of instrument will be coded but no target heights will be required.

180	STN1	940	980	100.0					
180	STN2	1030	1010.0	110.0					
200	STN1STN2HDLD	000000		1.5					
201	C3151127	134.387	5.0			* 1000.500~	1099.998	106.500	C000
						W582 ZERO	TARGET HEIGHT ASSUMED		
201	3281337	148.060	3.75			* 1034.759	1093.765	105.250	
201	3423549	158.545	2.5			* 1068.529	1072.827	104.000	
201	3564155	163.074	1.25			* 1091.479	1040.392	102.750	
201	104511.1	161.436	0.0			* 1099.987	1001.580	101.500	
201	245756.5	153.707	-1.25			* 1092.710	962.518	100.250	

Another example of this combination is where the surveyor does not want to record target heights but the height of the instrument is less than the standard target height. He can compensate for this by coding a negative instrument height.

180	STN1	940	980	100.0					
180	STN2	1030	1010.0	110.0					
200	STN1STN2HDLD	000000		-0.15					
201	C3151127	134.387	5.0			* 1000.500~	1099.998	104.850	C001
						W582 ZERO	TARGET HEIGHT ASSUMED		
201	3281337	148.060	3.75			* 1034.759	1093.765	103.600	
201	3423549	158.545	2.5			* 1068.529	1072.827	102.350	
201	3564155	163.074	1.25			* 1091.479	1040.392	101.100	
201	104511.1	161.436	0.0			* 1099.987	1001.580	99.850	
201	245756.5	153.707	-1.25			* 1092.710	962.518	98.600	

Case 3 - Collimation details not given, target heights not given

In this case the height of the instrument is the same as the standard target height and all points can be observed without having to use any non standard target heights.

180	STN1	940	980	100.0					
180	STN2	1030	1010.0	110.0					
200	STN1STN2HDLD	000000							
201	C3151127	134.387	5.0			* 1000.500~	1099.998	105.000	C002
201	3281337	148.060	3.75			* 1034.759	1093.765	105.200	
201	3423549	158.545	2.5			* 1068.529	1072.827	102.500	
201	3564155	163.074	1.25			* 1091.479	1040.392	101.250	
201	104511.1	161.436	0.0			* 1099.987	1001.580	100.000	
201	245756.5	153.707	-1.25			* 1092.710	962.518	98.750	



Case 4 - Collimation details not given, target heights given

This case allows a non standard target height to be used in a survey where the height of the instrument and the standard target height are the same and are not being coded (Case 3).

180	STN1		940	980	100.0			
180	STN2		1030	1010.0	110.0			
200	STN1STNZHDL	000000			-0.15			
201	CIRC	3151127.	134.387	5.0		*1000.500-1099.998	105.000	CIR3
201		3281337.148.060	3.75			* 1034.759	1093.765	103.600
201		3423549.158.545	2.5			* 1068.529	1072.827	102.350
201		3564155.163.074	1.25			* 1091.479	1040.392	101.100
				0.0		W582 ZERO	TARGET HEIGHT ASSUMED	
201		104511.1161.436	0.0			* 1099.987	1001.580	100.000
201		245756.5153.707	-1.25	0.5		* 1092.710	962.518	98.250
201		393540.6140.251	-2.50	0.0		* 1070.795	929.374	97.500
201		550325.9121.736	-3.75	0.5		* 1037.704	907.380	95.750
201		721053.3 99.194	-5.0			* 998.659	900.009	94.500

The target heights coded are not the actual target height but the actual target height minus the standard target height. Note that the results in this example are the same as those in example for Case 1.

Coding point number

These point numbers are really identification tags and have no influence on how strings are stored in the model. They are used for recalling observations (see next section) and with the points string (see later section). The point number is coded in field 10 of an observation record. The surveyor can code a point number on each record required or can allow MOSS to allocate the point numbers. The following rules apply:-

- If no point numbers are coded then MOSS will allocate point number 1 to the first observation and increment (by 1) the point numbers for subsequent observations.
- If the surveyor codes a point number for each observation then these values are retained. They do not have to be in any particular sequence.
- If an observation is given a point number and is followed by observations with no point number then MOSS will increment the blank observations from the value coded.

The point numbers do not have to be unique within a set of data. However, if the point numbers are to be used to generate strings from the points string later then it is advisable to have unique point numbers. The surveyor may wish to allocate a different range of point numbers to different instrument set ups. For example:-

```

200 , STN2 , STN1 , HDLD , 2794215
201 , , , C A , 183701 , 20.215 , 1.755 , , , , 2000
|
|
|
200 , STN4 , STN2 , HDLD , 153627
201 , , , C , 3481527 , 13.800 , 1.666 , , , , 4000
|
|

```

**Recalling observations**

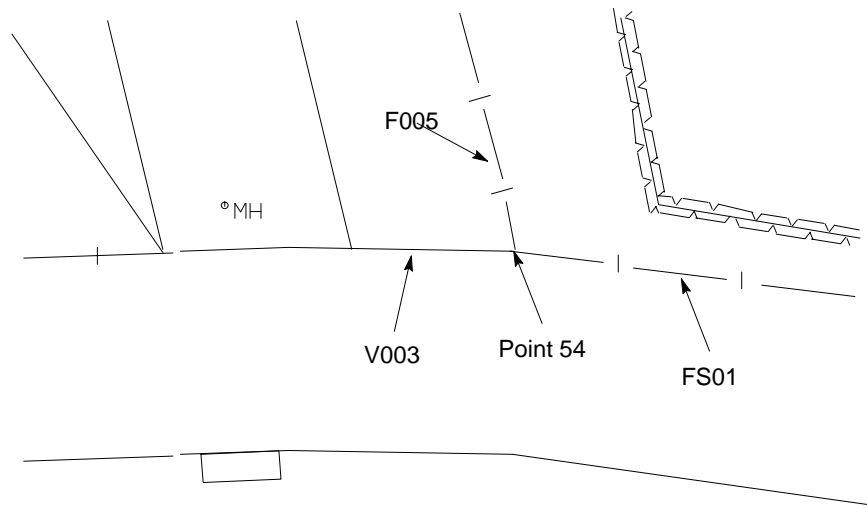
The surveyor may wish to recall an observation for two reasons:-

- To store the same point in two different strings eg where a hedge and a gate meet.
- To generate an extended point from the previous point (see example in next section for recording a hedge point.)

There are three ways to recall a point. In each case the fields which normally contain the basic observations are left blank.

**Absolute point number**

The observation to be recalled is specified by coding the absolute point number coded on a previous observation. In the example shown in Figure 5 - 34 the point (pt 54) is required in three strings (V003, F005 and FS01).



**Figure 5 - 34 Example absolute point number**

202	FO D	2260224	10.946	-.405		49	*1106.486	1108.818	55.280	F001	
201	V					49	* 1106.486	1108.818	55.280	V003	
201		2372605	13.046	-0.435		53	* 1109.654	1108.775	55.250		
201		2414611	14.158	-0.435		54	* 1111.167	1108.704	55.250		
201	PMHR	2310349		12.506	-0.425		54	*1108.264	1109.387	55.260	PMHR
201	F B						54	*1111.167	1108.704	55.250	F005
201	FS A						54	*1111.167	1108.704	55.250	FS01
201	FS A	2695702	34.497	-0.735		62	*1133.998	1105.844	54.950	FS01	

MOSS will always search backwards through the data. Hence if the requested point number is not unique then the last one will be used.

The example below shows two observations being recalled to create fly stations which are then used to record chain and offset observations.

201	BLC	1995632	18.166	-0.804		454	*1101.179	1143.459	52.210	BLCO
201		2354229	9.480	-0.774		455	*1105.961	1132.618	52.240	
201FLYT	TEM1					454	*1101.179	1143.459	52.210	
201FLYT	TEM2					455	*1105.961	1132.618	52.540	
200TEM1TEM2CHOF										
201	B		5.55		0	4561	*1103.419	1138.381	-999.000	B000
201			5.55		1.45	4562	*1102.092	1137.796	-999.000	
201			6.65		1.45	4563	*1102.536	1136.789	-999.000	

**Relative point number**

The observation required is defined by giving its position relative to the current observation record. In the following example a point number of -3 recalls the observation 3 before the current observation record.

201		1733045	10.896	0.359		130	*1155.351	1098.944	54.670	
201		1901001	10.665	0.389		131	*1155.730	1102.052	54.700	
201	C C	1870954	23.326	0.439		132	*1143.102	1103.283	54.750	C007
201		1885423	17.568	0.369		133	*1148.885	1103.000	54.680	
201						-3	*1155.730	1102.052	54.700	
201	FS A	1934030	19.953	0.509		134	*1146.887	1105.030	54.820	FS01

**Repeat measurement**

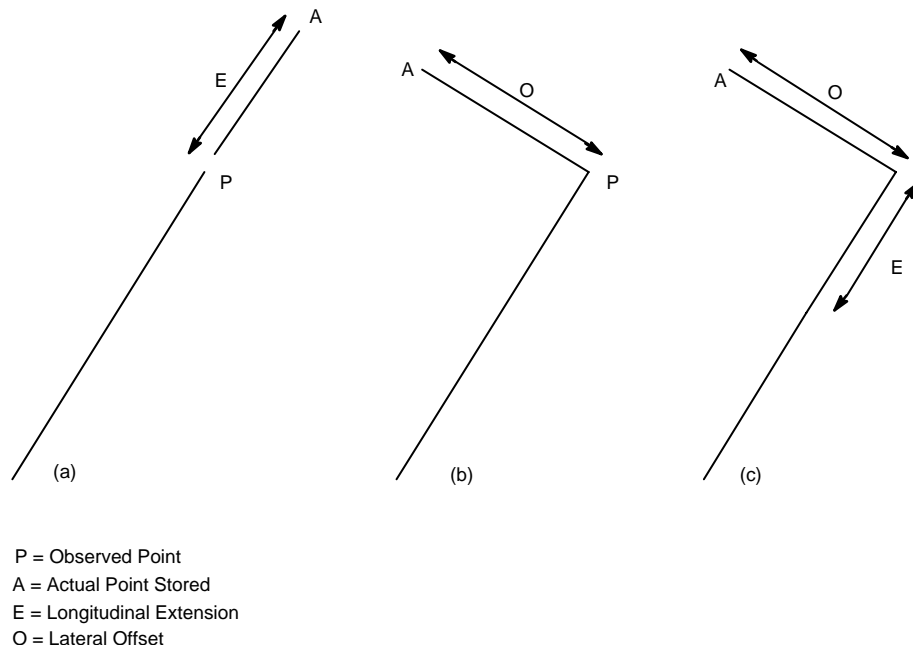
This is a special case of recalling an observation. If the measurement components and field 10 are all blank then the previous observation is recalled:-

201	WALA	1151609	10.371	-0.305		29	*1090.009	1102.783	55.380	WALA
201		1163453	10.192	-0.305		30	*1090.247	1102.959	55.380	
201		1193941	10.404	-0.305		31	*1090.221	1103.551	55.380	
201DISC		1180220	12.681	-0.235		32	*1087.963	1103.989	55.450	
201	GATE						*1087.963	1103.989	55.450	GATE
201DISC		1254952	13.693	-0.335		33	*1087.706	1106.030	55.350	
201	WALA						*1087.706	1106.030	55.350	WALA
202	C B	1343852	12.221	-0.715		34	*1089.982	1107.000	54.970	C006
201	WALA	1334159	12.476	-0.615		35	*1089.656	1106.976	55.070	WALA
201		1353525	12.955	-0.615		36	*1089.504	1107.594	55.070	

The technique of recalling observations only applies within a set of observations and cannot be used with previously processed data. The survey should note that it is the basic observation which is recalled and not the calculated point if an adjustment has been given on the observation being recalled.

**Adjusting an observation**

The surveyor has the facility to adjust the basic observation by coding a longitudinal extension and/or a lateral offset as shown in Figure 5 - 35.



**Figure 5 - 35 Adjusting an observation**

Sometimes the surveyor will want to store both the observed point (P) and the point defined by the extension (A), other times he will only want to store the extension. These two cases are illustrated below. A longitudinal extension is coded in field 8 and a lateral offset is coded in field 9 of an observation record.

When a quarry edge is being recorded the surveyor will want to store only the extended observation. Hence:-

```
201 E001 123404 20.096 1.955 3.0 * 12098.846 1076.933 57.640 E001
```

When a hedge is being recorded and the surveyor cannot position the target accurately he will probably store both the observed point and the extended observation. In such a case it is important to record a true level for an adjacent field point (ie P); the hedge (ie A) will often be given a null level (IGL indicator). To store both points the recall facility is used:-

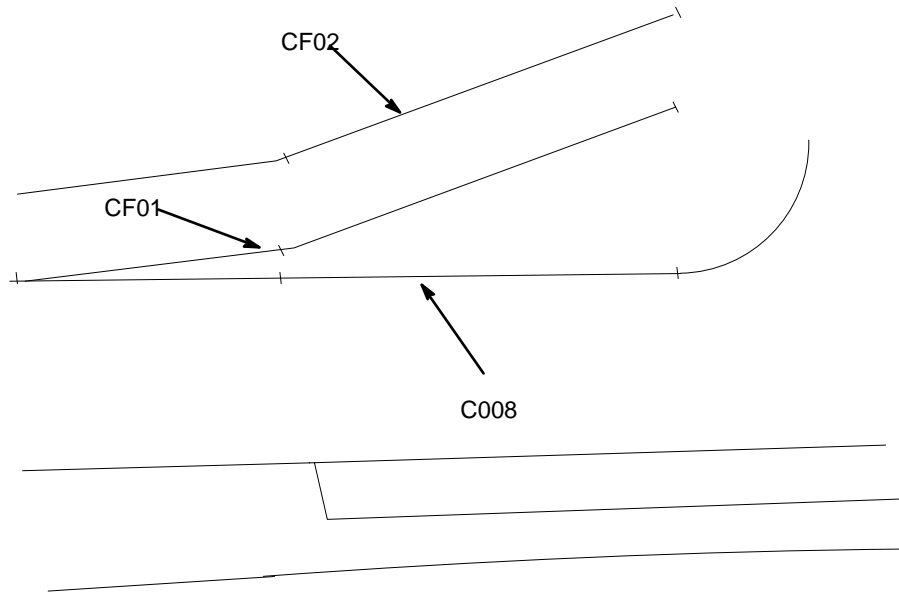
```
201 L001 123404 20.096 1.955 * 1098.996 1079.929 57.640 L001
2011GL H001 * 1098.846 1076.933 -999.000 H001
```

Several extension records can follow the initial observation record.

By default the level of the extended point is the same as that of the observed point. Null levels are assigned using the IGL indicator. If there is a known level difference between the two points the required level can be given to the extended point by specifying a level adjustment in field 7. Adjustments cannot be coded for observations which have an observation style of REAL; the adjustments should have been applied by the data collector in the field.

**Offset a point from a previous observation - OFFS, OFFL, OFFR**

As a string is being recorded it is possible to create other strings by specifying offsets from the original string. In Figure 5 - 36 string C008 has been recorded by observations and string CF01 and CF02 have been located by offsets relative to C008.



**Figure 5 - 36 Location by offset**

The offset to a point is coded in field 9. The point is offset at right angles to the direction of the previous link of the reference string (ie C008). If a point is offset from the first point on a reference string then the direction used for calculating the offset point is at right angles to the link between points 1 and 2 of the reference string.

The method of applying a level to the offset point is indicated by the contents of fields 1 and 7.

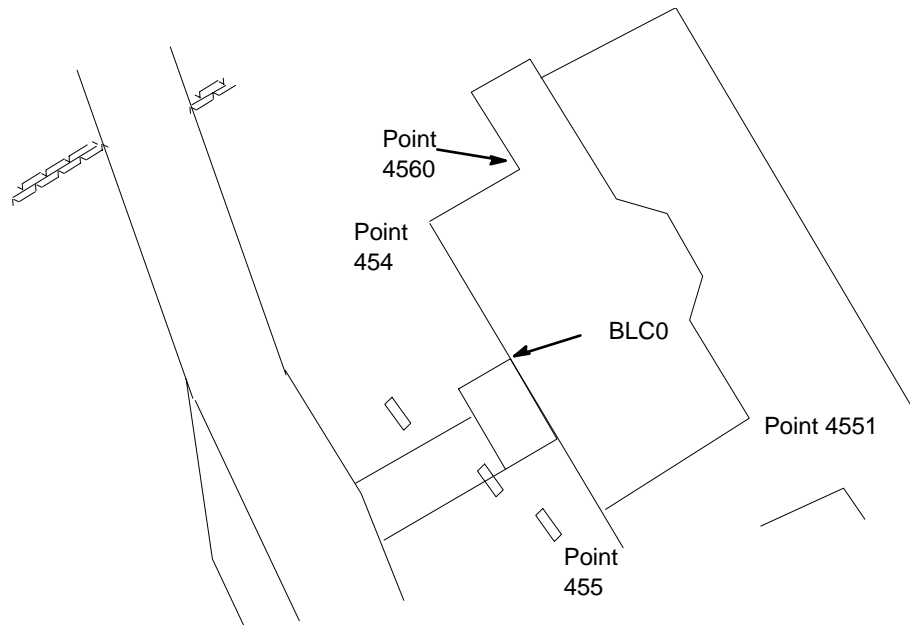
If field 1 contains OFFS the value in field 7 is a vertical adjustment to the level of the corresponding point on the reference string. If field 1 contains OFFR the absolute level of the offset point is coded in field 7. to allocate a null level to the offset code OFFL in field 1. The following data creates the strings shown in Figure 5 - 36.

201	C D	3162548	53.690	0.080		901	*1168.7411169.763	40.700	C008
201OFFS	CF01				0.1250.0		*1168.7411169.763	40.825	CF01
201OFFL	CF02				-2.0		*1170.0951171.236	-999.000	CF02
201	C D	3142313	46.232	0.170		902	*1174.3851164.575	40.790	C008
201OFFS	CF01				0.125-0.5		*1174.7241164.943	40.915	CF01
201OFFS	CF02				-2.5		*1176.0771166.415	-999.000	CF02
201	C D	3101746	36.303	0.260		903	*1182.0021157.566	40.880	C008
201OFFS	CF01				0.125-5.0		*1185.3881161.245	41.005	CF01
201OFFS	CF02				-7.2		*1186.8771162.864	-999.000	CF02
201	C D	3103320	33.594	0.280		904	*1184.5381156.601	40.900	C008
201	3132935 31.692	0.300				905	* 1186.978 1157.281	40.920	

**Taping from previous string links**

When a feature is being recorded by geometric observations some points on the feature may be obstructed from view. For example the surveyor may be able to make observations onto a building frontage but he cannot see the

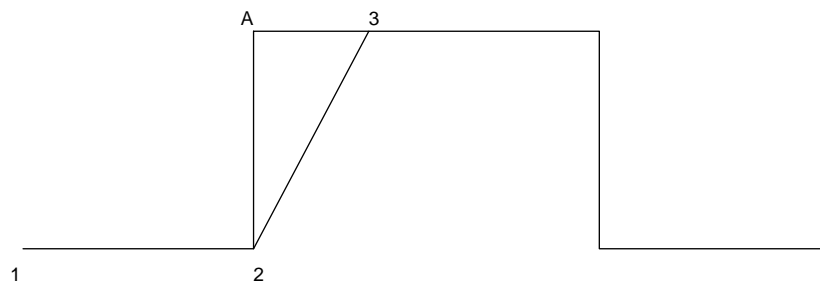
other sides of the building. In this case the remaining points of the building may be recorded by taping off the previous link.



**Figure 5 - 37 Taping from previous string links**

The longitudinal extension and the lateral offset relative to the previous link on the string are coded in field 5 and 6 respectively. The following indicators can be used in field 1:-

- TAPE the taped point is given the same level as the previous point.
- TAPL the taped point is given a null level.
- TAPR the taped point is given the absolute level coded in field 7.
- TAPN indicates the point is a construction point and is not to be stored. It is used as shown in Figure 5 - 38.



**Figure 5 - 38 Example of taping**

There are records in the data for points 1, 2, A(TAPN) and 3, only points 1, 2 and 3 are stored in the string.

The data to record the building shown in Figure 5 - 37:-

201	BLC	1995632	18.166	-0.804	454		*1101.179	1143.459	52.210	BLC0
201		2354229	9.480	-0.774	455		* 1105.961	1132.618	52.240	
201TAPE			-5.400	4551			* 1110.901	1134.797	52.240	
201TAPE			-4.400	4552			* 1109.126	1138.823	52.240	
201TAPN			0.800	4553			* 1109.858	1139.145	52.240	
201TAPE			-1.000	4554			* 1109.454	1140.060	52.240	
201TAPE		3.000		4555			* 1108.243	1142.805	52.240	
201TAPN		1.000		4556			* 1107.840	1143.720	52.240	
201TAPE			-0.800	4557			* 1107.108	1143.397	52.240	
201TAPE			5.800	4558			* 1104.767	1148.704	52.240	
201TAPE			-2.100	4559			* 1102.846	1147.857	52.240	
201TAPECLOS			-3.350		4560		*1104.198	1144.792	52.240	
201	W				455		* 1105.961	1132.618	52.240	W000

### Special observations for chain and offset surveys - TIE, PIV, LNE

The data specified for a normal chain and offset observation consists of the traverse distance and the offset distance as shown in the following diagram.

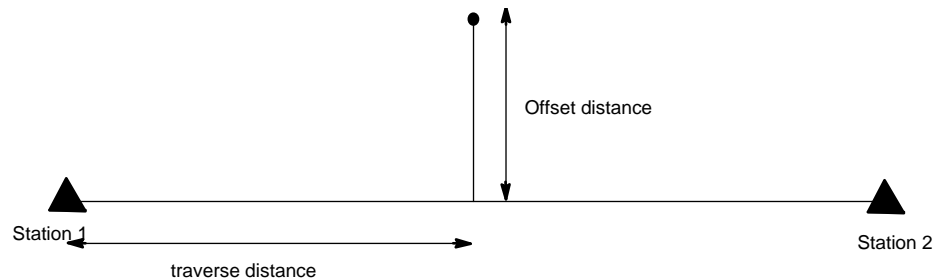


Figure 5 - 39 Example special observations for chain and offset surveys

To allow greater accuracy and flexibility further indicator codes, TIE for tie observations an PIV and LNE for Line of sight observations, can be used in chain and offset surveys. These codes must be given on pairs of observations which must follow each other without any other records between them.

### Tie observations

The accuracy of locating a point by normal offset distance decreases as the offset distance increases and to locate a point more accurately a pair of observations with the indicator TIE should be used.

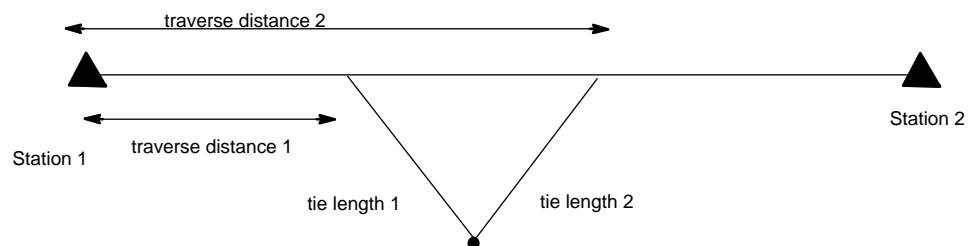


Figure 5 - 40 Example tie observations

Each record contains the indicator TIE in field 1 together with the appropriate traverse distance and tie length. The reduced level and feature identifier may be entered on either record. An example is shown below.

200STNZSTNCHOF								
201	F	25.0	1.4	*	1288.996	1536.036	-999.000	F000
201TIE		40.0	9.077	*	1274.823	1521.371	-999.000	
201TIE		50.0	9.819					

PIV/LNE Observations

Line of sight observations are taken where it is impractical to represent a feature almost normal to, and/or extending a large distance from the base-line. The method requires the surveyor to 'extend' the required feature until it intersects the base-line. By recording 'pivot' point A, together with the length of a feature and the intersection distance, the extents of the feature A and B can be located.

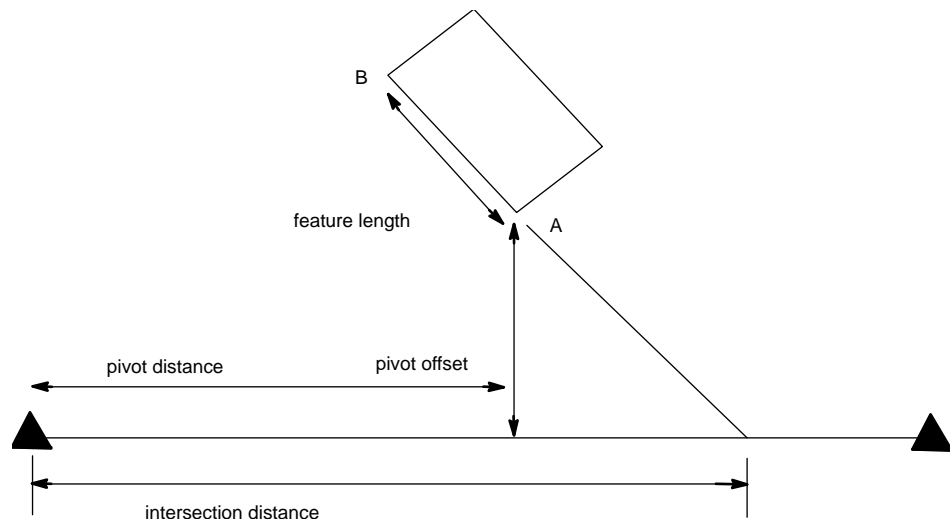


Figure 5 - 41 Example of PIV observation

The pivot point is recorded by a normal chain and offset observation (ie traverse and offset distance with the indicator entered as PIV). A second record contains the intersection distance and the feature length with the indicator set to LNE.

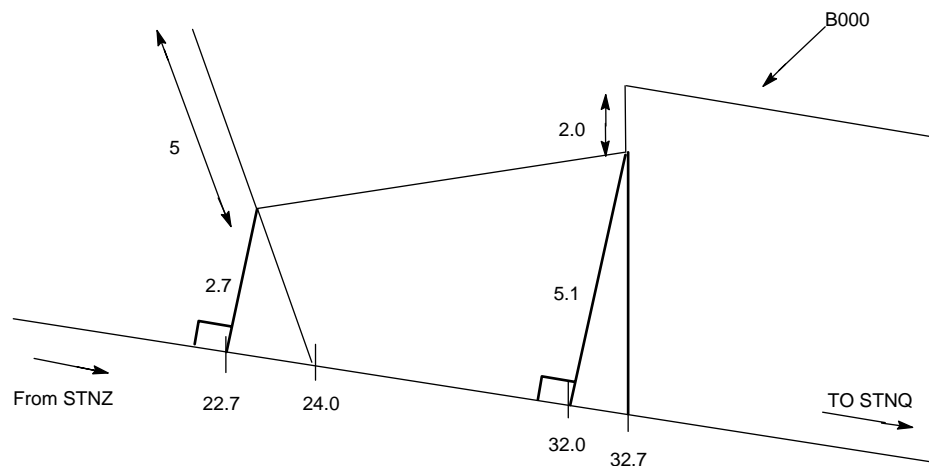


Figure 5 - 42 Example of LNE observation



200STNZSTNQCHOF							
201LNE	B	24	5	*	1298.684	1536.424	-999.000 B000
201PIV		22.7	-2.7	*	1293.685	1536.375	-999.000
201PIV		32	-5.1	*	1291.904	1526.937	-999.000
201LNE		32.7	2	*	1293.813	1526.341	-999.000
201		42.1	-7.9	*	1290.145	1516.605	-999.000

It is possible to store points A and B in the same string or in a different string by specifying the label for point A on the PIV record and the label for point B on the LNE record. If the points are to be stored within the same string then the order of the PIV and LNE records governs the order points A and B are stored eg if the PIV record is entered first then point A is stored first. If the first or both labels are blank then the first or both points are added to the previous string.

**Ignoring levels and Points - IGL, IGLL, IGN**

If the surveyor wants to ignore the calculated level for a point and assign a null level (-999.0) to the point he can use the following indicators which are coded in field 1:-

- IGL used to assign a null level to an individual point
- IGLL used to assign null levels to each point on a string. The is coded on the first observation for the string.

If the surveyor wants to determine the coordinates of a point but not to store the point in the survey he can code IGN in field 1 of the observation record. The coordinates will be shown in the printed output.

The following example shows the use of the indicators.

200000100009HDDL	0494015						
201	C0475155	56.189	1.691	*	1278.619	1506.483	75.390 C000
201	2325653	41.981	-0.505	*	1320.878	1594.987	73.194
201IGL	C0402844	56.689	1.673	*	1285.299	1503.567	-999.000 C001
201IGL	2424757	42.682	-0.505	*	1327.334	1591.573	-999.000
201	2334520	144.990	-0.519	*	1371.714	1684.585	73.180
201	C0475155	56.189	1.691	*	1278.619	1506.483	75.390 C002
201	2325653	41.981	-0.505	*	1320.878	1594.987	73.194
201IGLL	C0402844	56.689	1.673	*	1285.299	1503.567	-999.000 C003
201	2424757	42.682	-0.505	*	1327.334	1591.573	-999.000
201	2334520	144.990	-0.519	*	1371.714	1684.585	-999.000
201	C0475155	56.189	1.691	*	1278.619	1506.483	75.390 C004
201	2325653	41.981	-0.505	*	1320.878	1594.987	73.194
201	C0402844	56.689	1.673	*	1285.299	1503.567	75.372 C005
201IGN	2424757	42.682	-0.505	*	1327.334	1591.573	73.194
201	2334520	144.990	-0.519	*	1371.714	1684.585	73.180

**Specifying an absolute level**

Should the surveyor wish to override the observation reduced level then the real or absolute level may be included in field 7 with an associated indicator LEV in field 1.

**Appending points to existing strings - APP, APL, APLL**

If the surveyor wants to append points to strings which are already in the model he can code the label of the existing string in field 3 and one of the following indicators in field 1:-

- APP this will append the current point and subsequent points with blank labels to the existing string.
- APL as for APP but the point which contains the APL indicator will be given a null level.
- APLL as for APP but all points are given null levels. The indicator is coded on the first observation for the string.

◇ You should avoid using append for strings which are not already in the model.

The following example shows the use of the indicators.

2000002000VASD	0494015				1.586						
201APP	DDR1	0475155	0004804	56.197	0.681			*1278.618	1506.481	75.390	DDR1
201		23051433593212	144.795	0.922		*		1365.149	1687.820	73.192	
201		04028440004642	56.694	0.683		*		1285.299	1503.567	75.372	
201		24247573584919	42.691	1.213		*		1327.334	1591.573	73.194	
201		23345203593201	144.995	0.925		*		1371.714	1684.585	73.180	
201APL	DDR3	2325653	3584754	41.990	1.210			*1320.8781594.987		-999.000	DDR3
201		23051433593212	144.795	0.922		*		1365.149	1687.820	73.192	
201		04058440004642	56.694	0.683		*		1285.299	1503.567	75.372	
201		24247573584919	42.691	1.213		*		1327.334	1591.573	73.194	
201		23345203593201	144.995	0.925		*		1371.714	1684.585	73.180	
201APLL	DDR6	2305143	3593212	144.795	0.922			*1365.1491687.820		-999.000	DDR6
201		23051433593212	144.795	0.922		*		1365.149	1687.820	-999.000	
201		04028440004642	56.694	0.683		*		1285.299	1503.567	-999.000	
201		24247573584919	42.691	1.213		*		1327.334	1591.573	-999.000	
201		23345203593201	144.995	0.925		*		1371.714	1684.585	-999.000	
201	DDR2	0402844	0004642	56.694	0.683			*1285.2991503.567		75.372	DDR2
201	DDR1	2424757	3584919	42.691	1.213			*1327.3341591.573		73.194	DDR1

## Recording features in strings

### Curves

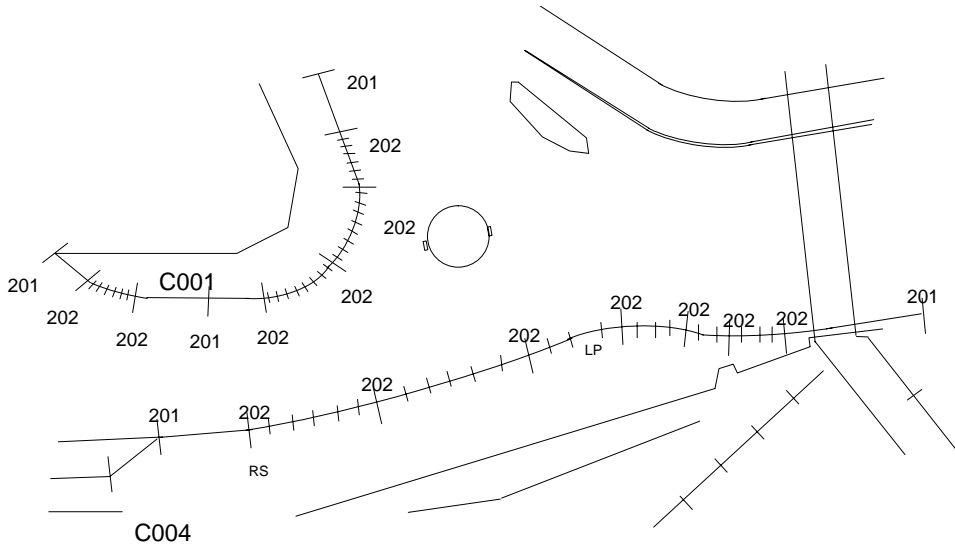
Many features will be either completely curved or a combination of curved and straight sections. Within a ground model the features must be defined accurately and points need to be closer together on a curve than on a straight. In the field the surveyor will generally record points at the same density regardless of whether they are on a straight or on a curve. He will also record which parts of the string are straight and which parts are curved - when the observations are processed MOSS will calculate extra points on the curves and store them in the model. Hence a curve can be recorded by observing the tangent points and one or more points on the curve. Levels on the extra points are determined by interpolating linearly between the levels of the adjacent observed points.

The curved and straight sections of a string are indicated by the use of minor options 201 and 202:-

- 201 indicates a point lying on a straight
- 202 indicates a point lying on a curve

No other information is needed to differentiate between points on curves and points on straights.

Strings C001 and C004 in Figure 5 - 43 both contain straight sections and curved sections. All the points in the stored strings are shown by pips. The points which were observed in the field are shown along with the minor option used to record them.



**Figure 5 - 43 Example of stored point display**

Any string link which contains a 201 observation is straight. A tangent point should be recorded by a 202 observation.

Two types of curve can be calculated. The curve type is determined by the indicator MOSS or SPLI:-

- MOSS generates a circular curve
- SPLI generates a spline curve

Spline curves need at least two points on the curve to be defined ie two 202 options. If there is no initial straight a natural spline is generated.

Circular curves need at least three points on the curve to be defined. If a circular curve is requested but only two points are given then a spline curve will be fitted.

The default curve type is MOSS. If the surveyor wants to change the default curve type to spline he can code this on a 189 option:-

```
189 , , SPLI
```

The required curve type can also be coded in field 2 of the first 202 option for a curve. A string can contain several curved sections separated by straights, discontinuities or discontinuous bearings. Curve types can be mixed within a string. If a curve type is given on a 202 option it is used only for the current curve - the type used for the next curve will be the default or the type set by a 189 option.

The number of extra points generated to define a curve depends on the curve fitting tolerance chord-to-arc tolerance. This is the chord to arc tolerance and the default value is 0.1. The default chord-to-arc tolerance is determined by the variable AHDETOLR in the parameter file. The default can be changed using the 189 option:-

```
189 , , , 0.025
```

The following data created strings C001 and C004 in the example above:-

201	C307515625.701	0.290		906	*	1191.261	1152.241	40.910	C001
202	SPLI 3024718	24.913	0.290	907	*	*1191.2721149.865	40.910		
						W606 SPLINE CURVE FITTING APPLIED.			
202	2985752 23.225	0.290		908	*	1192.499	1147.885	40.910	
201	2931748 19.894	0.300		909	*	1195.411	1145.214	40.920	
202	SPLI 2881948	17.708	0.300	910	*	*1197.4591143.417	40.920		
202	2791814 11.959	0.210		911	*	1203.284	1141.328	40.830	
202	2891843 7.673	0.120		912	*	1207.493	1143.184	40.740	
202	3174124 6.792	-0.020		913	*	1209.360	1146.317	40.600	
201	3393003 7.622	-0.120		914	*	1210.591	1148.882	40.500	
201	C3321145 9712	-0.120		915	*	1208.402	1149.754	40.500	c004
201	C309371155.554	0.050		937	*	1164.157	1164.808	40.670	C004
201	3060533 47.288	0.050		938	*	1170.674	1158.824	40.670	
201	3043355 47.705	0.240		9381	*	1169.866	1157.764	40.860	
201	2874537 30.026	0.370		939	*	1185.139	1143.565	40.990	
201	2831049 25.463	0.290		940	*	1189.729	1141.410	40.910	
202	SPLI 2764850	23.010	0.360	941	*	*1192.4571139.001	40.980		
						W606 SPLINE CURVE FITTING APPLIED.			
202	2560441 17.734	0.190		942	*	1199.824	1133.861	40.810	
202	2234233 14.998	0.190		943	*	1208.240	1129.466	40.810	
202	2050004 15.589	0.190		944	*	1212.784	1127.367	40.810	
202	1950259 18.396	0.230		945	*	1215.541	1124.383	40.850	
202	1903836 20.547	0.260		946	*	1217.163	1122.326	40.880	
202	1792030 25.799	0.380		947	*	1222.660	1118.092	41.000	
201	1705255 31.780	0.430		948	*	1228.772	1114.060	41.050	
201	PRS 2763328	23.596	0.460	9481	*	*1191.8961138.801	41.080		PRSO

### Discontinuities

Gaps often occur in linear features such as hedges and walls. The gaps can be recorded in the strings as discontinuities. This allows the linear feature to be defined by a single string instead of several different strings. Figure 5 - 44 shows two examples - the wall has a gap in it for the gate and the channel has a gap for the dropped kerb.

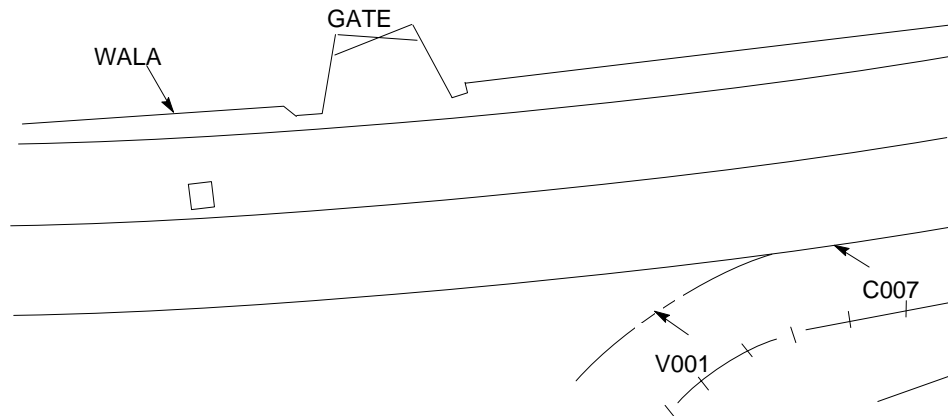


Figure 5 - 44 Examples of discontinuity

A gate is defined by two points. Each gate could be stored in a separate string but they can also be grouped together and stored in a single string - the gates being separated by discontinuities. This approach is just an extension of using point strings which are used to store points which have no continuity with adjacent points in the string.

When the surveyor inserts discontinuities into a string MOSS will store indicators in the model to indicate which points are at the starts and ends of the discontinuities. Hence MOSS knows where the discontinuities are when sections and drawings are being produced.

This method could be extended further to store all the buildings in a survey within a single string.

To indicate the start of a discontinuity the surveyor codes DISC in field 1 of the observation record. The following example shows how the features shown above were recorded. Subsequent points of the survey are shown to illustrate how the gates are grouped together into a single string.

201	WALA	1151609	10.371	-0.305		29	*	1090.0091102.783	55.380	WALA
201		1163453	10.192	-0.305	30	*	1090.247	1102.959	55.380	
201		1193941	10.404	-0.305	31	*	1090.221	1103.551	55.380	
201DISC		1180220	12.681	-0.235	32	*	1087.963	1103.989	55.450	
201	GATE							*1087.9631103.989	55.450	GATE
201DISC		1254952	13.693	-0.335	33	*	1087.706	1106.030	55.350	
201	WALA							*1087.7061106.030	55.350	WALA
202	C C	1704525	16.942	-1.385		42	*	1094.4991116.024	54.300	C007
								W605 MOSS CURVE FITTING APPLIED.		
202		1702927	15.853	-1.265	43	*	1094.783	1114.970	54.420	
202DISC		1702951	14.162	-1.155	44	*	1095.341	1113.374	54.530	
201	V							*1095.341	1113.374	V001
201DISC		1723657	12.177	-1.035	45	*	1096.422	1111.639	54.650	
202	C C					45	*	1096.4221111.639	54.650	C007
								W605 MOSS CURVE FITTING APPLIED.		
	----									
201		2550002	8.629	-0.644		408	*	1107.294	1129.766	52.370
201	GATE							*1107.2941129.766	52.370	GATE
201DISC		2444948	8.918	-0.714	409	*	1106.614	1131.194	52.300	
202	V C					408	*	1107.2941129.766	52.370	V00Q

**Bearings discontinuity**

These are situations in which the surveyor will want to record that a feature does not exhibit continuity of bearing throughout a point. Such points will occur at instantaneous changes of direction on a feature and would not be adequately represented on the model if stored as a normal point.

To indicate a bearing discontinuity at a point the surveyor codes DISB on field 1 of the 201 or 202 record which creates the point.

**Closing strings**

To store a feature such as a building in a model the last point on the string needs to be the same as the first point. The point does not need booking twice in the field - a string can be closed by coding CLOS in field 2 of the last observation for the string as shown in the example below.

201	BLO	2934036	3.818	-0.178		540	*	1142.533	1118.601	52.170	BL00
201		3595807	2.672	-0.098		541	*	1139.294	1120.339	52.250	
201TAPE				-2.000		543	*	1138.348	1118.577	52.250	
201TAPECLOS				-3.700		543	*	1141.608	1116.827	52.250	
992BL00											
LABEL	SUBREF	CONTENTS	NO. PTS	X -MIN	Y -MIN	X -MAX	Y -MAX	RECORD	LOC.		
BLOO		7703	5	1138	1116	1143	1121	144	271		
POINT		----	X-----	-----Y-----	-----Z-----						
		1	1142.533	1118.601	52.170						
		2	1139.294	1120.339	52.250						
		3	1138.348	1118.577	52.250						
		4	1141.608	1116.827	52.250						
		5	1142.533	1118.601	52.170						

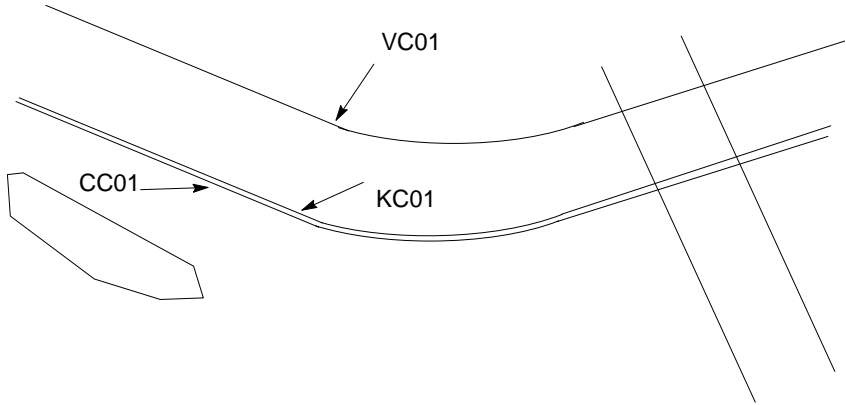
**Squaring strings**

The squaring facility allows the points defining a feature to be adjusted such that all the internal angles of the feature are right angles. This enhances the appearance of the feature on the drawings. No point will be adjusted by more than 1.0 metres from the observed position.

Squaring is invoked by coding SQUR in field 2 of the last observation for the string. Squaring and closing can be applied together by coding SQUC.

**Create a string parallel to another string**

The surveyor often has to record features which are parallel eg channel - kerb - back of footway. If there is also a constant level difference between the strings (or the level is not important) the surveyor can simply create a string relative to one he has already recorded in his data.



**Figure 5 - 45 Example create string parallel to another string**

The channel CC01 has been located by observations and the kerb KC01 and the back of footway VC01 have been defined by reference to CC01. Minor option 203 is used to create a string parallel to another string. The vertical offset is coded in field 4 and the horizontal offset in field 7 as shown below:-

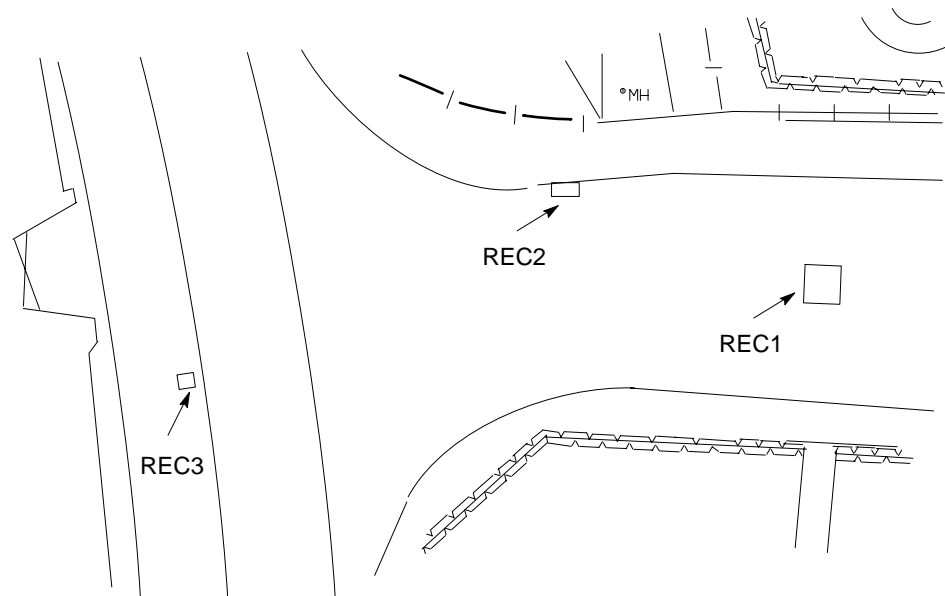
201	CC01	981035	4.494	-0.606		932	*1219.6041143.406	40.560	CC01
202	SPL1	1622048	9.588	0.070		933	*1220.5041134.817	40.690	
W606 SPLINE CURVE FITTING APPLIED.									
202		1670828	13.366	0.130		934	* 1221.658	1131.097	40.750
202		1644213	17.052	0.190		934	* 1224.077	1128.243	40.810
201		1545915	29.042	0.330		936	* 1234.310	1120.945	40.950
203CC01	KC01		0.125						-0.1
203CC01	VC01		0.175						-2.1

If field 4 is blank then null levels are assigned to the new string. The levels will be the same as the reference string if 0 is coded in field 4.

A summary of the data required for minor option 203 is given in a later section.

**Recording circular and rectangular features**

The surveyor will frequently need to record small features which are either circular or rectangular eg manholes. In the field the surveyor records the minimum information required to define the geometry of the feature and extra points are calculated and stored when the data is processed.



**Figure 5 - 46 Examples of rectangular features**

The rectangular manholes shown in the drawing are each defined by five points in the model - they were observed in the field by recording either three points or two points plus the width.

The same approach applies to recording circular features although many more points are calculated to define the feature. Hence the manholes are represented by typical MOSS strings - sufficient points are stored to model the features accurately. If it is important to have accurate levels for all points on the feature then there is no alternative to this method of storage.

If however, the surveyor is only interested in showing the location of the feature on plans there is an alternative - the features can be stored as objects in the model. This means that the information stored is reduced to that which defines the circle or the rectangle in plan. Hence MOSS stores two points and the width for a rectangle and the radius plus two points (at the ends of a diameter) for a circle. The features are drawn on plans using macrolines for circles and rectangles. The points stored retain the observed levels but levels are not defined for the complete feature. Objects are stored in 4D strings.

The surveyor would probably store all the circular objects in a single string and all the rectangular objects in another string. When objects are to be grouped together in a string MOSS will automatically introduce the necessary discontinuities.

Objects are recorded in the field using the same methods as for representing features by strings except that to create an object the indicator OBJ must be coded in field 2 of the first observation record for a feature.

### Methods for recording features in the field

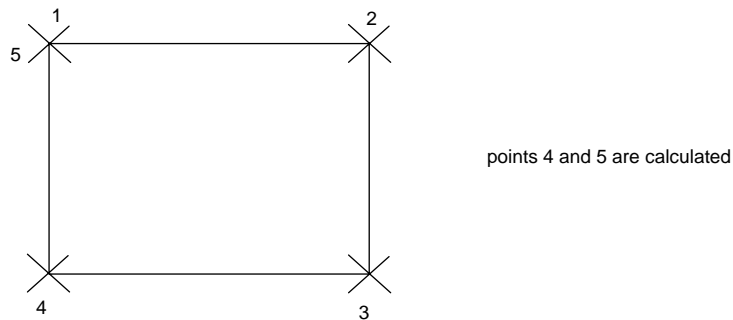
If an observation is to be used to generate a circular or rectangular feature an appropriate indicator must be coded in field 1, eg REPR.

The first two characters indicate whether the feature is circular or rectangular (CR or RE), the third character indicates how the feature is being recorded, the fourth character indicates how levels will be determined (R, S, L).

The indicator must be coded on each observation. If the feature is to be stored as an object then OBJ must be coded in field 2 of the first observation. Real levels are coded in field 7.

**Rectangles**

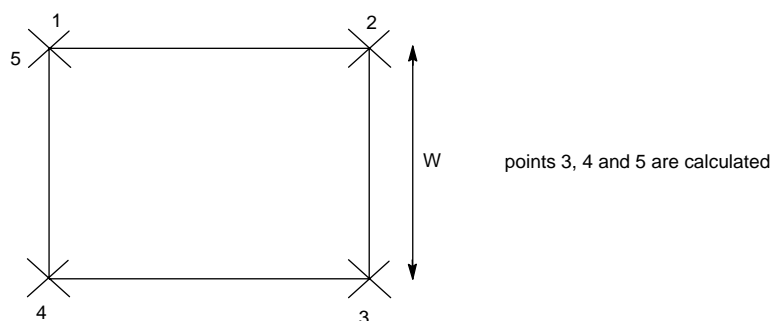
**REP\_** Record three consecutive points (1, 2 and 3)



**Figure 5 - 47 Example REP\_**

- REPR Will calculate levels for points 4 and 5 lying on the plane through the real levels given for points, 1, 2 and 3.
- REPS Will calculate levels for points 4 and 5 lying on the plane through the surveyed points 1, 2 and 3
- REPL Will assign null levels to all points.

**REM\_** Record two consecutive points and width (1, 2 and w).



**Figure 5 - 48 Example REM\_**

- REMR Will assign levels to points 3, 4 and 5 equal to the real levels given for points 2, 1, and 1 respectively.
- REMS Will assign levels to points 3, 4 and 5 equal to those surveyed for points 2, 1 and 1 respectively.



REML Will assign null levels to all points.

The width is coded in field 9 (negative to left, positive to right).

The manholes in the drawing above would be recorded as objects in the following way:-

201REMSOBJ	RECT	224057	9.302	0.815		6	*1097.9111090.936	56.500	RECT
201REMS	213708	10.181	0.815	-0.45	7	*	1097.898 1090.038	56.500	
201REMSOBJ	RECT	2662517	17.166	-0.405		63	*1116.7071103.944	55.280	
201REMS	2652137	16.223	-0.405	-0.99	64	*	1115.717 1104.019	55.280	
201REMSOBJ	RECT	2384200	9.954	-0.435		66	*1107.5121106.531	55.250	
201REMS	2404716	10.401	-0.435	-0.300	67	*	1108.093 1106.534	55.250	
201REMSOBJ	RECT	1172819	7.550	-0.145		69	*1092.8101102.304	55.540	
201REMS	1191632	7.078	-0.145	0.525	70	*	1093.331 1102.371	55.540	
999									
LABEL	SUBREF	CONTENTS	NO.PTS	X -MIN	Y -MIN	X -MAX	Y -MAX	RECORD	LOC.
RECT	RECT	7704	8	1092	1090	1117	1107	213	1
POINT	-----X-----			-----Y-----		-----Z-----		-----C-----	
1	1097.898	1090.038		56.500		0.450			
2	1097.911	1090.936		56.500		0.450			
---- DISCONTINUITY ----									
3	1115.717	1104.019		55.280		0.990			
4	1116.707	1103.944		55.280		0.990			
---- DISCONTINUITY ----									
5	1108.093	1106.534		55.250		0.300			
6	1107.512	1106.531		55.250		0.300			
---- DISCONTINUITY ----									
7	1092.810	1102.304		55.540		0.525			
8	1093.331	1102.371		55.540		0.525			

The manholes could be recorded as conventional strings using the following data:-

201REMS	REC	2662517	17.166	-0.405		63	*1116.7071103.944	55.280	REC1
201REMS	2652137	16.223	-0.405	-0.9964		*	1115.717 1104.019	55.280	
201REMS	RECT	2384200	9.954	-0.435		66	*1107.5121106.531	55.250	REC2
201REMS	2404716	10.401	-0.435	-0.30067		*	1108.093~ 1106.534	55.250	
201REMS	REC	1172819	7.550	-0.145		69	*1092.8101102.304	55.540	REC3
201REMS	1191632	7.078	-0.145	0.52570		*	1093.331 1102.371	55.540	
992REC1									
LABEL	SUBREF	CONTENTS	NO.PTS	X -MIN	Y -MIN	X -MAX	Y -MAX	RECORD	LOC.
BE1		7703	5	1115	1102	1117	1105	149	349
POINT	-----X-----			-----Y-----		-----Z-----			
1	1116.707	1103.944		55.280					
2	1115.717	1104.019		55.280					
3	1115.642	1103.032		55.280					
4	1116.632	1102.957		55.280					
5	1116.707	1103.944		55.280					

## Circles

CRC\_ Record the circle centre and the radius.

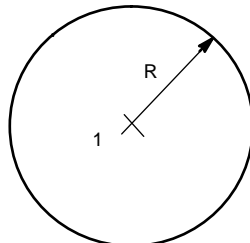
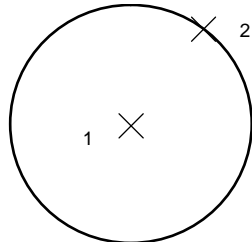


Figure 5 - 49 Example circle centre and radius

CRCR Will assign all levels on the generated string to be the same real level as that given for the centre.

- CRCS Will assign all levels on the generated string to be the same surveyed level as that given for the centre.
- CRCL Will assign null levels to all points. The radius is coded in field 9.

CR2\_ Record the centre of the circle and a point on its circumference.

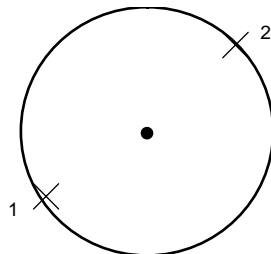


Both observations must have the indicator CR2\_ coded.

**Figure 5 - 50 Example circle centre and point on circumference**

- CR2R Will assign all levels on the generated string to be the same real level as that given for the second observed point (ie the point on the circumference).
- CR2S Will assign all levels on the generated string to be the same surveyed level as that given for the second observed point.
- CR2L Will assign null levels to all points.

CRD\_ Record points at both ends of a diameter of the circle.

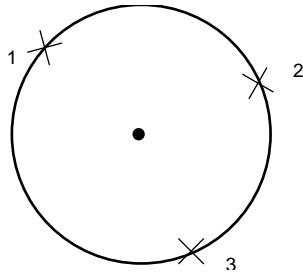


Both observations must have the indicator CRD\_ coded.

**Figure 5 - 51 Example circle both ends of diameter**

- CRDR Will assign levels interpolated between the real levels given for the two observed points.
- CRDS Will assign levels interpolated between the surveyed levels reduced from the two observed points.
- CRDL Will assign null levels to all points.

CR3\_ Record three points on the circle.



All 3 observations must have the indicator CR3 coded.

Figure 5 - 52 Example three points on circumference

CR3R Will assign levels generated from the plane through the real levels given for the three observed points

CR3S Will assign levels generated from the plane through the surveyed levels given for reduced from the three observed points.

CR3L Will assign null levels to all points.

The following example shows the recording of circular features. They are stored as objects in the string CIRC:-

```

201CRCSOBJ CIRC 2384200 9.954 -0.436 0.3 *1107.5121106.531 55.249 CIRC
201CR2SOBJ CIRC 2384200 9.954 -0.436 *1107.5121106.531 55.249
201CR2S 2404716 10.401 -0.435 * 1108.093 1106.534 55.250
201CRDSOBJ CIRC 1172819 7.550 0.145 *1092.8101102.304 55.830
201CRDS 1191632 7.078 -0.145 * 1093.331 1102.371 55.540
201CR3SOBJ CIRC 224057 9.302 0.816 *1097.9111090.936 56.501
201CR3S 213708 10.181 0.815 * 1097.898 1090.038 56.500
201CR3S 190651 10.104 0.816 * 1098.348 1090.032 56.501

992CIRC
LABEL SUBREF CONTENTS NO.PTS X -MIN Y -MIN X -MAX Y -MAX RECORD LOC.
CIRC CIRC 7704 8 1092 1090 1109 1107 215 1
POINT -----X----- -----Y----- -----Z----- -----C-----
1 1107.512 1106.831 55.249 0.300
2 1107.512 1106.231 55.249 0.300
3 ---- DISCONTINUITY ----
4 1108.093 1106.534 55.25 0.581
5 1106.931 1106.528 55.250 0.581
6 ---- DISCONTINUITY ----
7 1092.810 1102.304 55.540 0.263
8 1093.331 1102.371 55.250 0.263
9 ---- DISCONTINUITY ----
10 1097.911 1090.936 56.501 0.502
11 1098.348 1090.032 56.501 0.502
    
```

Drawing of recorded circular and rectangular features

Features which are fully defined as strings may be drawn out similarly to other feature strings but those which are stored within object strings require special treatment.

Rectangular objects are stored in 4D strings as pairs of points separated by discontinuities. The two points locate the base of the rectangle and the width is recorded in the fourth dimension. The width is always positive as the rectangle will always be drawn out to the right of the baseline.

Circular objects are also stored in 4D strings as pairs of points separated by discontinuities. For circles the two points locate the diameter of the circle and the fourth dimension defines the radius of the circle.

Note that all information is held in model units.

If the strings (both rectangular objects and circular) are not drawn with special interpretation then they will appear as straight lines between the defining points. However they may be correctly represented by the use of scaled macro lines (option 810 in DRAW).

Two macro line definitions are provided with the system:-

OBJRECT - Interprets rectangle object strings.

OBJCIRCL - Interprets circular object strings containing 28 defining points.

Either of these macros may be modified by the user if necessary.

The following data illustrates the use of the macros for the above examples.

```
DRAW,GROUND MODEL
.
.
.
.
810,MACR,OBJRECT,4,-1,7=500
826,RECT
810,MACR,OBJCIRCL,, -1
826,CIRC
```

### The points string

A points string can be created by the surveyor. This is a string which contains every point in the survey. It is a 4D string and the fourth dimension contains the point number as allocated by the surveyor (see section on coding point numbers). Hence the surveyor can record the survey simply as a series of points in the field and then form the strings later in the office using field sketches and the interactive editor.

The label of the points string is coded in field 3 of the 189 option and the string stored in the same model and the stations string. In the example below a points string named PSTR will be created and it will be stored in the second model. Note that a label must be given on the first observation record even if labels are not to be stored in the field.

```
189,,,PSTR
200,STN2,STN1,HDL D,2794215
201,,,C A,183701,20.215,1.755,,,,1
```

The recommended approach is to code string labels in the field as far as is practical. However for a survey where string labels are being coded in the field a points string can still be created and stored in the second model.

### Macro SURVDRAW

The string labels recorded in the data will conform to a predetermined labelling convention. This labelling convention will have been designed to

ensure that features are shown on the survey drawings by appropriate line styles or symbols eg dashed lines, tree symbols.

The line styles and symbols are created using major option MACRO and are stored in MOSS - they are known as macrolines and macrosymbols. A set of macrolines and macrosymbols for survey drawings is supplied with the MOSS system. The surveyor will probably create his own macrolines and macrosymbols to complement those supplied.

A string can be drawn using any macrosymbol. When major option DRAW is used to generate a survey drawing it must be told which macroline or macrosymbol to use for each string (except for strings using the default convention described in section 'String Labels'). This is the function of the SURVDRAW macro - for each label in the labelling convention it invokes the required macroline or macrosymbol. The simplest use of SURVDRAW is shown below.

```
DRAW,ST PETERS CLOSE  
900 ,SURVDRAW  
SC=500  
999
```

Chapter 3 describes the parameters required by SURVDRAW for controlling the drawing layout etc.

If the surveyor extends the labelling convention by creating his own macrolines and macrosymbols then the changes will need to be incorporated into the SURVDRAW macro.

## Major option SURVEY

Major option SURVEY provides a set of minor options for processing field survey information which is stored as a digital model for subsequent plotting as survey drawings. The stored data may additionally be analysed by any of the options in the MOSS system.

The minor options provide are :-

180	Storage of stations
189	Survey constants record
190	Theodolite constants record
200	Instrument set up record
201	Observation - point on a straight
202	Observation - point on a curve
203	Offset strings

### Data preparation

Major option SURVEY

Model 1 Model to contain survey information.

Model 2 Model containing the stations string and points string if different from model 1.

**Global minor options**

The global options 000, 017, 018, 900 and 999 may be used in SURVEY.

If there are any errors in the survey data the total information is processed as normal, as far as logically possible, indicating all the errors that occur but no strings are stored. All errors should be corrected prior to rerunning the data.

## Minor option 000    Insert a comment line

This minor option allows alphanumeric comments to be inserted into the input data to the system. The text will be printed and no further action taken. The use of comments allows the computer output to document the survey and include any field notes required by the surveyor.

### **Input**

Minor option 000 or blank

Fields 1-10    Alphanumeric text.

## Minor option 017 Define system parameters

### Input

#### Minor option 017

Field 1	Angular measure units (Input).
	DMS Degrees minutes and seconds - sexagesimal notation.
	DEGR Degrees and decimal - centesimal notation.
	GRAD Grads
	RADI Radians
	NORM Mixture of sexagesimal and centesimal notation.
	QUAD Quadrant bearings.
Field 2	Angular measure units (Output).
	DMS, DEGR, GRAD, RADI, NORM, QUAD as above.
Field 3	Survey station string label, default PSSA.

## Minor option 180 Add, amend or delete station

Adds, amends or deletes a station from a stations string.

### Input

#### Minor option 180

- \* Field 3 Station name.
- Field 4 If the station is to be deleted code -1.0.
- \* Field 5,6 Coordinates of station.
- Field 7 Level of station.

If station details are to be amended, specify the station name and new values for the coordinates and/or level - whichever needs modifying.

### Example

To define the name and position of a borehole

```
180,3=PBH1,,25833.5,17895.9,57.335
```

## Minor option 189 Survey constants record

Minor option 189 may be used to alter the values of various constants. On exit from the major option the values will revert to the default values. If this record is omitted then the default values are those set in the parameter file. There can be only one minor option 189 record in any run of the major option.



**Input data****Minor option 189**

- Field 1 The SURVEY major option which was available in earlier versions of MOSS (ie Version 6.3) may be invoked by coding 'OLD' in this field.
- Field 2 The default curve fitting style is MOSS. The style can be changed to spline by coding 'SPLI' in this field.  
All curves will use this curve fitting style unless the other style is specifically coded for the individual curve.
- Field 3 If a 'Point String' for the whole survey is required then code its label.  
If this field is not coded a points string will not be created. If the string already exists the observed points will be added to it.
- Field 4 If curved elements are being observed the chord– to– arc tolerance for the addition of extra points may be defined.  
The value must lie between 0.001 and 0.25. The default value is The default chord–to–arc tolerance is determined by the variable AHDETOLR in the parameter file. 0.10.
- Fields 5, 6 and 7 hold the standard errors of the instrument for use in location of stations by resectioning or intersecting rays.
- Field 5 Angular error (Default = 3 seconds).
- Field 6 Distance error, constant part, in millimetres (Default = 5 mm). Code a value in the range 1.0 to 9.9
- Field 7 Distance error, proportional part, expressed in ppm (Default = 5 ppm). Code a value in the range 1.0 to 9.9.
- Field 8 The default value, assumed by the program, for the radius of the earth is  $6.370 \times 10^6$ .  
This value is used in the corrections for Sea Level and Curvature/ Refraction. If this value is to be changed code the mantissa as a decimal number eg 6.370. The exponent  $10^6$  will be automatically applied by the program. Therefore the value used for the radius of the earth will be 6370000.
- Field 9 Code the value of the curvature/refraction coefficient if different from the default value of 0.071.

**Minor option 190 Theodolite and Traversing constants record**

This record is used to alter the preset values of the theodolite constants, the vertical angle datum and the direction of the vertical circle graduation. It is also used for defining the method of traverse adjustment and the constants associated with the traverse adjustment method.

## Input

### Minor option 190

Field 1	Code NRCH if checks on the absolute errors encountered in the resection processing are to be ignored.
Field 2	Indicator for method of traverse adjustment (default BOWD) BOWD for Bowditch (compass) method of adjustment. UNAL for unaltered bearings (Crandall's) method of adjustment. BIRD for Bird's method of adjustment.
Field 3	INCR if the vertical angle increases to zenith. DECR if the vertical angle decreases to zenith (default).
Field 4	Vertical angle datum (default 900000 DMS, 100 grad).
Field 5	$K^1$ (preset 100.0).
Field 6	$K_2$ (preset 0.0).
Field 7	Z Constant for Bird's method of adjustment. (default 0.005)
Field 8	F Constant for Bird's method of adjustment. (Default 5 parts per million )
Field 9	Permissible linear closing errors. (1 in 10,000 expressed as 10000.0) (Default value 10000.0)

## Minor option 200 Instrument set up record

This record defines the station on which the observations are based and also the reference or backsight station, the style of observation and the horizontal angle datum value. The collimation level may also be specified. For a traverse or resectioning only the instrument station, style of observation and correction factors should be specified.

## Input

### Minor option 200

- \* Field 1 Instrument station
  - \* Field 2 Reference station
  - \* Field 3 Style of observation
- Total Station equipment** - Define the components which along with the horizontal angle complete the geometry of the observation, eg HDVA, SDVA, HDVT, HDLD, VAHD, VTHD etc where :-
- HD = Horizontal Distance  
SD = Slope Distance  
VA = Vertical Angle  
VT = Vertical Tangent  
LD = Level Difference
- Chain and Offset** - CHOF

- 3-Stadia Tacheometry - STAD**
- 3-Stadia with Height Factor - STAK**
- Real Coordinates - REAL**
- Borehole logging - BORE**

◇ *This field must be entered on the first observation set up record but thereafter is optional unless the style of observation is changed.*

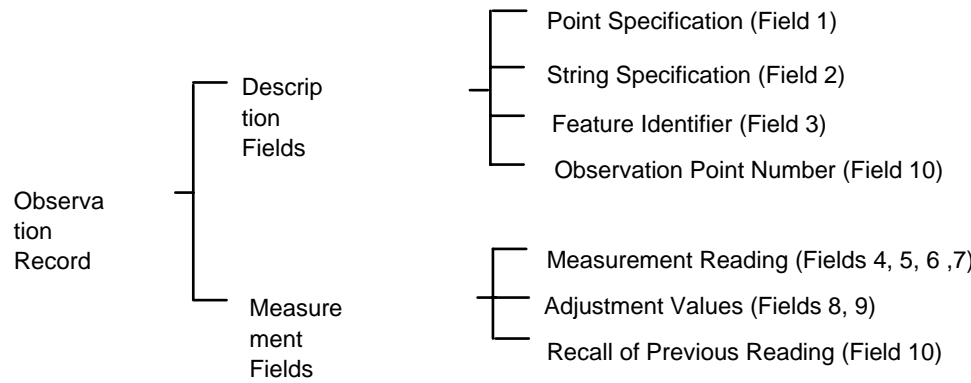
- Field 4 Horizontal angle datum.
- Field 5 Level component to establish collimation from the reference station (optional).
- Field 7 Establishment of Collimation Level. Height of telescope above the instrument station.  
The collimation level may also be established from the reference station in which case this field may contain a target height. If the instrument and target height are to be set equal then field 7 may be left blank.
- Field 8 Code 1.0 to invoke the curvature correction.
- Field 9 Code the elevation to be used for sea level correction.
- Field 10 Scale factor to be applied to distances. This is optional and will apply to following observations until changed. Default value is 1.0.  
If a scale factor is applied then sea level correction is made first.

◇ *If this field is coded then field 9 must also be coded.*

**Minor option 201/202 Observation point on straight/curve**

Observations are coded appropriate to the surveying instrument being used and the method of survey adopted. Each observation is analysed and the reduced coordinates stored in a model according to various indicators as set by the user.

Several components make up an observation record:-



There is no difference between the contents of options 201 and 202. 201 is used for points on straights and 202 is used for points on curves.

See earlier section.

**Minor option 201 or 202**

Field 1      Leave blank or code one of the following indicators:-

IGN, IGL, IGLL  
Used to prevent an observation being stored in the model (IGN) or to assign null levels to points.  
See section on ignoring levels and points.

LEV  
Associate the value defined in field 7 as an absolute level.

APP, APL, APLL  
Used when making an observation to a point which is the first of several points to be added to a previously stored string. APL will ignore the level for this point, APLL will ignore all levels subsequently appended to this string.  
See section on specifying an absolute level.

DISC, DISB  
Insert a discontinuity into the currently observed string at this point.  
DISC will indicate a break in the string whilst DISB will indicate a break in the direction of the string  
See sections discontinuities and bearing discontinuity.

TAPE, TAPL, TAPN, TAPR  
Locate a point by taped measurements relative to the previous observed link.  
Various alternatives exist for the definition of the level.  
See taping from previous string links section.

OFFS, OFFL, OFFR  
Offsetting of features. Points may be generated by offsetting from links defined by other observations. A surveyed level (OFFS), a null level (OFFL), or a real level (OFFR) can be assigned.  
See offset from a previous observation section.

TIE, PIV, LINE  
These indicators are used only with Chain and Offset Surveys to record tie observations and line of sight observations.

CHE  
Used when making a check observation to an existing station.

FLY, FLYT  
A new station may be established by a single observation. It is a simple unchecked fix and is often established as a temporary station. (FLYT) for recording local details.

RESN

A new station may be established by observing from an unknown location on to three or more known stations using resection methods to determine the station's position.

**INTS**

A new station may be established by observing its position from several existing stations. Intersecting ray analysis then determines the station's position.

**TRAV**

A set of new stations may be established by the construction of a simple open traverse or a closed traverse with facilities for adjusting the traverse with varying fixed end conditions.

**REPR, REPS, REPL**

Record rectangular feature by 3 points assigning a real, surveyed, or null level.

**rREMR , REMS, REML**

Record rectangular feature by 2 points and the width.

**CRCR, CRCS, CRCL**

Record circular feature by centre and the radius.

**CR2R, CR2S, CR2L**

Record circular feature by centre and a point on the circumference.

**CRDR, CRDS, CRDL**

Record circular feature by 2 points on a diameter.

**CR3R, CR3S, CR3L**

Record circular feature by 3 points on circumference.

Field 2 Leave blank or code one of the following indicators:-

**MOSS, SPLI**

(Option 202 only.) Indicates whether a circular (MOSS) or a spline curve (SPLI) is required.

**CLOS**

Invokes the automatic closure of strings for features such as buildings or boundaries.

**SQUR, SQUC**

Invokes the squaring of strings. The Ordnance Survey method of squaring is adopted. The facility is invoked by coding SQUR against the final recorded point. Both Squaring and Closing may be applied using the indicator SQUC.

**OBJ**

Indicates that a circular or rectangular feature is to be stored in the model as an object.

Field 3 The label of string where the observation is to be stored or the name of the station being observed.

**Basic measurement**

Not completed if field 1 is TAPE, TAPL, TAPR, TAPN, or OFFS, OFFR, OFFL, or if a previous observation is being recalled.

Geometric:

- \* Field 4 Horizontal angle measured clockwise from the reference station.
- \* Field 5 First measurement component (usually distance component) as defined by field 3 of the 200 option.
- \* Field 6 Second measurement component (usually level component) as defined by field 3 of the 200 option.
- Field 7 Target height.
- Field 8 Azimuth bearing for traverse observation. This can be coded if field 1 contains TRAV. If coded then fields 3, 5 and 6 must be omitted

3-stadia:

- \* Field 4 Horizontal angle measured clockwise from the reference station.
- \* Field 5 Vertical angle or height factor.
- \* Field 6 First stadia reading (usually top).
- \* Field 7 Second stadia reading (usually middle).
- \* Field 8 Third stadia reading (usually bottom).

Chain and offset:

- Field 5 Traverse distance or intersection distance (LNE).
- Field 6 Offset (negative to the left, positive to the right) or feature length (LNE).
- Field 7 Reduced level. If blank a null level will be assigned.

Real:

- Field 5 First coordinate. (X or Y depending on coordinate system).
- Field 6 Second coordinate. (Y or X depending on coordinate system).
- Field 7 Level. If blank null level will be assigned.

**Adjusted measurement (geometric observations only)**

- Field 7 Adjusted target height.
- Field 8 Line of sight adjustment (forward positive, backwards negative).
- Field 9 Lateral adjustment (left negative, right positive).

**Taped measurements (for geometric, 3-stadia, real coordinate surveys)**

- Field 1 must be TAPE, TAPL, TAPN, TAPR. Basic measurement not supplied.
- Field 5 Longitudinal distance along the previous link. (forwards positive, backwards negative).

- Field 6 Lateral offset from the previous link (left negative, right positive).
- Field 7 Vertical adjustment to be applied to the level of the previous observation, or real level for TAPR.

**Offset measurements**

Field 1 must be OFFS, OFFL, or OFFR. Basic measurement not supplied.

- Field 7 Vertical adjustment to be applied (OFFS), or real level (OFFR).
- Field 9 Offset (left negative, right positive).

**Circular/rectangular features**

- Field 9 Width of rectangle or radius of circle.

**Recall previous measurement**

Basic measurement not supplied.

- Field 10 Point number of the observation to be recalled. Negative value specifies point by relative position.

**Specify point number for observation**

- Field 10 The point number to be allocated to the observation. If blank the number will be incremented from that of the previous observation.

## Minor option 203 Offset strings

Strings may be generated parallel to the surveyed features. Having surveyed a string the surveyor may create a second string offset from it by a constant amount both horizontally and vertically.

**Minor option 203**

- \* Field 1 Reference string from which offsets are to apply.
- \* Field 3 Label of string to be generated.
- Field 4 Vertical offset to be applied.  
If blank then null levels will be assigned to the generated string. If zero is coded then the levels of the reference string will be assigned.
- Field 7 Horizontal offset to be applied.

# Transformation

Major option SURVEY provides comprehensive facilities for establishing survey control stations. These stations can be used for the complementary SURVEY ground detail surveying options and other major options such as DIGIT, for establishing aerial survey control and for SETOUT, for locating convenient setting out stations.

Many of the station location features, (traversing, intersecting rays and resection) are now totally integrated into the standard SURVEY option. However the least squares transformation style is accommodated separately.

The transformation technique allows the correlation of previously recorded survey information with a new survey. It may be used to establish new coordinate values for existing survey control points. If survey stations are not shown on the old drawings distinct features may be selected as control points. The transformation option selects the most appropriate points to give a reliable correlation. These points can then be used as the control for digitising the complete drawing.

## Transformations

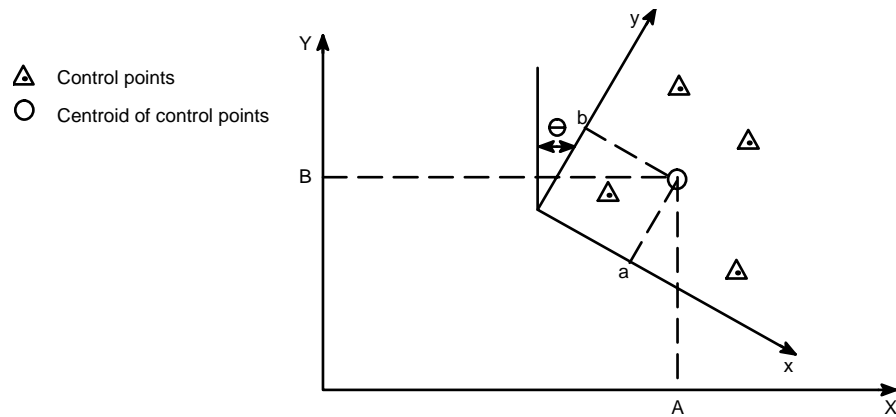
The facility produces a transformation from one orthogonal coordinate system to another. The control coordinates are derived using a least squares technique to minimise the error of the solution.

The analysis is usually required for transferring old survey information. The original survey control points may be shown on the plans and have coordinate values but as a result of time the locations may not be reliable. Additionally the coordinates may be given for a local grid and require locating in a new system. A further situation is that when working with old plans, the survey control points may not be available. In this situation it is necessary to construct an accurate grid over the area. Several distinct features should be selected as control points and their coordinates determined.

In both situations the new survey must locate the control points and provide new coordinates. The transformation facility permits a method for evaluating the survey stations and features for indicating the most reliable control points.

The control points are used to determine the transformation and the mathematical theory is identical to that as used in major option DIGIT. This option requires a minimum three control points and permits a maximum of one hundred points. The transformation is localised about the centroid of the system rather than any particular control point so that any errors in the control points themselves are uniformly distributed.





**Figure 5 - 53 Transformation old to new survey grid**

The transformation equations are:-

$$X = K_1 (x - a) - K_2 (y - b) + A$$

$$Y = K_1 (y - b) + K_2 (x - a) + B$$

where:

A and B are the X and Y coordinates of the centroid of the control points in the new system.

a and b are the x and y coordinates of the centroid of the control points in the old system.

$K_1$  is the cosine of the transformation angle \* the scale factor.

$K_2$  is the sine of the transformation angle \* the scale factor.

The adequacy of the transformation is assessed by comparing the errors of the transformed points in the directory of both the new axes with the standard errors for the transformation. Any points having an error greater than twice the standard error are suspect and indicated by a warning message. If any points have an error greater than twice the standard error are suspect and indicated by a warning message. If any points have an error greater than three times the standard error the transformation is considered invalid. The suspect point coordinates should be corrected or rejected and the complete block of data re-run.

In addition to assessing the magnitude of the errors compared to the standard error, the absolute magnitude of the errors should be considered with regard to the accuracy required for the transformed information. The coordinate errors are compared with a tolerance which is specified with the initial 199 minor option (default value of 1.0 metres) and if it is exceeded the transformation is considered invalid. The transformation information or tolerance must be reassessed before re-running the data.

Once a satisfactory transformation has been found the general (non-control) points are transformed and all points may be stored in a station string.

### Data preparation

Major option SURVEY

1st Model      Model containing the survey station string for both existing and new stations.

## Minor option 189      Survey constants record

This record must always be included for transformation and must always be the first following the major option record.

### Input

#### Minor option 189

Field 1      Code 'OLD' (this will invoke the earlier version of the SURVEY option).

## Minor option 199      Least squares transformation

Least squares transformation of coordinates between two orthogonal systems.

### Input

#### Minor option 199

Field 1      Existing station name (optional).

Field 3      New station name. If blank then the point is not stored after the transformation.

Field 4      Tolerance in residual coordinate errors, dx and dy for the transformed position of the block control points. Only specified on the first minor option.

Field 5,6,7      Point coordinates ( x, y and z) in the existing system. If these fields are entered then field 1 should be blank and vice-versa.

Field 8,9      Point coordinates in the new system. Only entered for the control points.

The option is used to enter both the transformation control points and general points for which transformed values are determined after satisfactory completion of the transformation. Both the control and the general points may be stored in the station string by specifying their new station name in field 3.

### Example

In the example four control points are specified for the transformation. Two of the existing points are stored in a station string and two are specified as input.

Seven points are identified with labels for storing as stations in the model and the remaining two points are simply printed with their transformed coordinates.

```

SURVEY NEW SURVEY TEST
189OLD T001 1919.0 1043.0 245.0
180 T004 8984.0 4567.0 229.0
199T001 STN1 1600.0 7700.0
199 STN2 162.0 4568.0 257.0 1600.0 7750.0
199 STN3 7238.0 8066.0 231.0 1700.0 7750.0
199T004 STN4 1700.0 7700.0
199 STN5 7840.0 2190.0 241.0
199 STN6 6933.0 4747.0 233.0
199 STN7 8385.0 2160.0 251.0
199 2797.0 6639.0
199 3551.0 7131.0

LEAST SQUARES TRANSFORMATION - CONTROL POINTS
---OLD SYSTEM COORD--- --NEW SYSTEM COORDS--- --TRANSFORMED COORDS-- -----ERRORS-----
      XX      YY      X      Y      X Y      DX      DY
      1919.000 1043.000 1600.000 7700.000 1599.992 7700.043 0.00835 0.04265
      162.000 4568.000 1600.000 7750.000 1599.914 7749.992 0.08590 0.00832
      7238.000 8066.000 1700.000 7750.000 1700.017 7749.017 0.01724 0.18158
ORIGIN 0.0 0.0 1572.312 7699.018

STANDARD ERROR OF TRANSFORMATION 0.06752 0.13729

ROTATION ANGLE = 333 35 43.7
SCALE FACTOR IS = 0.012682

THE TRANSFORMATION IS :-
      X = ( 0.011359 * (XX- 4575.750) - (-0.005640 * (YY- 4559.250)) ) + 1650.000
      Y = ( 0.011359 * (YY- 4559.250) + (-0.005640 * (XX- 4575.750)) ) + 7725.000

WHERE (XX,YY) ARE THE OLD SYSTEM COORDS
      (X,Y) ARE THE NEW SYSTEM COORDS

LEAST SQUARES TRANSFORMATION - GENERAL POINTS
---OLD SYSTEM COORD--- -----TRANSFORMED COORDS----- STATION
      XX      YY      X      Y      Z
      1919.000 1043.000 1599.992 7700.043 245.000 STN1
      162.000 4568.000 1599.914 7749.914 257.000 STN2
      7238.000 8066.000 1700.017 7749.818 231.000 STN3
      8984.000 4560.000 1700.077 7700.147 229.000 STN4
      7840.000 2190.000 1673.716 7679.679 241.000 STN5
      6933.000 4747.000 1677.835 7713.838 233.000 STN6
      8385.000 2160.000 1679.738 7676.264 251.000 STN7
      2797.000 6639.000 1641.525 7758.655 -999.000
      3551.000 7131.000 1652.864 7759.991 -999.000

```

# Survey accuracy validation

Major option REPORT includes a minor option for assessing the accuracy of models prepared by major option DIGIT, IDIGIT, SURVEY or GENIO:

998 Evaluation of level and lateral differences

## Theory

### Types of error

Research into string model theory has identified the following sources of error:

- Gross errors
- Survey errors, implicit in the recording of data
- Quality of model errors, dependent on the nature and density of data and the retrieval techniques used.

Gross errors may be checked by plotting the model and then comparing it with the supporting plans. It also helps to contour and take wireline perspective views to highlight any major anomalies.

Survey and quality of model errors can be checked by resurveying test areas. By comparing data from the test areas with that already stored in the model, the magnitude of the combined errors can be obtained within specified confidence limits.

### Model sampling procedure

There are two requirements when obtaining data from the test area:

- To determine the vertical accuracy of the general ground coverage
- To determine the vertical and horizontal accuracy of known 3D features, eg, road channels, fence lines etc.

### General ground coverage

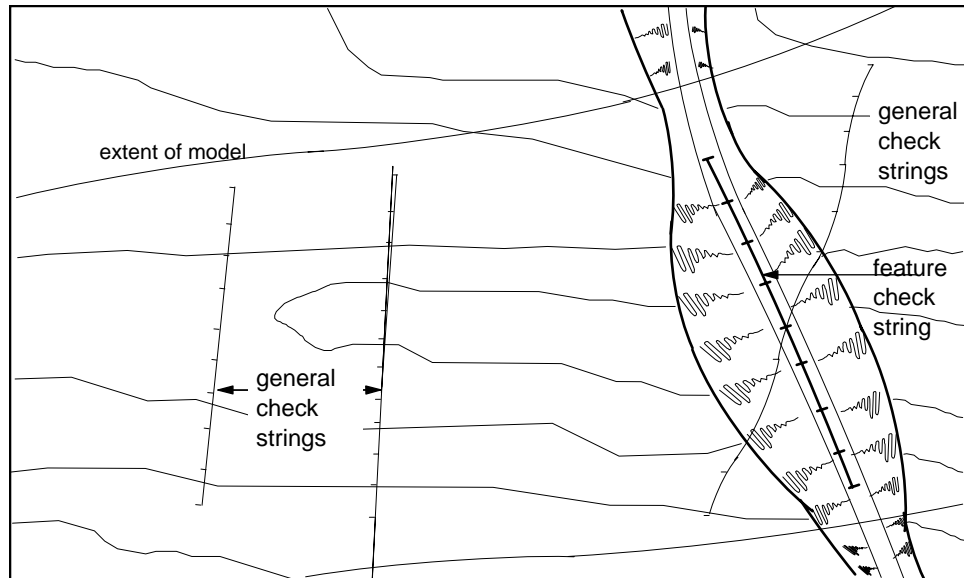
The accuracy of the general ground coverage data may be assessed by surveying a series of general check strings and comparing each of these with the equivalent long sections through the model.

In practice, for a highway scheme, the test areas should be every 0.5 to 1 kilometre along the length of the model, and at least 3 strings in each test area should be recorded across the width of the model. The newly-surveyed strings must record all angular changes of ground profile with points at an interval not exceeding 10 metres.

### Known features

At least one known feature should be identified and recorded in each test area, so that it can be compared directly to the corresponding stored string.

Resurveyed feature strings should have more points than the corresponding stored string created with the original chord to arc tolerance. A typical test site is shown in Figure 5 - 54.

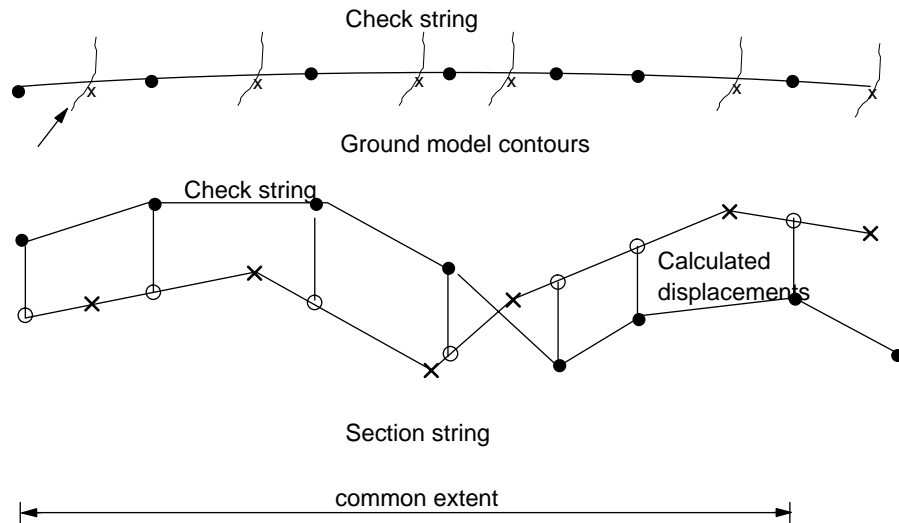


**Figure 5 - 54 Example test site**

### Evaluation technique

The technique for assessing the general ground coverage is to take long sections through the ground model along the check strings and to compare the vertical differences from each point on the surveyed string to the section string. The mean and standard deviation of these differences are determined and the size and extent of the errors are indicated by constructing confidence intervals about the mean error.

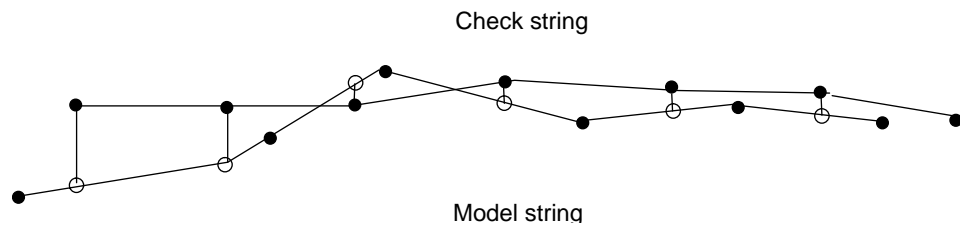
Figure 5 - 55 illustrates the comparison of the check and section strings.



**Figure 5 - 55 Example showing calculated vertical differences**

In the case of feature strings, the model string will not necessarily be directly superimposed on the check string in the horizontal plane and so the model string has to be projected laterally onto the check string to ensure chainage compatibility. The extent of this horizontal error is quantifiable in the same way as it is for the vertical differences and is expressed as a mean error with associated confidence intervals.

Figure 5 - 56 illustrates the projection of the model string onto the check (reference) string in the vertical plane, giving both the horizontal and vertical displacements at the points on the check string.



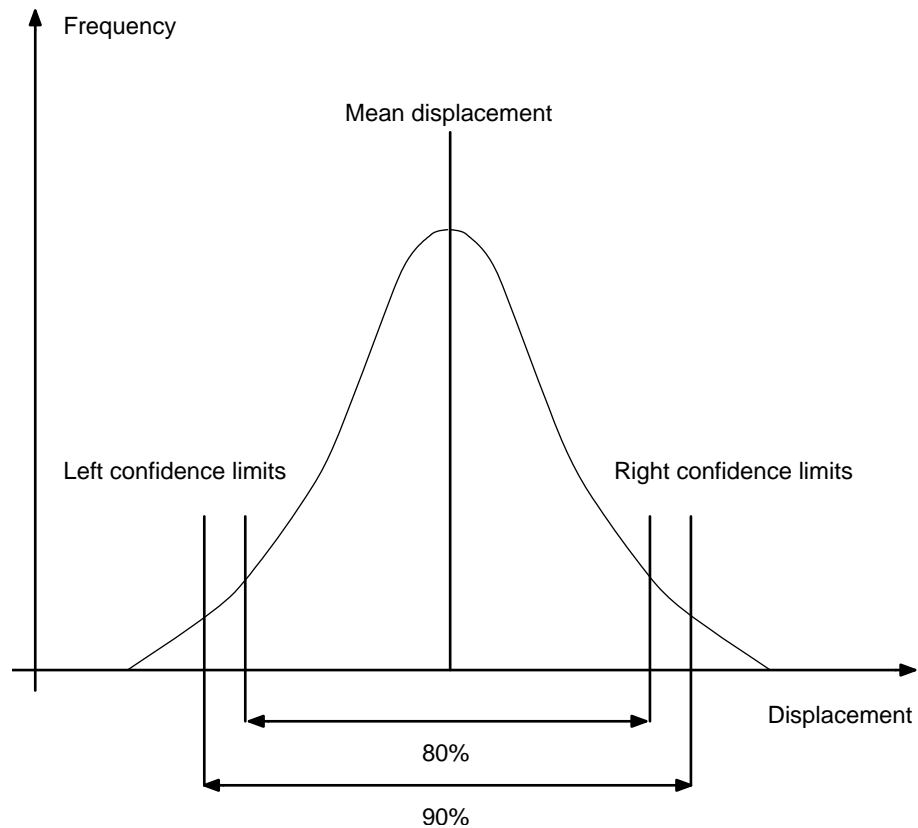
**Figure 5 - 56 Comparing model and check feature strings**

### Interpretation of results

The calculation of the individual and mean displacements by minor option 998 indicates the overall error inherent in taking the ground model as the representation of the ground surface, assuming that the validation survey represents the true ground surface.

As with any statistical analysis the mean displacement will rarely be zero, but provided it lies within a reasonable range the survey may be deemed acceptable. For this reason, a significance level may be specified which defines a confidence interval to express the validity of the results. A

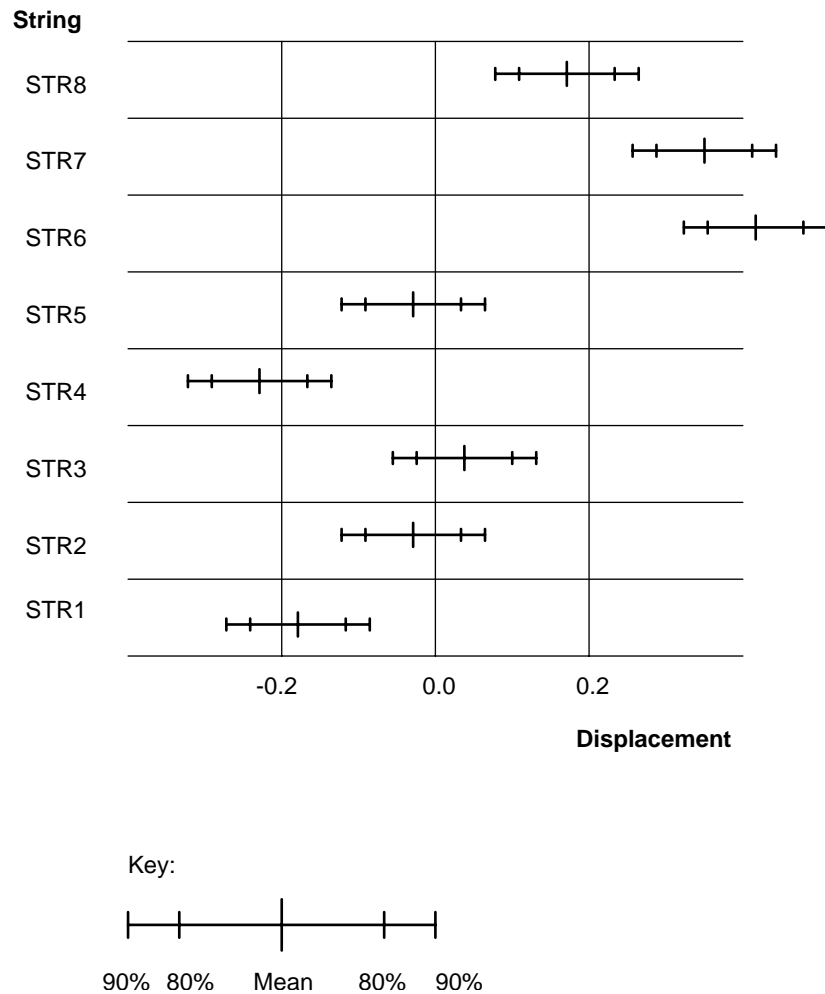
significance level of between 80% and 90% is suggested as a reasonable value to be used.



**Figure 5 - 57 Displacement results with confidence intervals**

As can be seen from Figure 5 - 57 the higher the significance level, the greater the number of results which are accepted as valid data.

All results should be checked to ensure that they lie within the tolerance used when carrying out the survey. A diagram such as that shown in Figure 5 - 58 can be used to determine whether the displacements output by minor option 998 are acceptable.



**Figure 5 - 58 Analysis of displacement errors**

A tolerance of 0.2m is used in the example.

The mean displacement for STR1 is within tolerance, although the confidence interval falls outside. This implies a constant negative shift in the results which could be caused by insufficient data being collected in a particular area.

STR2 and STR3 are acceptable as the confidence interval includes zero displacement and all the results are within tolerance.

STR4 is similar to STR1 except that the mean displacement is outside the tolerance range. Consequently, you may wish to survey further test sites in the same area to check the results.

STR5 is acceptable whereas STR6 and STR7 are completely out of range. A possible cause for this type of error is that a check string has been compared with the wrong model string, for example, a kerb string from the check survey has been compared with a channel string in the model.

STR8 is similar to STR1 except that a constant positive shift has occurred.



These diagrams should be prepared for assessing the vertical displacement of the general check strings, and both the vertical and lateral displacement of the feature strings.

## Models for REPORT

Major option REPORT

Model 1 Field surveyed strings model

Model 2 Complementary model. If omitted all strings assumed to reside in first model.

## Global minor options

Global options 000, 017, 900, and 999 may be used in this option. Strings with discontinuities cannot be used with this option.

## Minor option 998 Evaluation of level and lateral differences

This option compares a surveyed check string and the corresponding section string or feature string. It reports the vertical and lateral displacements, together with the mean displacement, standard deviation and the derived confidence intervals for specified significance levels.

**Translators note: Students 't' should not be translated**

Statistical tables (Student's 't' distribution) are incorporated within the option which permit confidence intervals to be determined for significance levels of 50.0, 80.0, 90.0, 95.0, 98.0 and 99.0. If the significance values are omitted only the displacements are produced.

Where check strings record general ground coverage their corresponding section strings should be determined by minor option 171 in SECTION which extracts an equivalent long section from the model. Feature check strings have a corresponding model feature string.

◇ *It is also possible to compare extracted model cross sections with the real sections set out and measured in the field, or indeed any pair of strings.*

The option compares the first three dimensions of the two strings. The check string is the reference string and the model string is effectively projected laterally onto this to remove any chainage distortion. This horizontal projection has no effect when comparing general check strings and their associated long sections, but is very important for feature strings or correlating pairs of cross section strings.

Invariably the pair of strings which are compared will not have consistent end points and only that part of the check string which is common to the two strings can be considered. The option will assume the start and finish of the common section to be the extents of the check (reference) string. If not, the start and end points must be specified.

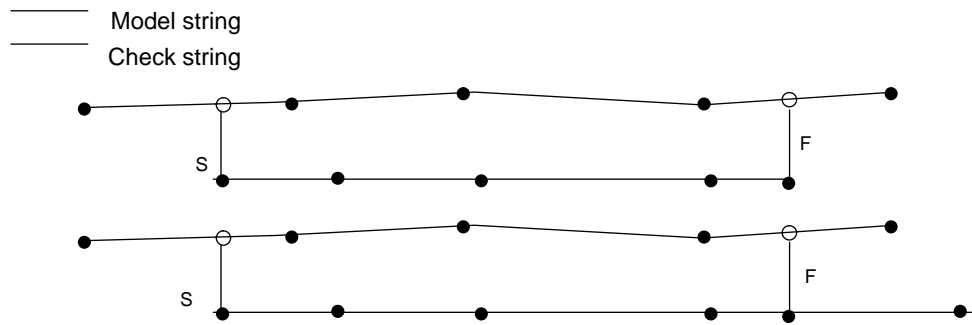


Figure 5 - 59 Vertical and lateral displacement between two strings

Input

Graphics

See major option REPORT.

Linemode

Minor option 998

- \* Field 1 Reference (check) string
- \* Field 2 Model string to be assessed.
- Field 5 & 6 SPRD start
- Field 7 Percentage significance level for vertical displacement.  
This value determines the confidence interval for which results are to be analysed (see 'Interpretation of results').
- Field 8 & 9 SPRD end
- Field 10 Percentage significance level for lateral displacement.  
This value determines the confidence interval for which results are to be analysed (see 'Interpretation of results').

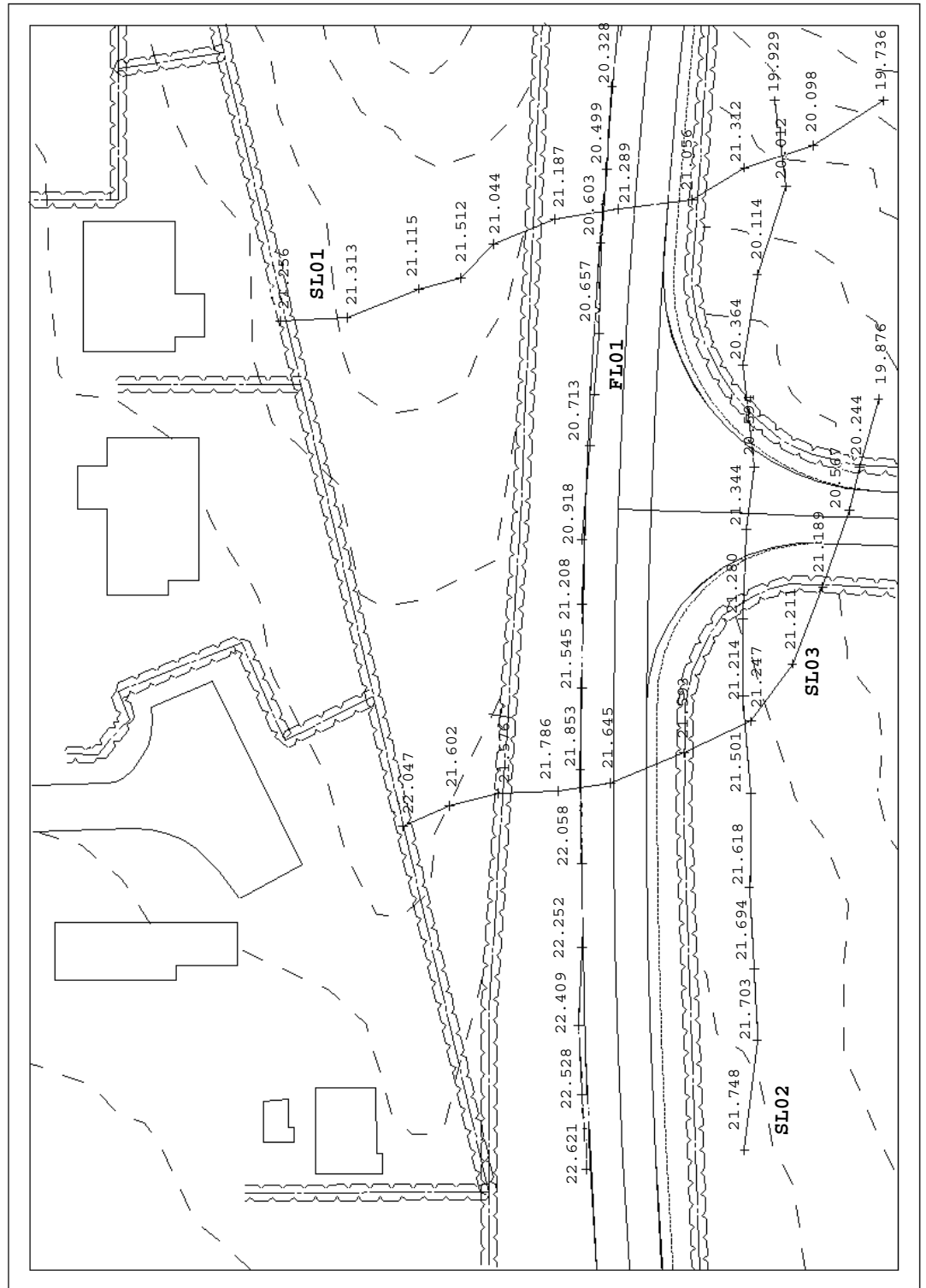


Figure 5 - 60 Model used for survey accuracy validation

Example

Figure 5 - 60 illustrates the model which was used for this example. The check strings were observed in the field by precise methods and processed with major option SURVEY. Three general check strings SL01, SL02 and

SL03 and one check feature string FL01 were recorded and are shown on the plan together with the levels of the observed points.

Long sections are determined for the three general check strings using SECTION, minor option 171. The start and end of these sections should be checked for being equal to the original string, otherwise if they are shorter they will dictate the start and end of the common section of the two strings for the analysis by the REPORT, minor option 998. The check feature string must also be compared with the model string to determine the common length.

The REPORT option is used to analyse the vertical accuracy of the general coverage strings and the significance level is specified as 80%. The feature strings are analysed for both vertical and horizontal accuracy with an 80% significance level.

Input for obtaining sections:

```
SECTION, SAMPLE GROUND MODEL, SAMPLE TEST AREAS
SECTION, SAMPLE TEST AREAS
171, SL01, SINT, S001
171, SL02, SINT, S002
171, SL03, SINT, S003
999
```

Input for accuracy analysis:

```
REPORT, SAMPLE TEST AREAS
998, SL01, S001, 6=2, 80, , 12
998, SL02, S002, 7=80, , 14
998, SL03, S003, 7=80, , 13
999
```

```
REPORT, SAMPLE TEST AREAS, SAMPLE GROUND MODEL
998, FL01, C001, 7=80, , 10
999
```

## Output

Only the first general string (SL01) is reported.

```
LATERAL AND VERTICAL DISPLACEMENTS OF STRING S001 FROM STRING SL01
----REFERENCE STRING SL01 ---- --DIFF S001 FROM SL01
POINT  DIST/CHAIN- ---LEVEL--- --OFFSET-- LEVEL DIFF.
      2          7.268      21.313      0.287      -0.051
      3          13.921     21.115      0.000     -0.085
      4          19.610     21.512      0.088     -0.111
      5          23.780     21.044      0.003      0.008
      6          27.577     21.187      0.000     -0.043
      7          31.090     21.289      0.130     -0.149
      8          34.697     20.506      0.000      0.046
      9          42.710     20.312      0.000      0.012
     10          50.067     20.098      0.000     -0.004
     11          57.734     19.736      0.000      0.027
     12          63.720     19.412     -0.082     -0.096

      NO.OF PNTS ---MEAN--- -STANDARD-- --CONFIDENCE INTERVAL SIGNIFICANCE
                        -DEVIATION-  ---LEFT---- --RIGHT--
VERTICAL  11      -0.0407   0.0632      -0.067      -0.015      80.000
LATERAL   11       0.0398   0.0985      -0.002       0.079      80.000
```

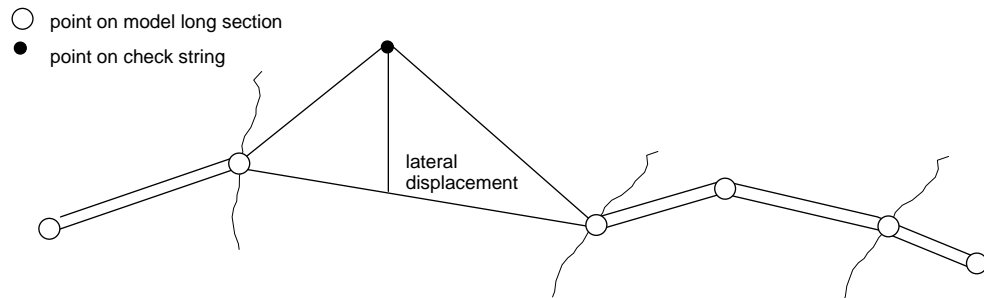
The check feature string (FL01) follows.

```
LATERAL AND VERTICAL DISPLACEMENTS OF STRING C001 FROM STRING FL01
-----REFERENCE STRING FL01 ----- --DIFF C001 FROM FL01--
POINT  DIST/CHAIN- ---LEVEL--- --OFFSET-- LEVEL DIFF.
1      0.000      22.621      -0.273      0.015
2     10.361     22.528      0.449      0.010
3     19.869     22.409     -0.118     -0.008
4     30.962     22.252      0.085     -0.021
5     40.263     22.058      0.068     -0.014
6     50.429     21.853     -0.101     -0.028
7     60.565     21.545     -0.024     -0.028
8     70.412     21.208     -0.026      0.015
9     81.053     20.918     -0.384      0.015
10    91.017     20.713     -0.106     -0.015

NO.OF PNTS ---MEAN--- -STANDARD-- --CONFIDENCE INTERVAL SIGNIFICANCE
          -DEVIATION- ---LEFT--- --RIGHT--
VERTICAL  10    -0.0059  0.0173    -0.014  0.002  80.000
LATERAL   10    -0.0429  0.2200    -0.140  0.054  80.000
```

The output illustrates the vertical and horizontal offsets of the model strings from each point on the check string. In the case of the general check string SL01 the results show unexpected horizontal offsets (ie, 0.287 and 0.130) which should not occur as the model string is the long section derived from the field string. The differences occur because the section routines were unable to determine levels at some of the points on the check string. This is because the plan position of a section is assumed to be the line between all the derived points, and so there is a slight discrepancy in the position of the two sections.

These anomalies do not affect the results and can be ignored.



**Figure 5 - 61 Example showing lateral displacement**

Once all the results have been obtained, they should be presented in a similar fashion to that shown in Figure 5 - 58 to enable their interpretation.

## Major option SETOUT

The setting out minor options are complementary and provide a comprehensive range of facilities. They are designed primarily for highway applications but can be used to set out any strings that contain spatial coordinates as the initial parameters of each string element.

The facilities offered are:

- 180 Storage of stations
- 181 Setting out by deflection angles
- 182 Setting out by intersecting rays from survey stations
- 183 Setting out by offsets from a base line

The choice of minor options will depend on the complexity of the task and more than one option may be used to set out a string. Major highway alignments or features will initially be located by key points from the established survey stations (minor option 182), then located by deflection angles and distances between these key points (minor option 181). Every point on a string could be set out by intersecting rays but in the case of highway alignments, where the points are in close proximity, the setting out errors may be highlighted to the detriment of the smooth alignment and therefore it is better to set out by deflection angles along the length of the line between selected key points. For minor alignment schemes and local features it may be more convenient to use minor option 183 and set out strings from existing survey transverse lines.

These choices remain with the engineer and the major option has been designed so that several minor options may be carried out with one call of the major option. The options also allow for all or part of a string to be set out by going either forwards or backwards along a string.

### Data preparation

Major option SETOUT

1st Model 1 TCode the model which contains the strings to be set out.

2nd Model 2 TCode the model in which any reference stations reside. If left blank it will be assumed that all the stations are in model 1.

### Minor option 180 Add, amend, or delete reference stations

Minor option 180 allows you to add, amend, or delete reference stations from the reference point string.

When using the SURVEY and SETOUT options in MOSS it is necessary to refer to a series of survey stations. These may be input directly or they may have been stored in the system by a previous job.

Survey stations are stored in a string with a special label which is PSSA by default. This label may be changed using minor option 017. Change will only be necessary for larger surveys where it is desirable to use more than one set of stations. Each survey station string must start with the letter P and it is desirable to use the letters SS to qualify the label further.

To input any new station or to delete or change the information about existing stations, use minor option 018.

The survey reference stations are stored in a point string which may be within a general model or in a station model created specifically for this purpose. If a station model is used it must have been created in the normal manner by using major option CREATE prior to running this option. The survey station point string contains the easting and northing coordinates, the level and the station reference for all stations that are to be requested by minor options within the major option. Unlike other strings a survey station string has a pre-defined label (PSSA) and this will be made available by the system as soon as the model name containing the string is encountered. Facilities exist to add, amend or delete points from the point string. Upon completion of the major option any corrections to the survey stations are re-filed in the model.

◇ *A PSSA string has a maximum of 400 points.*

## Input data

### Minor option 180

- \* Field 3        Station reference
- Field 4        Code -1.0 if a station is to be deleted
- \* Field 5        Easting coordinate
- \* Field 6        Northing coordinate
- Field 7        Level; if omitted a null level is assumed (-999.0)

If station details are to be amended, specify the station reference and respecify the coordinates and/or level.

## Example

```
MOSS EDIT SURVEY STATIONS EXAMPLE
SETOUT SIMPLE STATION MODEL
180,,,STNE,,501445.746,111198.347,58.000
180,,,STNG,,501376.343,111168.496,56.897
180,,,STNB,-1
999
SETOUT SIMPLE STATION MODEL
180,,,STNA,,501515.678,111228.426,46.353
180,,,STNE,,501445.746,111198.347,51.736
180,,,STNG,,501376.343,111168.496,56.897
180,,,STNB,,501303.120,111137.001,61.056
180,,,STNC,,501197.642,111114.127,64.506
180,,,STNN,,501244.076,111180.403,69.720
180,,,STNK,,501325.380,111195.408,65.180
```

```

180,,,STNL,,501396.621,111221.886,60.150
180,,,STNM,,501468.524,111245.109,54.600
180,,,STND,,501486.109,111175.228,43.260
180,,,STNF,,501435.109,111174.996,49.630
180,,,STNH,,501340.401,111119.931,54.590
180,,,STNJ,,501267.643,111097.972,58.560
999

```

DATE : 24/ 8/95 TIME : 15:16:50  
EDIT SURVEY STATIONS EXAMPLE

PAGE : 1

MOSS EDIT SURVEY STATIONS EXAMPLE

```

SETOUT SIMPLE STATION MODEL
180 STNE 501445.746111198.347 58.000

180 STNG 501376.343111168.496 56.897
180 STNB -1

```

```

W578 STATION STNE CHANGED FROM :
501445.746 111198.347
51.736

```

```

W679 STATION STNB DELETED
FROM STATIONS STRING

```

999

```

SETOUT SIMPLE STATION MODEL
180 STNA 501515.678111228.426 46.353
180 STNE 501445.746111198.347 51.736

```

```

W578 STATION STNE CHANGED FROM :
501445.746 111198.347
58.000

```

```

180 STNG 501376.343111168.496 56.897
180 STNB 501303.120111137.001 61.056
180 STNC 501197.642111114.127 64.506
180 STNN 501244.076111180.403 69.720
180 STNK 501325.380111195.408 65.180
180 STNL 501396.621111221.886 60.150
180 STNM 501468.524111245.109 54.600
180 STND 501486.109111175.228 43.260
180 STNF 501435.109111174.996 49.630
180 STNH 501340.401111119.931 54.590
180 STNJ 501267.643111097.972 58.560
999

```

SETOUT,EAST WEST ROUTE SURVEY STATIONS

STORE SURVEY STATION COORDINATES

```

180,3=STN1,5=431417.810,6=537530.210
180,3=STN2,5=431460.432,6=537460.912
180,3=STN3,5=431540.029,6=537633.731
180,3=STN4,5=431583.120,6=537577.926
180,3=STN5,5=431629.891,6=537560.410
180,3=STN6,5=431743.528,6=537599.958
999

```

## Minor option 181 Setting out a string by deflection angles

Minor option 181 provides the traditional setting-out information for ranging an alignment string or string feature by deflection angles. Any string may be set out by this option provided the initial parameters of each string element (point) are its coordinates. An initial point is defined on the string which is the first instrument station and will have been previously set out. The deflection angles refer to a reference station and are given for all points on the string up to the defined end point.

A facility is incorporated to move the instrument station along the string. The distance along the string is specified for this feature and the deflection angles are determined up to the new station, which will be the nearest point



on the string after the specified interval. The previous instrument station is then used as the reference station and deflection angles determined for further string points. If the fixed interval for the advance of instrument station is not practical then several runs of this minor option should be initiated between the required points or chainages. A second reference station may be specified for the calculation of a check angle from the specified end point.

◇ *The deflection angles given are always positive and may therefore be greater than 180°.*

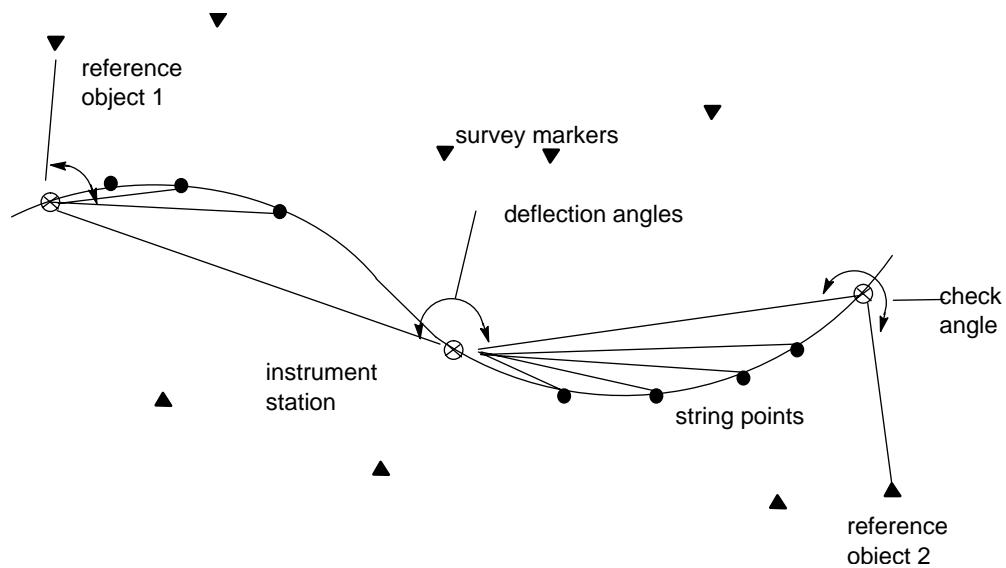


Figure 5 - 62 Setting out - deflection angles

**Input**

Minor option 181

- \* Field 1 Reference string
- \* Field 2 First reference station
- Field 3 Second reference station (if check angle required)
- Field 4 Chainage interval (optional and only if reference string is a master string)
- Field 5 & 6 Chainage or coordinates of start point on reference string
- Field 7 Instrument interval (if not required leave blank)
- Field 8 & 9 Chainage or coordinates of end point on reference string

Example

The example refers to Figure 5 - 66Figure 5 - 62. .The three minor options allow The first example shows for the setting out by deflection angles of the alignment from chainage 150 to 3101400.0 to 2000, using three stations STNG, STNB and STNN, and moving the instrument twice. By.@@@@y deflection angles - by breaking the distance into three separate lengths, rather than by simply introducing an instrument interval, check sights are obtained at intermediate points. The second example uses two stations and moves the instrument twice, A an instrument interval has been introduced in the second of the option.s and in the last option the check station has been omitted to illustrate that it is optional.

SETOUT,EW ROUTE MAIN ALIGNMENT,EAST WEST ROUTE SURVEY STATIONS

SETTING OUT BY DEFLECTION ANGLES

181,MH21,STN1,STN5,,1400.0,8=1600.0  
181,MH21,STN5,STN8,,1600.0,7=100.0,1800.0

999

MOSS

Example 1 ch. 150 - 310 using 3 stations and moving the instrument twice.

SETOUT,SIMPLE DESIGN ROAD,SIMPLE STATION MODEL

181,MAST,STNG,STNB,10,150,,230  
181,MAST,STNB,STNN,,230,8=310

999

Example 2 ch. 150 - 310 using 2 stations and moving the instrument twice.

SETOUT,SIMPLE DESIGN ROAD,SIMPLE STATION MODEL

181,MAST,STNG,STNN,,150,7=80,8=310

999

DATE : 25/ 8/95 TIME : 08:51:22  
MOSS

PAGE : 1

MOSS

Example 1 ch. 150 - 310 using 3 stations and moving the instrument twice.

SETOUT SIMPLE DESIGN ROAD

SIMPLE STATION MODEL

181MASTSTNGSTNB 10 150

230

\$

W676 NO INST. INTERVAL SPECIFIED

1

DATE : 25/ 8/95 TIME : 08:51:23  
MOSS

PAGE : 2

PNT	---X---	-----Y----	-----Z---	-CHAINAGE-	-DEFLN ANG-	DEFLN DIST	CHORD DIST
STNG	501376.343	111168.496	56.897				
18	501377.068	111178.286	57.494	150.000	0 0 0.0	0.000	0.000
19	501367.444	111175.570	58.251	160.000	70 0 28.9	10.000	10.000
20	501357.782	111172.992	59.008	170.000	70 25 2.2	19.999	10.000
21	501348.084	111170.553	59.762	180.000	70 49 35.5	29.998	10.000
22	501338.352	111168.252	60.515	190.000	71 14 8.8	39.995	10.000
23	501328.589	111166.090	61.267	200.000	71 38 42.1	49.989	10.000
24	501318.796	111164.068	62.018	210.000	72 3 15.5	59.982	10.000

REFERENCE STATION  
POINT 18 TO STATION STNG  
BEARING 184 13 59.3  
DISTANCE 9.817



# CHAPTER 5 MAJOR OPTION SETOUT

```

25  501308.974  111162.186  62.766  220.000  72 27 48.8  69.971  10.000
26  501299.127  111160.444  63.514  230.000  72 52 22.1  79.956  10.000
MOVE INSTRUMENT TO POINT  26
POINT 26 TO POINT 18
BEARING  77  6 21.4
DISTANCE  79.956
STNB  501303.120  111137.001  61.056
REFERENCE STATION
POINT 26 TO STATION STNB
BEARING 170 20  4.4
DISTANCE  23.781

```

```

1
DATE : 25/ 8/95 TIME : 08:51:23          PAGE : 3
MOSS

```

```

181MASTSTNBSTNN          230          310
$
W676 NO INST. INTERVAL SPECIFIED

```

```

1
DATE : 25/ 8/95 TIME : 08:51:23          PAGE : 4
MOSS

```

```

PNT  ---X---  ---Y---  ---Z---  -CHAINAGE-  -DEFLN ANG-  DEFLN DIST  CHORD DIST
STNB 501303.120  111137.001  61.056
REFERENCE STATION
POINT 26 TO STATION STNB
BEARING 170 20  4.4
DISTANCE  23.781

```

```

26  501299.127  111160.444  63.514  230.000  0 0 0.0  0.000  0.000
27  501289.256  111158.844  64.259  240.000  90 27 16.9  10.000  10.000
28  501279.364  111157.384  64.992  250.000  90 51 50.2  19.999  10.000
29  501269.451  111156.066  65.712  260.000  91 16 23.6  29.998  10.000
30  501259.520  111154.890  66.420  270.000  91 40 56.9  39.995  10.000
31  501249.574  111153.855  67.114  280.000  92  5 30.2  49.989  10.000
32  501239.614  111152.963  67.796  290.000  92 30  3.5  59.982  10.000
33  501232.334  111152.402  68.285  297.302  92 47 59.4  67.276  7.302
34  501229.642  111152.214  68.465  300.000  92 54 36.7  69.971  2.698
35  501219.661  111151.602  69.120  310.000  93 18 57.7  79.957  10.000

```

```

MOVE INSTRUMENT TO POINT  35
POINT 35 TO POINT 26
BEARING  83 39  2.0
DISTANCE  79.957

```

```

STNN 501244.076  111180.403  69.720
REFERENCE STATION
POINT 35 TO STATION STNN
BEARING  40 17 16.5
DISTANCE  37.757

```

```

1
DATE : 25/ 8/95 TIME : 08:51:23          PAGE : 5
MOSS

```

```

999
Example 2 ch. 150 - 310 using 2 stations and moving the instrument twice.

```

```

SETOUT SIMPLE DESIGN ROAD          SIMPLE STATION MODEL
181MASTSTNGSTNN          150          80          310

```

```

1
DATE : 25/ 8/95 TIME : 08:51:23          PAGE : 6
MOSS

```

```

PNT  ---X---  ---Y---  ---Z---  -CHAINAGE-  -DEFLN ANG-  DEFLN DIST  CHORD DIST
STNG 501376.343  111168.496  56.897
REFERENCE STATION
POINT 18 TO STATION STNG
BEARING 184 13 59.3
DISTANCE  9.817

```

```

18  501377.068  111178.286  57.494  150.000  0 0 0.0  0.000  0.000
19  501367.444  111175.570  58.251  160.000  70 0 28.9  10.000  10.000
20  501357.782  111172.992  59.008  170.000  70 25  2.2  19.999  10.000
21  501348.084  111170.553  59.762  180.000  70 49 35.5  29.998  10.000
22  501338.352  111168.252  60.515  190.000  71 14  8.8  39.995  10.000
23  501328.589  111166.090  61.267  200.000  71 38 42.1  49.989  10.000
24  501318.796  111164.068  62.018  210.000  72  3 15.5  59.982  10.000
25  501308.974  111162.186  62.766  220.000  72 27 48.8  69.971  10.000
26  501299.127  111160.444  63.514  230.000  72 52 22.1  79.956  10.000

```

```

MOVE INSTRUMENT TO POINT  26
POINT 26 TO POINT 18
BEARING  77  6 21.4

```



# CHAPTER 5 MAJOR OPTION SETOUT

```

DISTANCE      79.956

27  501289.256  111158.844  64.259  240.000  183 40 59.9  10.000  10.000
28  501279.364  111157.384  64.992  250.000  184 5 33.2  19.999  10.000
29  501269.451  111156.066  65.712  260.000  184 30 6.5  29.998  10.000
30  501259.520  111154.890  66.420  270.000  184 54 39.8  39.995  10.000
31  501249.574  111153.855  67.114  280.000  185 19 13.2  49.989  10.000
32  501239.614  111152.963  67.796  290.000  185 43 46.5  59.982  10.000
33  501232.334  111152.402  68.285  297.302  186 1 42.3  67.276  7.302
34  501229.642  111152.214  68.465  300.000  186 8 19.7  69.971  2.698
35  501219.661  111151.602  69.120  310.000  186 32 40.6  79.957  10.000

MOVE INSTRUMENT TO POINT 35

POINT 35 TO POINT 26
BEARING 83 39 2.0
DISTANCE 79.957

1
DATE : 25/ 8/95 TIME : 08:51:23
MOSS
PAGE : 7

STNN 501244.076  111180.403  69.720

REFERENCE STATION
POINT 35 TO STATION STNN
BEARING 40 17 16.5
DISTANCE 37.757

1
DATE : 25/ 8/95 TIME : 08:51:23
MOSS
PAGE : 8

999
W201 END OF INPUT DATA FILE REACHED

EAST WEST ROUTE SETTING OUT
181MH21STN5STN8 1600.0 100.0 180.0

EAST WEST ROUTE SETTING OUT
POINT ---X--- ---Y--- ---Z--- -CHAINAGE- -DEFLN ANG- DEFLN DIST CHORD DIST
STN5 431629.891 537650.410 -999.000
REFERENCE STATION
STN5 POINT 29 TO STATION
BEARING 330 21 24.4
DISTANCE 66.640

29 431662.851 537592.492 98.474 1600.000 0 0 0.0 0.0 0.0
30 431682.775 537594.218 99.715 1620.000 114 11 28.5 19.999 19.999
31 431692.712 537595.343 100.431 1630.000 114 11 19.4 29.997 10.000
32 431702.618 537596.710 101.189 1640.000 113 35 18.1 39.990 10.000
33 431712.479 537598.370 101.976 1650.000 112 53 19.9 49.975 10.000
34 431722.275 537600.372 102.775 1660.000 112 5 22.3 59.945 9.999
35 431725.000 537601.000 102.999 1662.796 111 50 53.4 62.729 2.796
36 431733.334 537683.128 103.683 1671.398 111 3 43.6 71.281 8.602
37 431741.589 537685.548 104.353 1680.000 110 13 47.0 79.813 8.602
38 431751.074 537608.710 105.100 1690.000 109 13 37.2 89.702 9.999
39 431760.430 537612.239 105.800 1700.000 108 12 10.9 99.558 9.999

MOVE INSTRUMENT TO POINT 39
POINT 39 TO POINT 29
BEARING 258 33 35.3
DISTANCE 99.558

40 431769.647 537616.118 106.440 1710.000 168 36 53.6 9.999 9.999
41 431778.715 537620.332 107.022 1720.000 167 33 49.3 19.996 9.999
42 431787.626 537624.868 107.547 1730.000 166 31 51.7 59.985 9.999
43 431796.375 537629.711 108.021 1740.000 165 30 58.3 39.966 10.000
44 431804.954 537634.848 108.446 1750.000 164 31 6.2 49.935 10.000
45 431813.358 537640.267 108.826 1760.000 163 32 12.3 59.891 10.000
46 431821.582 537645.955 109.165 1770.000 162 34 13.3 69.831 10.000
47 431829.622 537651.901 109.466 1780.000 161 37 5.6 79.753 10.000
48 431837.100 537657.790 109.720 1789.519 160 43 27.3 89.180 9.519
49 431844.402 537663.896 109.946 1799.038 159 50 29.1 98.588 9.519
50 431845.130 537664.525 109.968 1800.000 459 45 9.9 99.538 0.962

EAST WEST ROUTE SETTING OUT
POINT ---X--- ---Y--- ---Z--- -CHAINAGE- -DEFLN ANG- DEFLN DIST CHORD DIST
MOVE INSTRUMENT TO POINT 50
POINT 50 TO POINT 39
BEARING 238 1845.2
DISTANCE 99.538

STN8 431879.310 537643.008 -999.0001
REFERENCE STATION
STN8 POINT 50 TO STATION
BEARING 122 11 28.7
DISTANCE 40.388

```

## Minor option 182 Setting out a string by intersecting rays

Setting out a string by intersecting rays from survey markers.

Permanent survey markers are usually located adjacent to the route of a highway and may take the form of aerial survey markers, traverse stations or special setting out stations. Minor option 182 calculates bearings, distances and deflection angles from a base line between a pair of these stations to all the points on a string between defined start and end points.

In the case of highway alignment it is not recommended that every chainage interval or string point is set out in this manner as this will highlight the setting out errors. The introduction to this major option recommends that minor option 181 should be used in conjunction with this option to obtain a satisfactory result. However, by obtaining a comprehensive tabulation of setting out information for all the points the engineer has freedom in the field to select the key points prior to running option 181 to obtain deflection angle setting out details between them. More than two intersecting rays may be obtained for establishing a single point by repeating the minor option for further pairs of survey stations.

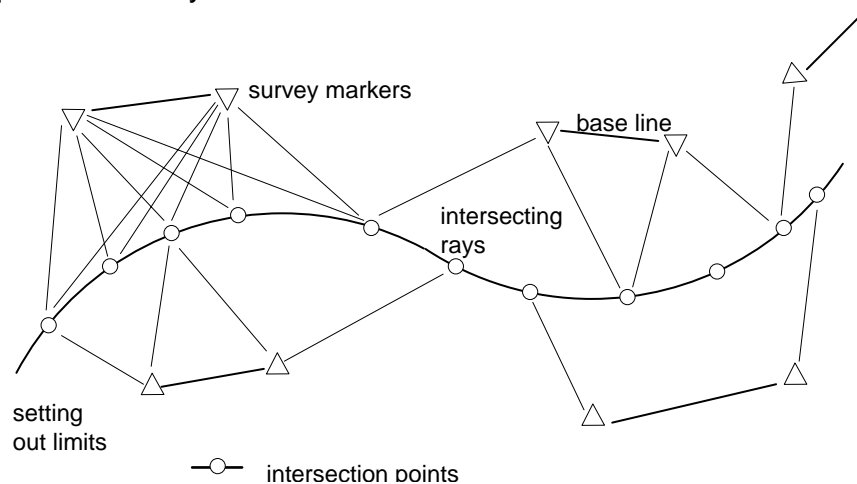


Figure 5 - 63 Setting out - intersecting rays

### Input

#### Minor option 182

- \* Field 1 Reference string
- \* Field 2 First survey station reference
- \* Field 3 Second survey station reference
- Field 4 Chainage interval (optional and only if reference string is a master string)
- Field 5 & 6 Chainage or coordinates of start point on reference string
- Field 8 & 9 Chainage or coordinates of end point on reference string

Example

The example refers to Figure 5 - 66. the example shown in Figure 5 - 63. Four pairs of stations have been entered on threefour minor options to produce comprehensive setting out data that will be used in conjunction with minor option 181. Where the chainage ranges overlapthird and fourth options the points on the alignment will be fixed by more than two rays.

MOSS

SETOUT, SIMPLE DESIGN ROAD, SIMPLE STATION MODEL

182,MAST,STNN,STNK,5=150,,,310

182,MAST,STNH,STNG,5=150,,,250

182,MAST,STNJ,STNB,5=200,,,310

999

DATE : 25/ 8/95 TIME : 09:47:42 PAGE : 1  
MOSS

MOSS

SETOUT SIMPLE DESIGN ROAD SIMPLE STATION MODEL  
182MASTSTNNSTNK 150 310

1  
DATE : 25/ 8/95 TIME : 09:47:42 PAGE : 2  
MOSS

REFERENCE STATIONS

	-----X-----	-----Y-----	-----Z-----	--BEARING--	-DISTANCE-
STNN	501244.076	111180.403	69.720		
STNK	501325.380	111195.408	65.180	79 32 36.5	82.677

PNT	-----X-----	-----Y-----	-----Z-----	CHAINAGE	BEARING	1-P	DST	1-P	DEFLN	2-1-P
18	501377.068	111178.286	57.494	150.000	90 54 42.6	133.008	11 22	6.0		
19	501367.444	111175.570	58.251	160.000	92 14 35.6	123.462	12 41	59.1		
20	501357.782	111172.992	59.008	170.000	93 43 44.0	113.947	14 11	7.5		
21	501348.084	111170.553	59.762	180.000	95 24 36.9	104.473	15 52	0.4		
22	501338.352	111168.252	60.515	190.000	97 20 40.1	95.056	17 48	3.6		
23	501328.589	111166.090	61.267	200.000	99 36 45.0	85.716	20 4	8.5		
24	501318.796	111164.068	62.018	210.000	102 19 55.5	76.484	22 47	19.0		
25	501308.974	111162.186	62.766	220.000	105 40 47.0	67.407	26 8	10.5		
26	501299.127	111160.444	63.514	230.000	109 55 41.1	58.558	30 23	4.6		
27	501289.256	111158.844	64.259	240.000	115 30 35.6	50.061	35 57	59.1		
28	501279.364	111157.384	64.992	250.000	123 7 2.9	42.132	43 34	26.3		
29	501269.451	111156.066	65.712	260.000	133 48 14.3	35.159	54 15	37.8		
30	501259.520	111154.890	66.420	270.000	148 48 41.5	29.824	69 16	5.0		
31	501249.574	111153.855	67.114	280.000	168 17 57.5	27.111	88 45	21.0		
32	501239.614	111152.963	67.796	290.000	189 14 9.8	27.800	109 41	33.3		
33	501232.334	111152.402	68.285	297.302	202 45 3.9	30.364	123 12	27.4		
34	501229.642	111152.214	68.465	300.000	207 6 49.2	31.670	127 34	12.7		
35	501219.661	111151.602	69.120	310.000	220 17 16.5	37.757	140 44	40.0		

1  
DATE : 25/ 8/95 TIME : 09:47:43 PAGE : 3  
MOSS

182MASTSTNHSTNG 150 250

1  
DATE : 25/ 8/95 TIME : 09:47:43 PAGE : 4  
MOSS

REFERENCE STATIONS

	-----X-----	-----Y-----	-----Z-----	--BEARING--	-DISTANCE-
STNH	501340.401	111119.931	54.590		
				36 30 15.9	60.418

```

STNG  501376.343  111168.496  56.897
PNT  -----X-----Y-----Z--  CHAINAGE BEARING 1-P DST 1-P DEFLN 2-1-P
18  501377.068  111178.286  57.494  150.000  32  8  33.2  68.919  355  38  17.3
19  501367.444  111175.570  58.251  160.000  25  55  16.5  61.863  349  25  0.6
20  501357.782  111172.992  59.008  170.000  18  8  12.0  55.835  341  37  56.1
21  501348.084  111170.553  59.762  180.000  8  37  48.5  51.201  332  7  32.6
22  501338.352  111168.252  60.515  190.000  357  34  20.6  48.364  321  4  4.8
23  501328.589  111166.090  61.267  200.000  345  38  45.8  47.646  309  8  29.9
24  501318.796  111164.068  62.018  210.000  333  55  4.0  49.141  297  24  48.1
25  501308.974  111162.186  62.766  220.000  323  21  37.0  52.660  286  51  21.1
26  501299.127  111160.444  63.514  230.000  314  28  2.1  57.835  277  57  46.2
27  501289.256  111158.844  64.259  240.000  307  15  54.2  64.265  270  45  38.3
28  501279.364  111157.384  64.992  250.000  301  32  0.9  71.612  265  1  45.0

```

```

1
DATE : 25/ 8/95 TIME : 09:47:43          PAGE : 5
MOSS

```

```

182MASTSTNJSTNB          200          310

```

```

1
DATE : 25/ 8/95 TIME : 09:47:43          PAGE : 6
MOSS

```

REFERENCE STATIONS

```

-----X-----Y-----Z--- --BEARING-- -DISTANCE-
STNJ  501267.643  111097.972  58.560          42 16 14.0  52.744
STNB  501303.120  111137.001  61.056

```

```

PNT  -----X-----Y-----Z--  CHAINAGE BEARING 1-P DST 1-P DEFLN 2-1-P
23  501328.589  111166.090  61.267  200.000  41  49  10.2  91.403  359  32  56.2
24  501318.796  111164.068  62.018  210.000  37  44  13.1  83.578  355  27  59.1
25  501308.974  111162.186  62.766  220.000  32  46  3.2  76.365  350  29  49.3
26  501299.127  111160.444  63.514  230.000  26  44  48.9  69.957  344  28  34.9
27  501289.256  111158.844  64.259  240.000  19  32  53.5  64.595  337  16  39.5
28  501279.364  111157.384  64.992  250.000  11  9  35.1  60.557  328  53  21.1
29  501269.451  111156.066  65.712  260.000  1  46  56.7  58.122  319  30  42.8
30  501259.520  111154.890  66.420  270.000  351  52  41.7  57.494  309  36  27.7
31  501249.574  111153.855  67.114  280.000  342  4  56.3  58.732  299  48  42.3
32  501239.614  111152.963  67.796  290.000  332  59  31.8  61.723  290  43  17.8
33  501232.334  111152.402  68.285  297.302  327  1  40.5  64.880  284  45  26.5
34  501229.642  111152.214  68.465  300.000  324  59  8.0  66.228  282  42  54.1
35  501219.661  111151.602  69.120  310.000  318  10  52.6  71.961  275  54  38.7

```

```

1
DATE : 25/ 8/95 TIME : 09:47:43          PAGE : 7
MOSS

```

999

```

SETOUT BF6543
182M001STN1STN2

```

REFERENCE STRINGS

```

-----X-----Y-----Z--- --BEARING-- -DISTANCE-
STN1  100.000          100.000          -999.000          95 42 38.1  50.249
STN2  150.000          95.000          -999.000

```

```

PNT  -----X-----Y-----Z--  CHAINAGE BEARING 1-P DST 1-9 DEFLN 2-1-P
1    104.000          110.000          20.000          0.000  21 48 5.1          10.770 286 5 26.9
2    120.000          110.000          24.170          16.000  63 26 5.8          22.361 327 43 27.7
3    120.000          115.000          26.238          21.000  53 7 48.4          25.000 317 25 10.2
4    130.000          115.000          29.475          31.000  63 26 5.8          33.541 327 43 27.7
5    130.000          110.000          30.000          36.000  71 33 54.2          31.623 335 51 16.0
6    140.000          110.000          30.000          46.000  75 57 49.5          41.231 340 15 11.4

```

### Minor option 183 Setting out by offsets

Setting out by offsets from a base line.

This option determines distance and offsets to points on a string from a base line. It will generally apply to minor highway improvements where existing traverse stations are available to set out details. Figure 5 - 64 and Figure 5 - 65 illustrate both the normal situation where only one section of the string is adjacent to the base line, and how a meandering string can have several sections which can be set out from the defined base line. If no limits are specified the option will determine setting out details for all such sections that are feasible but they can be restricted by defining appropriate start and end points on the string. The sign conventions for the distances and offsets are that distances are positive along the base line in the direction the stations are specified and offsets are positive to the right, negative to the left of this direction.

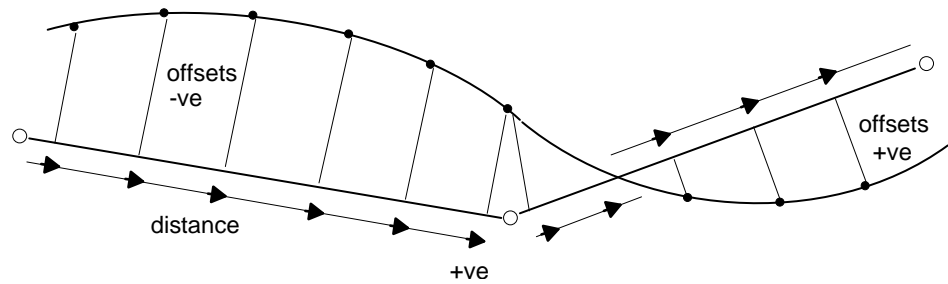


Figure 5 - 64 Example Offsets from baseline (simple case)

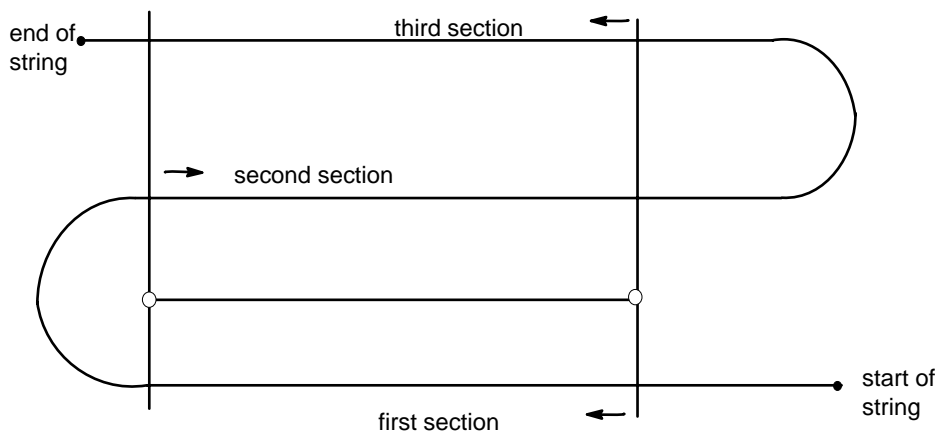


Figure 5 - 65 Example Offsets from baseline (complex case)

#### Input

##### Minor option 183

- \* Field 1 Reference string
- \* Field 2 First survey station



- \* Field 3      Second survey station
- Field 4      Chainage interval (optional and only if reference string is a master string)
- Field 5 & 6    Chainage or coordinates of start point on reference string - optional
- Field 8 & 9    Chainage or coordinates of end point on reference string - optional

Example

Inspection of the route in Figure 5 - 66 shows that for part of its length it closely follows the existing road and because of the location of survey stations on the old road this minor option is a convenient means of setting out part of the new route. The first, and second and third of the options provide setting out data for all adjacent alignment points and the fourth third option limits the information to a specific range.

MOSS

SETOUT, SIMPLE DESIGN ROAD, SIMPLE STATION MODEL

183, MAST, STNa, STNe

183, MAST, STNe, STNG

183, MAST, STNg, STNB

183, MAST, STNb, STNn, 8=270

999

DATE : 25/ 8/95 TIME : 14:16:58 PAGE : 1  
MOSS

MOSS

SETOUT SIMPLE DESIGN ROAD SIMPLE STATION MODEL  
183MASTSTNASTNE

1  
DATE : 25/ 8/95 TIME : 14:16:59 PAGE : 2  
MOSS

REFERENCE STATIONS

	-----X----	-----Y----	-----Z----	--BEARING--	-DISTANCE-	
STNA	501515.678	111228.426	46.353	246 43 35.8	76.126	
STNE	501445.746	111198.347	51.736			
PNT	-----X----	-----Y----	-----Z----	-CHAINAGE-	-DISTANCE-	--OFFSET--
2	501507.816	111228.045	47.040	10.000	7.373	2.756
3	501505.392	111227.001	47.225	12.639	10.012	2.755
4	501498.631	111224.090	47.744	20.000	17.373	2.752
5	501489.442	111220.145	48.457	30.000	27.373	2.759
6	501480.243	111216.223	49.179	40.000	37.373	2.791
7	501471.029	111212.336	49.910	50.000	47.373	2.861
8	501461.795	111208.499	50.649	60.000	57.372	2.985
9	501452.535	111204.724	51.397	70.000	67.370	3.176

1  
DATE : 25/ 8/95 TIME : 14:16:59 PAGE : 3  
MOSS

183MASTSTNESTNG

1  
DATE : 25/ 8/95 TIME : 14:16:59 PAGE : 4  
MOSS

REFERENCE STATIONS

	-----X----	-----Y----	-----Z----	--BEARING--	-DISTANCE-	
STNE	501445.746	111198.347	51.736	246 43 36.9	75.550	
STNG	501376.343	111168.496	56.897			
PNT	-----X----	-----Y----	-----Z----	-CHAINAGE-	-DISTANCE-	--OFFSET--
10	501443.244	111201.024	52.154	80.000	1.240	3.448
11	501433.919	111197.414	52.919	90.000	11.234	3.816
12	501424.554	111193.907	53.685	100.000	21.222	4.294
13	501415.147	111190.516	54.450	110.000	31.204	4.896
14	501412.225	111189.492	54.686	113.096	34.292	5.110

15	501405.693	111187.255	55.213	120.000	41.176	5.636
16	501396.194	111184.129	55.975	130.000	51.137	6.517
17	501386.652	111181.139	56.735	140.000	61.085	7.541
18	501377.068	111178.286	57.494	150.000	71.016	8.707

1  
DATE : 25/ 8/95 TIME : 14:16:59  
MOSS PAGE : 5

183MASTSTNGSTNB  
1  
DATE : 25/ 8/95 TIME : 14:16:59  
MOSS PAGE : 6

REFERENCE STATIONS

-----X----	-----Y----	-----Z----	--BEARING--	-DISTANCE-
STNG 501376.343	111168.496	56.897	246 43 34.6	79.709
STNB 501303.120	111137.001	61.056		

PNT	-----X----	-----Y----	-----Z----	-CHAINAGE-	-DISTANCE-	--OFFSET--
19	501367.444	111175.570	58.251	160.000	5.380	10.015
20	501357.782	111172.992	59.008	170.000	15.274	11.465
21	501348.084	111170.553	59.762	180.000	25.147	13.055
22	501338.352	111168.252	60.515	190.000	34.996	14.786
23	501328.589	111166.090	61.267	200.000	44.819	16.658
24	501318.796	111164.068	62.018	210.000	54.614	18.670
25	501308.974	111162.186	62.766	220.000	64.380	20.822
26	501299.127	111160.444	63.514	230.000	74.114	23.113

1  
DATE : 25/ 8/95 TIME : 14:16:59  
MOSS PAGE : 7

183MASTSTNBSTNN 270  
1  
DATE : 25/ 8/95 TIME : 14:16:59  
MOSS PAGE : 8

REFERENCE STATIONS

-----X----	-----Y----	-----Z----	--BEARING--	-DISTANCE-
STNB 501303.120	111137.001	61.056	306 19 7.8	73.280
STNN 501244.076	111180.403	69.720		

PNT	-----X----	-----Y----	-----Z----	-CHAINAGE-	-DISTANCE-	--OFFSET--
24	501318.796	111164.068	62.018	210.000	3.401	31.093
25	501308.974	111162.186	62.766	220.000	10.199	23.760
26	501299.127	111160.444	63.514	230.000	17.102	16.524
27	501289.256	111158.844	64.259	240.000	24.107	9.388
28	501279.364	111157.384	64.992	250.000	31.214	2.353
29	501269.451	111156.066	65.712	260.000	38.420	-4.580
30	501259.520	111154.890	66.420	270.000	45.725	-11.410

1  
DATE : 25/ 8/95 TIME : 14:16:59  
MOSS PAGE : 9

999

SETOUT, DEMO MODEL  
183, M003, STNA, STNB  
999

REFERENCE STATIONS

	-----X-----	-----Y-----	-----Z-----	--BEARING--	-DISTANCE-	
STNA	1089.415	1645.553	23.899	69 7 14.8	194.366	
STNB	1271.018	1714.825	24.654			
PNT	-----X-----	-----Y-----	-----Z-----	-CHAINAGE-	-DISTANCE-	--OFFSET--
17	1133.823	1551.903	-999.000	140.000	8.115	103.327
18	1143.614	1553.934	-999.000	150.000	17.987	104.920
19	1153.429	1555.850	-999.000	160.000	27.840	106.627
20	1163.265	1557.650	-999.000	170.000	37.673	108.451
21	1173.122	1559.336	-999.000	180.000	47.483	110.389
22	1182.998	1560.906	-999.000	190.000	57.270	112.441
23	1192.892	1562.361	-999.000	200.000	67.032	114.608
24	1202.802	1563.699	-999.000	210.000	76.769	116.890
25	1212.727	1564.922	-999.000	220.000	86.477	119.285
26	1222.665	1566.028	-999.000	230.000	96.158	121.793
27	1232.616	1567.018	-999.000	240.000	105.808	124.415
28	1242.578	1567.891	-999.000	250.000	115.427	127.149
29	1252.549	1568.648	-999.000	260.000	125.013	129.996
30	1262.529	1569.288	-999.000	270.000	134.565	132.955
31	1272.515	1569.811	-999.000	280.000	144.082	136.025
32	1282.507	1570.217	-999.000	290.000	153.562	139.207
33	1292.502	1570.506	-999.000	300.000	163.005	142.499
34	1302.501	1570.678	-999.000	310.000	172.408	145.901
35	1312.501	1570.734	-999.000	320.000	181.771	149.414
36	1322.500	1570.672	-999.000	330.000	191.092	153.035

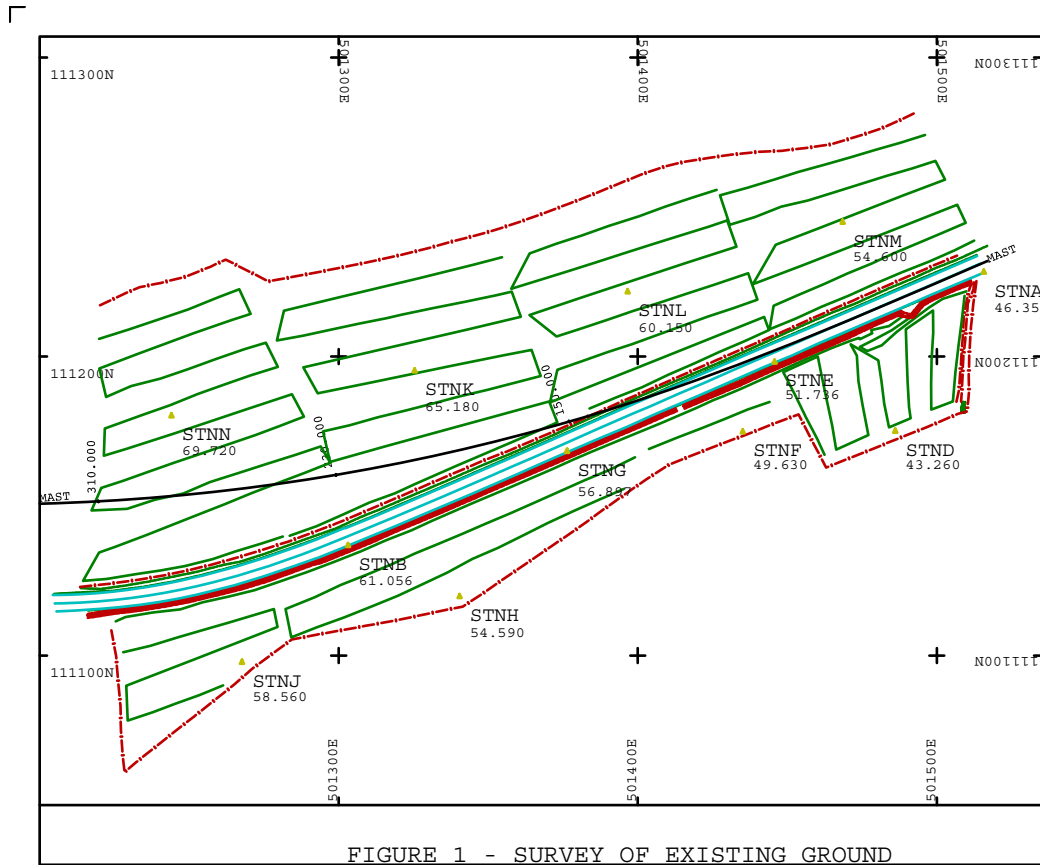
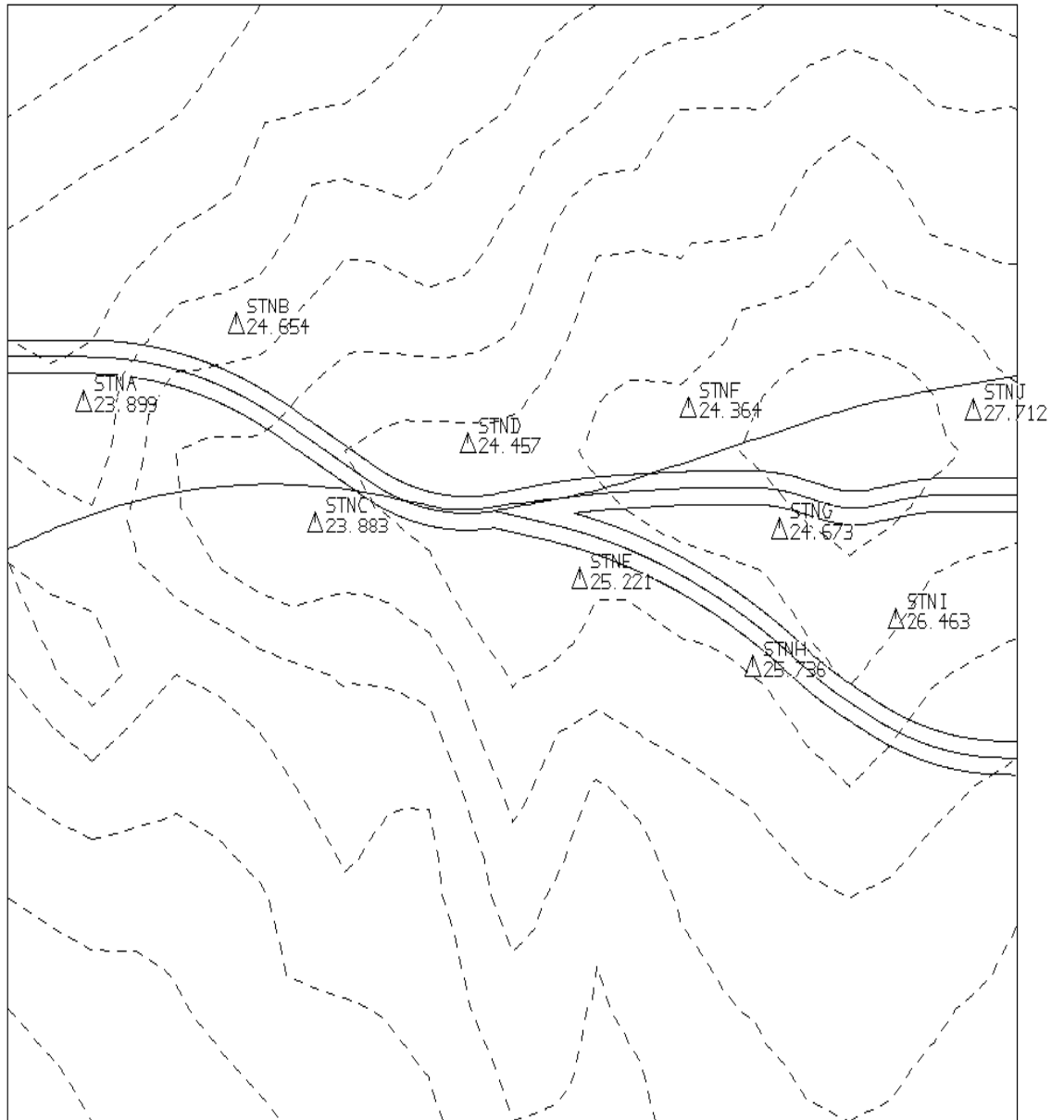


FIGURE 1 - SURVEY OF EXISTING GROUND



**Figure 5 - 66 SETOUT - demo model**

# Chapter 6 Interactive alignment

## Interactive alignment

### Introduction

This chapter describes major option ALIGNMENT which is for designing alignments for roads, railways and other linear engineering features.

Major option ALIGNMENT provides you with the means to interactively design alignments. Complimentary facilities exist in the non-interactive major options HCUSP, HALGN, VCUSP, VERAT and VALGN. Alignments created in major option ALIGNMENT may be converted to master strings for use in the rest of MOSS.

Once the alignment design has been completed, you may use major option DESIGN to design the geometric features of the alignment.

Chapter 6 details -  
    Interactive Alignment

Chapter 7 details -  
    Non-Interactive Alignment  
        major option HCUSP  
        major option HALGN  
        major option VCUSP  
        major option VERAT  
        major option VALGN

Chapter 8 details -  
    Geometric Design  
        major option DESIGN  
        major option INTERFACE

However, you don't need to read these chapters in order to design alignments and features. With ALIGNMENT in particular, your path is guided by the sequence of menus and this documentation is provided for reference.

◇ *For background information on alignment design see the 'Introduction to MOSS' booklet, and 'The MOSS project sequence' chapter.*

The rest of this Introduction is organised under *Alignment design* and *Feature design*.

## Alignment design

An alignment constitutes the basic horizontal and vertical position of a design from which all surface features are generated. For a road the alignment may represent either the centre-line, the channel or any other convenient feature.

Alignments are created in two stages: first the horizontal design, then the vertical design.

For horizontal and vertical design there are three methods;

- the element method
- the intersection point (IP) method
- the cubic spline method

Below is a list of the MOSS design options you can use at each design stage, with the design method most appropriate to it.

### Horizontal design

- ALIGNMENT (element, IP, or cubic spline method)
- HALGN (element method)
- HCUSP (cubic spline)
- DESIGN (simple)

### Vertical design

- ALIGNMENT (element, IP, or cubic spline method)
- VALGN (element method)
- VERAT (IP method)
- VCUSP (cubic splines)
- DESIGN (associated features)

The design methods are described under each major option.

## Feature design

Each alignment may father a series of features related to it essentially by horizontal and vertical offsets.

The DESIGN minor options, which you can access either interactively or with prepared data, create digital strings by reference to other strings. Often the strings are based on the string representation of an alignment.

In MOSS a design model can hold any number of alignments and associated features.

Major option ALIGNMENT enables you to design horizontal and vertical alignments on the screen interactively, using graphics menus to select facilities.



This section consists of the following topics:

- ALIGNMENT features
- The ALIGNMENT design sequence
- Horizontal design
- Vertical design
- Selection methods in ALIGNMENT

ALIGNMENT offers the following facilities:

- Interactive graphical input and display
- Extensive point and data selection methods. Point selection methods (PSMs) enable you to specify points in relation to other information on the screen, and so to relate the design of the current alignment to other alignments or to MOSS strings.
- Fixed, floating and free straights and arcs. Horizontal design using ALIGNMENT employs the element or Intersection Point methods. It involves assembling an alignment from straights, arcs, and transitions if required. Vertical design uses both element and Intersection Point methods. The alignment is assembled from grades and parabolic curves. In both cases you assign the elements fixed, floating or free status.
- Transition definition by several methods (horizontal design)
- Special geometry, such as S-curves and C-curves
- Railway switches
- Automatic development of digital strings
- Comprehensive editing facilities, to modify alignments
- Choice of colours and line styles for the alignment display
- Automatic analysis of alignments, once the data and connections for each element are given
- A special type of model called the Geometry Data Store (GDS) to hold the alignments.
- With major option ALIGNMENT you don't have to design an alignment in any set sequence. Only engineering considerations guide the sequence.

Interactive ALIGNMENT can be used only in graphics mode.

### Alignment representations

There are three distinct representations of every alignment, each appropriate in different circumstances. Each representation is stored on the modelfile.

- The digital form of the alignment is held in a 6D M-string (master string). This is the standard form of string held within the design model and is used for offsetting other strings and for features design.
- The geometry string is a list of the significant points in the alignment from which the geometry at any point may be calculated. These

significant points include; horizontal and vertical tangent points, high and low points, and middle ordinate points. The points in the geometry string are stored in the order of increasing chainage. The geometry strings are held in the design model and are particularly valuable for annotating drawings.

- For each alignment a special form of geometric information is held in the geometry data store, which can only be accessed from within ALIGNMENT.

Both the geometry string and the master string are stored automatically on the design model when the instruction to create an M-string is given in ALIGNMENT.

### Geometry Data Store (GDS)

The GDS is a special type of model and does not contain digital strings like most models, including the design model. The use of the GDS is restricted to ALIGNMENT and is transparent to you the user. GDS models will be small and for the most part you should allow ALIGNMENT to take care of GDS(s) for itself.

We acknowledge its existence here for two reasons:

1. You will be asked to confirm the creation of a new GDS if that required does not exist on entry to ALIGNMENT
2. You will be aware of the existence of GDS(s) from a REPORT 990 list of your model file.

The name of the GDS is the same as the name for your design model but with the letters GDS in characters 26-28 of the field. If the name already occupies these spaces, it will be overwritten with \_GDS there.

The function of the GDS is principally to allow you to start and restart ALIGNMENT jobs as you wish. It is as well not to delete GDS(s) until you are absolutely sure they are no longer required.

ALIGNMENT can restore an alignment to a GDS from the geometry string in the design model. However, although the restored alignment will be correct geometrically, it will assume default values for colours, linestyles and some engineering design parameters. This type of reinstatement should be considered a last resort, and the design parameters in particular should then be checked to ensure they are as required. Generally it is much better to retain the GDS.

### Retrieving an alignment

To reproduce the geometry of an existing M-string so that it may be added to or modified using Interactive Alignment, it is necessary to recreate the GDS, if one does not already exist.

### No GDS

The following procedure may be adopted to retrieve an alignment when there is no GDS associated with the design model containing the master string to be modified.

Enter Interactive Alignment with the master string to be retrieved displayed on the screen. You will then be requested to select the design model using the standard MSM's. You will be shown the prompt 'GDS does not exist: Proceed to create it, Quit to reselect, or Clear. Select Proceed to create an empty GDS model.

To transfer the geometry from the G-string to the GDS, select 'Horizontal design'. The 'Alignment name' box is highlit. Press 'Return' to remove the highlighting and then select 'Retrieve alignment' followed by the master or equivalent geometry string to be retrieved. It is then possible to modify the alignment.

### Existing GDS

The following procedure may be adopted to retrieve an alignment when there is a GDS associated with the design model, but it does not contain the alignment for the master string to be modified.

Enter Interactive Alignment with the master string to be retrieved displayed on the screen. You will then be requested to select the design model using the standard MSM's. The 'Draw alignments' menu is displayed. Draw all the alignments In the GDS and exit the menu. Select 'Horizontal design' followed by 'Create new alignment'. The 'Horizontal design' menu is displayed with the 'Alignment name' box highlit. Press 'Return' to remove the highlighting and then select 'Retrieve alignment' followed by the master or equivalent geometry string to be retrieved.

It is then possible to modify the alignment.

◇ *In both cases, the equivalent vertical alignment is automatically retrieved unless it is already present in the GDS. If this is the case, select Proceed to overwrite the existing vertical alignment or 'Quit' to use the existitng vertical alignment as it is.*

## The ALIGNMENT design sequence

There are three groups of activities within the ALIGNMENT design sequence:

- Start-up
- Design
- Auxiliary functions.

### Overview

#### Start up

- **Create backcloth drawing.**

This activity is outside ALIGNMENT.

To create a backcloth drawing you use major option DRAW. This backcloth drawing will be either a plan or long-section.

- **Specify design model.**

On entry to ALIGNMENT you specify the model in which your digital M-strings will be stored. If it and/or its associated GDS does not exist you will automatically be given the opportunity to create them.

An existing GDS may also be used to restart a job which has been previously worked upon. In this case the Drawing Management option can be used to select which previous alignments are shown on the display.

## Design

- **Design alignment.**

Here you create your alignment, which may be related to existing features or other alignments.

This includes:

- accepting or amending default settings for line styles and colours
- accepting or amending default settings for engineering design parameters, design speeds and transition specifications
- assembling alignments from fixed, floating and free elements
- special geometry such as S-curves, C-curves, and single element alignments
- positioning railway switches

Then you create the horizontal and vertical alignments, which are stored in the associated GDS. When the alignment design is complete you create digital strings from the GDS.

## Auxiliary functions

- **Drawing management:** drawing and erasing alignments as appropriate.
- **Alignment management:** handling alignments within the GDS.
- **Alignment editing:** geometrical manipulation of assembled or partially assembled alignments.
- **Summarising alignments:** displaying intermediate analysis details.
- **Creating M-strings and geometry strings.**

# Major option ALIGNMENT

## Access to major option ALIGNMENT

IGENLT.DAT, GEN004

Design options
ALIGNMENT
H & V alignment design
SECTION
Extraction of sections
DESIGN
Feature strings
INTERFACE
Earthworks design
DRAINAGE
Design and analysis
EDIT
Strings and points
COPY
Copy/move model data
REPORT
Models/strings/points

## Model for ALIGNMENT

IGIADST.DAT, IAD009

Model for ALIGNMENT
Design model

## Access with existing GDS

When you enter major option ALIGNMENT, the 'Drawing management' menu is displayed. This menu is also displayed on specific request from the ALIGNMENT main menu.

With the Drawing Management options you can choose to add to your background drawing some or all of the alignments you have already designed relating to this scheme so that these components may be referenced, copied and manipulated in building up your current alignment.

Refer to 'Drawing Management' for further details.

## Access with blank GDS

When you enter major option ALIGNMENT with a blank GDS the ALIGNMENT main menu is displayed (it is also displayed when leaving ALIGNMENT).

Refer to 'Alignment main menu' for further details.

## ALIGNMENT main menu

IGIADS.DAT, IAD189

ALIGNMENT main menu
Design model
Horizontal design
Vertical design
Superelevation design
Create M-string
Create data output
Drawing management
Alignment management
Delete Geometry Data Store
Exit ALIGNMENT

This menu enables you to progress to the horizontal alignment design (or directly to the vertical alignment design). It also gives access to auxiliary functions - Drawing management and Alignment management.

**Design model:** You may change the design model.

**Horizontal design:** will take you to Horizontal element, Horizontal IP or Horizontal spline design. Before you begin the design you will be asked to confirm whether or not it is a new design. If so, a new GDS will be created.

See the separate section 'Horizontal design' for further details.

**Vertical design:** will take you to either Vertical element, Vertical IP or Vertical spline design.

See the separate section 'Vertical design' for further details.

**Superelevation design:** allows you to apply superelevation to an alignment.

See the separate section 'Superelevation design' for further details.

**Create M-string:** When you have completed a horizontal and/or vertical alignment this option will generate the data to record the alignment in the design model.

See 'Create M-string' for further details.

**Create data output:** You can prepare a file of data based on the ALIGNMENT representation for the non-interactive alignment options HALGN, VALGN and VERAT.

See 'Create data output' for further details.

**Drawing management:** You may draw or erase; all, single, or selected alignments.

See 'Drawing management' for further details.

**Alignment management:** provides facilities to create a parallel alignment, delete, merge or separate alignments or check alignment clearance and invoke the special features included within ALIGNMENT for junction design.

See 'Alignment management' for further details.

**Delete Geometry Data Store:** When you are certain that a GDS is no longer required, use this option rather than major option DELETE.

You can end an interactive session in MOSS major option ALIGNMENT at any stage, without completing either your horizontal or vertical design, and the current data for all alignments will be stored on the GDS.

## Create M-string

Creates a master string and a geometry string from an existing alignment.

IGIADST.DAT, IAD191

Create M string
Alignment
Chainage interval
Transition ch interval
Chord to arc tolerance
Datum point X
Y
New chainage at datum
Draw M-string (T)

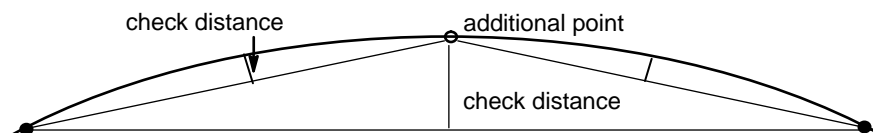
**Alignment** is the name of the alignment to be converted to a master and a geometry string.

**Chainage interval** defines the interval at which points are spaced along the master string. The default chainage interval is set using CRMCHINT in the parameter file.

**Transition chainage** interval defines the interval at which points are spaced along transitions in the master string. The default transition chainage interval is set using CRMTRINT in the parameter file.

**Chord to arc tolerance** is the maximum distance allowed between the chord and arc connecting adjacent string points.

When the new master string is created, points are generated at the specified chainage interval and the chord to arc distance is checked against the specified tolerance. If the tolerance is exceeded further points are introduced until the tolerance is satisfied.



**Figure 6 - 1 Chord to arc tolerance**

**Datum point X, Y** are the coordinates of the point used as the chainage datum.

**New chainage at datum** is the value of the chainage at the datum point.

**Draw M-string** displays the master string upon creation if the toggle is set to Yes.



The M-string can only be displayed if the current sheet is a plan drawing. If the current sheet is a longsection and Draw M-string is toggled to Yes, a warning message will be displayed.

## Create data output

IGIADST.DAT, IAD292, IAD194

Data output menu	HALGN output
Create HALGN data	Alignment name
Create VALGN data	Non standard alignment (T)
Create VERAT data	.INP file name

◇ *Similar menus are displayed for both VALGN and VERAT data.*

### Create HALGN data

You can prepare a file of data based on the ALIGNMENT representation for the batch process program HALGN using this facility. The data will be placed in a named file of suffix .INP for subsequent entry to HALGN.

Standard alignment provides an output in which the elements are in the sequence of creation in the alignment.

Non-standard alignment provides an output which is an interpretation of the alignment elements in the sequence start to end.

The data within this file represents the alignment with the first element fixed and all further elements floated.

There may be small differences due to rounding between a master string developed in alignment and a master string developed by running HALGN on a data file created by this function.

Default chainage intervals are defined in the parameter file.

- ◇ *HALGN data can be generated from Horizontal IP type alignments but will not contain the intersection point(s) data.*
- ◇ *Alignments with arcs which subtend more than 90 degrees at their centre will need manual editing to remove ambiguities in the .PRN fix. You will be warned if this occurs.*

### Create VALGN data

You can prepare a file of data based on the ALIGNMENT representation for the batch process program VALGN using this facility. The data will be placed in a named file of suffix .INP for subsequent entry to VALGN.

Standard alignment provides an output in which the elements are in the sequence of creation in the alignment.

Non-standard alignment provides an output which is an interpretation of the alignment elements in the sequence start to end.

The data within this file represents the alignment with the first element fixed and all further elements floated.

There may be small differences due to rounding between a master string developed in alignment and a master string developed by running VALGN on a data file created by this function.

- ◇ *A VALGN data file can be generated from an Intersection Point Alignment but will not contain the intersection point(s) data.*

### Create VERAT data

You can prepare a file of data based on the ALIGNMENT representation for the batch process program VERAT using this facility. The data will be placed in a named file of suffix .INP for subsequent entry to VERAT.

The data within this file represents the alignment with the first element fixed and all further elements floated in sequence.

There may be small differences due to rounding between a master string developed in alignment and a master string developed by running VERAT on a data file created by this function.

- ◇ *A VERAT data file can only be generated from a Vertical Alignment which follows the sequence Grade/Curve/grade/curve.*

## Drawing management

IGIADS.DAT, IAD091

Alignment drawing
Draw all alignments
Draw selected alignments
Draw single alignment
Erase all alignments
Erase selected alignments
Erase single alignment
Exit this menu

You can choose to add to your background drawing some or all of the alignments you have already designed related to this scheme. The benefit of this is that you can reference, copy and manipulate these previously designed components when building up your current alignment.

If you select **Draw all alignments** then all the alignments which are currently in your GDS will be drawn. They will appear in the background colour and style chosen for each alignment.

You may well have numerous alignments in your GDS and only wish to access those having a direct influence. When you **Draw selected alignments** a list will be given in the scrolling menu area. Select those you wish to draw.

If you know the alignment you wish to draw you can **Draw single alignment** and supply the name.

The direct converse of drawing alignments is to erase them and this applies to **Erase all alignments**, **Erase selected alignments**, and **Erase single alignment**. This erasure only deletes from the picture; the alignments are still in the GDS for re-use if required.

All the alignments made active by drawing them are drawn in their background colour and style. If you want to change these background properties you can toggle the alternatives of **Background align colour** or **Background align style** in the 'Display parameters' menu.

- ◇ *Any alignments added to the background drawing will be drawn in the form they were in when they were last accessed.*
- ◇ *The alignment representation drawn is stored the GDS and need not be fully designed.*

- ◇ *Once drawn the data related to the elements in the GDS may be accessed and used in the current design.*
- ◇ *With an automatic section, only the appropriate alignments will be drawn.*

## Alignment management

IGIADS.DAT, IAD085

Alignment management
Parallel alignment
Delete alignment
Merge alignments
Separate alignment
Clearance
Associate alignments
Dissociate alignments
Delete superelevation
Define chainage datum
Exit this menu

Alignment management can apply either to horizontal design or to vertical design.

**Delete superelevation** deletes all crossfall or cant values which have been applied to an alignment.

For further details of superelevation, refer to 'Superelevation design'.

## Parallel alignment

IGIADS.DAT, IAD085, IAD086

Alignment management	Parallel alignment
Parallel alignment	Originating alignment
Delete alignment	Parallel alignment name
Merge alignments	Offset (T)
Separate alignment	
Clearance	
Associate alignments	
Dissociate alignments	
Delete superelevation	
Define chainage datum	
Exit this menu	

You can use **Parallel alignment** to amend a completed alignment to accommodate more up to date knowledge, or you can keep the designed alignment in its original form and take a copy which can then be modified. Select the alignment to be copied, either by selecting using the cursor or by giving the name. You must also give the name of the new alignment. If your alignment has no transitions it can be copied with a parallel offset applied. If there are transitions then, to include an offset, you must copy the constituent elements and then redesign the transition lengths. This technique protects against invalid transition definitions. For further information on transitions, refer to Chapter 7, Major option HALGN.

## Delete alignment

IGIADS.DAT, IAD085

<b>Alignment management</b>
Parallel alignment
<b>Delete alignment</b>
Merge alignments
Separate alignment
Clearance
Associate alignments
Dissociate alignments
Delete superelevation
Define chainage datum
Exit this menu

With this facility, if an alignment becomes redundant you can select it and delete it directly from the GDS. Alternatively, you may type the name of the alignment to be deleted from the keyboard.

If a plan drawing is displayed (ie, a horizontal alignment):

- Type the full or horizontal alignment name to delete both the horizontal and its associated vertical alignment (eg, MAST or HAST).
- Type the vertical alignment name to delete the vertical alignment only (eg, VAST).
- Select the alignment to delete both the horizontal and vertical alignment.

If a profile drawing is displayed (ie, a vertical alignment), only the vertical alignment is deleted whichever method is used to specify the alignment.

## Merge alignment

IGIADS.DAT, IAD085, IAD088

Alignment management	Merge alignment
Parallel alignment	Primary alignment
Delete alignment	Merging alignment
Merge alignments	
Separate alignment	
Clearance	
Associate alignments	
Dissociate alignments	
Delete superelevation	
Define chainage datum	
Exit this menu	

**Merge alignment:** enables two alignments that have been designed separately within major option ALIGNMENT to be joined to form a continuous alignment.

First you select the two alignments to be joined, and they are then grouped under the name of the first (the second is deleted). In this, the colours, other attributes, and design parameters of the second are changed to those of the first. Then the two (or more) part alignments in the first alignment can be joined by free elements (or whatever) in the usual way.

## Separate alignments

IGIADS.DAT, IAD085, IAD014

Alignment management	Separate part-alignment
Parallel alignment	Alignment
Delete alignment	Receiving alignment
Merge alignments	Start point X
Separate alignment	Y
Clearance	End point X
Associate alignments	Y
Dissociate alignments	Original (T)
Delete superelevation	
Define chainage datum	
Exit this menu	

**Separate part-alignment:** This facility separates an alignment into two parts. Give the alignment to be separated and also give the names of the alignments created. If you do not specify the second name then the original alignment will be modified to include the gap left by removing the separated portion.

## Clearance checking

IGIADS.DAT, IAD085, IAD008

Alignment management	Clearance checking
Parallel alignment	Check pt X
Delete alignment	Y
Merge alignments	Distance to alignment
Separate alignment	Align point X
Clearance	Y
Associate alignments	
Dissociate alignments	
Delete superelevation	
Define chainage datum	
Exit this menu	



**Clearance checking:** evaluates the minimum clearance between the alignment and a specified point.

From the check point you specify the distance to coordinates of the nearest portion on the alignment is evaluated.

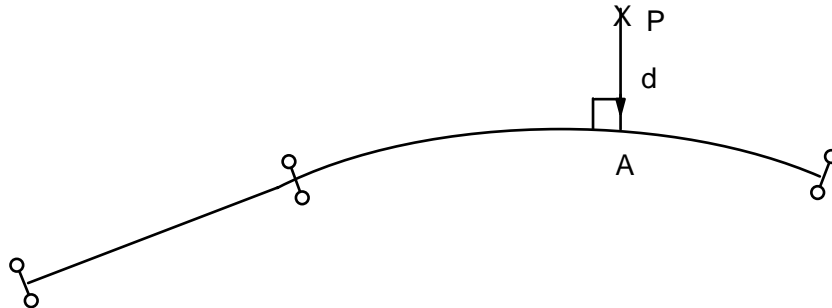


Figure 6 - 2 Example - clearance

In the diagram the closest position to point P on the alignment is point A, along the normal. Clearance reports the coordinates of A together with the distance d between P and A.

## Define chainage datum

Allows you to set up a non-zero chainage datum for a horizontal alignment.

IGIADS.DAT, IAD085, IAD354

Alignment management	Define chainage datum
Parallel alignment	Alignment
Delete alignment	Datum point X
Merge alignments	Y
Separate alignment	New chainage at datum
Clearance	
Associate alignments	
Dissociate alignments	
Delete superelevation	
Define chainage datum	
Exit this menu	

**Alignment** is the name of the alignment for which the new chainage datum is to be set.

**Datum point X/Y** allows you to specify the location of the new chainage datum.

If the datum point has already been set, the coordinates shown are the coordinates of the first point on the alignment, not those of the datum point.

**New chainage at datum** allows you to set the chainage value at the datum.

If the datum point has already been set, the chainage shown is the chainage at the first point on the alignment, not that of the datum point.

## Status

Use of the STATUS box in the static menu area whilst using ALIGNMENT will invoke a menu which gives immediate access to the special status options available to ALIGNMENT. This menu gives you the opportunity to revert to the non-ALIGNMENT status options if you wish.

ALIGNMENT status options are available for both horizontal and vertical alignments and allow you to interrogate alignments.

You may also obtain information from fixed elements before they become links.

## Input

### Graphics

IGIADS.DAT, IAD176, IAD177

Horizontal alignment
Point information
Element information
Link information
Plan length information
Slope length information
Superelevation information
Statistics report
Non alignment status
Output to a file
Alignment diagnostics

◇ *This menu will be displayed if you are in horizontal alignment. A similar menu is displayed if you are in vertical alignment.*

## Horizontal and vertical

The functionality of horizontal and vertical status is broadly similar although values appropriate to the phase of design are output.

**IGIADS.DAT, IAD178, IAD184**

**Point information:** This enables you to select any tangent point on an alignment and to receive details of its position and that of the elements which abut the tangent point.

**IGIADS.DAT, IAD240, IAD241, IAD242, IAD243**

**Element information:** This enables you to select any fixed element of an alignment before it has become a link and receive details of its geometry.

**IGIADS.DAT, IAD179, IAD180, IAD181, IAD185**

**Link information:** This enables you to select any link on an alignment and receive details of its geometry.

**IGIADS.DAT, IAD182, IAD188**

**Plan length information:** This enables display of chainage difference between any 2 tangent points in an alignment to be displayed. The points must be on the same alignment and must not be separated by a gap in that alignment.

**IGIADS.DAT, IAD244**

**Slope length information:** This enables display of the calculated slope length between any 2 points in an alignment to be displayed. For details of the formula and other limitations, see page 6 - 189.

**IGIADS.DAT, IAD183, IAD187, IAD190, IAD192, IAD157, IAD162**

**Statistics report:** This shows complete details of a chosen alignment including extreme values of radii, curve parameters and transition constants. For alignments of several parts there is the option to report statistics for each of the parts.

**Non ALIGNMENT status:** This gives access to the non-Alignment specific status.

**Alignment diagnostics:** Creates a formatted file containing the details of your alignment. The file is named 'draw.mif' by default but you are given the option to rename the file on exit from MOSS.

### Horizontal only

**IGIADS.DAT, IAD348, IAD349, IAD350, IAD351, IAD352, IAD353**

**Superelevation information:** This shows cant or crossfall values applied to a straight, an arc or a transition, together with the units used when the values were stored.

**IGIADS.DAT, IAD100**

**Output to a file:** This enables you to select an alignment and write details of its tangent points to a named file.

## Superelevation design

Applies superelevation to an alignment using a general method. The superelevation is stored on the geometry string as either crossfall or cant, and may be used to calculate transition lengths or to design channel or rail strings.

Superelevation can also be applied to an alignment automatically if national design rules are in force. For example, railway alignments designed to Dutch design standards have superelevation applied automatically to facilitate the design of rail strings.

- ◇ *The general method described here cannot be used for alignments designed using Dutch transition design rules.*
- ◇ *In superelevation design, crossfall or cant menus are displayed according to the type of superelevation being applied. Documentation for the crossfall menus is included only.*

IGIADS.DAT, IAD189, IAD320

ALIGNMENT main menu	Superelevation design
Design model	Alignment name
Horizontal design	Superelevation (T)
Vertical design	Superelevation parameters
Superelevation design	Display parameters
Create M-string	
Create data output	
Drawing management	
Alignment management	
Delete Geometry Data Store	
Exit ALIGNMENT	

**Alignment name** is the name of the alignment to which superelevation is to be applied.

**Superelevation** is a toggle which determines whether superelevation is stored as cant or crossfall.

If crossfall or cant has already been applied to this alignment, then the same superelevation type must be applied.

**Superelevation parameters** allows you to set up various parameters for crossfall or cant, for example, units, minimum and maximum values, etc.

**Display parameters** allows you to set up display parameters such as the applied superelevation colour.

Select Proceed to apply crossfall or cant to the specified alignment.

- ◇ *To delete the superelevation applied to an alignment, use 'Delete superelevation' from the 'Alignment management' menu.*

## Crossfall parameters

Sets up parameters for the application of crossfall to an alignment.

IGIADS.DAT, IAD321 / IAD322 / IAD323

Crossfall parameters
Crossfall units (T)
Theoretical crossfall (T)
Design speed [V]
Theoretical factor [K]
Rounding (T)
To
Min crossfall
Max crossfall
Inflection crossfall
Reset params to default

**Crossfall units** is a toggle which can be either a percentage (%), a decimal percentage (dec %) or a ratio (1:n).

**Theoretical crossfall** is a toggle which determines whether a theoretical value of crossfall is to be applied by the system according to the formula:

$$S_T = \frac{V^2}{KR}$$

where:

$S_T$  = theoretical crossfall

$V$  = design speed

$K$  = theoretical factor

$R$  = radius of curve

**Design speed [V]** is the speed used in the above equation to calculate the theoretical crossfall.

**Theoretical factor [K]** is the factor used in the above equation to calculate the theoretical crossfall.

**Rounding** is a toggle which allows the theoretical crossfall to be rounded either up, down or to the nearest factor given in the next menu field (**To**). For example, if 'Rounding' is toggled to 'nearest' and 'To' is set to 0.005, a theoretical crossfall of 0.056 will be rounded to 0.055.

**Minimum crossfall** is the default value of crossfall applied to straight elements.

**Maximum crossfall** is the maximum value of crossfall that can be applied to curved elements.

**Inflection crossfall** is the minimum value of crossfall to be applied where back to back transitions of opposite hand exist.

**Reset parameters to default** resets the crossfall parameters to those defined in the parameter file.

- ◇ *The default values for the crossfall parameters are stored in the parameter file.*

## Display parameters

Sets up display parameters for superelevation design.

IGIADS.DAT, IAD356

Display parameters
Applied superelevation (T)

**Applied superelevation** is a toggle which allows you to select the colour in which links are displayed when superelevation has been applied.

## Apply crossfall

Applies crossfall to a specified alignment. Crossfall may be applied to all links in an alignment, to each link in turn (sequentially) or to a single link.

IGIADS.DAT, IAD324 / IAD325 / IAD338 / IAD339 / IAD340 / IAD341

Apply crossfall
All links
Sequential links
Single link
Inflection point
Amend parameters
Display links in error
Sequential links in error
Review crossfall
End apply crossfall

**All links** allows you to apply a theoretical crossfall value to every link in a selected part of an alignment. To use this method, 'Theoretical crossfall' should be applied in the 'Crossfall parameters' menu.

When you select this field, a menu is displayed which allows you to specify the range of application of crossfall. From this menu, select Proceed to apply crossfall to the specified range.

If no crossfall is in error, the alignment links are redrawn in the applied superelevation colour as defined in 'Display parameters'.

If any of the crossfall is in error, the 'Crossfall in error' menu is displayed. Here, you may accept the crossfall, abandon the crossfall or amend the crossfall on those links which are in error.

**Sequential links** allows you to apply crossfall to each link in turn of a selected part of an alignment. If you are applying theoretical crossfall, you are prompted to confirm the rounded theoretical value for each link. Otherwise, you should input a crossfall value for each link from the keyboard.

As each link is considered, a menu is displayed which is dependent upon the type of link, ie, straight, arc, C curve or S curve.

When you have applied the crossfall to a link, if it is not in error, the link is redrawn in the applied superelevation colour. Otherwise, a 'Crossfall in error' menu is displayed, where you may accept the crossfall, abandon the crossfall or respecify the crossfall for this link.

**Single link** allows you to apply crossfall to a single link in an alignment.

When you select this field, a menu is displayed which allows you to specify the link to which crossfall is applied.

**Inflection point** allows you to apply crossfall at points of inflection and 'C' curves.

When you select this field, a menu is displayed which allows you to specify the point at which crossfall is applied.

**Amend parameters** allows you to modify the crossfall parameters.

**Display links in error** allows you to highlight the links in the alignment which are in error.

**Sequential links in error** allows you to re-apply crossfall to each link which is in error. The menu sequence is the same as that for 'Sequential links' except that only links in error are amended.

**Review crossfall** allows you to review the links to which crossfall has been applied so far.

**End apply crossfall** returns you to the 'Superelevation design' menu.

◇ *Links in error are those links whose crossfall values lie outside the range specified in the crossfall parameters.*

## All/sequential crossfall

Defines the start and end of the range of crossfall application on an alignment.

IGIADS.DAT, IAD330 / IAD331 / IAD332 / IAD333

All crossfall	
Start point	X
	Y
End point	X
	Y

**Start point X/Y** defines the point on the alignment at which crossfall application is to start.

**End point X/Y** defines the point on the alignment at which crossfall application is to end.

If you wish to apply crossfall along the whole alignment, leave the fields blank and select Proceed.



## Apply crossfall: arc

Applies crossfall to an arc.

IGIADS.DAT, IAD334 / IAD335

Apply crossfall: arc
Alignment element name
Crossfall units (R)
Radius (R)
Design speed
Theoretical crossfall (R)
Rounded crossfall

**Alignment element name** is the label of the arc to which crossfall is applied.

**Crossfall units** shows the units of the applied crossfall.

**Radius** shows the radius of the arc.

**Design speed** shows the design speed as set in the crossfall parameters menu which is used to calculate the theoretical crossfall. You may override this design speed if you wish, and if theoretical crossfall is being applied, the value shown in the next field is automatically updated.

**Theoretical crossfall** shows the theoretical crossfall as derived from the current crossfall parameters and the design speed shown in the previous field.

**Rounded crossfall** allows you to specify the crossfall to be applied to the arc. If you are applying theoretical crossfall values, you can use this field to override the theoretical value.

Select Proceed to apply the crossfall to the arc.

Select Quit to leave this menu without applying crossfall and to return to the previous menu.

◇ *Any subsequent transition will also take the superelevation value applied to the arc.*

## Apply crossfall: straight

Applies crossfall to a straight.

IGIADS.DAT, IAD336 / IAD337

Apply crossfall: straight
Alignment element name
Crossfall units (R)
Design speed
Crossfall

**Alignment element name** is the label of the straight to which crossfall is applied.

**Crossfall units** shows the units of the applied crossfall.

**Design speed** shows the design speed as set in the crossfall parameters menu. You may override this design speed if you wish.

**Crossfall** allows you to specify the crossfall to be applied to the straight. If you are applying theoretical crossfall values, the default value shown in the menu is the minimum crossfall specified in 'Crossfall parameters'.

Select Proceed to apply the crossfall to the straight.

Select Quit to leave this menu without applying crossfall and to return to the previous menu.

◇ *Any subsequent transition will also take the superelevation value applied to the straight.*

## Apply crossfall: C-curve

Applies crossfall to a C curve.

IGIADS.DAT, IAD342 / IAD343

Apply crossfall: C-curve
Alignment element name
Crossfall units (R)
Radius (R)
Design speed
Theoretical crossfall (R)
Rounded crossfall

**Alignment element name** is the label of the C-curve to which crossfall is applied.

**Crossfall units** shows the units of the applied crossfall.

**Radius** shows the radius of the C-curve.

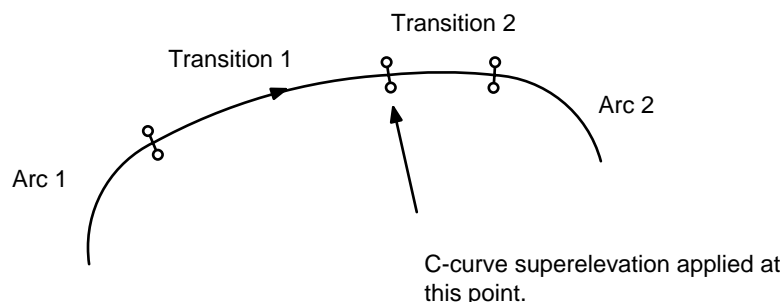
**Design speed** shows the design speed as set in the crossfall parameters menu which is used to calculate the theoretical crossfall. You may override this design speed if you wish, and if theoretical crossfall is being applied, the value shown in the next field is automatically updated.

**Theoretical crossfall** shows the theoretical crossfall as derived from the current crossfall parameters and the design speed shown in the previous field.

**Rounded crossfall** allows you to specify the crossfall to be applied to the C-curve. If you are applying theoretical crossfall values, you can use this field to override the theoretical value.

Select Proceed to apply the crossfall to the C-curve.

Select Quit to leave this menu without applying crossfall and to return to the previous menu.



**Figure 6 - 3 Superlevation applied to a C-curve**

In Figure 6 - 3, transition 1 takes on the superelevation applied to arc 1 and transition 2 takes the superelevation value applied to the C-curve.

## Apply crossfall: S-curve

Applies crossfall to an S-curve.

IGIADS.DAT, IAD344 / IAD345

Apply crossfall: S-curve
Alignment element name
Crossfall units (R)
Design speed
Crossfall

**Alignment element name** is the label of the S-curve to which crossfall is applied.

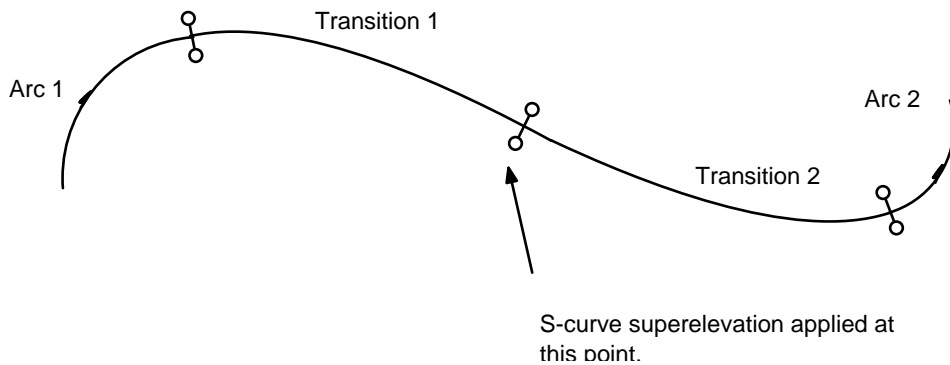
**Crossfall units** shows the units of the applied crossfall.

**Design speed** shows the design speed as set in the crossfall parameters menu. You may override this design speed if you wish.

**Crossfall** allows you to specify the crossfall to be applied to the S-curve. If you are applying theoretical crossfall values, the default value shown in the menu is the minimum crossfall specified in 'Crossfall parameters'.

Select Proceed to apply the crossfall to the S-curve.

Select Quit to leave this menu without applying crossfall and to return to the previous menu.



**Figure 6 - 4 Superelevation applied to a S-curve**

In Figure 6 - 4, transition 1 takes on the superelevation applied to arc 1 and transition 2 takes the superelevation value applied to the S-curve.

### Crossfall in error: all

Reviews the links in an alignment whose crossfalls are in error. All links which are in error are displayed in the highlight colour.

- ◇ *Links in error are those links whose crossfall values lie outside the range specified in the crossfall parameters.*

IGIADS.DAT, IAD326 / IAD327

Crossfall in error : all
No. of links in error (R)
Display links in error
Amend crossfall in error
Abandon all crossfall
Accept all crossfall

**No. of links in error** is the number of links which have been found to be in error (for information only).

**Display links in error** allows you to highlight the links in the alignment which are in error.

**Amend crossfall in error** allows you to correct the crossfall on the links in error.

If you correct the crossfall, you are taken through each link in error sequentially. As each link is considered, a menu is displayed which is dependent upon the type of link, ie, straight, arc, C curve or S curve. To correct the link, amend the crossfall value and select Proceed to display the menu for the next link in error.

If you correct the crossfall on a link, but the value you specify still lies outside the range specified in the crossfall parameters, the menu 'Crossfall in error: single' is displayed. You may then accept, amend or abandon the crossfall on the link.

**Abandon all crossfall** discards all the crossfall applied to this alignment and returns you to the 'Apply crossfall' menu.

**Accept all crossfall** accepts the crossfall applied to all links (even those which have been found to be in error) and stores the values on the GDS. You are then returned to the 'Apply crossfall' menu.

### Crossfall in error: single

Reviews a link in an alignment whose crossfall is in error. The link is displayed in the highlight colour.

- ◇ *Links in error are those links whose crossfall values lie outside the range specified in the crossfall parameters.*

IGIADS.DAT, IAD328, IAD329

Crossfall in error : single
Amend crossfall in error
Abandon crossfall
Accept crossfall

**Amend crossfall** allows you to correct the crossfall on the link.

**Abandon crossfall** discards the crossfall applied to this link and returns you to the 'Apply crossfall' menu.

**Accept crossfall** accepts the crossfall applied to the link (even though it has been found to be in error) and stores the value on the GDS. The link is redrawn in the 'applied superelevation' colour and you are then returned to the 'Apply crossfall' menu.

## Crossfall review

Reviews the crossfalls applied to links in an alignment.

IGIADS.DAT, IAD346 / IAD347

<b>Crossfall review</b>
<b>Applied crossfall (R)</b>
<b>No. of links (R)</b>
<b>No. of links analysed (R)</b>
<b>No. of links in error (R)</b>
<b>Display links in error</b>

**Applied crossfall** indicates whether the applied crossfall is OK or in error. If the crossfall is in error, the crossfall does not lie within the limits imposed by the crossfall parameters.

**No. of links** is the total number of links in the selected alignment (for information only).

**No. of links analysed** is the number of links which have been analysed.

**No. of links in error** is the number of links which have been found to be in error.

**Display links in error** allows you to highlight the links in the alignment which are in error.

# Horizontal design

## Introduction

This section takes you through the process of horizontal design using major option ALIGNMENT.

There are three methods for designing alignments:

- the element method
- the intersection point (IP) method
- the cubic spline method

In the **element** method you assemble fixed, floating and/or free straights and circular arcs into an alignment in any sequence. Transition curves may be included in the sequence.

In the **IP** method you build the horizontal alignment as a sequence of straight-arc-straight-arc, and so on. As with the element method, transition curves may be included in the sequence.

In the **cubic spline** method you locate points to define a curve and then analyse the points to produce a spline.

Each of the three design methods is described separately.

- ◇ *A maximum of 500 elements (element or IP method) or location points (spline method) may be used in any single alignment.*

## Continue alignments

You get this menu in two circumstances:

- On entry to horizontal or vertical design with an existing GDS. Basically this is to allow you to select which of the alignments on the GDS to modify or enhance in some way.
- On ending the current alignment.



IGIADST.DAT, IAD097

Continue alignments
Continue old alignment
Create new alignment
Exit this menu

**Continue old alignment** allows you to modify an alignment which already exists in the GDS.

**Create new alignment** allows you to start a new alignment and add it to the existing GDS.

## Horizontal design

IGIADST.DAT, IAD298

Horizontal design
Alignment name
Design method (T)
Background colour (T)
Display parameters
Design parameters
Retrieve alignment

**Alignment name** is the name of the alignment to be designed or modified.

You must give an alignment a four-character name starting with any letter. However, the first character will always be replaced by M, and the resulting name will be that under which the master string generated from major option ALIGNMENT will be stored.

As ALIGNMENT progresses it uses internal names for alignments, in which the M is replaced by H for horizontal alignments and V for vertical alignments. These names are sometimes displayed in the Scrolling Menu Area (SMA).

Also an alignment called, say, M001 will have an equivalent reference in each of the associated models:

Alignment name	M001
M-string (when created)	M001 Design Model
Geometry string (when created)	G001 Design Model
Known to horizontal alignment as	H001 GDS
Known to vertical alignment as	V001 GDS

While you are in ALIGNMENT you will only be working with the GDS representation. The M-string and geometry strings are only created when you are ready to go on to feature design.

You can enter and leave ALIGNMENT without having created an M-string, working only with the GDS.

**Design method** is a toggle which allows you to select one of the three methods of design if you are creating a new alignment. However, depending upon the circumstances when you select the toggle, some restrictions may be imposed.

For example, if you are modifying an existing spline alignment, an (R) is displayed instead of the toggle to indicate that the field is read-only, ie, an existing spline alignment may only be modified using the spline method.

**Background colour** is the colour in which the alignment is displayed when it is not the current alignment. This facility is particularly useful in preparing preliminary designs, where you can have a red route, a green, and so on.

The colour you specify here as the background colour becomes the default. In other words, the background colour field in the 'Display parameters' menu is also updated to reflect the colour you choose here.

**Display parameters** allows you to check or modify the default display parameters used in ALIGNMENT. There is a separate set of parameters for each method of design in ALIGNMENT. Refer to 'Display parameters' in the appropriate section for more information.

**Design parameters** allows you to check or modify the default design parameters used in ALIGNMENT. There is a separate set of parameters for each method of design in ALIGNMENT. Refer to 'Design parameters' in the appropriate section for more information.

**Retrieve alignment** allows you to create an alignment from a geometry string so that it can be modified.

On entry to this menu, 'Alignment name' is autohighlighted. Press Return to remove the autohighlighting and select 'Retrieve alignment'. You may now

select the master or geometry string to be retrieved from the screen or you may type the name of the string using the keyboard.

The alignment is displayed when it is created. You may amend the design or the display parameters if required before you continue with the alignment design.

The equivalent vertical alignment is automatically retrieved unless it is already present in the GDS. If this is the case, select Proceed to overwrite the existing vertical alignment or 'Quit' to use the existing vertical alignment as it is.

# Horizontal element method

## Introduction

This section takes you through the process of horizontal design using the element method. Using this method you assemble fixed, floating and/or free straights and circular arcs into an alignment in any sequence.

Some general information about using the horizontal element method is given below.

### Point selection

There are several methods of selecting the points to include in your alignment analysis, and these are described in the Alignment section 'Selection Methods'.

### Chainages

When fixing elements, all chainages are local. As a sequence of elements is combined, the program automatically reassigns chainages. Later when you derive your M-string you can choose the chainage datum point and assign a chainage value to it.

### Joining fixed elements

If there are two adjacent fixed elements each will be fixed independently of the other and an iterative method derives the required transition between the two elements. There are additionally some special fix-to-fix geometric arrangements and these are described under *Specials*.

### Selection of solution for free arcs

If the solution chosen by the program is wrong for a free curve then use the *Solution* toggle to calculate the alternative solution (but first check you are using the correct hand of curve).

## Element alignment

IGIADS.DAT, IAD034a, IAD034b

Element alignment
Fix straight
Fix arc
Float str
Float arc
Free straight
Free arc
Add straight
Add arc
Edit alignment
Specials
Clearance checking
Amend design parameters
End this alignment

**Element alignment** is the menu at the head of a family of menus by which you calculate the position of the elements in your alignment.

If you were designing an alignment manually, linking straights and circular arcs with transitions, you would sketch out your alignments initially on a plan with railway curves. With ALIGNMENT, instead of the backcloth paper drawing, you have the backcloth drawing on your workstation. You then position your arcs and straights with varying degrees of fixity until you feel you have the required solution. The program automatically computes the arithmetic and displays the geometry superimposed on your drawing.

There are three ways of specifying the geometric elements of a conventional alignment of straights and circular arcs linked together with transitions. With each of these, the elements are referred to as being either fixed, floating or free.

- **Fixed elements.** A fixed element is fully defined in position by the geometric information used in its specification. For example, a curve defined as passing through three distinct points is uniquely defined and is considered a fixed element.
- **Floating elements.** A floating element is defined so that it has one degree of freedom. The element becomes fully defined by connecting it to an adjacent element in the alignment. For example, a floating straight defined as passing through a point would be rotated until it is tangential to an adjacent curve.
- **Free elements.** A free element is defined so that it has two degrees of freedom. The location of the element is resolved by considering the geometric elements to either side of it. For example, the centre

coordinates of a circle which has only its radius explicitly given will be moved until the circle is tangential to the elements either side of it.

As you enter each floating or free element ALIGNMENT analyses the part of the alignment connected to the floating or free element.

One point worth noting is that you don't have to begin at the beginning of the alignment and proceed in the direction of increasing chainage. Also, an alignment can consist of several part-alignments, although they must be joined to form a wholly-continuous alignment before a master string can be generated.

**Add straight** is used to append a straight element to an arc.

**Add arc** is used to append an arc to a straight.

**Edit alignment** is at the head of a family of menus which allow you to edit an existing alignment.

**Specials** takes you to a menu which contains special cases of alignment geometry.

**Clearance checking** is used to check the shortest distance between a specified point and an alignment.

**Amend parameters** returns you to the 'Horizontal design' menu. From 'Horizontal design', you may change the display or the design parameters, as well as the design method (within certain restrictions). Select Quit or Proceed to return to the 'Element alignment' menu.

**End this alignment** ends the current alignment and returns you to the 'Continue alignments' menu.

## Define fix straight

### Fix straight: 2 points

IGIADS.DAT, IAD034, IAD001, IAD016

Element alignment	Define fix straight	Fix straight: 2 points
Fix straight	Through 2 points	Alignment element name
Fix arc	Through point and bearing	Point 1 X
Float str	Copy alignment element	Y
Float arc		Point 2 X
Free straight		Y
Free arc		
Add straight		
Add arc		
Edit alignment		
Specials		
Clearance checking		
Amend design parameters		
End this alignment		

### Fix straight: point and bearing

IGIADS.DAT, IAD034, IAD001, IAD017

Element alignment	Define fix straight	Fix straight: point & brg
Fix straight	Through 2 points	Alignment element name
Fix arc	Through point and bearing	Point X
Float str	Copy alignment element	Y
Float arc		Bearing
Free straight		
Free arc		
Add straight		
Add arc		
Edit alignment		
Specials		
Clearance checking		
Amend design parameters		
End this alignment		

## Define fix arc

### Fix arc: 3 points

IGIADS.DAT, IAD034, IAD002, IAD024

Element alignment	Define fix arc	Fix arc: 3 points
Fix straight	Through 3 points	Alignment element name
Fix arc	Through 2 points & radius	Point 1 X
Float str	Centre & radius	Y
Float arc	Centre & through point	Point 2 X
Free straight	Through 2 pts and bearing	Y
Free arc	Through pt, radius & brg	Point 3 X
Add straight	Through 2 pts on diameter	Y
Add arc	Through 3 tangents	
Edit alignment	Copy alignment element	
Specials		
Clearance checking		
Amend design parameters		
End this alignment		

### Fix arc: 2 points and radius

IGIADS.DAT, IAD034, IAD002, IAD025

Element alignment	Define fix arc	Fix arc: 2 points & radius
Fix straight	Through 3 points	Alignment element name
Fix arc	Through 2 points & radius	Point 1 X
Float str	Centre & radius	Y
Float arc	Centre & through point	Point 2 X
Free straight	Through 2 pts and bearing	Y
Free arc	Through pt, radius & brg	Radius
Add straight	Through 2 pts on diameter	Hand of arc (T)
Add arc	Through 3 tangents	
Edit alignment	Copy alignment element	
Specials		
Clearance checking		
Amend design parameters		
End this alignment		



## Fix arc: centre and radius

IGIADS.DAT, IAD034, IAD002, IAD026

Element alignment	Define fix arc	Fix arc: centre & radius
Fix straight	Through 3 points	Alignment element name
Fix arc	Through 2 points & radius	Centre X
Float str	Centre & radius	Y
Float arc	Centre & through point	Radius
Free straight	Through 2 pts and bearing	Hand of arc
Free arc	Through pt, radius & brg	
Add straight	Through 2 pts on diameter	
Add arc	Through 3 tangents	
Edit alignment	Copy alignment element	
Specials		
Clearance checking		
Amend design parameters		
End this alignment		

## Fix arc: centre and point

IGIADS.DAT, IAD034, IAD002, IAD027

Element alignment	Define fix arc	Fix arc: centre & point
Fix straight	Through 3 points	Alignment element name
Fix arc	Through 2 points & radius	Centre X
Float str	Centre & radius	Y
Float arc	Centre & through point	Point X
Free straight	Through 2 pts and bearing	Y
Free arc	Through pt, radius & brg	Hand of arc (T)
Add straight	Through 2 pts on diameter	
Add arc	Through 3 tangents	
Edit alignment	Copy alignment element	
Specials		
Clearance checking		
Amend design parameters		
End this alignment		

## Fix arc: 2 points and bearing

IGIADS.DAT, IAD034, IAD002, IAD028

Element alignment	Define fix arc	Fix arc: 2 points & brg
Fix straight	Through 3 points	Alignment element name
Fix arc	Through 2 points & radius	Point 1 X
Float str	Centre & radius	Y
Float arc	Centre & through point	Point 2 X
Free straight	Through 2 pts and bearing	Y
Free arc	Through pt, radius & brg	Bearing at point 2
Add straight	Through 2 pts on diameter	
Add arc	Through 3 tangents	
Edit alignment	Copy alignment element	
Specials		
Clearance checking		
Amend design parameters		
End this alignment		

## Fix arc: radius, point and bearing

IGIADS.DAT, IAD034, IAD002, IAD029

Element alignment	Define fix arc	Fix arc: pt, radius & brg
Fix straight	Through 3 points	Alignment element name
Fix arc	Through 2 points & radius	Radius
Float str	Centre & radius	Point X
Float arc	Centre & through point	Y
Free straight	Through 2 pts and bearing	Bearing at point
Free arc	Through pt, radius & brg	Hand of arc (T)
Add straight	Through 2 pts on diameter	
Add arc	Through 3 tangents	
Edit alignment	Copy alignment element	
Specials		
Clearance checking		
Amend design parameters		
End this alignment		

## Fix arc: two diameter points

IGIADS.DAT, IAD034, IAD002, IAD030

Element alignment	Define fix arc	Fix arc: 2 pts on diameter
Fix straight	Through 3 points	Alignment element name
Fix arc	Through 2 points & radius	Point 1 X
Float str	Centre & radius	Y
Float arc	Centre & through point	Point 2 X
Free straight	Through 2 pts and bearing	Y
Free arc	Through pt, radius & brg	Hand of Arc (T)
Add straight	Through 2 pts on diameter	
Add arc	Through 3 tangents	
Edit alignment	Copy alignment element	
Specials		
Clearance checking		
Amend design parameters		
End this alignment		

## Copy element

IGIADS.DAT, IAD034, IAD002, IAD057

Element alignment	Define fix arc	Copy element
Fix straight	Through 3 points	Originating element
Fix arc	Through 2 points & radius	Offset
Float str	Centre & radius	(T)
Float arc	Centre & through point	Direction (T)
Free straight	Through 2 pts and bearing	
Free arc	Through pt, radius & brg	
Add straight	Through 2 pts on diameter	
Add arc	Copy alignment element	
Edit alignment		
Specials		
Clearance checking		
Amend design parameters		
End this alignment		

**Copy element:** Is a method of specifying a fixed straight or arc. You use Copy Element to replicate or re-use an element that is already part of this or an earlier alignment. It is particularly useful for offset alignments. Having selected the element you wish to copy you type the offset by which you

want to displace the element (for an exact copy the offset will be zero). You may toggle the offset between left and right as defined by the direction of the original element. You may also toggle the direction of the copied element between original and reversed.

The fixity of the original element does not matter in computing the copied element.

## Define float straight

### Float straight: through point

IGIADS.DAT, IAD034, IAD003, IAD018

Element alignment	Define float straight	Float str: through point
Fix straight	Through a point	Alignment element name
Fix arc	With given bearing	Point X
Float str		Y
Float arc		Connecting element to (T)
Free straight		Connecting element
Free arc		Transition length
Add straight		
Add arc		
Edit alignment		
Specials		
Clearance checking		
Amend design parameters		
End this alignment		

## Float straight: given bearing

IGIADS.DAT, IAD034, IAD003, IAD019

Element alignment	Define float straight	Float str: given bearing
Fix straight	Through a point	Alignment element name
Fix arc	<b>With given bearing</b>	Bearing
Float str		Connecting element to (T)
Float arc		Connecting element
Free straight		Transition length
Free arc		
Add straight		
Add arc		
Edit alignment		
Specials		
Clearance checking		
Amend design parameters		
End this alignment		

## Define float arc

## Float arc: point and radius

IGIADS.DAT, IAD034, IAD004, IAD023

Element alignment	Define float arc	Float arc: point & radius
Fix straight	Through pt & given radius	Alignment element name
Fix arc	Through point and bearing	Point X
Float str	Through 2 points	Y
Float arc		Radius
Free straight		Hand of arc (T)
Free arc		Connecting element to (T)
Add straight		Connecting element
Add arc		Transition length
Edit alignment		
Specials		
Clearance checking		
Amend design parameters		
End this alignment		

## Float arc: point and bearing

IGIADS.DAT, IAD034, IAD004, IAD021

Element alignment	Define float arc	Float arc: point & bearing
Fix straight	Through pt & given radius	Alignment element name
Fix arc	Through point and bearing	Point X
Float str	Through 2 points	Y
Float arc		Bearing
Free straight		Hand of arc (T)
Free arc		Connecting element to (T)
Add straight		Connecting element
Add arc		Transition length
Edit alignment		
Specials		
Clearance checking		
Amend design parameters		
End this alignment		

## Float arc: 2 points

IGIADS.DAT, IAD034, IAD004, IAD020

Element alignment	Define float arc	Float arc: 2 points
Fix straight	Through pt & given radius	Element name
Fix arc	Through point and bearing	Intermed pt X
Float str	Through 2 points	Y
Float arc		End point X
Free straight		Y
Free arc		Seed radius
Add straight		Hand of arc (T)
Add arc		Connecting element to (T)
Edit alignment		Connecting element
Specials		Transition length
Clearance checking		
Amend design parameters		
End this alignment		

This facility enables you to define a float arc by constraining the arc to pass through 2 points. There are no restrictions on the type of element to which the float arc may be connected nor on the transition curve type which may be involved.

The calculation is iterative and as an aid to convergence a seed radius is required. This is your initial estimate of the radius which will make the curve

pass through the points given. It need not be very accurate - a guess by eye is usually sufficient. The iterative procedure is to float the arc through the end point adjusting the radius until it passes within 0.001 of a model unit of the intermediate point.

If the calculation fails it may be for one of two main reasons :-

1. The seed radius is not sufficiently accurate - if this is the case then the radius at the completion of the previous set of iterations will be given which will often be useful as the seed radius for a second set of iterations via MODIFY.
2. The geometry is not feasible. Either the points chosen are unrealistic or the hand of the curve is wrong. In these cases the iterations can behave unpredictably and cannot reach a solution.

As with all iterative calculations care should be taken to give feasible data otherwise wasted computer effort can result.

## Define free straight

IGIADS.DAT, IAD034, IAD005

Element alignment	Define free straight
Fix straight	Alignment element name
Fix arc	Preceding element
Float str	Transition length
Float arc	Following element
Free straight	Transition length
Free arc	
Add straight	
Add arc	
Edit alignment	
Specials	
Clearance checking	
Amend design parameters	
End this alignment	

## Define free arc

### Free arc: given radius

IGIADS.DAT, IAD034, IAD006, IAD031

Element alignment	Define free arc	Free arc: given radius
Fix straight	Given radius	Alignment element name
Fix arc	Through a point	Radius
Float str		Hand of arc (T)
Float arc		Preceding element
Free straight		Transition length
Free arc		Following element
Add straight		Transition length
Add arc		Solution (T)
Edit alignment		
Specials		
Clearance checking		
Amend design parameters		
End this alignment		

### Free arc: through point

IGIADS.DAT, IAD034, IAD006, IAD032

Element alignment	Define free arc	Free arc: Through point
Fix straight	Given radius	Alignment element name
Fix arc	Through a point	Point X
Float str		Y
Float arc		Seed radius
Free straight		Hand of arc (T)
Free arc		Preceding element
Add straight		Transition length
Add arc		Following element
Edit alignment		Transition length
Specials		Solution (T)
Clearance checking		
Amend design parameters		
End this alignment		

This facility enables you to define a free arc by constraining the arc to pass through a point. There are no restrictions on the type of elements to which



the free arc may be connected nor on the transition curves which may be involved.

The calculation is iterative and as an aid to convergence a seed radius is required. This is your initial estimate of the radius which will make the curve pass through the point given. It need not be very accurate - a guess by eye is usually sufficient. The iterative procedure is to repeatedly place the arc adjusting the radius until it passes within 0.001 of a model unit of the required point.

If the calculation fails it may be for one of 2 main reasons :-

1. The seed radius is not sufficiently accurate - if this is the case then the radius at the completion of the previous set of iterations will be given which will often be useful as the seed radius for a second set of iterations via MODIFY.
2. The geometry is not feasible. Either the point chosen is unrealistic or the hand of the curve is wrong. In these cases the iterations can behave unpredictably and cannot reach a solution.

As with all iterative calculations care should be taken to give feasible data otherwise wasted computer effort can result.

## Add straight

An added straight is defined by its length and is appended to an arc in an alignment. The straight can either be appended directly or following an inserted transition.

In addition, you can truncate or extend the arc to a fixed point before the straight is added. The point selected need not lie on the alignment but the alignment will be extended or truncated until a normal from the alignment passes through the point.

The bearing of the straight is equal to that at the end point of the arc or the transition to which the straight is added.

IGIADS.DAT, IAD034, IAD145

Element alignment	Add straight
Fix straight	Alignment element name
Fix arc	Connecting element
Float str	Connecting element to (T)
Float arc	Length
Free straight	Start pt X/Y
Free arc	Transition length
Add straight	
Add arc	
Edit alignment	
Specials	
Clearance checking	
Amend design parameters	
End this alignment	

**Alignment element name** is the name of the straight to be added.

**Connecting element** is the arc to which the straight is to be added.

**Connecting element to** is a toggle indicating whether the existing arc is to precede or follow the straight.

**Length** is the length of the straight and does not include the length of any transition being inserted.

**Start pt** is the point to which the existing arc is extended or truncated. By default, the end point of the arc is not changed.

**Transition length** is the length of the inserted transition. This length also determines the bearing of the added straight. No transition is created if the length is specified as zero.

◇ *It is not possible to add a straight to a straight.*

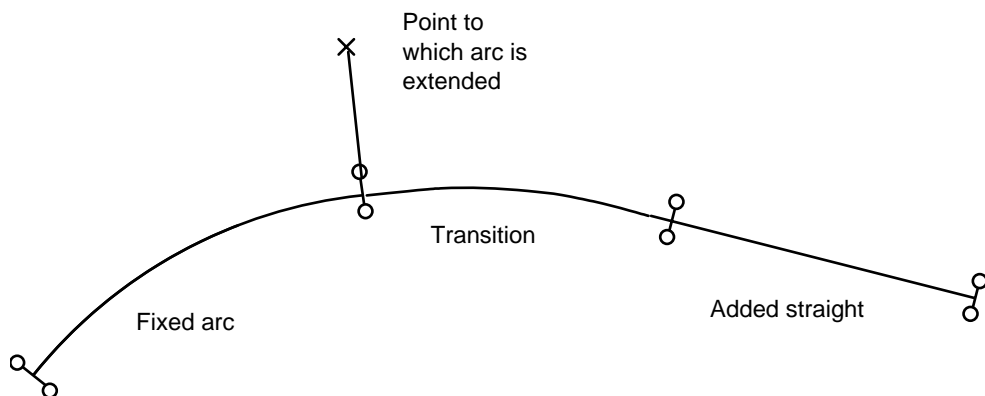


Figure 6 - 5 Add straight with transition

## Add arc

An added arc is defined by its length, radius and hand and is appended to a straight or an arc in an alignment. The arc can either be appended directly or following an inserted transition.

In addition, you can truncate or extend the element to a fixed point before the arc is added. The point selected need not lie on the alignment but the alignment will be extended or truncated until a normal from the alignment passes through the point.

The bearing at the start of the arc is equal to that at the end point of the element or transition to which the arc is added.

IGIADS.DAT, IAD034, IAD146

Element alignment	Add arc
Fix straight	Alignment element name
Fix arc	Connecting element
Float str	Connecting element to (T)
Float arc	Radius
Free straight	Hand of arc (T)
Free arc	Arc length
Add straight	Chord length
Add arc	Subtended angle
Edit alignment	Start pt X/Y
Specials	Transition length
Clearance checking	
Amend design parameters	
End this alignment	

**Alignment element name** is the name of the arc to be added.

**Connecting element** is the element to which the arc is added.

**Connecting element to** is a toggle indicating whether the existing element is to precede or follow the arc.

You have three choices of how to define the length of the added arc. These are the length along the arc itself, the length of chord required or the angle subtended at the centre of the arc. The latter is particularly useful for adding quadrants and semicircles. You select the method you require, enter the value and ALIGNMENT will add the arc.

**Start pt** is the point to which the existing element is extended or truncated. By default, the end point of the element is not changed.

**Transition length** is the length of the inserted transition. This length also determines the bearing of the added arc. No transition is created if the length is specified as zero.

◇ *Any type of transition may be used.*

- ◇ *It is not possible to add an arc to an arc of identical radius and of the same hand. Also the add element is stored as a floating element in the data and later options (particularly Respecify Link) will use this definition as the basis of its calculations.*
- ◇ *If an arc is added to an existing arc, it must be added without a transition.*

## Special geometry

IGIADS.DAT, IAD034, IAD082

Element alignment	Special geometry
Fix straight	Single element alignment
Fix arc	Fix to fix
Float str	Create three centre curve
Float arc	
Free straight	
Free arc	
Add straight	
Add arc	
Edit alignment	
Specials	
Clearance checking	
Amend design parameters	
End this alignment	

Apart from the methods described above for defining the geometry of an alignment there are some special cases which deserve individual description, as follows:

**Single element alignment:** When only a single element constitutes a complete alignment you design the alignment using Single element alignment. You will be prompted to select the element to include in your alignment and this will then be drawn as the alignment.

## Fix to fix

IGIADS.DAT, IAD082, IAD081

Special geometry	Fix to fix
Single element alignment	Preceding fixed element
Fix to fix	Following fixed element
Create three centre curve	Common radius
	Transition constant ratio

With this menu you can connect fixed elements with special arrangements of transitions:

- S curves
- C curves
- straight-to-straight through common radius.

### Arcs of opposite hand - S curves

When fixed arcs of opposite hand are joined by transitions with no intermediate straight, the geometric arrangement is known as an S curve.

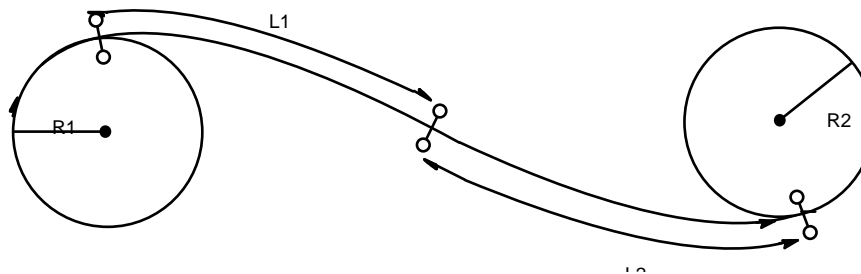


Figure 6 - 6 S curves

$$R1 = R2 \text{ and } L1 = L2$$

Often the transition constant for each of the transitions in the pair is the same. This means that for two arcs of equal radius but opposite hand, the transitions will be equal in length.

If the two arcs have different radii then the lengths will be in inverse proportion to the radii.

To produce an S curve, you identify only the Preceding fixed element and the Following fixed element. The Common radius is not relevant. The transition constant ratio is set to 1.0 by default.

The *Transition constant ratio* is the ratio of the RL values for adjacent transition curves. If the *Transition constant ratio* is left at the default of 1.0 then the transitions will be the same length if the arcs are of equal radii. If the transition constant ratio is set to 2.0 the first transition will be twice as long as the second. A transition constant ratio of 0.5 would make the second transition twice as long as the first.

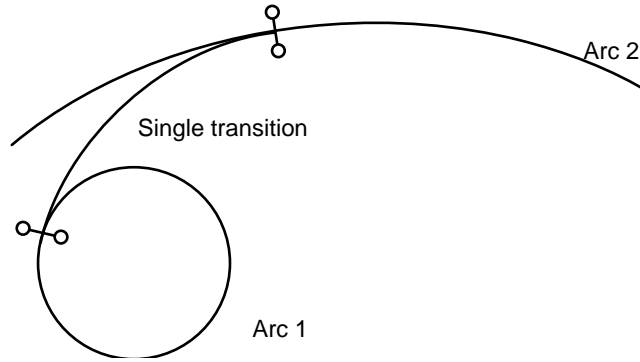
When the arcs have unequal radii the Transition constant ratio could be used to equalise the transition lengths by making the ratio the inverse proportion of the radii.

◇ *Users in continental Europe should note that the Transition constant ratio is the ratio of  $A^2$  (because  $A=\sqrt{RL}$ ).*

#### Arcs of the same hand - C (compound) curves

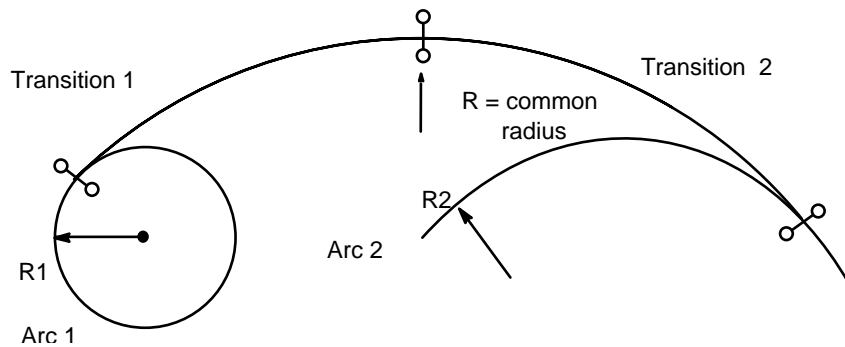
There are two methods for inserting transitions between fixed arcs of the same hand.

For two fixed arcs with different radii there may be a single part transition which can connect them. ALIGNMENT will insert this transition if you supply Preceding fixed element and Following fixed element, but leave the other menu boxes blank.



**Figure 6 - 7 C curve with a single transition**

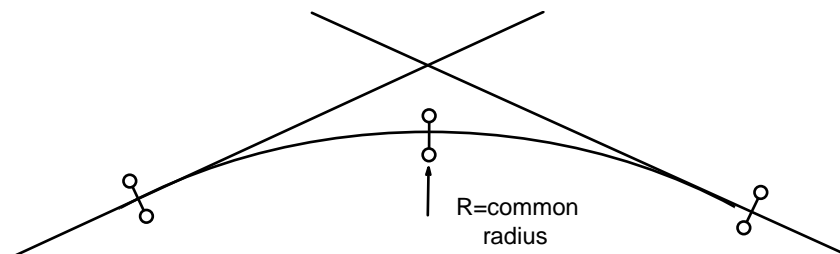
Alternatively you can insert two partial transitions which are tangential at a specified common radius. This Common radius must be greater than both the fixed arc radii:



**Figure 6 - 8 C curve with two transitions**

### Straight to straight

You can insert two transitions between fixed straights. You must define the Common radius, ie the radius at which the transitions abut.



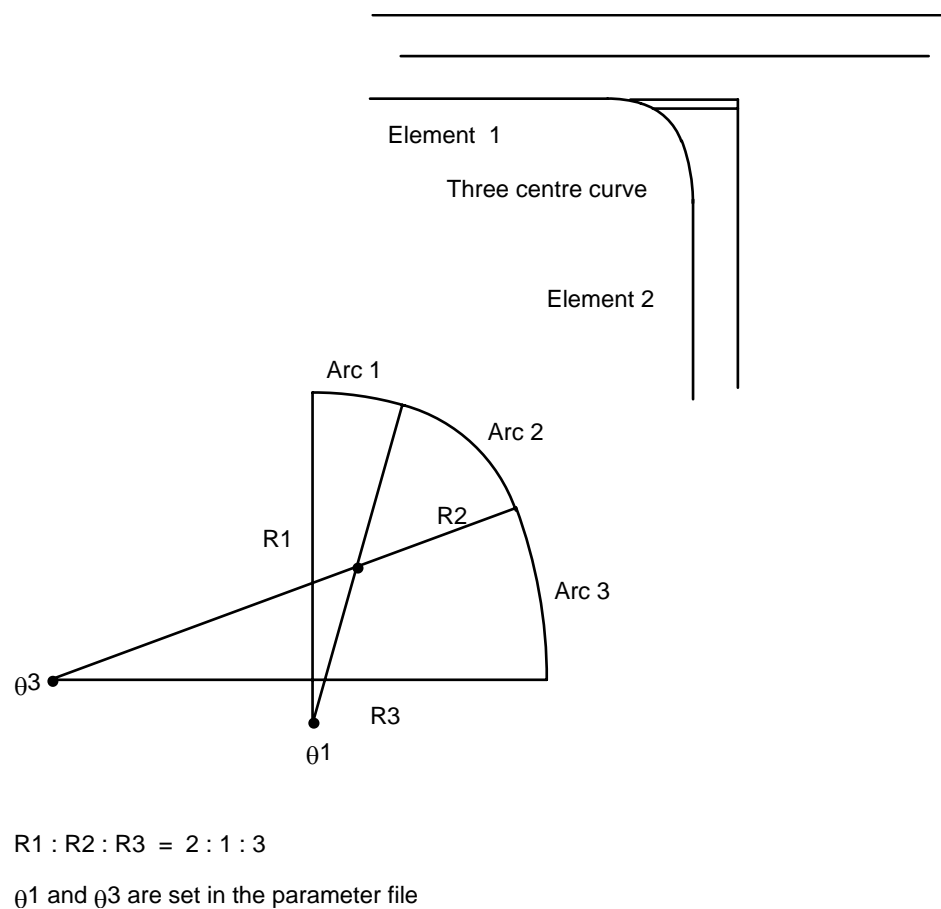
**Figure 6 - 9 Straight to straight**

## Create three centre curve

Generate a three centre curve and insert it between two fixed circular or straight elements.

Three centre curves are commonly used in junction design. The radius of the middle arc of the curve is defined by the user, and from this a ratio is used to calculate the radii of the outer arcs. The length of each outer arc is determined by a stored subtended angle, or is specified by the user.

The default ratio and subtended angles of the outer arcs are stored in the parameter file.



**Figure 6 - 10 Three centre curve**



IGIADS.DAT, IAD082, IAD015

Special geometry	Create three centre curve
Single element alignment	Arc 2 name
Fix to fix	Arc 1 name Arc 3 name
Create three centre curve	Preceding element
	Following element
	Radius of arc 2
	Hand of arc 2 (T)
	Approx X
	Approx Y
	Arc 1 radius
	Arc 3 radius
	Arc 1 angle
	Arc 3 angle
	Arc 1 length
	Arc 3 length

**Arc 2 name** is the element name of the middle arc in the three centre curve.

**Arc 1 name** is the element name of the arc joining the preceding element with arc 2.

**Arc 3 name** is the element name of the arc joining arc 2 with the following element.

**Preceding element** is the element to which arc 1 of the three centre curve is to be joined.

**Following element** is the element to which arc 3 of the three centre curve is to be joined.

**Radius of arc 2** determines the radii of arc 1 and arc 3 by use of a ratio stored in the parameter file. The angles subtended by arc 1 and arc 3 are also stored in the parameter file. When the radius of arc 2 is specified, the remaining data for arcs 1 and 3 is automatically displayed in the menu.

**Hand of arc 2** is a toggle which determines whether the three centre curve is left hand or right hand.

**Approx X** and **Approx Y** are used to indicate the approximate coordinates of the centre of arc 2.

Arcs 1 and 3 **radius**, **angle** and **length** are all calculated from the radius of arc 2 but may be overridden if required.

If you override the angle, the length is also updated to reflect the new value, and vice versa.

### Producing the curve

To produce a three centre curve in alignment, the following stages are required:

⇒ Select 'Create three centre curve' from the 'Special geometry' menu.

The 'Create three centre curve' menu is displayed and 'Preceding element' is automatically highlighted.

⇒ Select the element to precede the three centre curve.

'Following element' is automatically highlighted.

⇒ Select the element to follow the three centre curve.

The 'Radius of arc 2' field is automatically highlighted. The radius you type here also determines the radii of arc 1 and arc 3.

⇒ Type the radius of arc 2.

'Approx X and Y' is automatically highlighted. These coordinates indicate the approximate centre of arc 2 so that the three centre curve is drawn in the correct location relative to the preceding and following elements.

⇒ Select or type a coordinate position which is near to the centre of arc 2.

⇒ Select Proceed and the menu is displayed with details of arcs 1, 2 and 3.

Check the details in the menu and modify them if required.

⇒ Select Proceed to locate arc 2 and display the 'Alignment review' menu.  
From this menu:

Select 'Accept' to accept arc 2 and automatically insert arc 1 between the preceding element and arc 2.

Select 'Accept' to accept arc 1 and automatically insert arc 3 between arc 2 and the following element.

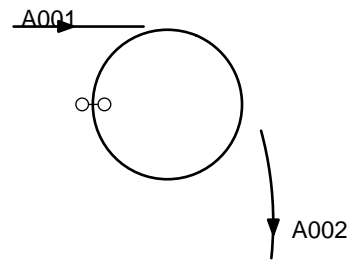
Select 'Accept' to accept arc 3.

The three centre curve is completed and the 'Element alignment' menu is displayed.

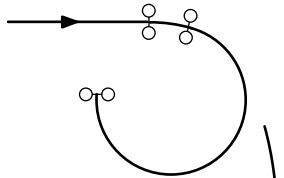
It is possible that the solution you require when creating arc 1 or arc 3 will not be the first solution found. If this is the case:

⇒ Select 'Modify' to go to the 'Free arc:given radius' menu and toggle the solution field.

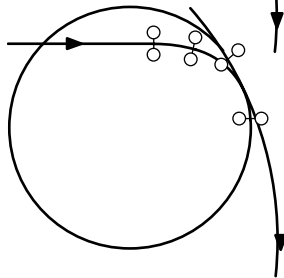
⇒ Select Proceed to redraw the alignment and return to the 'Alignment review' menu from where you may continue as before.



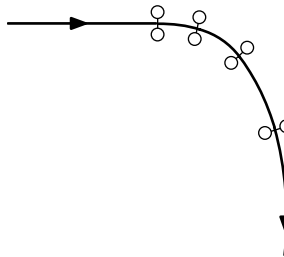
Accept arc 2



Accept arc 1



Modify arc 3  
(second solution required)

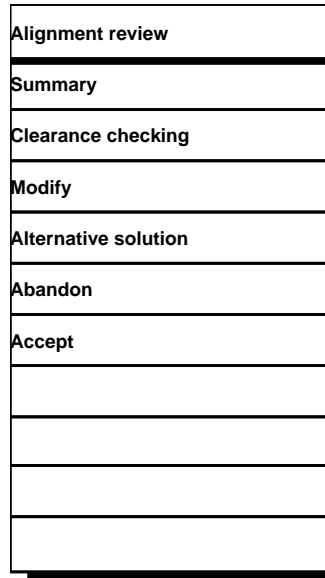


Accept arc 3

Figure 6 - 11 Create three centre curve

## Alignment review

IGIADS.DAT, IAD065



As each free or floating element is resolved it is superimposed on the drawing, and the Alignment review menu above appears in the SMA.

**Summary:** Gives a menu summary of the alignment which has been analysed. The alignment will be highlighted on the screen. This information helps you decide whether your data needs amending.

**Clearance checking:** Displays sub-menu Clearance checking. This gives you the opportunity to evaluate critical points in relation to your element by giving the distance from the point to the nearest point on the alignment.

**Modify:** If you wish to modify your alignment, select 'Modify'. You will be presented with a menu defining data for the free or floating element in the analysis, and you can change whichever data item(s) you require.

**Abandon:** This will remove reference to the element definition for the free or floating element and will return you to the Element alignment menu.

**Accept:** If you are happy with the element as defined it will become a permanent part of the alignment. You can then go on to define the next element.

- ◇ *Free arcs can give rise to 'alternative solutions'. If an alternative solution is possible the Alternative solution item will appear in the Alignment review menu. Select this item to calculate the alternative solution, and select it again to return to the original.*
- ◇ *When the analysis of an alignment results in diagnostics an appropriate menu is displayed which tells you how many diagnostic messages have*

been produced, in addition to the usual information. You can display each message in turn in the diagnostic area at the top of the screen by selecting Display next message in the menu, as many times as you like. If you select it more times than there are diagnostics produced, you will be returned to the first message, and so on round the cycle.

## Clearance checking

IGIADS.DAT, IAD034, IAD008

Element alignment	Clearance checking
Fix straight	Check pt X
Fix arc	Y
Float str	Distance to alignment
Float arc	Align pt X
Free straight	Y
Free arc	
Add straight	
Add arc	
Edit alignment	
Specials	
Clearance checking	
Amend design parameters	
End this alignment	

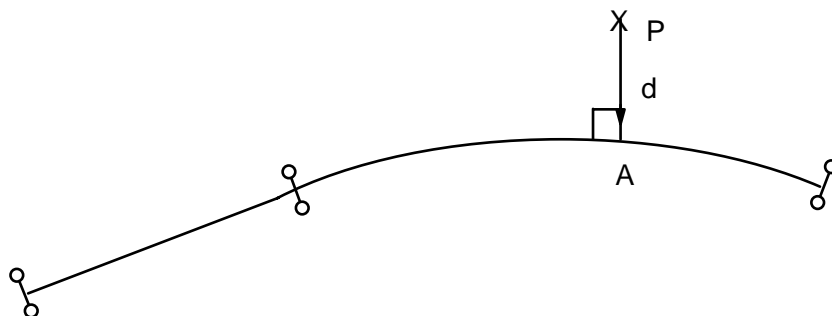


Figure 6 - 12 Example - clearance

In the diagram the closest position to point P on the alignment is point A, along the normal. Clearance reports the coordinates of A together with the distance d between P and A.

## Edit alignment

IGIADS.DAT, IAD034, IAD174

Element alignment	Edit alignment
Fix straight	Respecify element
Fix arc	Delete element
Float str	Reverse element
Float arc	Lengthen alignment
Free straight	Truncate alignment
Free arc	Translate alignment
Add straight	Rotate alignment
Add arc	Reverse alignment
Edit alignment	Split alignment
Specials	Respecify link
Clearance checking	Delete links
Amend design parameters	Swap link
End this alignment	

When an alignment is complete or partially complete you can edit it to revise the geometry.

You can edit:

- elements prior to analysis
- alignments or part-alignments
- individual links within alignments after analysis.

All edits involving alignments, part alignments or links have a 'safety catch' in that the results of your edit will be displayed, after which you can either accept them, making them permanent, or return to the position prior to the edit.

**Respecify element:** Respecifies an element which has not yet been included within an alignment. This process will redisplay the original data for the element and any data items can be amended.

**Delete element:** Deletes an element which has not been included within an alignment.

**Reverse element:** Reverses an element which has not been included within an alignment.

## Lengthen alignment

Extends an alignment.

IGIADS.DAT, IAD034, IAD174, IAD070

Element alignment	Edit alignment	Lengthen alignment
Fix straight	Respecify element	From X
Fix arc	Delete element	Y
Float str	Reverse element	Distance to lengthen by
Float arc	Lengthen alignment	To X
Free straight	Truncate alignment	Y
Free arc	Translate alignment	
Add straight	Rotate alignment	
Add arc	Reverse alignment	
Edit alignment	Split alignment	
Specials	Respecify link	
Clearance checking	Delete links	
Amend design parameters	Swap link	
End this alignment		

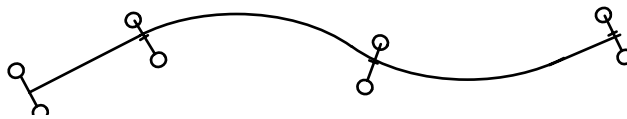


Figure 6 - 13 Original alignment

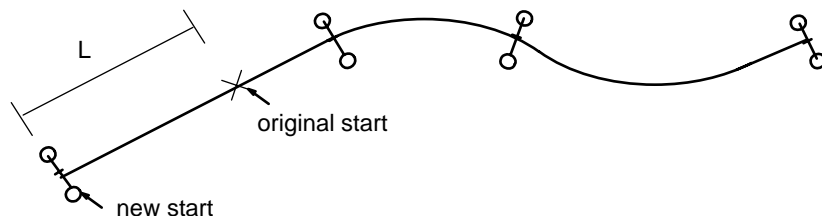


Figure 6 - 14 Lengthen by given length

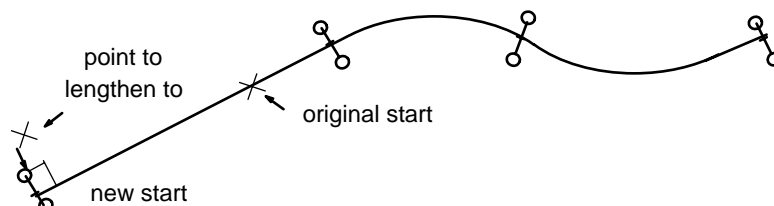


Figure 6 - 15 Lengthen to a point

**From X and Y:** Select the tangent point at the start or end, depending on which needs to be extended.

You can extend:

- **by distance:** using the standard data selection methods
- **to a point:** using the point selection methods. The point selected need not lie on the alignment but the alignment will be extended until a normal from the alignment passes through the point.

## Truncate alignment

This is the converse of lengthen alignment and similar principles apply. In addition, if the amount by which this alignment is truncated is greater than one or more links, those links will be deleted from the alignment.

IGIADS.DAT, IAD034, IAD174, IAD071

Element alignment	Edit alignment	Truncate alignment
Fix straight	Respecify element	From X
Fix arc	Delete element	Y
Float str	Reverse element	Distance to truncate by
Float arc	Lengthen alignment	To X
Free straight	Truncate alignment	Y
Free arc	Translate alignment	
Add straight	Rotate alignment	
Add arc	Reverse alignment	
Edit alignment	Split alignment	
Specifcals	Respecify link	
Clearance checking	Delete links	
Amend design parameters	Swap link	
End this alignment		

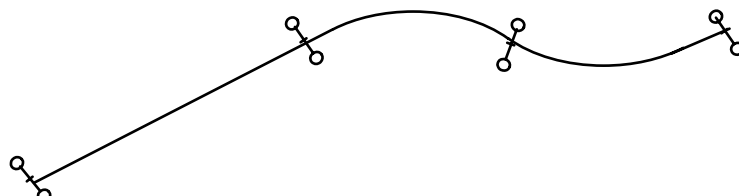


Figure 6 - 16 Original alignment



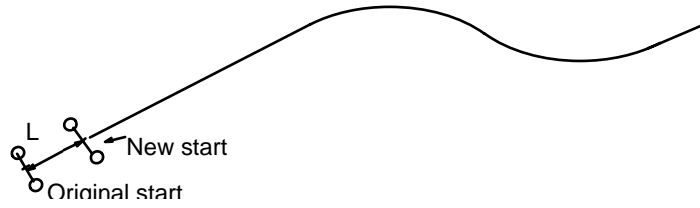


Figure 6 - 17 Truncate by distance

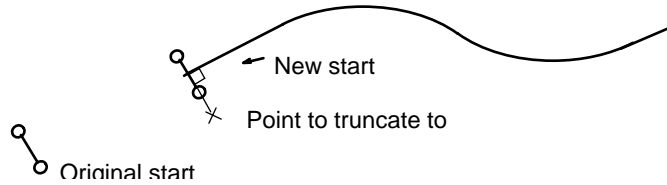


Figure 6 - 18 Truncate to a point

## Translate alignment

IGIADS.DAT, IAD034, IAD174, IAD072

Element alignment	Edit alignment	Translate alignment
Fix straight	Respecify element	Ref point X
Fix arc	Delete element	Y
Float str	Reverse element	Move to X
Float arc	Lengthen alignment	Y
Free straight	Truncate alignment	Part alignment
Free arc	Translate alignment	
Add straight	Rotate alignment	
Add arc	Reverse alignment	
Edit alignment	Split alignment	
Specials	Respecify link	
Clearance checking	Delete links	
Amend design parameters	Swap link	
End this alignment		

**Translate alignment:** moves the alignment. First you identify the reference point and then its new point. With judicious use of point selection methods and data amendment methods this option can be very versatile.

**Part alignment:** allows you to select a part of an alignment, which will be translated while the other part(s) remain in position.

If you select Proceed without selecting Part alignment then the whole of the alignment will be moved.

## Rotate alignment

IGIADS.DAT, IAD034, IAD174, IAD073

Element alignment	Edit alignment	Rotate alignment
Fix straight	Respecify element	Ref point X
Fix arc	Delete element	Y
Float str	Reverse element	Rotate by
Float arc	Lengthen alignment	Part alignment
Free straight	Truncate alignment	
Free arc	Translate alignment	
Add straight	Rotate alignment	
Add arc	Reverse alignment	
Edit alignment	Split alignment	
Specials	Respecify link	
Clearance checking	Delete links	
Amend design parameters	Swap link	
End this alignment		

**Rotate by:** function is similar to Translate. Use any of the point selection methods to identify the centre of rotation, and then give the rotation required.

**Part alignment:** allows you to rotate part of the alignment while the other part(s) remain in their original position.

If you select Proceed without selecting **Part alignment** then the whole of the alignment will be rotated. To select a subset of elements request Part alignment and identify the subset to be rotated.

## Reverse alignment

IGIADS.DAT, IAD034, IAD174, IAD074

Element alignment	Edit alignment	Reverse alignment
Fix straight	Respecify element	Complete alignment
Fix arc	Delete element	Part alignment
Float str	Reverse element	
Float arc	Lengthen alignment	
Free straight	Truncate alignment	
Free arc	Translate alignment	
Add straight	Rotate alignment	
Add arc	Reverse alignment	
Edit alignment	Split alignment	
Specials	Respecify link	
Clearance checking	Delete links	
Amend design parameters	Swap link	
End this alignment		

Having created your alignment as a series of elements, you may wish to reverse its direction. There are three possible arrangements for your data:

- All the elements are connected into one continuous alignment. Select Proceed, and Reverse alignment will automatically reverse it all.
- All the elements are not connected continuously but you want them all reversed anyway. Select Proceed.
- The elements are not connected continuously and only one subset needs to be reversed. Select **Part Alignment** and the subset of elements to be reversed, then select Proceed.

## Split alignment

IGIADS.DAT, IAD034, IAD174, IAD075

Element alignment	Edit alignment	Split alignment
Fix straight	Respecify element	Split point X
Fix arc	Delete element	Y
Float str	Reverse element	
Float arc	Lengthen alignment	
Free straight	Truncate alignment	
Free arc	Translate alignment	
Add straight	Rotate alignment	
Add arc	Reverse alignment	
Edit alignment	Split alignment	
Specials	Respecify link	
Clearance checking	Delete links	
Amend design parameters	Swap link	
End this alignment		

When you first add elements to your alignment they need not be connected, in which case your alignment will consist of a series of part-alignments.

1  
2  
-

**Figure 6 - 19 Example of split alignment**

In Figure 6 - 19 the alignment consists of elements 1, 2, 3, 5, 6 but with no connectivity between (1, 2, 3) and (5, 6).

Eventually you may connect them all into one continuous alignment. The reverse process is also possible. For example, you may have a continuous alignment but wish to split it and then add further elements. When splitting

an alignment a new start and end point are added at the split point. The chainage at the added start point is made zero, and an additional element is added here to correspond with the splitting of the previous element which had spanned the split point.

## Respecify link

IGIADS.DAT, IAD034, IAD174, IAD175

Element alignment	Edit alignment	Respecify link
Fix straight	Respecify element	Link
Fix arc	Delete element	
Float str	Reverse element	
Float arc	Lengthen alignment	
Free straight	Truncate alignment	
Free arc	Translate alignment	
Add straight	Rotate alignment	
Add arc	Reverse alignment	
Edit alignment	Split alignment	
Specials	Respecify link	
Clearance checking	Delete links	
Amend design parameters	Swap link	
End this alignment		

**Respecify link:** is another facility for localised editing, most commonly used to change the radius of an arc in an alignment.

To use it, first you nominate a link to respecify, and a menu is displayed for that link as a free element. If it's an arc, you can then either respecify its radius or change its transition specification, for a straight you can only change its transition specification.

The facility works by automatically deleting the link being respecified and replacing it with a new free element, regardless of the fixity of the original element. The adjacent elements are considered fixed in their original analysed position, with the new free element between them. This is regardless of the fixity of these adjacent elements in their original specification.

The analysis is subject to the ACCEPT/MODIFY/ABANDON prompt, and if you select MODIFY the menu displayed will be for the respecified element.

Respecify link is best used for the purpose for which it was designed (localised edits within the alignment) but it can also be used to make major changes to alignments.

## Delete link

IGIADS.DAT, IAD034, IAD174, IAD077

Element alignment	Edit alignment	Delete link
Fix straight	Respecify element	Single link
Fix arc	Delete element	Delete from X
Float str	Reverse element	Y
Float arc	Lengthen alignment	Delete to X
Free straight	Truncate alignment	Y
Free arc	Translate alignment	
Add straight	Rotate alignment	
Add arc	Reverse alignment	
Edit alignment	Split alignment	
Specials	Respecify link	
Clearance checking	Delete links	
Amend design parameters	Swap link	
End this alignment		

You can delete single elements from an alignment but you may also want to delete a series of elements, including their associated transitions. Delete links will remove the lines between their tangent points. Some of the original elements that were included in the linked alignment will still remain as free-standing elements on the screen.

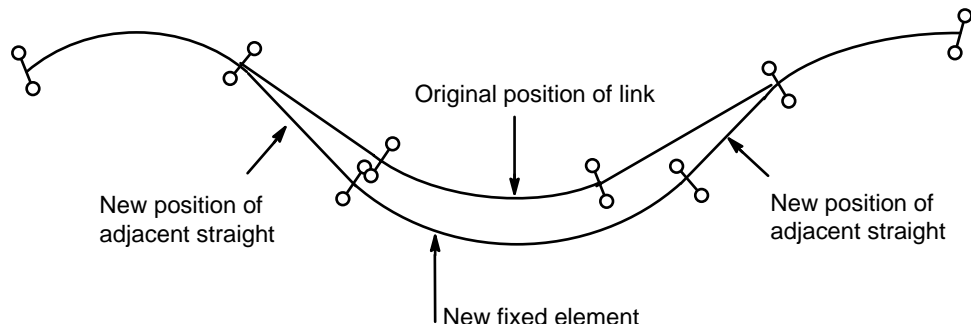
## Swop link

IGIADS.DAT, IAD034, IAD175, IAD089

Element alignment	Edit alignment	Swop link
Fix straight	Respecify element	Link to be swopped
Fix arc	Delete element	Replacement element
Float str	Reverse element	
Float arc	Lengthen alignment	
Free straight	Truncate alignment	
Free arc	Translate alignment	
Add straight	Rotate alignment	
Add arc	Reverse alignment	
Edit alignment	Split alignment	
Specials	Respecify link	
Clearance checking	Delete links	
Amend design parameters	Swap link	
End this alignment		

**Swop link:** is for performing localised edits within the alignment. You use it to edit an alignment locally without having to delete those parts of it that need to be changed.

For example, you can swop an analysed link for an unanalysed fixed element, with the links adjacent to the original link moving to accommodate the position of the new element, as shown in Figure 6 - 20.



**Figure 6 - 20 Example - swop link**

The crux of Swop link is that the new element is a fixed element regardless of the original fixity of the element it replaces. The adjacent elements, in order to be included in the revised alignment, then become free elements and again this is regardless of their original fixity. (At the ends of alignments the mechanism is slightly different but the principles still hold).

Thus the program has to perform two analyses, one for each of the free elements either side of the new element. It undertakes these in order of increasing chainage. Each is subject to a MODIFY/ACCEPT/ABANDON prompt: if you select MODIFY the displayed menu will be the one for the adjacent element in question defined as the free element.

So for most Swop links you will have to ACCEPT the calculation at three stages:

- after the analysis preceding the new element
- after the analysis following the new element
- after the overall edit.

To help in this, the system displays the original alignment as well as the revised one.

Swop link is best used for the purpose for which it was designed (localised edits within an alignment) but it can also be used to make major edits to alignments.

## Display parameters

IAD295

Display parameters	
Elements	(T)
	(T)
Align strs	(T)
	(T)
Align arcs	(T)
	(T)
Align trns	(T)
	(T)
Background	(T)
	(T)
Direction	(T)
Tangent pts	(T)
Auto annotate	(T)
Reset params to default	

For each alignment you can choose how each component is displayed while you are working with it. You can choose the colour and line style of the following components:

**Elements:** This is the element as it is defined. For example a circle based on a centre and radius would be displayed as the whole circle; a straight between two points would be displayed as the two end points and the line between them.

**Alignment straights:** The portion of the straight element(s) that actually lies on the alignment can be displayed in its own colour and linestyle.

**Alignment arcs:** The portion of the circular arc element(s) that actually lies on the alignment can be displayed in its own colour and linestyle.

**Alignment transitions:** The portion of transition(s) that actually lies on the alignment can be displayed in its own colour and linestyle.

**Background colour:** This is the colour in which the alignment is displayed when it is not the current alignment. This facility is particularly useful in preparing preliminary designs, where you can have a red route, a green, and so on.

**Background style:** This is the style in which the alignment is displayed when it is not the current alignment.

**Direction:** This symbol, which illustrates the direction of elements and shows whether a curve is left handed or right handed, is shown by default. You can make it invisible if necessary.

**Tangent points:** The symbol that illustrates tangent points is shown by default but may be made invisible if necessary.



All the GDS properties above are specified on a toggle basis, so you continue to toggle until you reach your choice.

**Auto annotate:** This is a toggle which determines whether fixed elements and alignment links are automatically annotated when they are created. The annotation is positioned along both sides of the element or link and gives information concerning the geometry of the element. For example, a fixed straight is annotated with its length and bearing as shown in Figure 6 - 21.

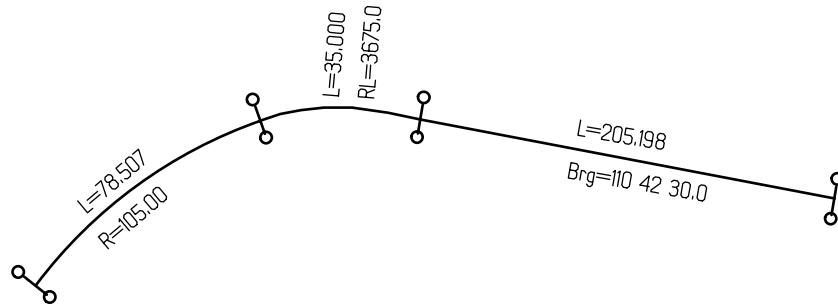


Figure 6 - 21 Alignment annotation

Each piece of annotation has a prefix of up to four characters in length which is defined in the message file. Refer to the System Manager's Reference for details of how to modify the message file.

At any time, if auto annotation is selected, the whole of the alignment is annotated.

**Reset params to default:** Resets all the display parameters to the default values held in the parameter file. See Chapter 2 for a description of the parameter file.

◇ *Colours chosen in horizontal alignment will automatically be carried forward to vertical design, where they may be overridden if required.*

If you wish to save your changes and return to the 'Horizontal design' menu, select Proceed.

If you wish to cancel your changes and return to the 'Horizontal design' menu, select Quit.

The values you have chosen take effect when you proceed from the 'Horizontal design' menu. The current alignment is redrawn according to the new values.

## Design parameters

IAD296

Design parameters
Units (R)
Angular input (T)
Radius use (T)
Transition rules (T)
Transition formula (T)
Transition defined by (T)
Transition overridden by (T)
Transition default parameter
Vertical align (R)
Horizontal design (R)
Reset params to default

**Units** is for information only and displays the type of units in use (metric or imperial).

**Angular input/output:** There are five ways of supplying angular data and you may toggle through the alternatives until you reach your choice.

- DMS            Degrees minutes and seconds.
- DDD.DDD    Degrees and decimal degrees.
- Grad           Grads.
- Rads           Radians.
- Quad          Quadrant Bearings.

For examples of each format, refer to Chapter 2.

**Radius use:** This is a 3-way toggle which defines the way that certain menu boxes will interpret the entry of a radius. The menu boxes are all those that require entry of a radius, in horizontal design only.

The usual toggle is RADIUS, which is the default. In this position all radii are interpreted as radii.

The alternative toggles are DOC(A) and DOC(C) (DOC stands for 'degree of curvature'). Under these, all radii are interpreted as angles in the current angular input style.

Under DOC(A), the angle is that corresponding to a 100 model unit arc length.

Under DOC(C), the angle is that corresponding to a 100 model unit chord length.

These alternative toggles are offered mainly for countries that use these methods in conjunction with design tables as the standard technique for defining the radius of an arc.

**Transition rules** allow transition curves to be designed to a national standard. The rules selected control the settings of all the other transition fields in this menu.

- If 'None' is selected, no specific set of design rules are used, and any of the transition formula may be selected.
- French roads (F ROADS) use a decision table technique based on French design rules. If this method is selected, only clothoid transition formulae apply. On Proceed from this menu with this setting, the 'French transitions' menu will be displayed.
- Dutch railways (NL RAIL) use automatic clothoid length calculation. If this method is selected, only clothoid transition formulae apply. On Proceed from this menu with this setting, the 'Dutch transitions' menu will be displayed.

**Transition formula:** Leading or trailing transitions may be specified for each of the arcs. The curve of the transition is determined by the formula used to calculate it.

The type of transition curves used in alignment vary from country to country. However, they have a common purpose in that they ensure that both curvature and bearing are continuous throughout an alignment.

- 'Notrans' is used when no transition curves are to be used in the current alignment.
- Clothoid transitions are sections of a clothoid spiral which has a constant rate of change of curvature with respect to distance.
- Bloss curves are another type of transition curve which have their own special associated superelevation calculations.
- Cubic parabolae have a linear rate of change of both curvature and superelevation along the tangent to the transition.
- Biquadratic parabolae are used in some countries for high speed railway design and will generally give longer transitions than clothoids. They are mostly used for design speeds between 160 and 300 kph. A biquadratic parabola is always specified by its length along the tangent to the transition, rather than along the curve itself. Biquadratic parabolae also have their own special associated superelevation calculations.
- Sine curves are another type of curve used extensively for railway design.

**Transition defined by** is a toggle which may be set to any of the following if 'Transition rules' is set to 'None':

- Lengths (all transition formulae)
- Default RL (clothoid transitions only)
- 'A' value (clothoid transitions only)
- Speed (clothoid transitions only)

This field can also display the following if national transition rules are in use or if no transitions are to be included:

- Rules (formulae determined by transition rules)
- N/A (not applicable; no transitions in use)

When you have chosen the toggle required, transitions in the alignment you are designing will be calculated using the corresponding value displayed in the menu.

**Transition overridden by** is also a toggle which determines how an individual transition may be calculated if a different value from the one chosen previously is required. The override takes place when the transition is being defined.

For example, if you specify the following values:

Transition defined by: Default RL  
 Transition overridden by: Default RL  
 Transition default parameter: 10000

each transition will be calculated with an RL value of 10000 unless you type in a value. If you do type in a value, it will be taken as an RL value.

If, however, you specify the following values:

Transition defined by: Default RL  
 Transition overridden by: Lengths  
 Transition default parameter 10000

each transition will be calculated with an RL value of 10000 unless you type in a value. In this case, the value you type in will be taken as the length of the transition.

◇ *When the length of transition is specified it is measured from its origin, ie, where the radius of the transition is infinity.*

◇ *It is not possible to override 'Lengths' with any of the other values.*

**Transition default parameter** is the default RL, A value or speed to be used when defining transitions. This value is defined in the parameter file. If you select this field, you may type in a new value which becomes the default for the current alignment.

**Vertical alignment** is for information only and is only relevant for existing alignments. If the current horizontal alignment has an associated vertical alignment, it is set to YES; otherwise it is set to NO.

**Railway design** is for information only and indicates whether you are allowed to include switches in your alignment or not.

**Reset params to default** resets all the design parameters to the default values held in the parameter file, except for those which are dependent upon other values. See Chapter 2 for a description of the parameter file.

## French transitions

IGIADS.DAT, IAD099

French transitions
Design speed (T)
Number of lanes (T)
Road classification (T)

This menu is used to set up default values so that transition lengths can be calculated automatically according to French design criteria.

**Design speed:** Toggle through the supplied values to select the required default.

**Number of lanes:** Toggle through the supplied values to select the required default.

Road classification: Toggle through the supplied values to select the required default.

AR \_\_\_\_\_ Autoroute (motorway)

RP \_\_\_\_\_ Route principale (major road)

UR \_\_\_\_\_ Route urbaine (urban road)

For further details of French design rules, refer to Chapter 7, major option HALGN.

~~**Road classification:** Toggle through the supplied values AR (Autoroute), RN (Route Nationale), UR (Urban Route) to select the required default.~~

## Dutch transitions

IGIADS.DAT, IAD264

Dutch transitions
Design speed
Def deficiency factor
Default gradient type (T)
Min theoretical crossfall
Max theoretical crossfall
Max allowable crossfall

This menu is used to set up default values so that transition lengths can be calculated automatically according to Dutch design criteria.

**Design speed:** Specify the design speed for the alignment you are using.

**Default deficiency factor:** Type the required value. For a description of how the deficiency factor is used, see 'Clothoid length calculation' in the 'Railways' section of this chapter.

**Default gradient type:** Toggle through the supplied values. For a description of how the deficiency factor is used, see 'Clothoid length calculation' in the 'Railways' section of this chapter.

**Minimum theoretical crossfall:** Specify the minimum crossfall. The crossfall imposed on automatically calculated transitions does not fall below this value.

**Maximum theoretical crossfall:** Specify the maximum crossfall. The crossfall imposed on automatically calculated transitions does not exceed this value.

**Maximum allowable crossfall:** Specify the maximum crossfall you wish to allow once the deficiency factor has been taken into consideration.

Select Proceed to accept the design parameters.

# Horizontal IP method

## Introduction

The Intersection Point Method is offered as an alternative to Element method to accord with engineering practice in many countries. It is based on the alignment being constructed in the sequence STRAIGHT/ARC/ STRAIGHT/ARC with the possibility of including transitions. The sequence above can be modified to include arc to arc connections in some circumstances.

There are two modes of operation of IP method. "three IP" mode accepts data in a repetitive sequence IP-IP-Insert curve. "ALL IP" mode accepts data for all IPs and then you insert arcs in whichever sequence you wish by picking the IP opposite which the arc is to be placed.

These methodologies duplicate those available in the vertical IP method. It must be emphasised that the same mathematical procedures underlie the element method and the IP method. The IP method offers considerable data preparation convenience but there are situations when the element method would solve a part of an alignment more easily. It is therefore possible to switch between IP and element methods and vice versa by returning to the 'Amend parameters' menu and selecting the method of design.

- ◇ *Some of the menus which appear within Horizontal design (IP) are very similar to those which appear in Horizontal design (Element) and are not documented separately.*

## IP alignment

IGIADS.DAT, IAD036,

IP Alignment	
Start IP X	
Y	
Next IP X	
Y	
Absolute brg	
Length	
Relative brg	
Length	
Exist IP X	*
Y	
Construct IP	
Edit alignment	
Insert arc	
Clearance checking	
Amend parameters	
End this alignment	

IP Alignment is used to create straight elements. Arcs may then be inserted at the intersection points of these elements.

**Start IP** is used to specify the coordinates of the first point of a straight element.

**Next IP** is used to specify the coordinates of subsequent points on straight elements. Each time a point is specified, a straight element is drawn between this point and the previous point.

An **absolute bearing** and **length**, or a **relative bearing** and **length**, may be used to specify the position of subsequent points if required.

When an intersection point is formed, 'Arc in IP alignment' is automatically displayed so that you may insert an arc at the intersection point. See 'Arc in IP alignment' for further details.

**Exist IP** is used to specify the coordinates of an existing intersection point.

**Construct IP** is used to insert an intersection point between two separated part alignments, so that an arc may be inserted.

**Edit alignment** is at the head of a family of menus which allow you to edit an existing alignment.

**Insert arc** allows you to insert an arc at an intersection point.

**Clearance checking** is used to check the shortest distance between a specified point and an alignment.

**Amend parameters** returns you to the 'Horizontal design' menu. From 'Horizontal design', you may change the display or the design parameters, as well as the design method (within certain restrictions). Select Quit or Proceed to return to the 'Element alignment' menu.

**End this alignment** ends the current alignment and returns you to the 'Continue alignments' menu.



## Construct IP

IGIADS.DAT, IAD036, IAD038

IP Alignment	Construct IP
Start IP X Y	Preceding element
Next IP X Y	Following element
Absolute brg Length	
Relative brg Length	
Exist IP X Y	
Construct IP	
Edit alignment	
Insert arc	
Clearance checking	
Amend parameters	
End this alignment	

Construct IP is used to insert an intersection point between two separated part alignments, so that an arc may be inserted.

**Preceding element** and **following element** are separate straight elements which are extended to their intersection point.

## Edit alignment

This is similar to that described in 'Horizontal element method' except for the following:

It is possible to edit an IP alignment so that the configuration remaining is no longer suitable for the IP method. For instance removal of a straight from the middle of an IP alignment would cause this. Such edits are for the most part prohibited by the program and you should not continue in IP mode if the program warns you not to (revert to the element method).

## Move IP

IGIADS.DAT, IAD036, IAD043, IAD044

IP Alignment	Edit alignment	Move IP
Start IP X Y	Respecify element	IP X
Next IP X Y	Delete element	Y
Absolute brg Length	Reverse element	Move to X
Relative brg Length	Lengthen alignment	Y
Exist IP X Y	Truncate alignment	Recall radii (T)
Construct IP	Translate alignment	
Edit alignment	Rotate alignment	
Insert arc	Reverse alignment	
Clearance checking	Move IP	
Amend parameters	Delete links	
End this alignment		

This facility enables you to adjust an horizontal alignment defined by the IP method by moving any intersection point to a new position.

You select the IP you wish to move and define its new position.

The **Recall radii** toggle set to YES (default) enables you to reuse the radii and the transition specifications as defined for the unadjusted alignment in the adjusted alignment for all the arcs affected by the Move IP. This is done by reanalysis using each arc in turn as a free element. If the toggle is set to NO then the alignment will be left as a sequence of straight elements in the region of the move, the arcs having to be redefined using INSERT ARC.

The sequence of events is :-

1. Select the IP to be moved and its new position. Leave insert arc toggle as YES. The affected portion of the alignment is deleted and redrawn in the background colour. This “ghost” representation will eventually disappear as the calculation progresses but provides a useful reference for you to see the effect of the MOVE IP.
2. The elements of the effected portion are then redrawn as elements in their new position. You are then asked to confirm that you wish to proceed with the edit in the usual way. If so then the ghost vanishes. (This would be the end of the process if RECALL RADII was set to NO).
3. A marker then appears on the IP which has been moved and a menu displayed with the original data for the curve opposite it with the radius and transition details defined. Proceed from here uses the original data or you may adjust the radius or the transition definitions prior to proceed. The alignment is reanalysed and displayed in the usual way for ACCEPT/MODIFY/ABANDON. (Note that the alignment can be in error here if the move makes the curve not fit).

4. Once the reanalysis has been accepted the marker moves to the IP prior to the Moved IP and the process of the above paragraph is repeated for the curve opposite this. The process is then repeated again for the IP following the moved IP

The process is the same in principle but reduced in the number of operations if the IP moved is either:

- Start or end point
- Second IP
- Penultimate IP.

## Insert arc

IGIADS.DAT, IAD050

Insert arc
Given radius
Tangent length
Arc length
Through a point
Arc to arc (opp hand)

**Given radius:** places that radius arc in the alignment with transition curves as required.

**Tangent length:** places the arc of calculated radius such that the length between the tangent point on the straight and the intersection point is the specified value.

**Arc length:** places the arc of calculated radius so that the length of arc is the specified value.

**Through a point:** places the arc of calculated radius so that it passes through a specified point.

The above 3 calculations are always carried out iteratively as the possible inclusion of transitions requires this although it is accepted that some straightforward cases do have an analytical solution. The data for each of these methods accordingly requires a seed radius - an initial guess - to start the calculation running.

**Arc to arc:** enables a connection to be made between one of the neighbouring arcs and the current arc with the elimination of the straight between them. This is only available to connect arcs of opposite hand - the more common practical case.

Such a connection between same hand curves is complicated by the possibility of dual solutions but is available through the element method. This calculation is also iterative and requires a seed radius. The inclusion of an arc to arc connection precludes the use of the editing option 'Move IP' in the vicinity of this connection.

## Insert arc: given radius

IGIADS.DAT, IAD036, IAD050, IAD035

IP Alignment	Insert arc	Insert arc: given radius
Start IP X Y	Given radius	Hand of arc
Next IP X Y	Tangent length	Radius
Absolute brg Length	Arc length	Preceding trans len
Relative brg Length	Through a point	Following trans len
Exist IP X Y	Arc to arc (opp hand)	
Construct IP		
Edit alignment		
Insert arc		
Clearance checking		
Amend parameters		
End this alignment		

## Insert arc: tangent length

IGIADS.DAT, IAD036, IAD050, IAD040

<b>IP Alignment</b>	<b>Insert arc</b>	<b>Insert arc: tangent length</b>
Start IP X Y	Given radius	IP X
Next IP X Y	<b>Tangent length</b>	Y
Absolute brg Length	Arc length	Hand of arc
Relative brg Length	Through a point	Tangent length
Exist IP X Y	Arc to arc (opp hand)	Preceding transition length
Construct IP		Following transition length
Edit alignment		
<b>Insert arc</b>		
Clearance checking		
Amend parameters		
End this alignment		

## Insert arc: arc length

IGIADS.DAT, IAD036, IAD050, IAD041

<b>P Alignment</b>	<b>Arc in IP alignment</b>	<b>Insert arc: arc length</b>
Start IP X Y	Given radius	Hand of arc
Next IP X Y	Tangent length	Arc length
Absolute brg .length	<b>Arc length</b>	Preceding trans length
Relative brg .length	Through a point	Following trans length
Exist IP X Y	Arc to arc (opp hand)	
Construct IP		
Edit alignment		
<b>Insert arc</b>		
Clearance checking		
Amend parameters		
End this alignment		

## Insert arc: through a point

IGIADS.DAT, IAD036, IAD050, IAD045

P Alignment	Arc in IP alignment	Insert arc: through point
Start IP X Y	Given radius	Hand of arc
Next IP X Y	Tangent length	Point X
Absolute brg length	Arc length	Y
Relative brg length	Through a point	Seed radius
Exist IP X Y	Arc to arc (opp hand)	Preceding trans length
Construct IP		Following trans length
Edit alignment		
Insert arc		
Clearance checking		
Amend parameters		
End this alignment		

## Insert arc: arc to arc (opp hand)

IGIADS.DAT, IAD036, IAD050, IAD058

P Alignment	Arc in IP alignment	Arc to arc (opp hand)
Start IP X Y	Given radius	IP X
Next IP X Y	Tangent length	Y
Absolute brg length	Arc length	Hand of arc
Relative brg length	Through a point	Preceding transition len
Exist IP X Y	Arc to arc (opp hand)	Following transition len
Construct IP		
Edit alignment		
Insert arc		
Clearance checking		
Amend parameters		
End this alignment		

## Display parameters

See the corresponding section in 'Horizontal element method'.

## Design parameters

IAD299

Design parameters
Curve insertion (T)
Units (R)
Angular input (T)
Radius use (T)
Transition rules (T)
Transition formula (T)
Transition defined by (T)
Transition overridden by (T)
Transition default parameter
Vert align (R)
Rail design (R)
Reset params to default

**Curve insertion** is a toggle which allows you to switch between "3 IP" mode and "ALL IP" mode.

"3 IP" mode accepts data in a repetitive sequence IP-IP-Insert curve. "ALL IP" mode accepts data for all IPs and then you insert arcs in whichever sequence you wish by picking the IP opposite which the arc is to be placed. For descriptions of all the other design parameters on this menu, see 'Horizontal element method'.

# Horizontal spline method

## Introduction





The Spline Method is offered as an alternative to the Element and IP methods. It is based on the alignment being a continuously curving spline between a sequence of points.

The methods adopted in this part of ALIGNMENT are performed differently from those elsewhere. This is because a spline alignment has to be analysed in its entirety rather than being constructed from separate elements.

It is not possible to switch between the spline and the other methods. However, it is possible to create a master string by combining an element (or IP) horizontal alignment and a spline vertical alignment (and vice versa) Some theory related to horizontal splines can be found in Chapter 7 (HCUSP).

## Spline symbols

The following symbols are used at spline location points to indicate the fixity of the bearing and radius:

	Free bearing, free radius
	Free bearing, fixed radius
	Fixed bearing, free radius
	Fixed bearing, fixed radius

**Figure 6 - 22** Symbols used in spline alignments



## Spline alignment

IGIADS.DAT, IAD203

Spline alignment
Locate point(s)
Insert point(s)
Respecify point
Delete point
Analyse
Amend parameters
End this alignment

~~Locate point~~ allows you to specify control points for the cubic spline being formed, or add a new point to an existing spline.

Locate point(s) allows you to specify control points for the cubic spline being created.

Insert point(s) allows you to insert a point in an existing spline.

**Respecify point** allows you to change an existing point's location and associated parameters

**Delete point** allows you to delete an existing point.

**Analyse** performs the cubic spline calculation.

Amend parameters allows you to set design and display parameters for the cubic spline analysis.

## Locate point(s)

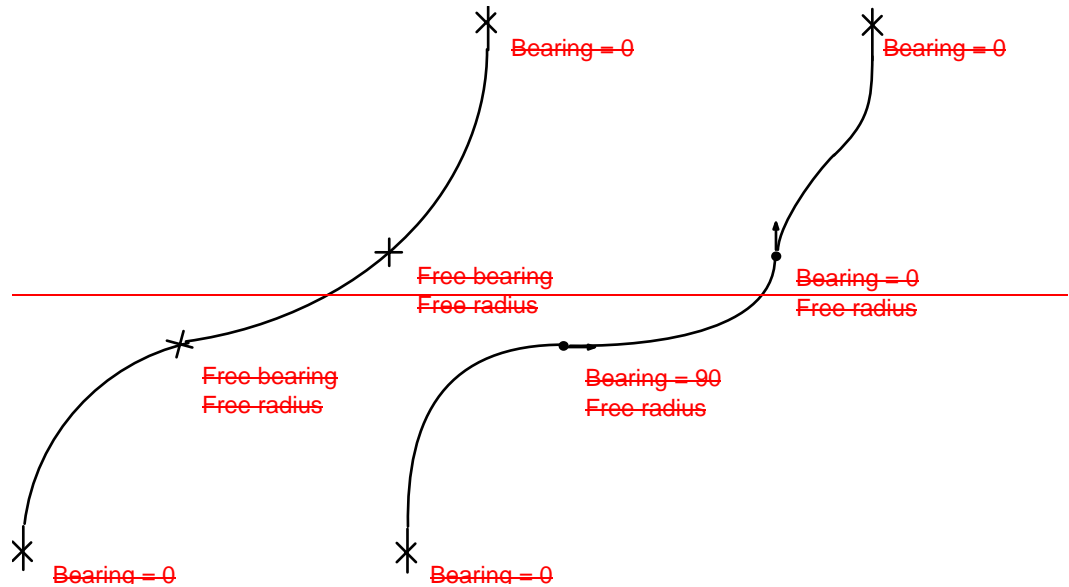
IGIADS.DAT, IAD203, IAD204

Spline alignment	Locate point
Locate point(s)	Point X
Insert point(s)	Y
Respecify point	Bearing
Delete point	Radius
Analyse	Hand of arc (T)
Amend parameters	No more points
End this alignment	

**Point X,Y** is used to locate control points defining the path of a cubic spline. By default, when you specify the location of a point, a locator symbol is drawn on the screen and Point X,Y is automatically highlighted ready for locating the next point.

You may specify a **whole circle bearing**, a **radius** and the **hand of arc** for the next point to be located. By specifying these values, you affect the way the spline will be created drawn when it is analysed. NO TAG gives an example.

- ◇ *The bearing and radius are 'free' if no values are specified, except for the first and last points where the bearing is set to 0.*
- ◇ *To enforce a straight through a point, specify a radius of 0.*



### Cubic spline – effect of bearing

If you enter a value for bearing or radius, or toggle hand of arc, you must then select 'Point X,Y' from the menu in order to locate the point.

~~Preceding point and following point are used if you wish to locate a point out of sequence. For example, if you have entered three points and then wish to place an additional point between the first and second points, select 'Preceding point', then select the first point and finally enter the location of the new point.~~

~~◇ Points can be added to analysed and non-analysed curves. In either case, you should re-analyse the points to produce the new curve.~~

~~◇ To insert an additional point, use 'Insert point(s)'.~~

~~◇ To amend an existing point, use 'Respecify point'.~~

When you have located all the points, select **no more points** which will return you to the 'Spline alignment' menu.

If you wish to produce the curve, select **Analyse**.

Insert point(s)

Spline alignment	Insert point(s)
Locate point(s)	New point X
Insert point(s)	Y
Respecify point	Precedes/Follows (T)
Delete point	Existing point
Analyse	Bearing
Amend paramters	Radius
End this alignment	Hand of arc (T)
	No more points

New point X,Y allows you to specify the location of the point to be inserted.

Precedes/follows is used to indicate where the new point is to be inserted. For example, if you have three points in a spline and wish to insert an additional point between the first and second points, specify the location of the new point, switch the toggle to 'Follows', then select the first point as the existing point.

Existing point allows you to specify the location of an existing point which precedes or follows the point to be inserted.

You may also specify a whole circle **bearing**, a **radius** and the **hand of arc** for the next point to be located. By specifying these values, you affect the way the spline will be drawn when it is analysed.

◇ The bearing and radius are 'free' if no values are specified, except for the first and last points where the bearing is set to 0.

◇ To enforce a straight through a point, specify a radius of 0.

When you have inserted all the points, select **No more points** which will return you to the 'Spline alignment' menu.

If you wish to produce the curve, select **Analyse**.

◇ Points can be inserted in analysed and non-analysed curves. In either case, you should re-analyse the points to produce the new curve.

## Respecify point

IGIADS.DAT, IAD203, IAD205

Spline alignment	Respecify point
Locate point(s)	Point
Insert point(s)	Relocation X Y
Respecify point	Bearing
Delete point	Bearing fixity (T)
Analyse	Radius
Amend parameters	Radius fixity (T)
End this alignment	Hand of arc (T)

To respecify a point, select the point, change any of its associated values and select Proceed. When you have finished respecifying points on a curve, re-analyse the curve using 'Analyse' on the 'Spline alignment' menu.

**Point** displays the point you have selected.

**Relocation X,Y** allows you to relocate the point.

**Bearing** allows you to change the bearing at the point.

**Bearing fixity** allows you to free the bearing at a point where the bearing has previously been fixed.

**Radius** allows you to change the radius at a point.

◇ *To enforce a straight through a point, specify a radius of 0.*

**Radius fixity** allows you to free the radius at a point where the radius has previously been fixed.

**Hand of arc** can be toggled at a point where a radius has been fixed.

## Delete point

IGIADS.DAT, IAD203, IAD206

Spline alignment	Delete point
Locate point(s)	Point
Insert point(s)	
Respecify point	
Delete point	
Analyse	
Amend parameters	
End this alignment	

To delete a point, select the point followed by Proceed. When you have finished deleting points on a curve, re-analyse the curve using 'Analyse' on the 'Spline alignment' menu.

## Alignment review

IGIADS.DAT, IAD207

Alignment review
Summary
Clearance
Modify
Abandon
Accept

When a spline has been analysed, the alignment review menu appears in the scrolling menu area.

**Summary:** Gives a menu summary of the alignment which has been analysed. The alignment will be highlighted on the screen. This information helps you decide whether your data needs amending.

**Clearance:** Displays the sub-menu 'Clearance checking'. This gives you the opportunity to evaluate critical points in relation to your spline by giving the distance from the point to the nearest point on the alignment.

**Modify:** If you wish to modify your alignment, select 'Modify'. You will then be returned to the 'Spline alignment' menu.

**Abandon:** This will remove the spline just analysed and will return you to the 'Spline alignment' menu.

**Accept:** If you are happy with the spline as defined it will become a permanent part of the alignment. You will then be returned to the 'Spline alignment' menu.

◇ *When the analysis of an alignment results in diagnostics an appropriate menu is displayed which tells you how many diagnostic messages have been produced, in addition to the usual information. You can display each message in turn in the diagnostic area at the top of the screen by selecting 'Display next message' in the menu, as many times as you like. If you select it more times than there are diagnostics produced, you will be returned to the first message, and so on round the cycle.*

## Display parameters

IGIADS.DAT, IAD201

Display parameters
Working colour (T)
Working style (T)
Background colour (T)
Background style (T)
Reset params to default

**Working colour:** This is the colour in which the current alignment is displayed, including the spline symbols and analysed curve.

**Working style:** This is the style in which the current alignment is displayed, including the spline symbols and analysed curve.

**Background colour:** This is the colour in which the alignment is displayed when it is not the current alignment. This facility is particularly useful in preparing preliminary designs, where you can have a red route, a green, and so on.

**Background style:** This is the style in which the alignment is displayed when it is not the current alignment.

**Reset params to default:** resets all the display parameters to the default values held in the parameter file. See Chapter 2 for a description of the parameter file.

◇ *Colours chosen in horizontal alignment will automatically be carried forward to vertical design, where they may be overridden if required.*

If you wish to save your changes and return to the 'Horizontal design' menu, select Proceed.

If you wish to cancel your changes and return to the 'Horizontal design' menu, select Quit.

The values you have chosen take effect when you proceed from the 'Horizontal design' menu. The current alignment is redrawn according to the new values.

## Design parameters

IGIADS.DAT, IAD202

Design parameters
Design speed
Minimum radius
Tolerance
Maximum RCLA
Angular input (T)
Radius use (T)
Reset params to default

The Design parameters menu enables you to specify the engineering parameters for your design.

**Design speed** is the design speed for the alignment you are designing.



**Minimum radius** is the minimum radius allowed at any point on the alignment

**Tolerance** is the maximum allowable chord-to-arc tolerance for the alignment.

**Maximum RCLA** is the maximum rate of change of lateral acceleration. This limits the amount the radius of a curve can change over a certain distance.

**Angular input/output:** There are five ways of supplying angular data and you may toggle through the alternatives until you reach your choice.

- DMS            Degrees minutes and seconds.
- DDD.DDD    Degrees and decimal degrees.
- Grad           Grads.
- Rads           Radians.
- Quad          Quadrant Bearings.

For examples of each format, refer to Chapter 2.

**Radius use:** This is a 3-way toggle which defines the way that certain menu boxes will interpret the entry of a radius. The menu boxes are all those that require entry of a radius, in horizontal design only.

The usual toggle is RADIUS, which is the default. In this position all radii are interpreted as radii.

The alternative toggles are DOC(A) and DOC(C) (DOC stands for 'degree of curvature'). Under these, all radii are interpreted as angles in the current angular input style.

Under DOC(A), the angle is that corresponding to a 100 model unit arc length.

Under DOC(C), the angle is that corresponding to a 100 model unit chord length.

These alternative toggles are offered mainly for countries that use these methods in conjunction with design tables as the standard technique for defining the radius of an arc.

**Reset params to default** resets all the design parameters to the default values held in the parameter file, except for those which are dependent upon other values. See Chapter 2 for a description of the parameter file.

# Vertical design

## Introduction

This section takes you through the process of vertical design using major option ALIGNMENT.

There are three methods for designing alignments:

- the element method
- the intersection point (IP) method
- the cubic spline method

In the **element** method you assemble fixed, floating and/or free parabolic curves and grades into an alignment in any sequence.

In the **IP** method you build the vertical alignment as a sequence of grade-curve-grade-curve-grade, and so on.

In the **cubic spline** method you locate points to define a curve and then analyse the points to produce a spline.

Vertical alignment design is similar in operation to horizontal design except that the backcloth drawing is a long section rather than a plan. However, in vertical design there are also considerations of whether to generate ground profiles automatically from within ALIGNMENT, or whether to generate them independently through other parts of MOSS.

You can enter and leave vertical alignment at any stage and then restart your design on a later occasion. Cross references between the selected horizontal alignment and its vertical drawing maintain the integrity of the stored information.

Vertical design involves the following steps:

- Backcloth drawing
- Data entry
- Analysis

## Backcloth drawing

There can be many horizontal alignments within a GDS and there can be as many automatically designed vertical alignments. The vertical drawing is created as a separate sheet on the same DPF as the horizontal. You move

between horizontal and vertical design, accessing the different sheets of the DPF using the SHEET facilities.

The backcloth and ground profile are not stored on the design model; they are deleted on exit from the vertical design, but not deleted from the GDS or the dpf.

Additional profiles may be added to give collinear profiles through substrata models and profiles at constant offset from the horizontal alignment. Offset profiles will usually be through the surface model although there is no reason why they should not be through substrata models.

The drawing style is provided by the VERTAD macro (which may be edited), and you may define scales and extents of the drawing. The section(s) are not stored, and are for use only within ALIGNMENT.

There are two methods of preparing the backcloth drawing:

- Preparing a long section drawing independently of major option ALIGNMENT
- Using ALIGNMENT, derive a long section based on a horizontal alignment and draw it automatically.

### Independent ground long section

The long section generated in ALIGNMENT may not be a suitable backcloth for vertical design for some users. If this is the case, you can create a user defined long section.

In order to use this feature it is necessary to create a master string in either ALIGNMENT or by using HALGN. This string is then used as a reference string in a SECTION option to generate the existing ground profile.

Once the ground profile string has been generated, a user defined long section drawing can be created using the DRAW options. The maximum and minimum levels displayed must be sufficient to accommodate the vertical design.

With the long section displayed it is possible to use ALIGNMENT to create and edit the vertical profile. The relevant horizontal profile must be in the GDS model, so if HALGN has been used the geometry string must be retrieved into the GDS model (refer to Retrieving an Alignment, Ch.6, page 3).

To create a vertical profile, select *Vertical design* in the **Alignment main menu** followed by *Create new alignment* and type the horizontal alignment name. Vertical design will now be possible.

### Automatic ground long section

This is the most straightforward and rapid method, but the horizontal alignment must have been designed using ALIGNMENT.

First you select the horizontal alignment that you wish to design, and the ground model or triangulation through which the section is to be taken.

On completing the horizontal design process you will return to the **Alignment main menu**.

When you wish to proceed to vertical design you select *Vertical design*, which gives you the **Begin vertical design** menu. You then select the alignment for which you require a ground profile.

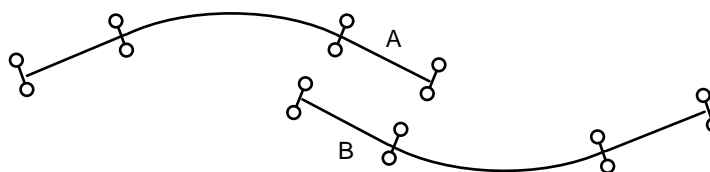
## Data entry

The relationship between the horizontal design, its ground profile, and vertical design is held within the program. While this confers advantages of consistency and correctness it does impose the restriction that only one vertical design can be referenced to one horizontal.

When data is entered for elements in vertical alignment the direction of the vertical element is obtained from the chainages given rather than from the order of data entry. For instance, the following two specifications for a fixed gradient are identical:

Element	Name	A001
Point 1	Ch	200.00
	Level	133.91
Point 2	Ch	100.00
	Level	125.63
Element	Name	A001
Point 1	Ch	100.00
	Level	125.63
Point 2	Ch	200.00
	Level	133.91

Alignments are arranged in increasing chainage, which restricts the ways in which alignments can be connected. All elements prior to analysis and all past alignments are independent. Thus it is feasible to define part alignment as below:



**Figure 6 - 29 Example - part alignment**

However it would not be possible to connect A to B or vice versa because of the overlapping chainages.

Practical considerations dictate the majority of vertical alignments. Work is usually carried out on longitudinal profile drawings on which the vertical scale is exaggerated compared with the horizontal. All data are entered with reference to real world levels and chainage and the transformations to the exaggerated scale are handled automatically.

Even with vertical exaggeration the majority of vertical designs will be carried out on drawings that are long but not very high. This is no problem for MOSS, and is best handled by using windows. (One convenient way is to pre-define a set of similarly-sized overlapping windows along the scheme prior to any design work being done).

### Analysis

Alternative solutions are more significant in vertical alignments than in horizontal and are associated with floating curves as well as free curves. This should not cause any difficulties because the option to examine the alternative is always available. If an analysis gives the unwanted solution then one menu selection will give the alternative. Further selection of the same menu returns you to the first solution. In certain cases the first solution may be in error whilst the alternative is valid (or vice versa).

Any solution which places points of alignment outside the picture is deemed in error. Thus it is important to provide sufficient space by manipulating the extreme levels as the backcloth picture is drawn to allow points and curves to fit. Elements without defined end points (that is, grade through point and gradient) are clipped at the picture edges.

Having constructed the background framework on which to build your vertical alignment design you can begin the design itself.

### Begin vertical design

IGIADS.DAT, IAD130

Begin vertical design
Alignment
Intersect annotation (T
No. of intersection:
Clear current annotation

**Alignment** is the name of the alignment for which you require a ground profile.

If **Intersect annotation** is set to YES, on Proceed the 'Alignment annotation' menus will be displayed so that intersection points on the vertical alignment can be annotated.

If Intersect annotation is set to 'NO', on Proceed you will be required to select a ground profile if this is a new design, or to indicate whether you wish to amend or delete the existing design.

**No. of intersections** is the number of intersections currently annotated.

**Clear current annotation** removes all the intersect annotation from the vertical profile.

## Intersect annotation

Various symbols may be used to annotate the points where any string or element intersects the alignment being designed. The annotation is displayed on the vertical profile.

- ◇ *The level at an intersection is calculated by interpolation. If null levels make it impossible to calculate a level, a vertical line is drawn from the ground profile to the bottom of the section drawing area.*

## Symbol at intersect

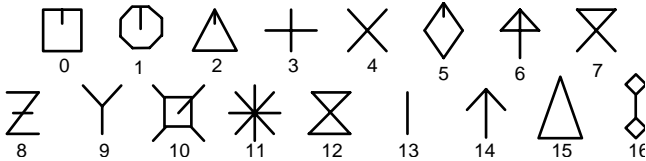
IGIADS.DAT, IAD284,IAD285

Intersect annotator	Symbol at intersect
Symbol at intersec	Intersecting feature
Macrosymbol at intersec	Approx X Y
Line at intersects	Symbol number
Macroline at intersect:	Symbol colour (T)

**Intersecting feature** is the string or element which intersects the alignment being designed.

**Approx X and Y** are the approximate coordinates of the point of intersection of the intersecting feature with the alignment being designed.

**Symbol number** is the number of the standard symbol used to annotate the point of intersection on the vertical profile.



See also NO TAG

Figure 6 - 30 Standard centred symbols

**Symbol colour** is a toggle which allows you to select the colour of the symbol.

### Macrosymbol at intersect

IGIADS.DAT, IAD284,IAD286

<b>Intersect annotator</b>	<b>Macrosymbol at intersect</b>
Symbol at intersec	Intersecting feature
Macrosymbol at intersec	Approx X Y
Line at intersect:	Macrosymbol name
Macroline at intersect:	Macrosymbol colour (T)

**Intersecting feature** is the string or element which intersects the alignment being designed.

**Approx X, Y** are the approximate coordinates of the point of intersection of the intersecting feature with the alignment being designed.

**Macrosymbol name** is the name of the macrosymbol used to annotate the point of intersection on the vertical profile.

**Macrosymbol colour** is a toggle which allows you to select the colour of the macrosymbol.

## Line at intersects

IGIADS.DAT, IAD284,IAD287

Intersect annotator	Line at intersects
Symbol at intersec	Intersecting feature 1
Macrosymbol at intersec	Approx X Y
Line at intersects	Intersecting feature 2
Macroline at intersect:	Approx X Y
	Line style (T)
	Line colour (T)

**Intersecting features 1 and 2** are the strings or elements which intersect the alignment being designed. The line displayed on the vertical profile is drawn between the two intersection points.

**Approx X and Y** are the approximate coordinates of the points of intersection of the intersecting features with the alignment being designed.

**Line style** is the style used to draw the line on the vertical profile, eg, solid, dashed etc.

**Line colour** is a toggle which allows you to select the colour of the line.



## Macroline at intersects

IGIADS.DAT, IAD284,IAD288

Intersect annotator	Macroline at intersects
Symbol at intersec	Intersecting feature 1
Macrosymbol at intersec	Approx X Y
Line at intersects	Intersecting feature 2
Macroline at intersect:	Approx X Y
	Macroline name
	Macroline colour (T)

**Intersecting features 1 and 2** are the strings or elements which intersect the alignment being designed. The line displayed on the vertical profile is drawn between the two intersection points.

**Approx X and Y** are the approximate coordinates of the points of intersection of the intersecting features with the alignment being designed.

**Macroline name** is the name of the macroline used to annotate the point of intersection on the vertical profile.

**Macroline colour** is a toggle which allows you to select the colour of the macroline.

Example

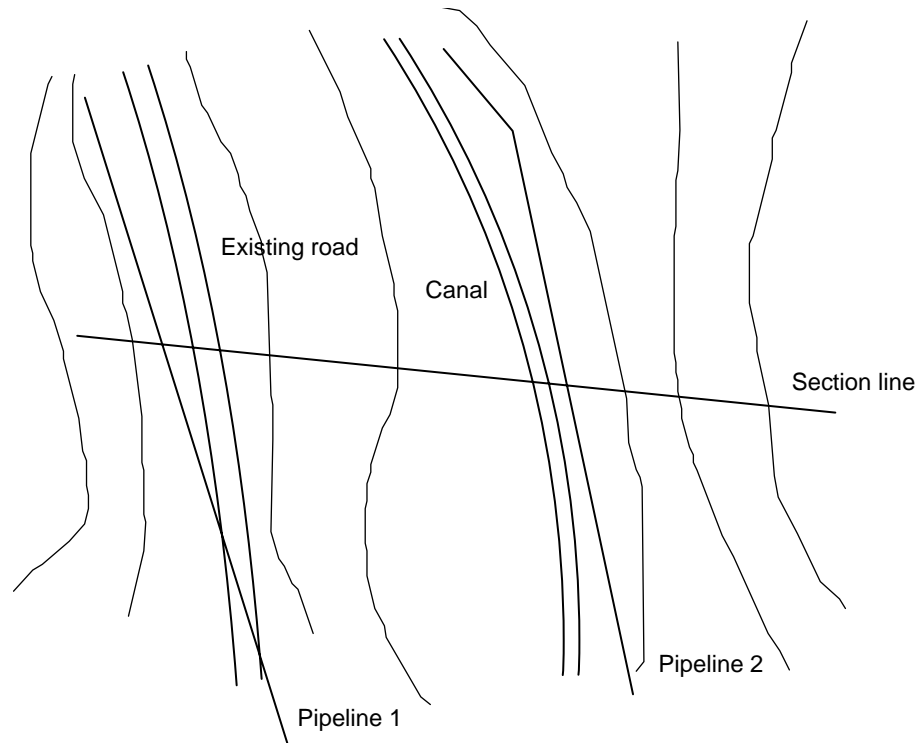


Figure 6 - 31 Horizontal alignment

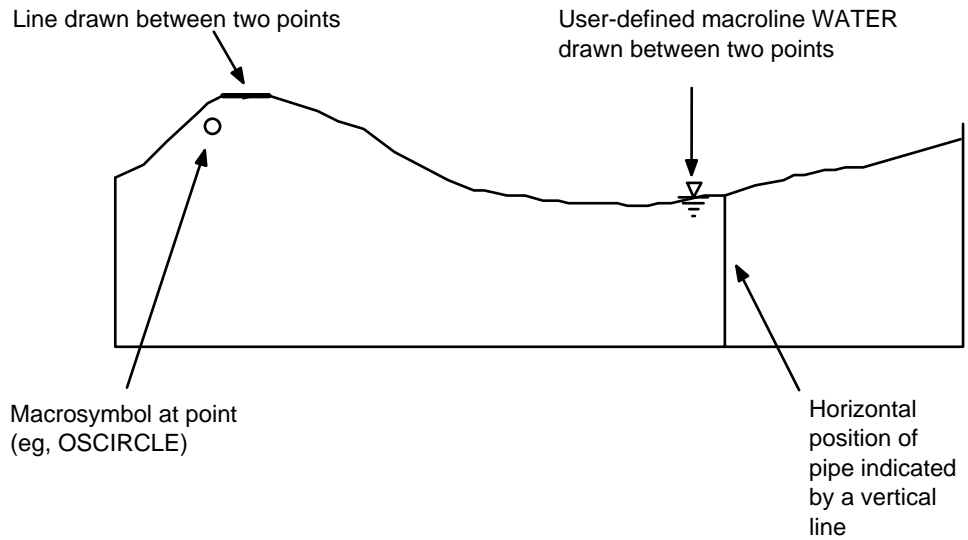


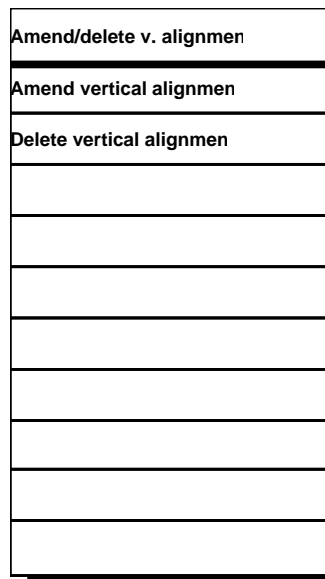
Figure 6 - 32 Vertical alignment with annotation

## Amend/delete vertical alignment

If an existing horizontal alignment is modified, you may wish to amend the corresponding vertical alignment rather than delete it.

- ◇ *This menu is only displayed if both a horizontal and its corresponding vertical alignment exist and the horizontal alignment has been modified since the vertical alignment was created.*

IGIADS.DAT, IAD200

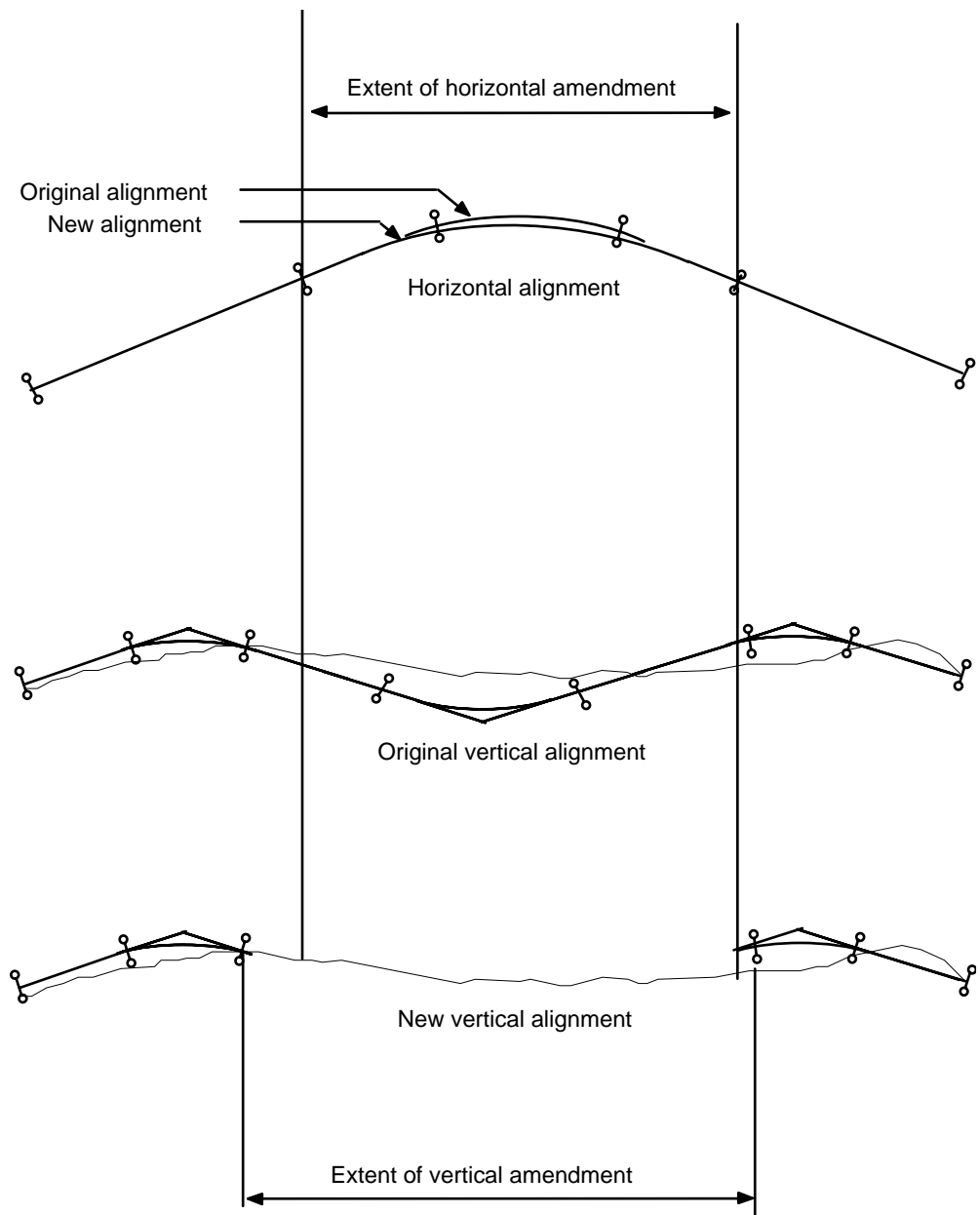


To modify an existing vertical alignment, select **Amend vertical alignment** and proceed. When the ground profile and existing vertical alignment are drawn, only those portions of the vertical alignment lying upon the unmodified part of the horizontal alignment are shown. You can then complete the design according to the modifications made to the horizontal alignment.

A different method of truncating the existing vertical alignment is used depending upon the current design method.

- Element method: the vertical alignment is truncated back to the first vertical tangent points lying outside the extent of the modified part of the horizontal alignment.
- IP method: the vertical alignment is truncated back to the first intersection points lying outside the extent of the modified part of the horizontal alignment.
- Spline method: the vertical alignment is unanalysed and only the location points lying outside the modified part of the horizontal alignment are retained.

To create a completely new vertical alignment, select **Delete vertical alignment** and proceed. The existing vertical alignment is deleted and only the ground profile is drawn.



**Figure 6 - 33 Amending a vertical alignment - element method**

## Ground profile

IGIADS.DAT, IAD149

Ground profile
Alignment
Ground/Triangle model mode
Triangulation string
Chainage interval
Colour (T)
Linestyle (T)
Secondary interp tolerance
Secondary interp offset

You usually specify the ground model for the section by selecting from the screen one of the strings in that model. If you have specified a triangulation model you must select the triangulation string box. . You must also specify a chainage interval at which the profile will be calculated (a default of 10 is given but this can be overridden). You can also select the colour and linestyle in which the profile will be drawn.

For the first profile selected in the sequence (which is by convention that coincident with the horizontal alignment at the ground surface) you may give values for secondary interpolation tolerance and offset. These have the same significance as if they were set from minor option 017. The default values displayed will be those set from minor option 017 or the system defaults.

- ◇ *The minor option 017 values are reset to their entry values when you exit from major option ALIGNMENT.*
- ◇ *Offset and collinear profiles are calculated using the values set for the design line.*

## Profile details

IGIADS.DAT, IAD151

Profile details
Add collinear profile
Add offset profile
Draw profile(s)

**Add collinear profiles** allows you to add profiles coincident in plan with the horizontal alignment but taken through different models (such as substrata models).

**Add offset profiles** allows you to add profiles which are offset from the horizontal alignment to give a visual indication of sidelong ground.

When you have designated all the collinear and offset profiles you require, select **Draw profiles(s)** to invoke the automatic sectioning process.

# Collinear/offset profile

IGIADS.DAT, IAD150

Collinear/offset profile
Alignment
Ground mode
Chainage interval
Colour (T)
Linestyle (T)
Offset
Side (T)

**Alignment** is the name of the associated horizontal alignment

## Profile parameters

When the sectioning is complete the **Profile parameters** menu is displayed.

IGIADS.DAT, IAD143

Profile parameters
Horizontal scale
Vertical scale
Minimum chainage
Maximum chainage
Minimum level
Minimum displayed level
Maximum level
Maximum displayed level

This gives default horizontal and vertical scales, which you may change to give any reasonable vertical exaggeration. The start and end chainages



along the profile are given, as are the maximum and minimum levels found over all the sections processed. The maximum and minimum levels that will be displayed are also shown and these may be altered to give reasonable amounts of working space above and below the section.

To draw the section(s) select PROCEED.

## Vertical design

IAD301

Vertical design
Alignment name
Design method (T)
Background colour (T)
Display parameter:
Design parameter:

**Alignment name** is the name of the alignment to be designed or modified.

**Design method** is a toggle which allows you to select one of the three methods of design.

**Background colour** is the colour in which the alignment is displayed when it is not the current alignment. This facility is particularly useful in preparing preliminary designs, where you can have a red route, a green, and so on.

The colour you specify here as the background colour becomes the default. In other words, the background colour field in the 'Display parameters' menu is also updated to reflect the colour you choose here.

**Display parameters** allows you to check or modify the default display parameters used in ALIGNMENT.

**Design parameters** allows you to check or modify the default design parameters used in ALIGNMENT.

# Vertical element method

## Introduction

This section takes you through the process of vertical design using the element method. Using this method you assemble fixed, floating and/or free parabolic curves and grades into an alignment in any sequence.

◇ *Some of the menus which appear within Vertical design (Element) are very similar to those which appear in Horizontal design (Element) and are not documented separately.*

Once all the elements are in place, you may review the alignment to see if it is acceptable. If it is not, you may modify the alignment until it is acceptable, or abandon the alignment.

On completion of the alignment, you may return to the ALIGNMENT main menu.

## Point selection

There are several methods of selecting the points to include in your alignment analysis, and these are described in the section 'Selection Methods'.

## Chainages

At this stage of fixing elements, all chainages are only local chainages. As a sequence of elements is combined, the program automatically reassigns chainages to achieve consistency. Later when you derive your M-string you can choose your chainage datum point and assign a chainage to it.

## Element alignment

IGIADS.DAT, IAD104a, IAD104

<b>Element alignment</b>
Fix grade
Fix curve
Float grade
Float curve
Free grade
Free curve
Design parameters
Edit alignment
Specials
Clearance
End this alignment

**Element alignment** is the menu at the head of a family of menus by which you calculate the position of the elements in your alignment. The element method in vertical design is similar to the element method in horizontal design.

For example if you were designing an alignment manually by linking grades and parabolic curves, you would sketch out your alignments initially on a ground profile with railway curves. With ALIGNMENT, instead of the backcloth paper drawing, you have the backcloth drawing on your graphic display. You then position your curves and grades with varying degrees of fixity until you feel you have the required solution. The program automatically computes the arithmetic and displays the geometry superimposed on your drawing.

An element is either a straight grade or a parabolic curve. You specify each element in one of three ways: fixed, floating or free.

- **Fixed element:** A fixed element is one that is fully and independently defined. For example, a curve defined as passing through three distinct points is uniquely defined and is considered a fixed element. Similarly a grade defined by a point and level with an associated gradient is uniquely defined and would be considered a fixed element.
- **Floating element:** An element defined by two geometric constraints is a floating element. This allows one degree of freedom. The element becomes fully defined by relating it to an adjacent element in the alignment. For example, a floating grade defined as passing through a point would be rotated until it is tangential to an adjacent curve.
- **Free element:** If only one item of geometric information is available then there are two degrees of freedom and the element is known as a

free element. The location of the element is resolved by considering the geometric elements to either side of it. For example, the focus coordinates of a parabola which has only its curve parameter explicitly given will be moved until the curve is tangential to the curves either side of it.

You add elements one at a time. If they are fixed elements you give all the geometric information, whereas for floating elements you give less geometric data, but you define the adjacent element to 'float' on to. For free elements you give both the adjacent elements.

A point worth noting is that you don't have to begin at the beginning of the alignment and proceed in the direction of increasing chainage. Also, an alignment can consist of several part-alignments, although they must be joined to form a wholly-continuous alignment before a master string can be generated.

## Free curve - defined length

IGIADS.DAT, IAD109,IAD109a

Defined length
Alignment element name
Preceding element
Following element
Curve sense (R)
Use def len
Of
Specify len
Use K len
Of
K value (R)
% Grade diff (R)
Specify K

Whenever a free curve is to be specified by length in vertical element method, the above menu is displayed.

**Preceding** and **Following Elements** must always be straight. Once picked, the appropriate values will automatically be inserted into the relevant boxes.

The sense of the curve is determined by the surrounding geometry after selecting the preceding and following elements.

**Use def len:** Select this box if you wish to use the default curve length specified in the design parameters menu. The appropriate default is displayed according to the sense of the curve.

**Specify length:** Select this box to specify a curve length different from the default.

**Use K len:** The program will tell you the length of curve required to satisfy the K value defined in your current design parameters and you may use this directly by picking the Use K length box. For your information the K value used and the %Grade Difference are also displayed. Alternatively you may specify a K value which will be used in the design. K values are available in addition to the existing methods of curve definition available in this menu.

## Edit alignment

The following facilities are available with both the element method and the IP method, except for *Split alignment* which is not available with the IP method.

IGIADS.DAT, IAD156

Edit alignment
Respecify element
Delete element
Lengthen alignment
Truncate alignment
Raise alignment
Split alignment
Delete links
Respecify link
Swop link
Move IP

When a vertical alignment is complete or partially complete you can edit to revise the geometry.

You can edit:

- elements prior to analysis
- alignments or part alignments
- individual links within alignments after analysis.

All edits involving alignments, part alignments or links have a 'safety catch' in that the results of your edit will be displayed, after which you can either accept them and make them permanent or return to the position prior to the edit. The edits for vertical alignments offer similar facilities to those for horizontal alignments although there are certain horizontal editing facilities which are inappropriate in vertical and hence are omitted.

**Respecify element:** Respecifies an element which has not yet been included within an alignment. This process will redisplay the original data for the element and any data items can be amended.

**Delete element:** Deletes an element which has not been included within an alignment.

◇ *Split alignment is not available with the IP method.*

## Lengthen alignment

Extends an alignment.

IGIADS.DAT, IAD158

Lengthen alignment
From ch
level
Lengthen by (chainage)
Lengthen to chainage
Lengthen to level



Figure 6 - 28 Original alignment

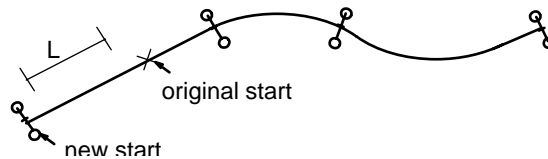


Figure 6 - 29 Lengthen by given length

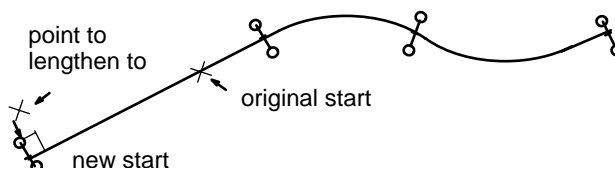


Figure 6 - 30 Lengthen to a point

**From:** select the tangent point at the start or end, depending upon which needs to be extended.

You can extend:

- by chainage, using the standard data selection methods.
- to a chainage, using the point selection methods. The alignment will be extended to the chainage selected.
- to a level, using the point selection methods. The alignment will be extended until it attains the level selected.

## Truncate alignment

This is the direct converse of lengthen alignment and the same principles apply. In addition if the amount by which the alignment is truncated is greater than one or more links, those will be deleted from the alignment.

IGIADS.DAT, IAD159

Truncate alignment
From ch
level
Truncate by (chainage)
Truncate to chainage
Truncate to level

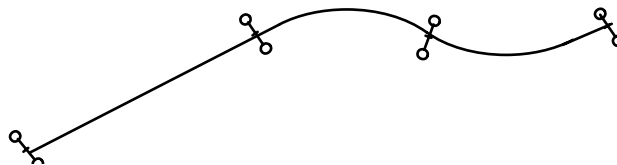
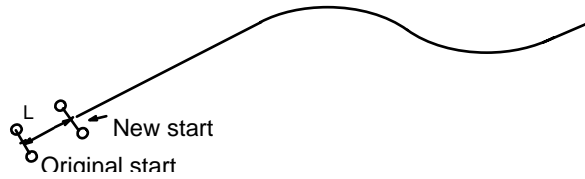
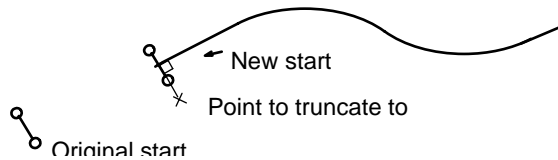


Figure 6 - 31 Original alignment



**Figure 6 - 32 Truncate by distance**



**Figure 6 - 33 Truncate to a point**

**From:** select the tangent point at the start or end depending upon which needs to be truncated.

You can truncate:

- by chainage, using the standard data selection methods.
- to a chainage, using the point selection methods. The alignment will be truncated to the chainage selected.
- to a level, using the point selection methods. The alignment will be truncated until it attains the level selected.

## Raise alignment

This enables you to change the levels along a complete alignment or a part alignment. Levels may be changed up or down. This is a translation of the alignment and does not affect whatsoever the internal geometry (radii, m-values and gradients) of the alignment.



IGIADS.DAT, IAD160

Raise alignment
Raise by
Point ch
level
Raise to level
Part alignment

**Raise by:** This enables you to input a a level difference by which the alignment is to be raised (input a negative value to drop the alignment).

**Point:** Select a tangent point to a reference point for the *Raise* operation.

**Raise to level:** The level at which the reference point will be after the *Raise* operation.

**Part alignment:** Pick this box if the *Raise* operation is to apply to only a part alignment. You will then need to pick the part alignment to which the *Raise* applies.

## Split alignment

This enables an additional start and an additional end point to be inserted within a vertical alignment at a specific chainage. This also involves the automatic generation of an additional input element. The consequence of this is a single alignment split into two part alignments which can be useful for subsequent editing.

- ◇ *It is not possible to SPLIT an alignment when using the IP method of design.*

IGIADS.DAT, IAD161

Split alignment
Split chainage

**Split chainage:** Select the chainage (using PSMs if required) to specify the point where the vertical alignment will be split.

## Delete links

IGIADS.DAT, IAD077

Delete links
Single link
Delete from Ch
Level
Delete to Ch
Level

This enables you to delete one or more links from the vertical alignment that is, the alignment between tangent points.

In doing this some of the input elements used in developing the deleted portion will be deleted from the screen whilst others remain (depending on their original fixity). Any unwanted remaining elements may then be deleted using *Delete Element*, or respecified using *Respecify Element*.

From this menu you use either *Single link* alone or *Delete from* and *Delete to* in sequence.

**Single link:** Pick one link (portion of alignment between adjacent tangent points) from the screen for deletion.

**Delete from:** Pick the tangent point from which the link deletion is to commence.

then

**Delete to:** Pick the tangent point at which the link deletion ends.

## Respecify link

This editing facility works in the same way as the horizontal respecify link. A link is selected from the vertical alignment and data representing the link as a free element is displayed (regardless of its input status). End links are displayed as floaters. The parameters defining the element may then be changed and the alignment reanalysed with the amended element as a free. This reanalysis is subject to an ACCEPT/MODIFY/ABANDON procedure. A more detailed explanation of this is given in the section on horizontal respecify link.

IGIADS.DAT, IAD175

Respecify link
Link

## Swop link

This editing facility works in the same way as the horizontal swop link. An element is defined for inclusion in a vertical alignment to replace one already included in the alignment. Swop link facilitates this by replacing the original element with the new one which is considered fixed in its defined position. Adjacent elements are automatically given sufficient freedom to move to connect with the new element.

The process involves usually 2 reanalyses of the alignment and each of these is subject to an ACCEPT/MODIFY/ABANDON procedure. A more detailed explanation of this is given in the section on horizontal swop link.

IGIADS.DAT, IAD089

Swop link
Link to be swopped
Replacement element

## Move IP

This facility enables you to adjust a vertical alignment defined by the IP method by moving any intersection point to a new position.

IGIADS.DAT, IAD060

Move IP
IP Ch
level
Move to Ch
level
Recall CP (T)

You select the IP you wish to move and define its new position. The Recall CP toggle set to YES (default) enables you to reuse the curve parameters as defined for the unadjusted alignment for the adjusted

alignment for all the curves affected by the Move IP. This is done by reanalysis using each curve in turn as a free element. If the toggle is set to NO then the alignment will be left as a sequence of grade elements in the region of the move, the curves having to be redefined using INSERT CURVE.

The sequence of events is :-

Select the IP to be moved and its new position. Leave toggle as YES. The affected portion of the alignment is deleted and redrawn in the background colour. This “ghost” representation will eventually disappear as the calculation progresses but provides a useful reference for you to see the effect of the Move IP.

The elements of the effected portion are then redrawn as elements in their new position. You are then asked to confirm that you wish to proceed with the edit in the usual way. If so then the ghost vanishes. (This would be the end of the process if Recall CP was set to NO).

A marker then appears on the IP which has been moved and a menu displayed with the original data for the curve opposite it with the CP defined. Proceed from here uses the original data or you may adjust the CP prior to proceed. The alignment is reanalysed and displayed in the usual way for ACCEPT/MODIFY/ABANDON. (Note that the alignment can be in error here if the move makes the curve not fit).

Once the reanalysis has been accepted the marker moves to the IP prior to the Moved IP and the process of the above paragraph is repeated for the curve opposite this. The process is then repeated again for the IP following that moved.

The process is the same in principle but reduced in the number of operations if the IP moved is :-

- Start or end point
- Second point
- Penultimate point.

## Special geometry

IGIADS.DAT, IAD104, IAD155/IAD171

Element alignment	Special geometry
Fix grade	Single element alignment
Fix curve	Discontinuous connection
Float grade	
Float curve	
Free grade	
Free curve	
Design parameters	
Edit alignment	
<b>Specials</b>	
Clearance	
End this alignment	

**Single element alignment:** When only a single element constitutes a complete alignment you design the alignment using Single element alignment. You will be prompted to select the element to include in your alignment and this will then be drawn as the alignment.

**Discontinuous connection:** Allows you to connect two grades together with no curve between them. The grades are extended or truncated as appropriate to the point where they intersect.

## Alignment review

IGIADS.DAT, IAD051

Alignment review
Summary
Clearance
Modify
Abandon
Accept

As each element is resolved it is superimposed on the drawing and a summary appears in the SMA. From this information you can decide if your data needs amending.

**Summary:** Gives a menu summary of the alignment which has been analysed. The alignment will be highlighted on the screen.

**Clearance:** Displays sub-menu (see below). This facility gives you the opportunity to evaluate critical points in relation to your element by giving the vertical distance from the point to the nearest point on the alignment. If you decide that a clearance is not satisfactory you can modify your element.

**Modify:** If you wish to modify your alignment, and so select 'Modify', you will be presented with a menu defining data for the free or floating element in the analysis and you change whichever data item(s) you feel is necessary.

**Abandon:** This will remove reference to the element definition and will return you to the Next element menu.

**Accept:** If you are happy with the element as defined it will become stored on the GDS. You can then go on to define the next element.

- ◇ *Free and floating curves can give rise to 'alternative solutions'. If an alternative solution is possible the Alternative solution item will appear in the Alignment review menu. Select this item to get the alternative solution, and select it again to return to the original.*
- ◇ *When the analysis of an alignment results in diagnostics an appropriate menu is displayed which tells you how many diagnostic messages have been produced, in addition to the usual information. You can display each message in turn in the diagnostic area at the top of the screen by selecting 'Display next message' in the menu, as many times as you*

*like. If you select it more times than there are diagnostics produced, you will be returned to the first message, and so on round the cycle.*

## Display parameters

IGIADS.DAT, IAD102, IAD102

Display parameters
Elements (T) (T)
Grades (T) (T)
Hog Curves (T) (T)
Sag Curves (T) (T)
Background (T) (T)
Vertical TPs (T)
Direction Markers (T)
Horizontal TPs (T)
Vertex Markers (T)
Reset params to default

In putting together a vertical alignment with major option ALIGNMENT, first you set up the display details, then you specify the design parameters, and only then do you position the alignment.

So first, for each alignment you can choose how each component is displayed.

**Elements, grades, hog curves and sag curves** are drawn in the line colour and style that you define here.

**Background:** This is the colour in which the alignment is displayed when it is not the current alignment. This facility is particularly useful in preparing preliminary designs, where you can have a red route, a green route, and so on.

**Vertical TPs, direction markers and vertex markers:** You can choose whether to display the symbols annotating certain key points on your alignment. The symbols show the positions of vertical tangent points and the curve vertices. Each of these symbols may be either visible or invisible, and this is selected on a toggle basis.

**Reset params to default** resets all the display parameters to the default values held in the parameter file. See Chapter 2 for a description of the parameter file.



## Design parameters

IGIADS.DAT, IAD127a, IAD127b

Design parameters	
Curve insertion	(T)
Curve Parameter	(T)
Extreme CP Hog	
Extreme CP Sag	
Max gradient	
Min gradient	
Def CP Hog	
Def CP Sag	
Min C've Len	
Def Len Hog	
Def Len Sag	
K values	(T)
Design speed	
Crest criterion	(T)
Reset param's to default	

**Curve parameter usage:** The parabolic elements making up your vertical alignment can be defined by giving either the vertex radius or the M-value. The generic term given throughout the menus to either of these is the *curve parameter (CP)*. By toggling, you can select the curve parameter to be the Radius or the M value. The default and check values will then change accordingly.

**Extreme CP Hog and Extreme CP Sag:** The extreme values of hog and sag curve parameters are used throughout vertical ALIGNMENT as values against which calculated curve parameters are checked to ensure they are within an allowable range.

The default for extreme CP is zero. This is a special case which causes the system to not carry out the range checking on curve parameters.

**Max gradient and Min gradient:** The gradient limits are used throughout vertical ALIGNMENT as values against which gradients are checked to ensure they are within an allowable range.

For floating or free elements (not fixed), as you give the information for each element ALIGNMENT analyses the alignment in the vicinity of the floating or free element. You develop the alignment by grafting on new elements connected by free or floating elements. The data defining the geometry constraints can be selected from among all the background data.

The **Default Hog** and **Sag** curve parameters are used in the element method for vertical alignments and are accessed as defaults for every curve on the alignment.

**Min C've Len:** A warning will be given if any curve has a length smaller than this value.

**Def Len Hog** and **Def Len Sag**: are the default Hog and Sag parameters used in the element method for vertical alignments and are accessed as defaults for every curve on the alignment.

**K values**: Select the design standard to which you wish to work either UK (KmPH) or AASHTO (MPH).

**Design speed**: Type the design speed in KmPH (UK) or MPH (AASHTO) in the ranges 40 to 120. The program will adopt this speed or if you specify a value in the middle of the speed range then the nearest lower standard speed will be used.

**Crest criterion**: toggle between Overtake, Desmin, or Absmin. Where Overtake is overtaking distance, Desmin is the minimum desirable sight distance and Absmin is the absolute minimum sight distance; and you selection is the criterion for designing crest curves. (Default = desirable minimum).

◇ *The program has built in K values extracted from the standards listed above. There is also the opportunity to define individual K values as each curve is designed. The K value units for the UK are metres and for AASHTO feet. These units will be converted using a conversion factor of 0.3048 metres = 1 foot if the Linear measure units are set contrary to the design standard (UK or AASHTO). Wherever a K value can be used its value is displayed.*

**Reset params to default** resets all the design parameters to the default values held in the parameter file, except for those which are designated as special toggles. See Chapter 2 for a description of the parameter file.

# Vertical IP method

## Introduction

This can only be used to design vertical alignments that consist of a grade-curve-grade-curve-grade sequence. It uses the intersection points between the adjacent grades as a reference for specifying the curves in between.

There are two ways of implementing the IP method:

- 3 IPs: You give the data for a pair of adjacent grades, and then you give data for the curve opposite their intersection point; and so on in this fashion throughout the alignment.
- All IPs: You give data for as many grades as are required; you then define the curves between the grades in any convenient sequence.

◇ *Some of the menus which appear within Vertical design (IP) are very similar to those which appear in Vertical design (Element) and are not documented separately.*

## IP alignment

IGIADS.DAT, IAD164, IAD164

IP alignment	IP alignment
Start IP ch	level
level	Construct IP
Next IP ch	Edit alignment
level	Insert curve
Absolute grad	Clearance
Length	Design parameters
Relative grad	End this alignment
Length	
Exist IP ch	
level	

The above menu is used for methods 1 and 2 but with variations on the highlighting sequence between the methods.

**Start IP:** This is the first IP in a sequence of elements grade/curve/grade etc.

**Next IP:** This is the IP following the one previously defined. It is requested by the highlighting sequence according to the method of operation.

**Exist IP:** This enables you to begin a sequence of grades and curves with *Start IP* as an already existing IP in the alignment.

**Construct IP:** This enables the grades at either end of sections of parts of an alignment to be extended to form an IP between them.

**Edit alignment:** This accesses the vertical alignment editing options, which are commonly used with the element method.

**Insert curve:** This is used to insert a curve 'opposite' an IP. Although this is mostly used with method 2, it can be used with method 1 if, say, a curve has been deleted from the alignment.

**IP PSM:** *Exist IP, Construct IP* and *Insert Curve* invoke IP PSM automatically, so that the IP nearest the point selected is returned.

## Curve in IP alignment

IGIADS.DAT, IAD172, IAD172

Curve in IP alignment	Curve in IP alignment
Curve sense	Use K len
Use def len	Of
Of	K value
Use def CP	%Grade diff
Of	Specify K
Specify len	
Specify CP	
No curve	
Asym curves	
Use K len	

Whenever a curve is to be specified in an IP alignment the above menu is displayed and gives the sense of the curve required.

**Use def len:** Select this box if you wish to use the default curve length specified in the design parameters menu. The default is displayed according to the sense of the curve in question.

**Use def CP:** Select this box if you wish to use the default CP (Curve parameter) specified in the design parameters menu. The default is displayed according to the sense of the curve in question and whether CP is radius or M.

**Specify length:** Select this box to specify a curve length different from the default.

**Specify CP:** Select this box to specify a CP different from the default.

**No curve:** This box allows you to include a discontinuous connection - that is, no curve at the IP.

**Asym C'ves:** This allows you to insert two curves of different lengths opposite an IP. The length of the curves is defined in a separate menu and their insertion is a two stage process. Firstly fixative that at a lower chainage to the preceding grade, and then inserting the second as a free curve between that just fixed and the following grade.

**Use K len:** The program will tell you the length of curve required to satisfy the K value defined in your current design parameters and you may use this directly by picking the Use K length box. For your information the K value used and the %Grade Difference are also displayed. Alternatively you may specify a K value which will be used in the design. K values are available in addition to the existing methods of curve definition available in this menu.

## Display parameters

See the corresponding section in 'Vertical element method'.

## Design parameters

Design parameters
Curve insertion (T)
Curve parameter (T)
Extr CP Hog
Extr CP Sag
Max Grad
Min Grad
Def CP Hog
Def CP Sag
Min C've len
Def len (HOG)
Def len (SAG)
K values (T)
Crest criterion (T)
Design speed
Reset params to default

**Curve insertion method:** There are two ways of implementing the IP method:

3 IPs: You give the data for a pair of adjacent grades, and then you give data for the curve opposite their intersection point; and so on in this fashion throughout the alignment.

All IPs: You give data for as many grades as are required; you then define the curves between the grades in any convenient sequence.

As with the element method **Curve parameter** (CP) can be toggled between *M-value* and *Vertex radius* and this will cause the default and check values to change to reflect that M is inversely proportional to R.

**Extreme CP hog and extreme CP sag:** The extreme values of hog and sag curve parameters are used throughout vertical ALIGNMENT as values against which calculated curve parameters are checked to ensure they are within an allowable range.

The default for extreme CP is zero. This is a special case which causes the system to not carry out the range checking on curve parameters.

**Max gradient and min gradient:** The gradient limits are used throughout vertical ALIGNMENT as values against which gradients are checked to ensure they are within an allowable range.

The **default hog** and **sag** curve parameters are used in the intersection point method for vertical alignments and can be used to define curve parameters which can be accessed as defaults for every curve on the alignment.

**K value:** Select the design standard to which you wish to work either UK (KmPH) or AASHTO (MPH).

**Design speed:** Type the design speed in KmPH (UK) or MPH (AASHTO) in the ranges 40 to 120. The program will adopt this speed or if you specify a value in the middle of the speed range then the nearest lower standard speed will be used.

**Crest criterion:** toggle between Overtake, Desmin, or Absmin. Where Overtake is overtaking distance, Desmin is the minimum desirable sight distance and Absmin is the absolute minimum sight distance; and you selection is the criterion for designing crest curves. (Default = desirable minimum).

◇ *The program has built in K values extracted from the standards listed above. There is also the opportunity to define individual K values as each curve is designed. The K value units for the UK are metres and for AASHTO feet. These units will be converted using a conversion factor of 0.3048 metres = 1 foot if the Linear measure units are set contrary to the design standard (UK or AASHTO). Wherever a K value can be used its value is displayed.*

**Reset params to default** resets all the design parameters to the default values held in the parameter file, except for those which are designated as special toggles. See Chapter 2 for a description of the parameter file.

# Vertical spline method

## Introduction

The Spline Method is offered as an alternative to the Element and IP methods. It is based on the alignment being a continuously curving spline between a sequence of points.

The methods adopted in this part of ALIGNMENT are performed differently from those elsewhere. This is because a spline alignment has to be analysed in its entirety rather than being constructed from separate elements.

It is not possible to switch between the spline and the other methods. However, it is possible to create a master string by combining a spline vertical alignment and an element (or IP) horizontal alignment (and vice versa).

Some theory related to vertical splines can be found in Chapter 7 (VCUSP).

## Spline alignment

IGIADS.DAT, IAD223

Spline alignment
Locate point
Respecify point
Delete point
Analyse
End this alignment

**Locate point** allows you to specify control points for the cubic spline being formed, or add a new point to an existing spline.

**Respecify point** allows you to change an existing point's location and associated parameters.

**Delete point** allows you to delete an existing point.

Analyse performs the cubic spline calculation.

## Locate point

IGIADS.DAT, IAD223,IAD224

Spline alignment	Locate point
Locate point	Point Ch
Respecify point	Lev
Delete point	Gradient
Analyse	Radius
End this alignment	Curve shape (T)
	Preceding point
	Following point
	No more points

**Point Ch, Lev** is used to define the chainage and level at control points which define the path of a cubic spline. By default, when you specify the location of a point, a locator symbol is drawn on the screen and Point Ch, Lev is automatically highlighted ready for locating the next point.

You may specify the **gradient**, the **radius** and the **curve shape** for the next point to be located. By specifying these values, you affect the way the spline will be drawn when it is analysed.

- ◇ *The gradient and radius are 'free' if no values are specified, except for the first and last points where the gradient is set to 0.*

If you enter a value for gradient or radius, or toggle the curve shape, you must then select 'Point Ch, Lev' from the menu in order to locate the point.

**Preceding point** and **following point** are used if you wish to locate a point out of sequence. For example, if you have entered three points and then wish to place an additional point between the first and second points, select 'Preceding point', then select the first point and finally enter the location of the new point.

- ◇ *Points can be added to previously analysed and non-analysed curves. In either case, you should re-analyse the points to produce the new curve.*
- ◇ *To amend an existing point, use 'Respecify point'*

When you have located all the points, select **no more points** which will return you to the 'Spline alignment' menu.

If you wish to produce the curve, select **Analyse**.



## Respecify point

IGIADS.DAT, IAD223,IAD225

Spline alignment	Respecify point
Locate point	Point
Respecify point	Relocation Ch Lev
Delete point	Gradient
Analyse	Gradient fixity (T)
End this alignment	Radius
	Radius fixity (T)
	Hand of arc (T)

To respecify a point, select the point, change any of its associated values and then Proceed. When you have finished respecifying points on a curve, re-analyse the curve using 'Analyse' on the 'Spline alignment' menu.

**Point** displays the point you have selected.

**Relocation Ch, Lev** allows you to relocate the point.

**Gradient** allows you to change the gradient at the point.

**Gradient fixity** allows you to free the gradient at a point where the gradient has previously been fixed.

**Radius** allows you to change the radius at a point.

◇ *To enforce a straight through a point, specify a radius of 0.*

**Radius fixity** allows you to free the radius at a point where the radius has previously been fixed.

**Hand of arc** can be toggled at a point where a radius has been fixed.

## Delete point

IGIADS.DAT, IAD223,IAD226

Spline alignment	Delete point
Locate point	Point
Respecify point	
Delete point	
Analyse	
End this alignment	

To delete a point, select the point then Proceed. When you have finished deleting points on a curve, re-analyse the curve using 'Analyse' on the 'Spline alignment' menu.

## Display parameters

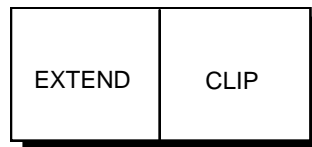
See the corresponding section in 'Horizontal spline method'.

## Selection methods (Alignment)

This section covers the following topics:

- Extend / Clip
- Hit codes
- ALIGNMENT point selection methods (PSMs)
- ALIGNMENT data amendment methods (DAMs)
- Conventions.

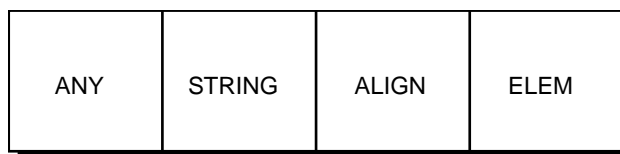
### Extend / Clip



The Extend/Clip boxes may be selected at any time whilst in alignment design and allow you to extend or clip elements.

For example, an arc will be extended to a full circle, and a straight element will be extended to the limits of the drawing window. Conversely, a circle will be clipped back to the arc from which it was generated.

### Hit Codes



Hit codes allow you to determine which type of feature is to be selected during the course of PSMs or SAME function, by making unrequired features unselectable:

When ALIGN is highlighted, elements are unselectable

When ELEM is highlighted, alignments are unselectable

When STRING is highlighted, both elements and alignments are unselectable

When ANY is highlighted, all features are selectable.

## ALIGNMENT point selection methods (PSMs)

### For horizontal design

The point selection methods described in this section are specific to horizontal alignment design, though they are similar to those described in Chapter 2.

There are eight methods available:

POINT	XY	INTS	CONSTR
IP	CHAIN	NORM	ORIG

In all cases the coordinates of the point will be displayed. The hit code may be changed to determine what sort of feature is selected.

#### POINT

This is a method for finding an exact point on an existing feature, either an alignment or a MOSS string.

If an alignment is selected the nearest point to the link of the selected alignment will be displayed.

If a MOSS string is selected a second selection is required to locate the appropriate point. At any time Keyboard may be selected to type in the appropriate name or point number.

Elements are invalid in POINT PSM unless using the SAMG/SAMB function.

#### XY

The actual coordinate position of the cursor, independent of the feature, is selected and displayed. If you select Keyboard, type in the coordinates.

#### INTS

The point selected and displayed is the intersection of two features which may be MOSS strings, alignments or elements (that is to say, the intersection may be found between an alignment and a MOSS string). For the three prompts you identify both strings and an approximate position for the intersection. If you select Keyboard you may type the response to any prompt.

#### CONSTR

CONSTRUCT is a method of obtaining a position or an angle from geometrically constructed elements, known as 'constructs'.

For further details, refer to Chapter 2, 'Point selection methods'.

#### IP

This PSM is invoked automatically when you pick an intersection element.

CHAIN

To use this PSM you must be referring to 6D master strings; you will not be able to determine the chainage on an alignment or element. If you select Keyboard then type in the chainage. A typed chainage need not be an exact point whereas a point selected by cursor will return information for an exact point.

The following text (NORM) is a copy from Chapter 2 page 32-33

NORM

With this PSM, there are three possibilities:

Case 1 finds the point on a string whose normal passes through the cursor position:

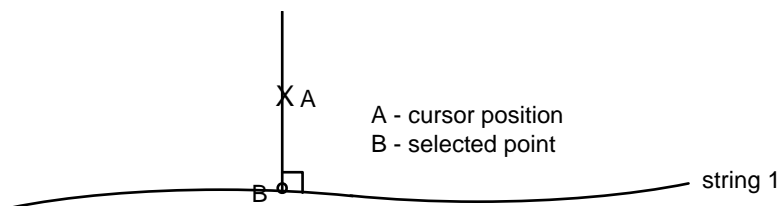


Figure 6 - 34 Example NORM Case 1

Case 2 finds the intersection point on a string intersected by a normal from another passing through an X/Y point in space.

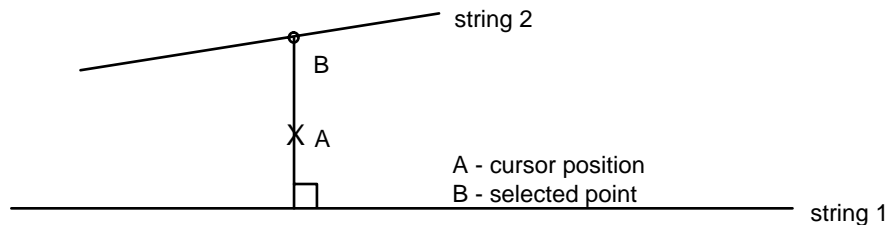


Figure 6 - 35 Example NORM Case 2

Case 3 finds the point on a string intersected by a normal constructed from a point on an alternative string.

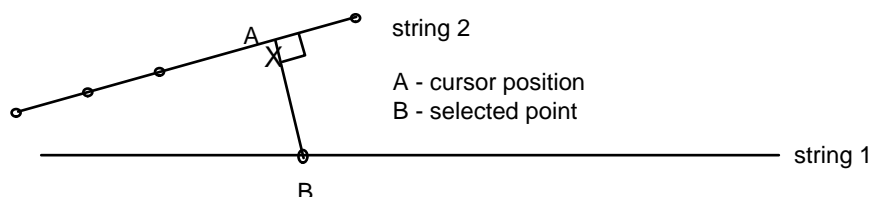


Figure 6 - 36 Example NORM Case 3

All cases have the same prompts:

P1 the string on which the point is found

For case 1 select string 1

For case 2 select string 2

For case 3 select string 1

P2 the string onto which a normal is to be dropped. This is string 1 for cases 1 & 2, but string 2 for case 3.

P3 the cursor position of A.

For identifying the cursor position (point A), all PSMs are valid.

Consequently point A could be the intersection of two strings (that is, in cases 1 and 2, A could be selected using X/Y PSM, whereas in case 3, A could be selected using POINT PSM.)

As for other PSMs if the string is already highlighted the first prompt is ignored.

If NORM PSM calculates more than one normal then the point closest to the cursor position will be displayed. The alternative normals are accommodated by employing the NEXT NORM feature in POINT AMEND. This is described in the next section.

## ORIG

This allows the user to select the origin of an alignment feature, either an element or an alignment.

The origins are defined as the 'start point' of transitions or straights, and the 'circle centre' for circular features.

## For vertical design

There are four methods:

POINT	XZ	CHAIN	IP

In all cases the chainage and level (X/Z) of the determined point will be displayed in the SMA.

### POINT

This is a method for finding an exact point on an existing feature; either an alignment or a MOSS string.

If an alignment is selected the nearest point to the link of the selected alignment will be displayed.

If a MOSS string is selected a second selection is required to locate the appropriate point. At any time Keyboard may be selected to type in the appropriate name or point number.

Elements are invalid in POINT PSM unless using SAMG/SAMB function.

### XZ

The actual coordinate position of the cursor, independent of the string is selected and displayed.

### CHAIN

Only MOSS strings and alignments are valid using CHAIN PSM. You will be prompted according to the type of feature selected:

P1 . Choose required Hit code, select drawing feature or choose new PSM. You may select an alignment or a MOSS string upon which to find the chainage.

If you select a MOSS string you get:

P2 . Select a position near the required point at which a locator pick can be used to locate the point, or Keyboard can be selected to type in a chainage.

If you select an alignment you get:

P2 . Type the required chainage

### IP

This PSM is invoked automatically when you need to pick an intersection between grades.

## ALIGNMENT data amendment methods

### For horizontal design

POINT AMEND	WCB AMEND	DIST AMEND	NEXT NORM
----------------	--------------	---------------	--------------

#### POINT AMEND

If you select POINT AMEND another menu is displayed:

N	S	E	W
F	B	L	R

N	North	
S	South	
E	East	
W	West	
F	Forward	Forward along the string
B	Back	Backwards along the string
L	Left	Left offset from the string
R	Right	Right offset from the string

The bottom four methods on the menu (Forward, Back, Left, Right) only apply to 6D strings and alignments.

For each choice you give the amount of movement in model units. N, S, E and W also refer to the model units, so you must be careful if the drawing displayed does not have North facing up the screen.

The details of the original point highlight will be displayed in the Status Area. As the point is moved around these details will change, and these will be shown in the scrolling menu area. (The status area always contains the original point).

When you are happy that the point highlighted is in the position you require you select PROCEED to accept the point and Exit from the Amend Option.

If you select QUIT at any stage of moving a point around, the point will be moved back to the last position.

The position of the point selected by the PSM may be amended at any time during its selection process.

#### WCB AMEND

This is used to amend the whole circle bearing from the value shown in the scrolling menu area to a new value. The selections are:-



+ang          -ang          +tan          -tan

The ang selections amend the bearing by the angle entered following the +/- ang. The angle is entered in the units selected for angular input style.

The tan selections amend the bearing by the conventional method of defining a taper (that is, the angle whose tangent is the reciprocal of the value given). So a taper of 1 in 12 would be entered as 12.

In either case the sign convention is that + adds the amendment in a clockwise direction and - anticlockwise.

Procedure is the same as for POINT AMEND.

## DIST AMEND

This is used to amend the value of any distance in the scrolling menu area. The menu selections are:

+                  -                  \*                  /

You add or subtract values to distances or to multiply or divide distances by a value.

Procedure is the same as for POINT AMEND.

## NEXT NORM

If the point was generated from NORM then NEXT NORM facility will be displayed and will give any alternative solutions.

## For vertical design

### POINT AMEND

+X	-X	+Z	-Z
F	B		

This feature allows you to modify a selected point by:

- +X                  increase in chainage dimension
- X                  decrease in chainage dimension
- +Z                  increase in level dimension
- Z                  decrease in level dimension
- F                    move forward along the feature by a given chainage
- B                    move backward along the feature by a given chainage.

**GRADIENT AMEND**

+GRAD	-GRAD	*	/
-------	-------	---	---

This allows you to modify a given gradient value by:

- +GRAD      increase value of gradient
  - GRAD      decrease value of gradient
  - \*
  - /
- multiply the gradient by a given value  
divide the gradient by a given value

# Railways

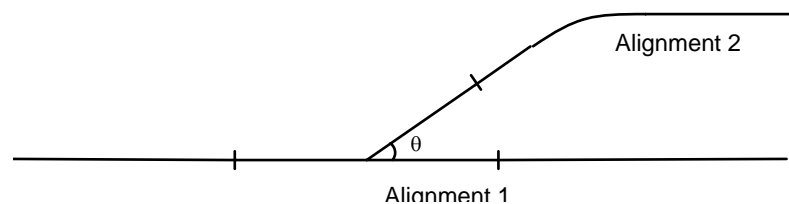
## Introduction

Major option ALIGNMENT has some special features for use specifically in railway design. These include alternative transition formulae and the ability to add turnout, symmetric and crossing components into an alignment.

A library of components is provided, which includes sections for components specified to differing national standards. The library may be used as supplied or customised to suit your own requirements. In addition, new components may be added to the library.

## Railway components

A railway component can be considered as a special alignment element which you may insert into an alignment (the main line). When you are satisfied with the configuration and position of the component, it is included in the alignment and new alignments are generated which incorporate the spurs from the component.



**Figure 6 - 37 Alignment generated from a railway component**

## Placing components

The placement of a component in an alignment has two main effects:

- The main line part of the component is overlaid on the alignment in which it is placed.
- One or more alignments are generated using a spur of the component as a single fixed element in the generated alignment.

Depending upon the type and orientation of a component, one part is treated as a straight or curved element for the first alignment while the remaining legs become fixed straight or curved elements in other alignments.

When a component is placed in the first alignment, the names of other alignments generated by the component must be specified.

A component must always be included as part of an alignment and will either overlay an element or be appended to one. If a component is

appended to an alignment, the main part of the component becomes an extra element which is added to the main alignment.

Once a component is placed in an alignment, it is possible to add further elements to the alignment and to edit it. However, if these operations lead to any part of a component no longer being on the alignment, then the operation is rejected.

If there is insufficient length of alignment in which to place a component, then, if possible, the alignment is lengthened to accommodate the component. Components may also require the alignment to be truncated to accommodate them in which case this is done automatically.

Figure 6 - 38 shows the effect of adding a component to the end of an alignment.

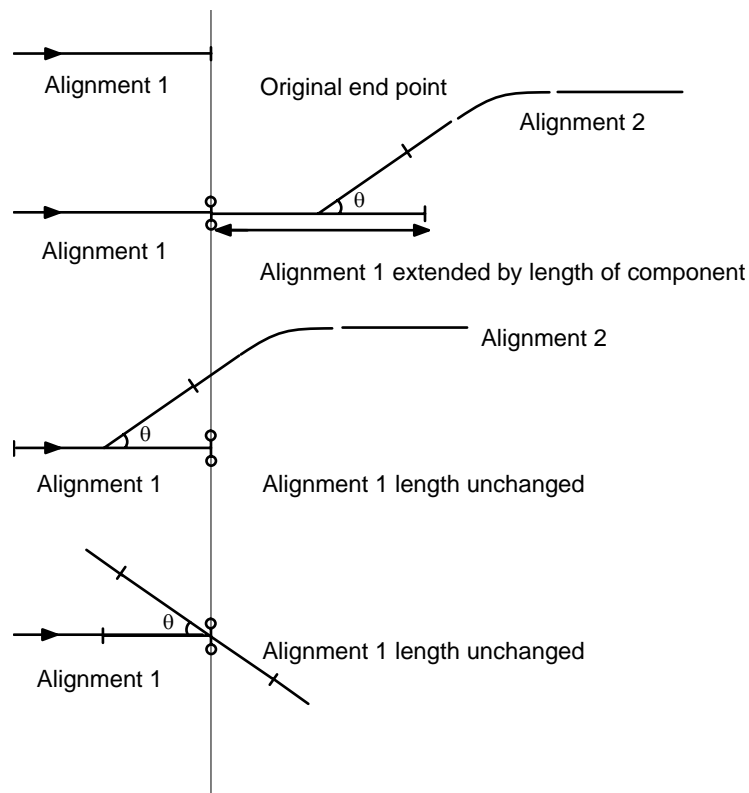


Figure 6 - 38 Railway component at end of alignment

## Vertical design with components

The vertical design for an alignment which contains components is carried out in a similar way to that for an alignment without components. However, an additional feature is available which relies on the principle that all alignments passing through a component must lie in the same plane. Once the level and gradient at the component have been determined, ie, when the main alignment has been designed vertically, these values may be used when designing the vertical profile for other alignments passing through the same component.

For schematic components, a single vertical grade element is used to represent a component already fixed in the main alignment on the vertical design profile of the newly generated alignment.

For true geometry components such as curved turnouts, this is not possible and so the following technique is adopted.

The cant on the main alignment is projected to determine levels on the generated turnout alignment. The generated alignment profile is then displayed in addition to the ground long section. Points can then be selected from the generated alignment profile to design the portion of the vertical alignment which lies within the component.

Refer to Figure 6 - 39 for further details.

- ◇ *Cant must be applied to the main alignment to enable levels to be determined for the generated alignment.*

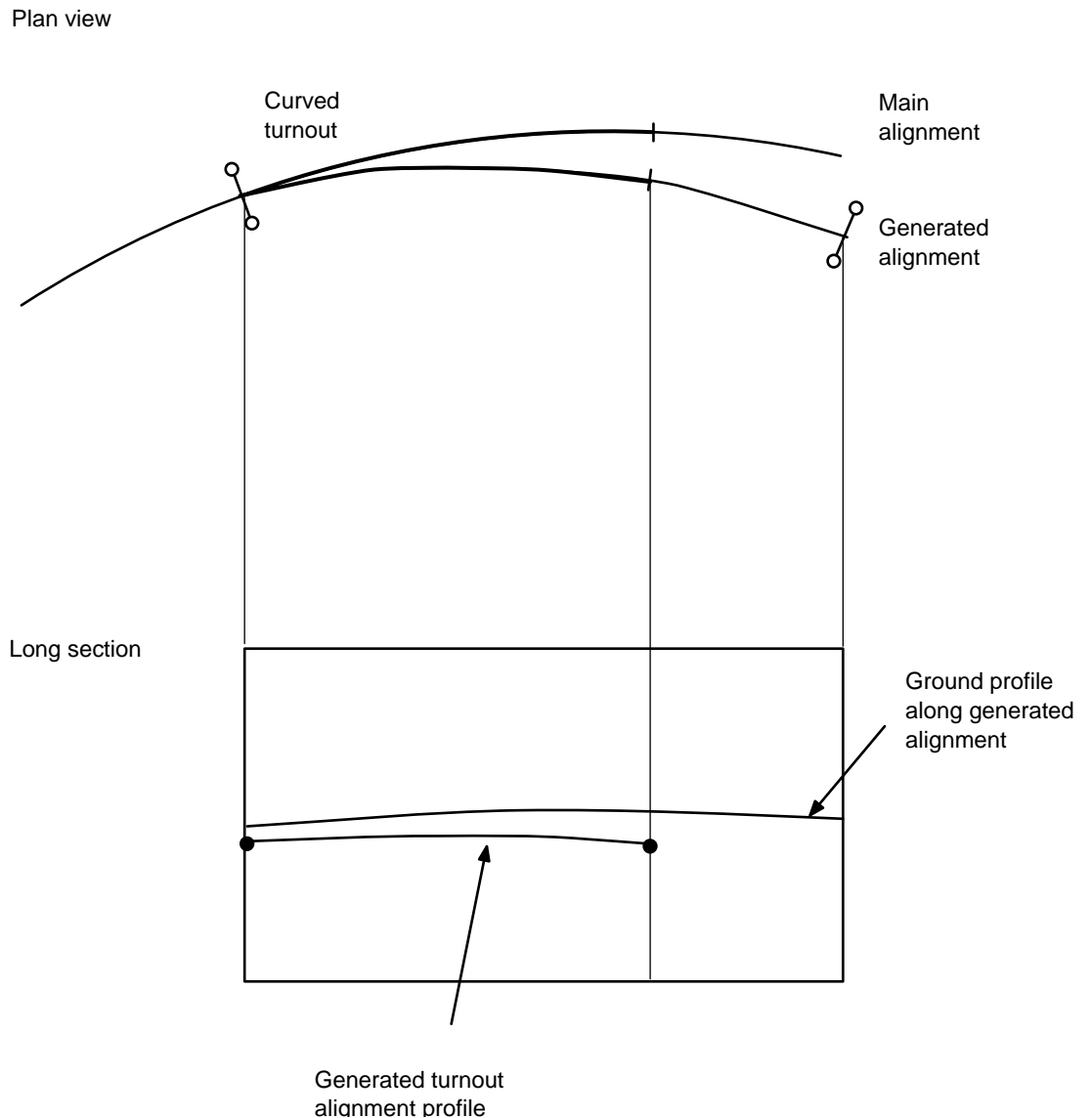


Figure 6 - 39 Vertical design with components

## Component library

The component library held in the railway switch file (RAITAB.DAT) defines the definition parameters for each available railway component. To define additional railway components, you must edit the file to include your own railway component information.

- ◇ *The name of the railway switch file is specified by the parameter file. The default name is 'raitab.dat'.*
- ◇ *The maximum number of components which may be stored in the component library is 200.*
- ◇ *The maximum number of component points per alignment is 1500. Typically, each component has 3 or 4 component points.*

## File format

The railway switch file is a fixed format ASCII file which is divided into sections:

Sections 100 to 199	General data
Sections 200 to 299	Standard components (not used)
Sections 300 to 399	Type 1 components
Sections 400 to 499	Type 2 components

Each record within a section has the following format:

### Columns 1 to 5

Record type:

xxxxyy where xxx is the section number  
yy is record number within the section.

### Column 6

Data type:

C	Character data
I	Integer data
R	Real data

### Column 7

A space character

### Columns 8 to 39

Component data.

Numerical data may be in integer or real notation and lie anywhere within the field.

Character data may contain embedded spaces.

### Column 40

A space character

### Columns 41 to 74

Record description. This field can contain any data as it is not used by the program.

## Example

```
10001C SW01
10002C UIC54 GEB PSK IB
10003I 2
10004R 140.000
10005I 1
10006I 2
30001R 34.700
30002R 99.340
30003R 36.949
30004R 62.391
30005R 2300.000
30006I 1
```

**Standard record types**

In the following tables:

- C            Character data
- I            Integer data
- R            Real data

**General data**

Record type	Data	Description
10001	C	Component reference (4 characters, unique, left justified)
10002	C	Component menu description (max 26 characters)
10003	I	Library 1 - Standard components (not used) 2 - Type 1 components 3 - Type 2 components
10004	R	Design speed
10005	I	Component type 1 - turnout 2 - crossing 3 - symmetric
10006	I	Availability 0 - straights only 1 - arcs only 2 - straights and arcs

**Type 1 components**

**Turnouts**

(see Figure 6 - 45)

Record type	Data	Description
30001	R	Tangent angle (1:n)
30002	R	Overall length L
30003	R	Dimension A
30004	R	Dimension B
30005	R	Nominal radius
30006	I	Turnout type 0 - standard 1 - curved

**Crossings**

(see Figure 6 - 46)

Record type	Data	Description
30001	R	Tangent angle
30002	R	Overall length L
30003	R	Dimension A
30004	R	Dimension B (same as A)



30005	R	Nominal radius
-------	---	----------------

**Symmetric**

(see Figure 6 - 47)

Record type	Data	Description
30001	R	Tangent angle
30002	R	Overall length L
30003	R	Dimension A
30004	R	Dimension B (not used)
30005	R	Nominal radius (not used)

Type 2 components

**Turnouts**

(see Figure 6 - 48)

Record type	Data	Description
40001	R	Tangent angle (grads)
40002	R	Dimension t
40003	R	Dimension b
40004	R	Nominal radius

- ◇ *Dutch components are defined as Type 1 components.*
- ◇ *Italian components are defined as Type 2 components.*

**Dutch clothoid length calculation**

Clothoid lengths may be calculated automatically to comply with Dutch national standards as a function of design speed, radius and other user defined parameters. These are:

- Deficiency factor
- Gradient type
- Minimum theoretical crossfall
- Maximum theoretical crossfall
- Maximum allowable crossfall

There are two cases in which automatic clothoid length calculation may be used:

**Fixed straight** connected to:

- Float arc: point and radius
- Free arc: given radius

**Fixed arc** connected to:

- Float arc: point and radius
- Free arc: given radius

Any free straight  
Any float straight

Once the speed and radius have been defined, the theoretical crossfall may be calculated according to the equation:

$$X_t = \frac{11.8v^2}{R}$$

where:

$X_t$  = theoretical crossfall

$v$  = design speed

$R$  = radius

If the calculated crossfall is less than the **minimum theoretical crossfall**, the element is fitted without a clothoid transition.

If the calculated crossfall is greater than the **maximum theoretical crossfall**, an increase in radius is required and the calculation is restarted.

If the calculated crossfall lies within the permitted range, it is rounded up to the nearest 5mm.

The user now has the option of subtracting a **deficiency factor**. Once this has been done, the result is compared with the **maximum allowable crossfall**.

If the calculated crossfall is greater than the maximum allowable crossfall, an increase in radius or another deficiency factor is required.

When the calculated crossfall is less than the maximum allowable crossfall, the gradient type is selected and the transition length calculated according to the following equation:

$$T_l = mvX_A$$

where:

$T_l$  = transition length

$m$  = gradient type factor

$v$  = design speed

$X_A$  = calculated crossfall

## Dutch transition calculation

If you are using Dutch transitions, an additional set of menus appears when you select Proceed from the following menus:

- Float straight: through point
- Float straight: given bearing
- Float arc: through point and radius
- Free straight
- Free arc: given radius

IGIADS.DAT, IAD265, IAD266

Dutch transitions 1	Dutch transitions 2
Pre element	Pre element
Fol element	Fol element
Pre radius	Pre radius
Fol radius	Fol radius
Pre hand	Pre hand
Fol hand	Fol hand
Transition	Transition
Design speed	Design speed
Theoretical crossfall	Theor. Xfall
Rounded theoret. crossfall	Rounded Xfall
Min theoretical crossfall	Deficiency factor
Max theoretical crossfall	Max Xfall
Condition	Calc Xfall
	Condition
	Default gradient type (T)
	Transition length

The purpose of the above menus is to calculate a transition length according to Dutch design criteria which are initially defined by the values in the 'Design parameters' menu.

If more than one transition length is required, such as at a reverse curve junction, the transition length calculation must be carried out the appropriate number of times.

The crossfall value and design speed used to calculate the transition lengths are stored on the geometry string associated with the alignment. This allows rail strings to be designed automatically using UPM.

- ◇ 'Preceding element' to 'Transition' are for information only
- ◇ Default values for Dutch design criteria are defined in the parameter file.

**Dutch transitions 1**

The first stage of the transition calculation produces a **rounded crossfall** value ( $X_r$ ) from the given radius and **design speed**.

- ◇ Initially, the design speed used is that specified in the 'Design parameters' menu, but you can override this value.

The rounded crossfall is then compared with the **theoretical crossfall**, the **minimum crossfall** and the **maximum crossfall** to produce a **condition** as follows:

**No transition:** Select Proceed to accept the condition and continue with the alignment.

**Transition required:** Select Proceed to perform the second stage of the calculation.

**Radius too small:** Enter a new design speed or select Quit to restart the calculation. If the current element is an arc, you are returned to the element definition menu so that you can respecify the radius. If the current element is a straight, you are returned to the 'next element' menu to respecify the straight completely.

Select Quit if you do not wish to accept the condition. You will then be returned to the menu indicated for the 'radius too small' condition.

Select Clear if you do not wish to accept the condition. You will then be returned to the 'next element' menu.

## Dutch transitions 2

The second stage of the calculation produces a transition length from the rounded **theoretical crossfall** calculated in the first stage.

A **deficiency factor** is subtracted from the theoretical crossfall giving the calculated crossfall. This is compared with the **maximum allowable crossfall** to produce a **condition**.

If the condition indicates that the calculated crossfall is too large, either modify the deficiency factor to recalculate it, select Quit to return to the first stage and change the design speed, or select Clear to return to the 'next element' menu.

◇ *'Design speed' is for information only in this menu*

Once the calculated crossfall is OK, the transition length is calculated using the gradient type displayed.

◇ *Initially, the gradient type used is that specified in the 'Design parameters' menu, but you can override this value.*

Select Proceed to continue the alignment with the transition length displayed.

◇ *You can override the calculated transition length by typing in a new value from the keyboard.*

## Report slope length

In order to obtain accurate measures of rail lengths for manufacturing purposes and to allow the design of fixed lengths of rail, report slope lengths works in the following way.

Access to slope length information is via the Status box in the static menu area when in Alignment, or using major option REPORT minor option 992 Report string details.

The slope length is calculated by summing the distances between successive string links. In Alignment this requires a temporary M-string to be created between the SPRD points from which the slope lengths are calculated. The slope length can be calculated in both horizontal and vertical alignment.

The formula used is:

$$\text{Slope length} = \sqrt{[(X_n - X_{n+1})^2 + Y_n - Y_{n+1})^2 + Z_n - Z_{n+1})^2]}$$

◇ *If a null level is encountered then the output will be terminated and an error given.*

◇ *If a discontinuity is encountered within the specified SPRD range then the output will continue, the message (DISCONTINUITY) will be added*

*against the point, slope and slope length calculated across the discontinuity.*

- ◇ *Strings where the third dimension is not a level, or where the slope between points exceeds 1:2 (50%) will report a warning.*
- ◇ *If you use REPORT 992 with field 2 coded as SLOP to report a geometry string; SLOP will be ignored.*

## Special geometry

Different types of railway component can be created or selected from a component library and positioned within a standard alignment element. Components are selected and positioned from the 'Specials' menu.

IGIADS.DAT, IAD034, IAD080

Next element	Special geometry
Fix straight	Single element alignment
Fix arc	Fix to fix
Float str	Select railway component
Float arc	Delete railway component
Free straight	Reload railway switch file
Free arc	Create three centre curve
Add straight	
Add arc	
Edit alignment	
Specials	

**Select railway component** is at the head of a family of menus which allow you to select and position a railway component. See 'Component definition' for further details.

**Delete railway component** allows you to delete a component from an alignment. You will be prompted to select the component to be deleted.

**Reload railway switch file** enables you to reload the railway switch file in to the current GDS. This is useful if you wish to amend the switch file and have the amended components accessible from an existing design.

## Component definition

The 'Component definition' menu is at the head of a family of menus which allow you to select and position a railway component according to the following procedure:

- Select the library and type of component to be used
- Select the element from the current alignment in which the component is to be inserted
- Choose the actual component to be inserted from a list in the scrolling menu area
- Insert the component into the alignment and configure the component so that it is correctly placed.
- Review the component and accept it if you are satisfied with its configuration. If you not, you may modify the configuration or abandon it completely.

IGIADST.DAT, IAD080, IAD303

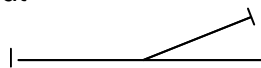
Special geometry	Component definition
Single element alignment	Component library
Fix to fix	Component type
Select railway component	Connecting element
Delete railway component	
Reload railway switch file	
Create three centre curve	
Report/modify flex element	

**Component library** is a toggle which allows you to select which set of components you wish to use in your alignment. Two libraries are available; Type 1 and Type 2.

- ◇ *The component libraries are stored in the railway switch file.*
- ◇ *The name of the railway switch file is specified in the parameter file. The default name is 'raitab.dat'.*

**Component type** is a toggle which selects which subset of the component library is to be made available. There are three component types:

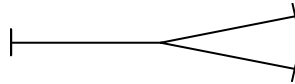
- Turnout



- Crossing



- Symmetric



**Connecting element** is the name of the element in which the component is to be inserted. The type of the element selected (ie, curve or straight) determines which components are made available in the next menu.

Select Proceed to display a list of suitable components.

◇ Components may be annotated using DRAW minor option 862.

## Suitable components

IGIADST.DAT, IAD080, IAD309

Suitable components

This menu lists all the available components of the type you selected from the chosen library.

Select the component you wish to place in the connecting element.

If a turnout from the Type 1 library is to be placed on a curve, the following menu is displayed:

IGIADST.DAT, IAD080, IAD307

Turnout usage on curve
Turnout usage (T)

**Turnout usage** is a toggle which allows you to specify whether a curved or a straight turnout is to be placed on the curve.



Figure 6 - 40 Curved turnout on curve

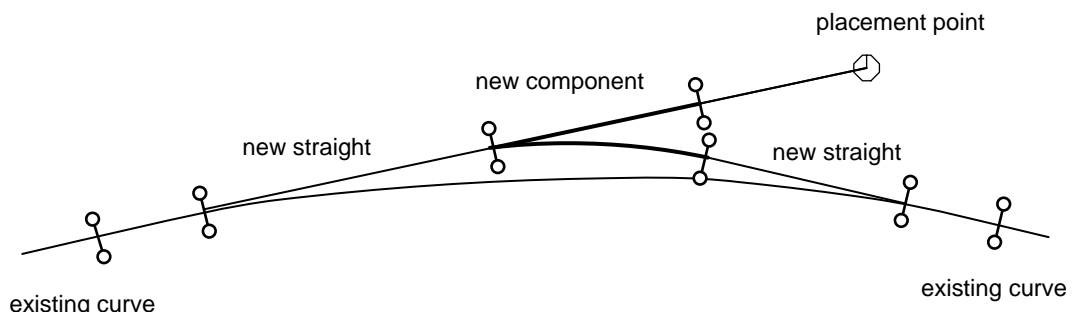


Figure 6 - 41 Straight turnout on curve

## Turnout configuration (curved)

Configures the selected curved turnout to the required orientation.



Turnout configuration
Description (R)
Turnout on (R)
Ref point X
Y
Generated alignment
Turnout geometry (T)
Turnout ref point (T)
Turnout spur to (T)
Turnout direction (T)
Turnout details

**Description** is the reference of the turnout to be inserted, as defined in the railway switch file (for information only).

**Turnout on** describes the element in which the turnout is to be placed, and may be either a right-hand curve, a left-hand curve or a straight (for information only).

**Reference point X,Y** defines the position at which the turnout is to be placed. You may select any point on the screen, including a tangent point on the alignment via Point PSM. If you do not place the turnout at a tangent point, a normal is dropped from the position you select on to the connecting element. The turnout is then placed so that the turnout reference point is positioned at the established point and the turnout is aligned in the direction of the connecting element.

**Generated alignment** is the label to be used for the new alignment generated by the addition of the turnout.

**Turnout geometry** is a toggle which determines whether turnouts are displayed in schematic form or in true geometry. In schematic form, the turnout is represented as straight lines. In true geometry, the actual curve of the turnout is shown.

**Turnout reference point** is a toggle which determines which part of the turnout is located at the reference point on the connecting element. The toggle takes the values 'leading', 'origin' or 'trailing'.

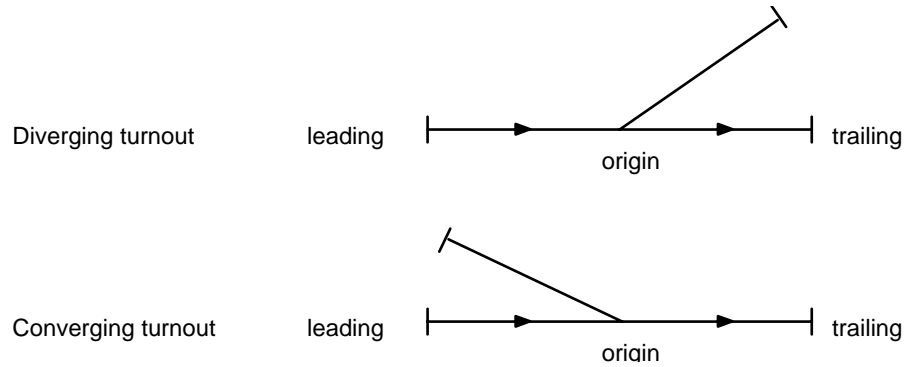


Figure 6 - 42 Turnout geometry

**Turnout spur to** controls whether the turnout spur is to the right or to the left when viewed in the direction of the connecting element.

**Turnout direction** is a toggle which controls whether the turnout is converging or diverging.

**Turnout details** displays details of the selected turnout in the scrolling menu area.

## Turnout configuration (straight)

Configures the selected standard turnout to the required orientation.

IGIADST.DAT, IAD080, IAD308

<b>Turnout configuration</b>
Description (R)
Turnout on (R)
Ref point X
Y
Generated alignment
Turnout direction (T)
Turnout details

**Description** is the reference of the turnout to be inserted, as defined in the railway switch file (for information only).

**Turnout on** describes the element in which the turnout is to be placed, and may be either a right-hand curve or a left-hand curve (for information only).

**Reference point X,Y** defines the position at which the turnout is to be placed. You may select any point on the screen using any PSM, although XY PSM is generally used. The turnout is then constructed as follows:

- A tangent is constructed from the connecting element to the point you selected.
- The turnout is placed onto the tangent so that the spur is also tangential to the connecting element.

See Figure 6 - 41 for a diagram of a straight turnout on a curve.

**Generated alignment** is the label to be used for the new alignment generated by the addition of the turnout.

**Turnout direction** is a toggle which controls whether the turnout is converging or diverging.

**Turnout details** displays details and dimensions of the selected turnout in the scrolling menu area.

## Crossing configuration

Configures the selected component to the required orientation.

IGIADST.DAT, IAD080, IAD305

Crossing configuration
Description (R)
Crossing on (R)
Ref point X
Y
Generated alignment
Crossing ref point (T)
Crossing hand (T)
Crossing details

**Description** is the reference of the crossing to be inserted, as defined in the railway switch file (for information only).

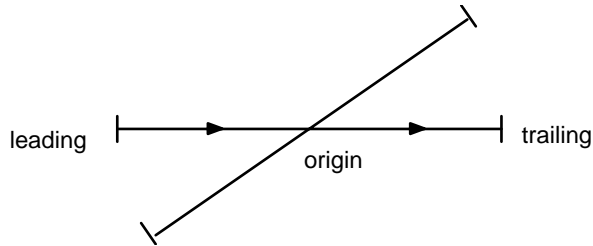
**Crossing on** describes the element in which the crossing is to be placed, and may only be a straight (for information only).

**Reference point X,Y** defines the position at which the crossing is to be placed. You may select any point on the screen, including a tangent point on the alignment via Point PSM. If you do not place the crossing at a tangent point, a normal is dropped from the position you select on to the connecting element. The crossing is then placed so that the crossing

reference point is positioned at the established point and the crossing is aligned in the direction of the connecting element.

**Generated alignment** is the label to be used for the new alignment generated by the addition of the crossing.

**Crossing reference point** is a toggle which determines which part of the crossing is located at the selected position on the screen.



**Figure 6 - 43 Crossing reference point**

**Crossing hand** is a toggle which controls whether the crossing is to the right or to the left when viewed in the direction of the connecting element.

**Crossing details** displays details and dimensions of the selected crossing in the scrolling menu area.

## Symmetric configuration

Configures the selected component to the required orientation.

IGIADST.DAT, IAD080, IAD306

Symmetric configuration
Description (R)
Symmetric on (R)
Ref point X
Y
Generated alignment 1
Generated alignment 2
Symmetric ref point (T)
Symmetric hand (T)
Symmetric direction (T)
Symmetric details

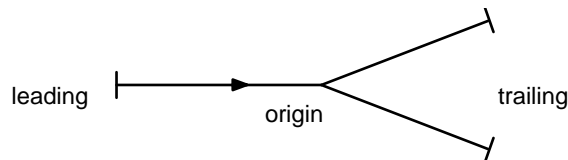
**Description** is the reference of the symmetric to be inserted, as defined in the railway switch file (for information only).

**Symmetric on** describes the element in which the symmetric is to be placed, and may only be a straight (for information only).

**Reference point X,Y** defines the position at which the symmetric is to be placed. You may select any point on the screen, including a tangent point on the alignment via Point PSM. If you do not place the symmetric at a tangent point, a normal is dropped from the position you select on to the connecting element. The symmetric is then placed so that the symmetric reference point is positioned at the established point and the symmetric is aligned in the direction of the connecting element.

**Generated alignments 1 and 2** are the labels to be used for the new alignments generated by the addition of the symmetric.

**Symmetric reference point** is a toggle which determines which part of the symmetric is located at the selected position on the screen.



**Figure 6 - 44 Symmetric reference point**

**Symmetric hand** has the effect of switching the new generated alignment labels from the left to the right. By default, the left hand spur is alignment 1.

**Symmetric direction** is a toggle which controls whether the symmetric is converging or diverging.

**Symmetric details** displays details of the selected symmetric in the scrolling menu area.

## Turnout details (type 1)

Displays details of the selected Type 1 turnout. All the details are provided for information only.

Turnout details	
Description	(R)
Turnout angle	(R)
Overall length	(R)
Dimension A	(R)
Dimension B	(R)
Nominal radius	(R)
Formula radius	(R)
Calculated radius	(R)
Speed	(R)

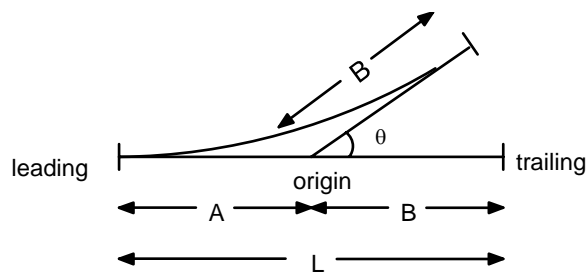
**Description** is the reference of the turnout to be inserted.

**Turnout angle** - see Figure 6 - 45.

**Overall length** - see Figure 6 - 45.

**Dimension A** - see Figure 6 - 45.

**Dimension B** - see Figure 6 - 45.



$\theta$  = turnout angle (1:n)

L = overall length

A = length from leading end to origin

B = length from origin to trailing end

**Figure 6 - 45 Type 1 turnout detail parameters**

**Nominal radius** is the radius of the turnout as defined in the railway switch file.

**Formula radius** is the estimated radius of the turnout spur based on the nominal radius and the radius of the connecting element.

**Calculated radius** is used to calculate the curve of the generated alignment, such that the curve is tangential to both the main alignment and a straight line drawn from the origin at the turnout angle. See Figure 6 - 45.

**Speed** is the design speed for the turnout.

## Crossing details

Displays details of the selected crossing. All the details are provided for information only.

IGIADS.DAT, IAD312

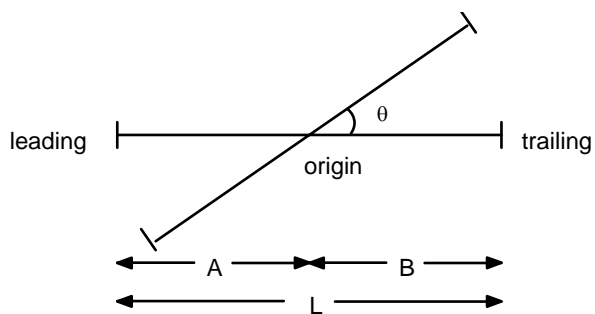
Crossing details	
Description	(R)
Angle	(R)
Overall length	(R)
Dimension A	(R)

**Description** is the reference of the crossing to be inserted.

**Angle** - see Figure 6 - 46

**Overall length** - see Figure 6 - 46.

**Dimension A** - see Figure 6 - 46.



- $\theta$  = crossing angle
- L = overall length
- A = length from leading end to origin
- B = length from oriain to trailina end (B = A)

**Figure 6 - 46 Crossing detail parameters**

## Symmetric details

Displays details of the selected symmetric. All the details are provided for information only.

IGIADS.DAT, IAD313

Symmetric details
Description (R)
Crossing angle (R)
Overall length (R)
Dimension A (R)
Dimension B (R)
Nominal radius (R)
Calculated radius (R)
Speed (R)

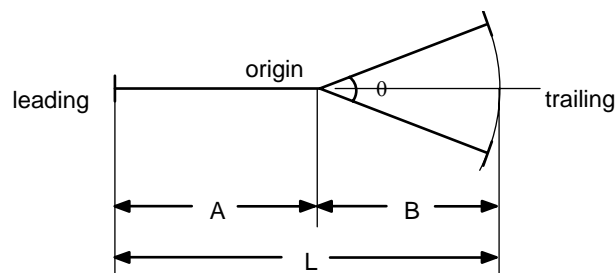
**Description** is the reference of the symmetric to be inserted.

**Crossing angle** - see Figure 6 - 47.

**Overall length** - see Figure 6 - 47.

**Dimension A** - see Figure 6 - 47.

**Dimension B** - see Figure 6 - 47.



$\theta$  = crossing angle

L = overall length

A = length from leading end to origin

B = length of spur (origin to trailing end)

**Figure 6 - 47 Symmetric detail parameters**

**Nominal radius** (not used).

**Calculated radius** (not used).



**Speed** is the design speed for the symmetric.

## Turnout details (type 2)

Displays details of the selected type 2 turnout. All the details are provided for information only.

IGIADS.DAT, IAD314

Turnout details	
Description	(R)
Turnout angle	(R)
Dimension t	(R)
Dimension b	(R)
Radius (Table)	(R)
Radius (Formula)	(R)
Radius (Calculated)	(R)
Speed	(R)

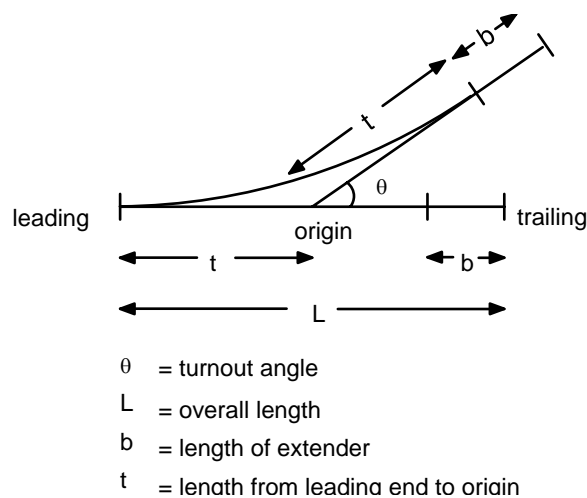
**Description** is the reference of the turnout to be inserted.

**Turnout angle** - see Figure 6 - 48.

**Overall length** - see Figure 6 - 48.

**Dimension t** - see Figure 6 - 48.

**Dimension b** - see Figure 6 - 48.



**Figure 6 - 48 Type 2 turnout detail parameters**

**Nominal radius** is the radius of the turnout as defined in the railway switch file.

**Formula radius** is the estimated radius of the turnout spur based on the nominal radius and the radius of the connecting element.

**Calculated radius** is used to calculate the curve of the generated alignment, such that the curve is tangential to both the main alignment and a straight line drawn from the origin at the turnout angle. See Figure 6 - 48.

**Speed** is the design speed for the turnout.

## Component review

IGIADS.DAT, IAD310

Component review
Accept component
Reconfigure component
Reselect component
Abandon

When the component is inserted in the alignment and configured correctly, the component review menu is displayed in the scrolling menu area.

**Accept component** - Select this field if you are satisfied with the component configuration. The component will then become part of the connecting element and all new alignments are generated.

**Reconfigure component** - Returns you to the appropriate component configuration menu.

**Reselect component** - Removes the component and allows you to select another component of the same type by returning you to the 'Suitable components' menu.

**Abandon** - Removes the component and returns you to the 'Component definition' menu.

# Associate alignments

Information missing.....coming soon...

## **Chapter 7 Non-interactive alignment**

### **Non-interactive alignment**

The MOSS design sequence, including the use of non-interactive alignment options, is shown in Figure 7 - 1.

Throughout this sequence, DRAW can be used to generate plans and sections or contour plans or perspective views via SURFACE and VIEW. The Interactive facilities simplify a great deal of the detail design and editing functions.

MOSS Design Sequence		
Models Required	Engineering Procedure	Major Options
Ground	- Preparation of ground model by aerial and/or ground survey.	DESIGN SURVEY GENIO
Geological	- If required prepare geological models from plans and borehole information for each significant strata.	IDIGIT EDIT
Road	- Selection and design of master alignments. (a) horizontal alignment design. (b) vertical alignment design.	HALGN HCUSP VERAT VALGN VCUSP
	- Determination of longitudinal ground profiles.	SECTION
	- Feature design, superelevation, channels, verges, etc	DESIGN EDIT
	- Investigation of drainage	TRIANGLE DRAINAGE
	- Extraction of ground cross sections if required for interface design	SECTION
	- Interface design - automatic or using extracted ground sections.	INTERFACE
	- Determination of topsoil strip and soiling areas.	AREA
	- Preliminary volumes, manually allowed for construction and topsoil	VOLUME
	- Extraction of model cross sections if required.	SECTION
	- Preparation of plotted plans and sections.	DRAW
	- Merging of road and ground models to produce an overall model of the new scheme.	COPY
	- Use of isopachytes for run-ins/resurfacing.	TRIANGLE
	- Calculation of setting out information.	SETOUT
Subsurface	- Creation of features defining the subgrade surface prior to construction and soiling.	DESIGN EDIT
	- Extraction of accurate earthwork volumes.	VOLUME
	- Preparation of mass haul analyses.	HAUL

**Figure 7 - 1 MOSS design sequence**

## Major option HCUSP

This major option permits the design of the horizontal alignments of highways consisting of a series of splined cubic curves. The technique is design orientated because the alignment passes through specified location points and can be visually defined on the road plan by the use of mechanical aids.

Spline curve fitting techniques have been developed to allow the superimposing of a continuous alignment through a series of specified location points and the resulting alignment is of polynomial form and wholly transitional.

The spline technique is to fit a separate curve between each successive pair of location points on the alignment in such a manner so as to allow continuity of bearing and curvature between adjacent curves. The minimum order of equation which permits such continuity is a cubic and this form of polynomial is used between the location points. The result is a smooth transitional alignment between desired end constraints and passing through all the location points.

A great advantage inherent in the technique is that the alignment can be visually presented by mechanical aids during the design evaluation and in fact this was the origin of the spline technique. Boxwood splines were used as a draughting aid to produce smooth curves through a series of fixed points. For alignment preparation either piano wire or coiled wire may be used and location 'bridges' permit the desired location. The wire produces a continuous curve of complex function but the section between each pair of location points is virtually a cubic and its approximation is used in the cubic spline evaluation of the alignment.

The advantages of immediately displaying an alignment are obvious particularly in restricted situations because the route of the alignment can always be mathematically defined. In unrestricted regions the location points will be nominal for fixing the alignment but where there are more constraints than can be satisfied, without introducing unsatisfactory reversal of curvature, the designer can utilise the mechanical spline to produce an optimum solution which can then be specified for final calculation.

The technique does not depend on a visual spline because by defining sufficient location points on a sketched route the program will produce a geometrically acceptable alignment. However, the visual aspect can introduce a new dimension into the design process that was not previously possible. It has been stated that between each pair of specified location points the cubic curve and wire curve are approximately the same and it is recommended practice that to ensure this approximation remains acceptable, the location points should be specified at least every 0.3m (12 inches) along the line and a point for every 1/8 point of a circle that the route turns through (ie a semicircle requires a minimum of five location points).

## Description and brief theory

### Spline alignments

To produce a wholly transitional alignment the program requires as input data the existing easting and northing coordinates of the location points defining the path of the desired alignment plus the initial bearings.

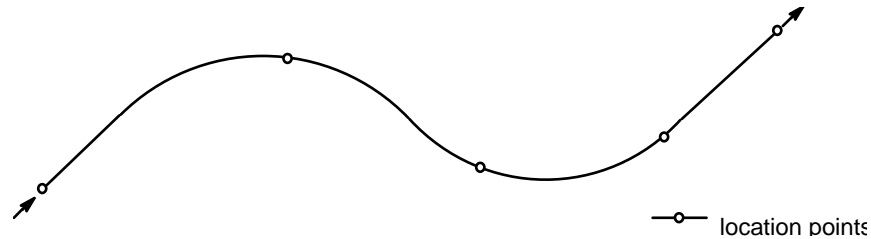


Figure 7 - 2 Simple spline

The form of cubic equation used to define the curves is not the simple form of:-

$$y = ax^3 + bx^2 + cx + d$$

which is used in the vertical alignment spline program because this only permits the alignment to proceed in one direction. To overcome this problem parametric cubic splines have been utilised and both the easting and northing coordinates of the alignment are expressed as a function of the curve length:

$$x = a + bt + ct^2 + dt^3$$

$$y = A + Bt + Ct^2 + Dt^3$$

where t is the distance (chainage) along the curve from some specified point.

For both the x and y coordinates a series of equations is formulated for each of the location points to define the continuity constraints of bearing and curvature between the adjacent parametric cubic curves. These are the spline conditions and the equations are solved by a cubic spline interpolation method (1) to give the end constraints for each parametric cubic curve from which the respective sets of coefficients a, b, c, d, and A, B, C, D are determined. Both the x and y coordinates have now been defined as a continuous function of the parameter t and thus x is a continuous function of y and vice versa.

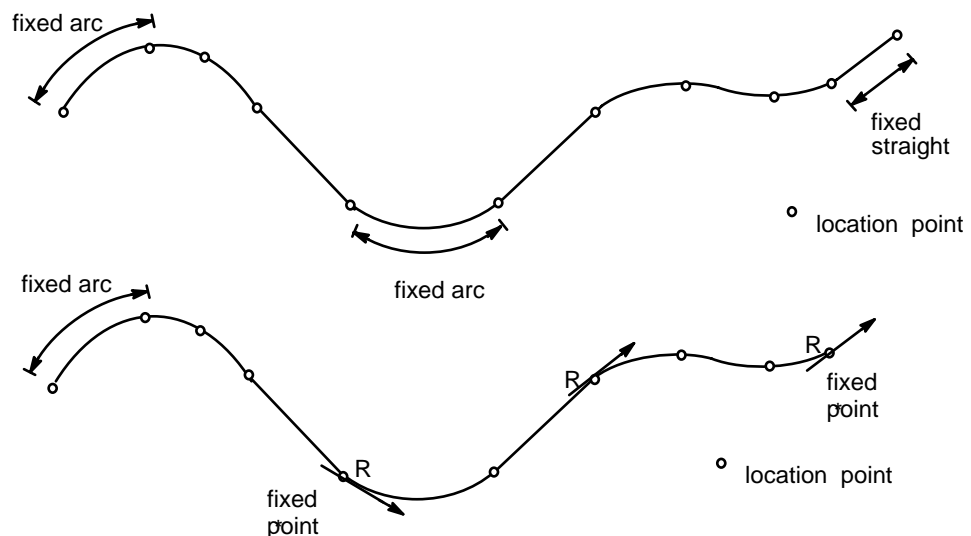
Initially the value of t which is the measure of length around the curve is estimated by taking the straight line distance between adjacent points. When the actual curve coefficients are determined the curve lengths are calculated by Romberg integration (2) and the previous estimate of length is checked within a specified tolerance. If this is unacceptable the new lengths are accepted as estimates of parameter t and a further iteration carried out.

Once this process is considered satisfactory the program proceeds to calculate the alignment details at the specified chainage interval. An additional feature of the program is that between each chainage interval additional coordinate points are included in the string as stored so that the lines joining the coordinate points are within a defined tolerance of the actual curve.

**Inclusion of straight and circular elements and fixed points**

The basic spline alignment only allows the bearings to be defined at the ends of the alignment. The radius determined at these points is dependent on the relative position of the adjacent location points. Although these points may be carefully selected it is very difficult to produce exactly the desired radius. This problem has been overcome by extending the technique to permit fixed straight or circular elements or points to be specified at the start and finish of the alignment and within the alignment. In these instances the problem resolves itself into a series of spline applications between each of the fixity conditions.

The inclusion of fixed elements and points introduces a further problem to the solution because the number of alignment constraints are greater than can be resolved by the cubic function as previously described. This curve requires the specification of the end coordinates and bearings of the element and the introduction of a radius requires special treatment. The technique adopted is to introduce an additional location point midway between the fixed element or point and the adjacent location point, which is free to move, until the required conditions are satisfied. This extra point is introduced into the parametric solution without specifying actual easting and northing coordinates and the equality of constraints is maintained.



**Figure 7 - 3 Spline and fixed elements**

The physical spline should always be used to ensure adequate location points are defined to produce both a desirable line and end continuity. The



adjustment technique ensures mathematically perfect merging of the spline and fixed elements or points.

Application of fixed elements and fixed end points

The introduction of fixed elements is intended to introduce greater flexibility to the spline alignment technique. It is not intended that the program should be able to simulate a conventional alignment of circular arc and straights. This is performed adequately by major option HALGN and options HCUSP and HALGN should be regarded as complimentary.

The fixed elements are specified in the following manner:

- STRAIGHT            A value of 999999.9 is specified for the radius at both the end location points.
- CIRCULAR ARC      The radius is specified at both the end location points. If the angle consumed by the arc is greater than 180 degrees/200 grads. a negative number is specified in the bearing field. (ie - 1).

The fixed points are specified following manner:

- STRAIGHT            The required bearing and a radius of 999999.9 is specified.
- CIRCULAR ARC      The required bearing and a radius is specified.

If the radius is omitted at an end fixed point then it is considered as a simple spline. This facility is not permitted at an intermediate fixed point.

The fixed elements are used as follows:

(i) fixed element - spline or splines - fixed element.

The element is specified as previously described and an additional location point is inserted on the first specified spline curve as shown.

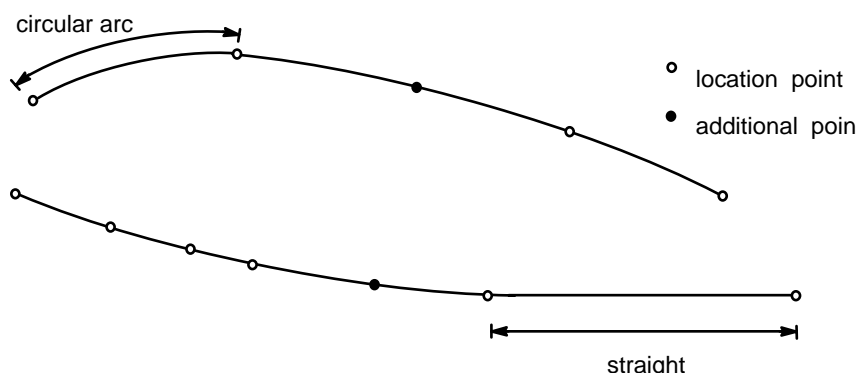
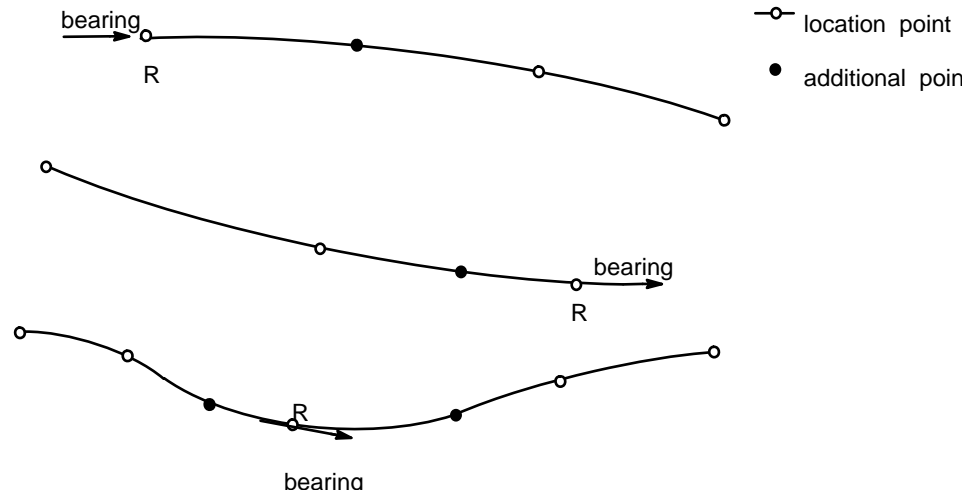


Figure 7 - 4 Use of fixed elements

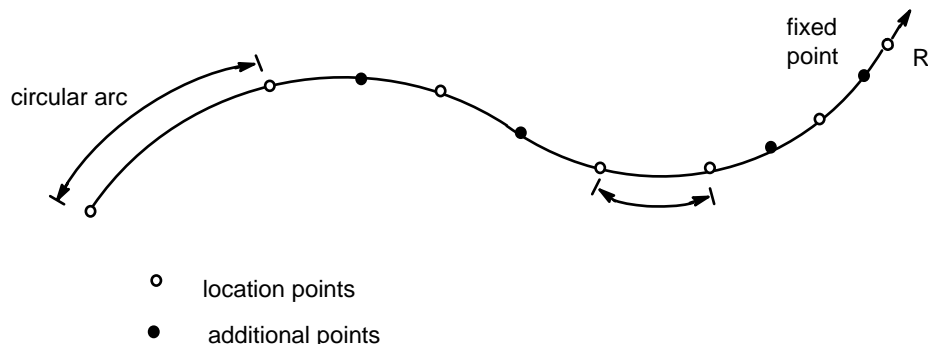
(ii) fixed point - spline or splines - fixed point.

This is a special case of the former type and can apply at the start and finish or at any intermediate point within the alignment.



**Figure 7 - 5 Fixed point - special case**

Fixed elements and points may be specified anywhere within the alignment as long as the intermediate splines consist of at least three specified location points, ie fixed elements and /or fixed points may not be adjacent.



**Figure 7 - 6 Fixed points - limitations**

**Practical considerations**

It cannot be emphasised too strongly that the physical spline is essential to ensure a satisfactory solution and to a greater extent when fixed points and elements are included. When spline alignments have been selected for a design the number of fixed elements or points should be a minimum to enable the natural property of the physical spline to produce the smoothest alignment.

The spline technique will always produce a satisfactory alignment and the advantages of introducing fixed straights and curves are simply for reproducing end conditions. In the case of intermediate elements, straights can simplify structural design and circular arcs may be advantageous where the alignment is at minimum radius. Intermediate fixed points are effectively elements of zero length and break the continuity of the natural spline.

### Chord-to-arc tolerance

The MOSS system stores information as strings of points and because a straight line is assumed between successive points it is necessary to generate sufficient points on master alignment strings to ensure that the accuracy of the straight line representation in the horizontal plane is within a limit specified by the user. The tolerance used to govern the number of points required is the maximum chord to arc distance.

The horizontal alignment options create points at the specified chainage interval but also check the chord to arc distance against the specified tolerance (default 0.1). The default chord-to-arc tolerance is determined by the variable AHDETOLR in the parameter file. If the tolerance is exceeded further points are introduced until the tolerance is satisfied.

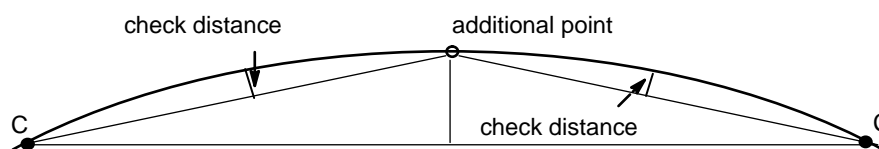


Figure 7 - 7 Chord-to-arc tolerance

These additional points do not appear on the printed output from the horizontal alignment options but are stored in the string.

Because the vertical radii tend to be large it is not normally necessary to generate additional points to satisfy a tolerance in the vertical plane. If, however, the vertical tolerance is in doubt the horizontal alignment must be run at an appropriate interval or the horizontal tolerance reduced.

## Data preparation

A standard input data sheet is provided for this option.

Major option HCUSP

Model 1 Model to contain the master alignment, if omitted the alignment will be calculated but not stored. This facility is useful while testing an alignment.

### Initial data

- \* Field 1 String label. This must start with M but must not be either MOSS or MACR.
- Field 2 Start chainage.
- Field 3 End chainage. If omitted the option will stop at the last location point.
- \* Field 4 Chainage interval.
- Field 5 Chainage of first point on alignment.
- Field 6 Tolerance used to determine frequency of points in the string.
- Field 7 Design speed.
- Field 8 Minimum radius.

- \* Field 9      Number of location points to follow (maximum 500 which includes any inserted by the program).
- Field 10      Number of special chainages (maximum 32).

**Location point details**

- Field 1      Easting.
- Field 2      Northing.
- Field 3      Bearing at location point if required (sexagesimal).
- Field 4      Radius at location point, +ve right hand, -ve left hand.  
If omitted at either the start or end point the simple spline solution is calculated.
- Field 5      Chainage interval for following element (optional).

**Special chainages record**

- Field 1 - 8    Special chainages where coordinates are required.

There are as many records as are necessary to accommodate the number of special chainages defined on the initial data record. A maximum of 32 special chainages is allowed.

**Final record**

The data should be terminated by a 999 minor option.

**Output data**

The printout details the element number, chainage, easting, nothing, bearing, radius and the rate of change of lateral acceleration on the requested chainage intervals, special chainages and location points. The resultant string contains data at these chainages and additional chainages so that the lines joining the coordinate points are within a defined tolerance of the actual curve.

**Interpretation of results**

The radius of curvature is determined at each of the chainage points and must be checked for compliance with the design standards. If the radius is less than that defined as the maximum on the initial data card a message is printed out at the relevant chainage. The points of contraflexure are indicated by the sign of the radius changing. The engineer must decide if the frequency of these points of contraflexure, and associated curvature, produce an acceptable horizontal alignment. If not, it may indicate a more refined choice of location points is necessary to produce a smoother alignment which may be verified by the use of design aids.

**References**

1. De Boor, Carl,  
"Bicubic Spline Interpolation", Journal of Mathematics and Physics, Vol. 41,  
1962 pp 212-218.
2. Fox, L and Mayers, D.F.,  
"Computer Methods for Scientists and Engineers", pp 176-181,

Clarendon  
Press, Oxford, 1968.

Example 1

Simple spline alignment

This is a simple spline alignment and is specified by four location points and the initial and final bearings. The alignment runs into straights at either end and only the physical spline and careful selection of location points has been used to produce a smooth run into the straights. (This could obviously improve by the use of fixed end points). The input data and printout are illustrated below.

MOSS

HCUSP,CUBIC SPLINE ALIGNMENT

MAST,158.6,2100.0,100.0,158.6,0.1,80.0,0.0,4,0  
34036.0,50633.0,782400.0  
34599.0,50670.0  
35322.0,50388.0  
35850.0,50468.0,731800.0  
999

```
HCUSP  CUBIC  SPLINE  ALIGNMENT
MAST158.6    2100.0    100.0    158.6    0.1    80.0    0.0    4    0
                                                W385 STRAIGHT LINE TOLERANCE EXCEEDS
                                                RECOMMENDED MAX.= 0.1 (0.5 IMP)

34036.0    50633.0    782400.0
34599.0    50670.0
35322.0    50388.0
35850.0    50468.0    731800.0
999
```

```
INITIAL DATA -----
LABEL = MAST
START CHAINAGE = 158.600
FINISH CHAINAGE = 2100.000
CHAINAGE OF FIRST POINT = 158.600
NORMAL CHAINAGE INTERVAL = 100.0
TOLERANCE = 0.100
DESIGN SPEED = 80.0
MINIMUM DESIGN RADIUS = 0.0
NO OF SPECIAL CHAINAGES = 0
NO OF GIVEN LOCATION POINTS = 4
NO OF CALCULATED LOCATION POINTS = 0
```

```
ALIGNMENT DETAILS -----
          CUBIC    CHAINAGE    C O O R D I N A T E S    BEARING    RADIUS OF RATE OF CHANGE
          ELEMENT    -----X-----    -----Y-----    DEG MIN SEC    CURVATURE LATERAL ACCEL.

LOCATION POINT    158.600    34036.000    50633.000    78 24 0.0    19316.4    -0.02431
1    200.000    34076.568    50641.256    78 37 49.2    7041.3    -0.02363
1    300.000    34174.808    50659.922    80 3 27.9    2803.8    -0.02389
1    400.000    34273.646    50675.061    82 44 29.6    1713.0    -0.02624
1    500.000    34373.190    50684.384    86 48 2.3    1192.7    -0.02972
1    600.000    34473.146    50685.312    92 24 26.9    890.8    -0.03219
1    700.000    34572.549    50675.035    99 40 21.4    709.5    -0.02949
LOCATION POINT    726.928    34599.000    50670.000    101 54 6.4    676.0    -0.02723
2    800.000    34669.629    50651.374    107 25 4.5    866.6    0.04914
2    900.000    34763.381    50616.687    112 46 42.2    1380.4    0.04454
2    1000.000    34854.383    50575.258    115 48 46.8    2922.0    0.03973
2    1100.000    34943.911    50530.711    116 45 30.8    -101812.7    0.03820
2    1200.000    35033.485    50486.256    115 41 30.7    -2729.2    0.04074
2    1300.000    35124.630    50445.147    112 28 57.4    -1310.7    0.04670
2    1400.000    35218.635    50411.162    106 50 8.1    -821.8    0.05219
2    1500.000    35316.026    50388.863    98 30 42.1    -595.1    0.04641
LOCATION POINT    1506.036    35322.000    50388.000    97 55 34.4    -586.3    0.04538
3    1600.000    35415.693    50382.030    89 41 11.7    -740.6    -0.04229
3    1700.000    35515.415    50388.690    83 1 16.7    -1016.1    -0.03735
3    1800.000    35614.019    50405.168    78 18 7.1    -1486.7    -0.03121
3    1900.000    35711.300    50428.279    75 13 19.7    -2448.4    -0.02727
3    2000.000    35807.559    50455.362    73 34 51.6    -6050.0    -0.02673
LOCATION POINT    2044.283    35850.000    50468.000    73 18 0.0    -18035.1    -0.02787

END OF ALIGNMENT -----
```

Example 2

Identical to example 1 but specifying end points as fixed end points. The input data and printout are illustrated below.

MOSS

HCUSP,CUBIC SPLINE ALIGNMENT

MAST,158.6,2100.0,50.0,158.6,0.1,80.0,,4,0

34036.0,50633.0,782400.0,999999.9

34599.0,50670.0

35322.0,50388.0

35850.0,50468.0,731800.0,999999.9

999

```

HCUSP  CUBIC SPLINE ALIGNMENT
MAST158.6    2100.0    50.0    158.6    0.1    80.0    4 0
$
W385 STRAIGHT LINE TOLERANCE EXCEEDS
RECOMMENDED MAX.= 0.1 (0.5 IMP)

34036.0  50633.0  782400.0  999999.9
34599.0  50670.0
35322.0  50388.0
35850.0  50468.0  731800.0  999999.9
999

```

INITIAL DATA -----

```

LABEL = MAST
START CHAINAGE = 158.600
FINISH CHAINAGE = 2100.000
CHAINAGE OF FIRST POINT = 158.600
NORMAL CHAINAGE INTERVAL = 50.0
TOLERANCE = 0.100
DESIGN SPEED = 80.0
MINIMUM DESIGN RADIUS = 0.0
NO OF SPECIAL CHAINAGES = 0
NO OF GIVEN LOCATION POINTS = 4
NO OF CALCULATED LOCATION POINTS = 2

```

ALIGNMENT DETAILS -----

	CUBIC ELEMENT	CHAINAGE	C O O R D I N A T E S		BEARING	RADIUS OF CURVATURE	RATE OF CHANGE LATERAL ACCEL.
			----X----	----Y----	DEG MIN SEC		
LOCATION POINT		158.600	34036.000	50633.000	78 24 0.0	INFINITY	0.00000
1		200.000	34076.561	50641.295	78 31 37.3	9336.5	-0.02840
1		250.000	34125.598	50651.056	79 1 9.4	4227.1	-0.02843
1		300.000	34174.748	50660.236	79 52 57.0	2731.8	-0.02839
1		350.000	34224.057	50668.515	81 6 58.1	2020.1	-0.02817
1		400.000	34273.555	50675.572	82 43 1.4	1607.3	-0.02757
ADDED LOCATION POINT		442.901	34316.180	50680.410	84 22 38.8	1373.3	-0.02658
2		450.000	34323.247	50681.087	84 40 35.8	1346.1	-0.02290
2		500.000	34373.109	50684.756	86 57 31.7	1173.8	-0.02503
2		550.000	34423.081	50686.296	89 34 4.4	1029.5	-0.02738
2		600.000	34473.067	50685.406	92 32 3.5	907.9	-0.02968
2		650.000	34522.927	50681.764	95 53 15.6	805.7	-0.03152
2		700.000	34572.464	50675.036	99 39 4.5	721.0	-0.03227
LOCATION POINT		727.012	34599.000	50670.000	101 51 33.0	682.1	-0.03196
3		750.000	34621.416	50664.905	103 43 50.1	727.4	0.04470
3		800.000	34669.565	50651.461	107 22 13.9	858.5	0.04690
3		850.000	34716.854	50635.237	110 24 4.2	1051.2	0.04651
3		900.000	34763.319	50616.780	112 49 34.1	1346.0	0.04482
3		950.000	34809.067	50596.609	114 39 59.0	1840.5	0.04280
3		1000.000	34854.250	50575.200	115 56 51.4	2837.6	0.04109
3		1050.000	34899.050	50552.997	116 41 30.1	5957.7	0.04005
3		1100.000	34943.661	50530.417	116 54 43.4	-72191.7	0.03986
3		1150.000	34988.288	50507.870	116 36 40.3	-5082.9	0.04057
3		1200.000	35033.135	50485.763	115 46 47.3	-2598.2	0.04215
3		1250.000	35078.400	50464.525	114 23 51.1	-1718.7	0.04440
3		1300.000	35124.262	50444.616	112 26 7.5	-1266.0	0.04692
3		1350.000	35170.874	50426.536	109 51 40.7	-991.3	0.04899
3		1400.000	35218.337	50410.830	106 38 57.9	-810.4	0.04945
3		1450.000	35266.674	50398.081	102 47 43.9	-687.5	0.04676
3		1500.000	35315.806	50388.875	98 20 10.8	-605.0	0.03946
LOCATION POINT		1506.255	35322.000	50388.000	97 44 23.8	-597.0	0.03817
4		1550.000	35365.519	50383.644	93 45 57.6	-668.0	-0.04368
4		1600.000	35415.486	50382.148	89 45 17.9	-765.7	-0.03997
4		1650.000	35465.447	50383.920	86 15 53.9	-882.0	-0.03557
4		1700.000	35515.229	50388.524	83 14 21.6	-1018.6	-0.03128
4		1750.000	35564.725	50395.570	80 37 21.1	-1179.2	-0.02752
ADDED LOCATION POINT		1775.106	35589.452	50399.917	79 26 49.4	-1270.7	-0.02590
5		1800.000	35613.880	50404.709	78 22 23.9	-1392.1	-0.03067
5		1850.000	35662.676	50415.606	76 31 6.5	-1737.1	-0.03184
5		1900.000	35711.139	50427.901	75 4 43.0	-2330.3	-0.03239
5		1950.000	35759.328	50441.234	74 3 40.3	-3558.6	-0.03259
5		2000.000	35807.325	50455.243	73 28 8.3	-7551.9	-0.03262
LOCATION POINT		2044.541	35850.000	50468.000	73 18 0.0	INFINITY	0.00000

END OF ALIGNMENT -----

Example 3

Complex spline alignment

This is an alignment illustrating the use of fixed elements and fixed points. There are twelve location points. Although the location points intermediate to the fixed curves are very carefully chosen, additional location points are used to ensure a perfect run-in.

The data input and printout are shown below together with a sketch of the alignment with the various constraints marked.

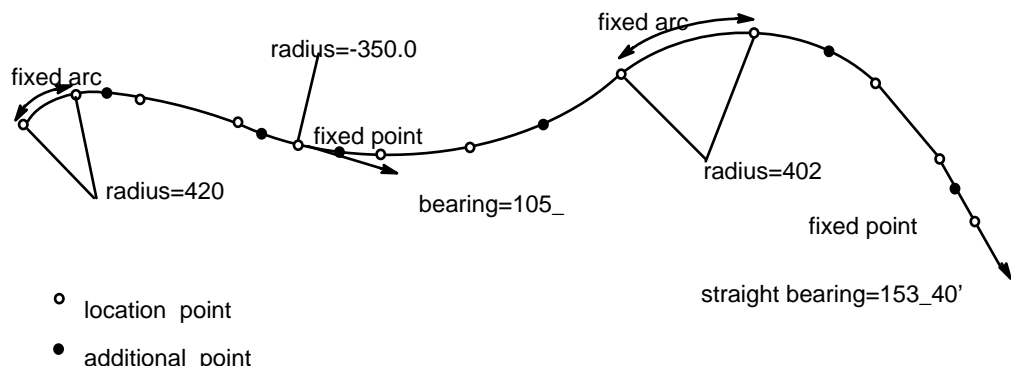


Figure 7 - 8 Spline fixed elements and fixed point

MOSS

HCUSP,CUBIC SPLINE ALIGNMENT

```

MAST,250.0,3100.0,50.0,178.0,0.1,80.0,250.0,12
498960.0,107600.0,,420.0
499180.0,107752.0,,420.0
499349.0,107764.0
499592.0,107698.8
499749.0,107630.0,1050000.0,-350.0
500020.5,107605.0
500303.5,107622.0
500685.0,107840.0,,402.0
500972.0,107896.0,,402.0
501225.0,107775.0
501394.0,107588.0
501496.0,107397.0,1534000.0,999999.9
999

```

```

HCUSP  CUBIC SPLINE ALIGNMENT
MAST250.0  3100.0  50.0  178.0  0.1  80.0  250.0  12
          $          W385 STRAIGHT LINE TOLERANCE EXCEEDS
          RECOMMENDED MAX.= 0.1 (0.5 IMP)

498960.0  107600.0  420.0
499180.0  107752.0  420.0
499349.0  107764.0
499592.0  107698.8
499749.0  107630.0  1050000.0  -350.0
500020.5  107605.0
500303.5  107622.0
500685.0  107840.0  402.0
500972.0  107896.0  402.0
501225.0  107775.0
501394.0  107588.0
501496.0  107397.0

```

501496.0 107397.0 1534000.0 999999.9  
999

INITIAL DATA -----

```

LABEL = MAST
START CHAINAGE = 250.000
FINISH CHAINAGE = 3100.000
CHAINAGE OF FIRST POINT = 178.000
NORMAL CHAINAGE INTERVAL = 50.0
TOLERANCE = 0.100
DESIGN SPEED = 80.0
MINIMUM DESIGN RADIUS = 250.0
NO OF SPECIAL CHAINAGES = 0
NO OF GIVEN LOCATION POINTS = 12
NO OF CALCULATED LOCATION POINTS = 6

```

ALIGNMENT DETAILS -----

CUBIC ELEMENT	CHAINAGE	C O O R D I N A T E S		BEARING DEG MIN SEC	RADIUS OF CURVATURE	RATE OF CHANGE LATERAL ACCEL.	
		-----X----	-----Y----				
1	250.000	499007.845	107653.686	46 37 7.9	420.0	0.00000	
1	300.000	499046.141	107685.786	53 26 23.2	420.0	0.00000	
1	350.000	499087.979	107713.112	60 15 38.6	420.0	0.00000	
1	400.000	499132.766	107735.275	67 4 53.9	420.0	0.00000	
1	450.000	499179.867	107751.962	73 54 9.2	420.0	0.00000	
1	450.138	499180.000	107752.000	73 55 17.0	420.0	0.00000	
LOCATION POINT	2	500.000	499228.633	81 0 31.4	386.1	-0.05164	
ADDED LOCATION POINT	3	535.359	499263.765	86 25 48.7	361.7	-0.05596	
3	550.000	499278.391	107767.368	88 37 50.1	403.1	0.21425	
3	600.000	499328.348	107765.869	94 20 45.6	659.5	0.20591	
LOCATION POINT	4	620.737	499349.000	107764.000	95 55 6.7	883.1	0.20062
4	650.000	499378.051	107760.496	97 50 54.1	854.6	-0.01486	
4	700.000	499427.350	107752.195	101 18 9.8	804.4	-0.01708	
4	750.000	499476.036	107740.846	104 58 46.8	754.6	-0.01890	
4	800.000	499523.862	107726.297	108 54 9.5	707.0	-0.02006	
4	850.000	499570.539	107708.405	113 5 10.9	663.8	-0.02022	
LOCATION POINT	5	873.513	499592.000	107698.800	115 8 42.1	645.4	-0.01984
5	900.000	499615.788	107687.153	116 47 46.1	1595.8	0.38159	
5	950.000	499660.390	107664.557	116 6 56.2	-912.2	0.37401	
ADDED LOCATION POINT	6	959.260	499668.727	107660.527	115 27 1.5	-708.8	0.37119
6	1000.000	499706.066	107644.253	111 23 28.2	-481.9	0.18542	
LOCATION POINT	7	1045.261	499749.000	107630.000	105 0 0.0	-350.0	0.18964
7	1050.000	499753.585	107628.804	104 14 15.6	-362.5	-0.22957	
7	1100.000	499802.676	107619.448	97 50 49.1	-586.1	-0.22636	
7	1150.000	499852.404	107614.321	94 24 9.9	-1412.1	-0.21374	
ADDED LOCATION POINT	8	1182.472	499884.799	107612.090	93 40 24.0	-13396.2	-0.21645
8	1200.000	499902.292	107610.980	93 34 44.2	-8816.8	0.02444	
8	1250.000	499952.206	107608.047	93 5 37.3	-4437.5	0.02444	
8	1300.000	500002.149	107605.676	92 17 28.2	-2996.4	0.02287	
LOCATION POINT	9	1318.363	500020.500	107605.000	91 55 12.6	-2693.7	0.02191
9	1350.000	500052.125	107604.141	91 9 43.9	-2150.0	0.03263	
9	1400.000	500102.122	107603.771	89 36 56.4	-1625.9	0.03327	
9	1450.000	500152.106	107604.938	87 38 4.2	-1300.7	0.03425	
9	1500.000	500202.007	107608.027	85 12 23.0	-1078.7	0.03515	
9	1550.000	500251.709	107613.425	82 19 12.3	-918.9	0.03543	
9	1600.000	500301.043	107621.517	78 58 22.0	-801.4	0.03438	
LOCATION POINT	10	1602.504	500303.500	107622.000	78 47 35.3	-796.4	0.03428
10	1650.000	500349.770	107632.684	75 6 50.4	-688.4	0.04851	
10	1700.000	500397.554	107647.362	70 37 22.3	-592.7	0.05415	
10	1750.000	500443.925	107666.016	65 25 41.0	-515.0	0.05686	
10	1800.000	500488.266	107689.074	59 29 52.1	-455.4	0.05341	
ADDED LOCATION POINT	11	1824.560	500509.074	107702.115	56 19 33.7	-432.8	0.04844
11	1850.000	500529.855	107716.784	53 22 38.1	-575.9	-0.24591	
11	1900.000	500568.935	107747.962	49 58 32.7	-1538.1	-0.23088	
11	1950.000	500606.979	107780.406	49 36 5.2	2593.2	-0.22670	
11	2000.000	500645.640	107812.106	52 12 10.8	695.2	-0.23661	
LOCATION POINT	12	2048.260	500685.000	107840.000	57 37 53.9	402.0	-0.23496
12	2050.000	500686.472	107840.928	57 52 46.6	402.0	0.00000	
12	2100.000	500730.360	107864.815	65 0 21.5	402.0	0.00000	
12	2150.000	500776.873	107883.072	72 7 56.3	402.0	0.00000	
12	2200.000	500825.292	107895.418	79 15 31.1	402.0	0.00000	
12	2250.000	500874.868	107901.661	86 23 5.9	402.0	0.00000	
12	2300.000	500924.836	107901.707	93 30 40.8	402.0	0.00000	
LOCATION POINT	13	2347.536	500972.000	107896.000	100 17 11.3	402.0	0.00000
13	2350.000	500974.423	107895.553	100 38 10.8	405.1	0.08419	
13	2400.000	501022.914	107883.473	107 9 26.6	479.5	0.08201	
13	2450.000	501069.890	107866.402	112 36 57.2	577.2	0.07238	
ADDED LOCATION POINT	14	2489.390	501105.734	107850.085	116 14 40.4	671.9	0.06371
14	2500.000	501115.213	107845.318	117 8 54.6	673.1	0.00312	
14	2550.000	501158.820	107820.879	121 22 45.4	681.9	0.00519	
14	2600.000	501200.520	107793.311	125 32 34.0	694.9	0.00682	
LOCATION POINT	15	2630.573	501225.000	107775.000	128 2 46.0	704.8	0.00758
15	2650.000	501240.133	107762.819	129 36 55.6	713.7	0.00971	
15	2700.000	501277.514	107729.628	133 34 11.4	734.8	0.00785	
15	2750.000	501312.551	107693.970	137 25 19.1	751.9	0.00577	
15	2800.000	501345.140	107656.061	141 11 56.2	764.2	0.00354	
15	2850.000	501375.178	107616.101	144 55 47.3	770.6	0.00121	
LOCATION POINT	16	2883.825	501394.000	107588.000	147 26 34.3	771.3	-0.00040
16	2900.000	501402.566	107574.280	148 34 47.1	864.5	0.09532	
2950.000	501427.542	107530.970	151 16 8.0	1387.9	0.09565		
ADDED LOCATION POINT	17	2992.136	501447.329	107493.770	152 33 57.8	2820.8	0.09504
17	3000.000	501450.943	107486.785	152 43 12.0	3041.1	0.03585	
17	3050.000	501473.554	107442.191	153 25 40.1	6051.6	0.03593	
17	3100.000	501495.797	107397.410	153 39 59.9	666809.9	0.03594	

END OF ALIGNMENT -----



## Major option HALGN

HALGN permits the design of the horizontal alignment of highways by the conventional approach of using straight and circular elements linked by transitions.

The desired alignment should be initially drawn on a plan with the aid of circular templates. The alignment is specified by a series of circular or straight elements of varying fixity which permit the designer varying degrees of freedom to locate the alignment.

The fixity of an element is measured by the extent to which the element is defined by the user and there are three classes of fixity:-

- FIXED        precisely located in position.
- FLOATING    defined by two constraints allowing one degree of freedom, such as rotation about a point.
- FREE         defined by one constraint allowing two degrees of freedom. The location is determined by the arrangement of the adjacent elements.

### Main features

The following list details the more generally used features of the option:

Input is completely FREE FORMAT

A maximum of 500 elements may be processed.

Element fixing takes place both forwards and backwards.

Single element alignments may be defined.

Transitions may be defined in a variety of ways.

Offset alignments may be used.

A local origin may be given to facilitate data input

Special chainages and special chainage intervals may be requested.

Transitions may be applied using French design rules based on road type and design speed.

### Alignment analysis

Circular Arcs and Straights are termed Elements to differentiate them from transition curves. The program analyses the elements in sequence and calculates the details of the required transition curves and their associated tangent points.

The program analyses the data progressively starting from the first fixed element. If the element to either side of this fixed element is floating then the necessary calculations are performed to fix it, bearing in mind that tangential continuity is required.

Should the adjacent element be a free element then another 'fixed' curve needs to exist before it can be resolved. Thus the curves need to be

specified by the user so that the overall information is sufficient to fix each element explicitly.

Leading or Trailing Transitions may be specified for each of the curved elements to ensure that both curvature and bearing are continuous throughout the alignment. The transition curves may be any of the following:

1. Clothoid transitions
2. Bloss transitions
3. Biquadratic parabola transitions
4. Cubic parabola transitions
5. Sine transitions.

Within the program the parameters of clothoid transitions may be derived from the following specified values:

1. transition length
2. standard speed / RL value / A value
3. special speed / RL value / A value
4. application of national design rules related specifically to road design or railway design

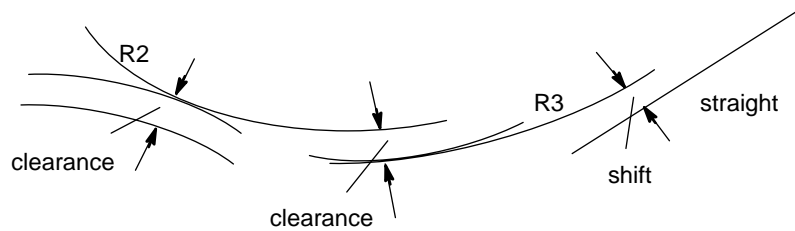
◇ *Standard speed is the overall speed specified for a complete alignment whereas special speeds may be specified for individual elements within an alignment.*

Within the program, the parameters of Bloss, Biquadratic, Cubic parabola and Sine transitions may be derived from the transition length only.

Offset alignment techniques are useful for designing slip roads and channels which bear a relationship to previously designed lines. Points on the alignment under design are specified by perpendicular offsets from a fixed primary element or transition.

### Design techniques

It is important to draw the alignment in plan with the use of circular templates allowing for sufficient clearances to accommodate transitions before running the option.



**Figure 7 - 9 Plan of alignment using circular templates**

It ought to be remembered that there are number of facilities within the option which, if not properly used, diminish the effectiveness of the process. Drawing a draft alignment helps to alleviate this danger.

**Element definition**

The option analyses the data progressively starting from the first fixed element. If the element to either side of this fixed element is floating then the necessary calculations are performed to fix it, bearing in mind that tangential continuity is required.

Should the adjacent element be a free element than another 'fixed' curve needs to exist before it can be resolved. Thus the curves need to be specified by the user so that the overall number of constraints is equal to the number of unknowns.

For example: The following arrangements of curves are permissible:-

```

FIX      :          FREE      :  FIX
FIX      :          FLOATING  :  FREE :  FIX
FIX      :          FLOATING  :  FREE :  FLOATING :  FIX
    
```

The following arrangements of curves are not permissible:-

```

FIX      :          FREE      :  FLOATING
FLOATING :          FREE      :  FIX
FREE     :          FIX       :  FIX
    
```

To make the last set of combinations feasible:-

```

FIX      :          FREE      :  FLOATING :  FIX
FIX      :          FLOATING  :  FREE   :  FIX
FIX      :          FREE     :  FIX    :  FIX
    
```

The option will resolve elements as follows:-

**Step 1**

Going forwards from the first element to the last, the option will:-

1. convert to FIX any floating element which follows a fixed element.
2. convert to FIX any free element which lies between two fixed elements.

### Step 2

If all elements are fixed by this stage the option proceeds to the final analysis. Otherwise the option works backwards from the last element to the first, and will:-

1. convert to FIX any floating element preceding a fixed element.
2. count any unfixed elements.

### Step 3

Should all the elements be fixed the option proceeds to the final analysis. If any element became fixed in Step 2 then Step 1 is reprocessed.

If no element became fixed in Step 2 yet all elements are not fixed then the alignment is underspecified.

The following notes need to be considered in specifying elements.

1. There must always be at least one fixed element in an alignment.
2. Neither the first nor the last element may be a free element.
3. Two adjacent elements can never both be free.
4. Between any two free elements there must be at least one fixed element.
5. If two adjacent elements are fixed the transitions between them may be accommodated by applying C, S, and Summit curve transition specifications. Adjacent curves of the same hand may be joined with a single partial transition.
6. When two curves of like hand occur together, they share the same transition, and therefore the RL Value must be the same for the common end of either curve. The option will check for this condition, and if different values have been given, it will adjust one of the transition lengths to conform to the lower RL Value.
7. Throughout the major option if Danish notation is currently in use the RL Value should be read as the A Value where  $A = \sqrt{RL}$ . This convention is interpreted by the program.

### Fixed elements

Each (and every) alignment must have at least one fixed element, be it a straight or a circular arc. There are eight alternative ways of defining a fixed element and these are detailed as follows:-

1. straight defined by two points.
2. straight defined by one point and the tangent bearing.
3. curve specified by three points.
4. curve specified by its centre and one point.
5. curve specified by its centre and radius.
6. curve specified by two points and radius.
7. curve specified by one point and one point plus tangent bearing.
8. curve specified by radius and one point plus tangent bearing.

If an alignment is a one element alignment then that element must be fixed and at least one point (defining the chainage datum) must be defined. Thus the element cannot in this situation be a circle defined by its centre and radius.

If there are two adjacent fixed elements each will be fixed independently of the other and an iterative method is employed to calculate the required lengths of transition between the two elements.

(Greater accuracy will be attained for fixed elements defined by two or more points, if those points are not close together).

### **Floating elements**

A floating element has one degree of freedom and becomes fixed by ensuring tangency conditions hold between it and an adjacent fixed element, (either before or after it), whilst accommodating the required transitions. Thus the option finds the first fixed element and then solves the floating elements either backwards or forwards.

There are four ways of defining a floating element and these are detailed as follows:-

- straight specified by one point.
- straight defined by the tangent bearing.
- curve specified by one point and radius.
- curve specified by one point and the tangent bearing.

The option does not cater for:-

- a floating curve specified by its centre.
- a floating curve specified by two points.

When floating an element about a defined point greater accuracy will be attained by situating the defined point at a maximum distance from the fixed element to which it will relate.

When pivoting an element about a defined point care should be taken to ensure the required curve does not consume more than 180 degrees of arc.

The specified transitions permit the calculation of the clearance between the floating element and the previously fixed element.

For those floating elements for which the option needs to calculate the radius the transitions may only be specified by defining the speed/RL Value.

### **Free elements**

A free element has two degrees of freedom and becomes fixed by ensuring tangency conditions hold between it and both adjacent elements, whilst accommodating the required transitions. Both adjacent elements must be fixed (either on input or during calculation) before the free curve can be resolved.

There are two ways of defining a free element namely:-

- a straight with no associated data.
- a curve specified by radius.

- ◇ *Since a straight is a curve of infinite radius both the above situations are the same.*
- ◇ *A free element cannot be defined by one point.*
- ◇ *Neither the first nor the last element may be free.*
- ◇ *Two adjacent elements cannot both be free.*
- ◇ *Between two free elements there must always be a fixed element.*

There are occasions when two solutions exist for the position of the free element. They occur when the free element is a curve and either of the two fixing elements is also a curve. The first and alternative solutions as chosen by the option are shown in the accompanying diagrams and the rule governing the choice is as follows:-

1. If all three elements are circular arcs, the alternative centres of the free curve are symmetrical about a line between the centres of the fixed circles, and the alternative solutions are selected as follows:-

Looking from the centre of the first circle to the centre of the third circles, the first solution is to position the centre of the free element on the right if it is a right hand element, and on the left if it is a left hand element. The alternative solution lies on the opposite side of the line to the first solution.

2. If one of the fixed elements is a straight, then the two alternative centres are symmetrical about the foot of the perpendicular from the centre of the fixed circle to the fixed straight. The first solution is found by placing the centre of the free element so that the length of the straight is smaller, the solution giving the longer straight being the second one.

Should the alternative solution be required then a simple modification to the data gives it.

In the following diagrams it will be noted that diagram 4 is a situation which will normally require the alternative solution.

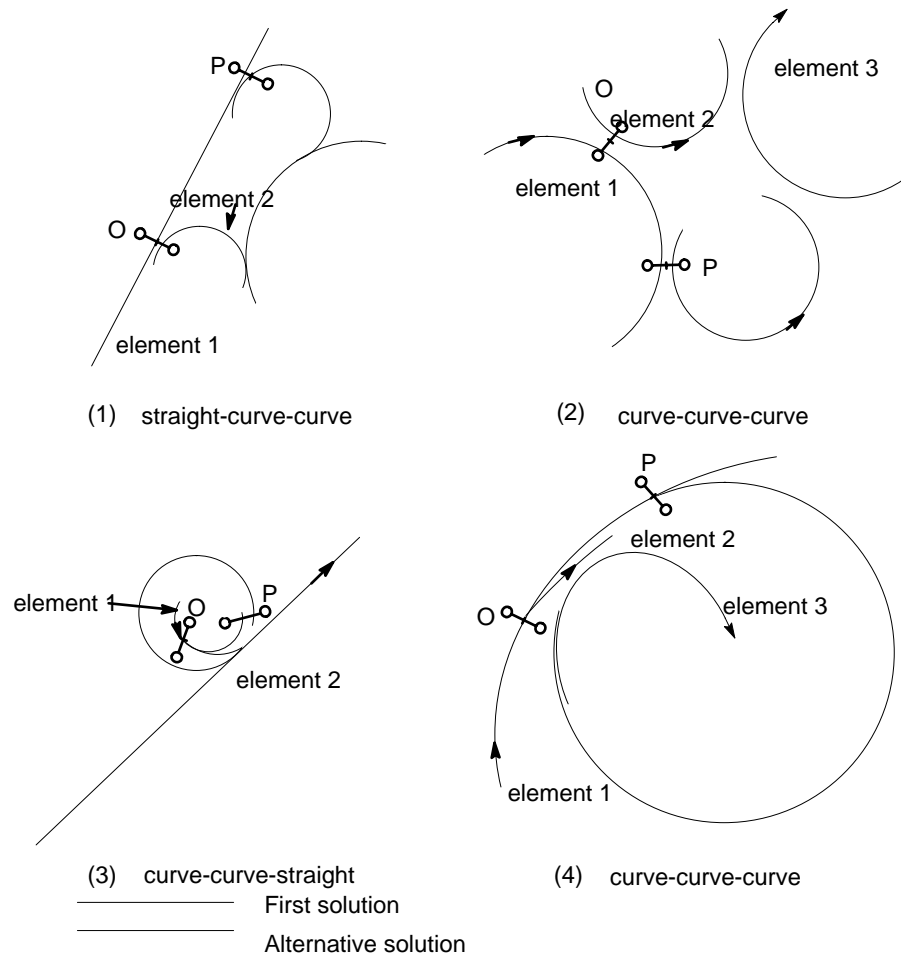


Figure 7 - 10 Situations requiring alternative solutions

## Transitions

### General properties

There are various properties and restrictions associated with transitions which can be summarised as follows.

- If no transitions are required between elements, they should not be specified.
- The adjacent elements in the alignment are fixed respectively to ensure that the specified transitions are accommodated.
- When there are two adjacent fixed elements, the second element is fixed without reference to the first. The transition length is calculated by an iterative process.
- To predetermine use of the A value rather than the RL value, where  $A = \sqrt{RL}$ , requires definition of the convention required at installation.

## Clothoid transitions

The parameters of the curves may be derived by one of the six methods

1. specify the transition length required
2. use a standard speed / RL ( or A) value, defined as part of the general input data
3. by choosing between the standard speed / RL (or A) value, the radius / 9, or a shift depending on the radius of the element.
4. by using a special speed / RL (or A) value
5. by applying French design rules based on road type and design speed
6. by applying C, S and summit curve transition length ratios between fixed elements.

For the third method of specifying transition length, the choice is decided by the option according to the following rule

1. if the radius is less than  $3.0 * \sqrt{RL}$ , the length is calculated from the standard RL value (as in method ii)
2. if the radius is larger than  $3.0 * \sqrt{RL}$ , but less than 15552.0 (imperial) or 4740.31 (metric), the length is given by  $\frac{R}{9}$ .
3. if the radius is larger than 15552.0 (imperial) or 4740.31 (metric), the transition length is given by:

$$8.0 * \sqrt{3.0 * R} \text{ for imperial}$$

$$8.0 * \sqrt{3.0 * \left( \frac{R}{3.2808} \right)} \text{ for metric.}$$

The reason for these choices is aesthetic to ensure that the angle consumed by a transition is not less than 3 degrees.

Various properties and restrictions of Clothoid transitions are summarised as follows

1. If two adjacent elements have the same hand (either left or right) part of the transition with the lowest RL value is fitted between the elements
2. The rate of change of lateral acceleration used in calculations of transition length and shift is  $1\text{ft}/\text{sec}^3$  or  $0.3047997\text{m}/\text{sec}^3$ . It should be noted that some published metric standard transition charts have adopted the value  $0.30 \text{ m}/\text{sec}^3$ .
3. For floating and free elements, partial transitions are used for compound curves. For free elements, two transitions need to be specified, one trailing and one leading and they should both have the same speed value. If they do not have the same speed value the lower non-zero value is taken. The common transition length between compound curves cannot be specified directly. To achieve this result, calculate the input values of either the common RL value or the transition length LA and LB as follows -



$$RL = \frac{LC \cdot R1 \cdot R2}{R1 - R2}$$

$$LC = \frac{RL}{R2} - \frac{RLR1 - R2}{R1 \cdot R2}$$

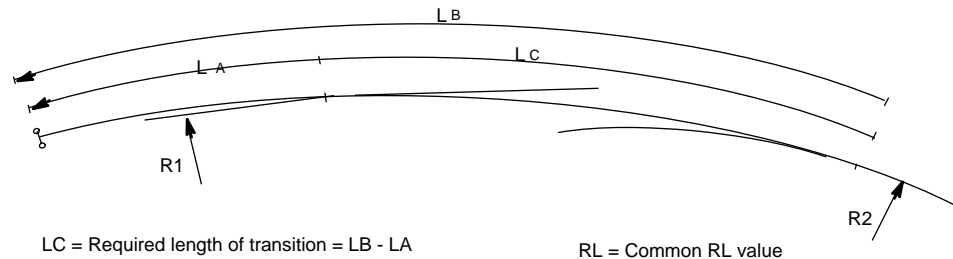


Figure 7 - 11 Calculation of input values

- When during analysis the trailing transition to an element attempts to start before the end of the element's leading transition because of the relationship of the element to the next, transition overlap occurs. If transition overlap occurs it indicates that the element is redundant and the design should be reconsidered.

### Bloss transitions

Bloss transitions have a special associated superelevation calculation which can be achieved using DESIGN minor options 132 and 135 .

Bloss transitions may only be specified by transition length.

The properties and restrictions of Bloss transitions are summarised as follows.

- the curvature of the Bloss transition varies with respect to distance according to the formula

$$K = \frac{3}{RL^2} \cdot l^2 - \frac{2}{RL^3} \cdot l^3$$

where  $K$  = curvature

$l$  = distance along transition

$R$  = radius of curve

$L$  = total length of transition

- If the transition is required between fixed elements then the length is determined by an iterative process, with an initial value based on current speed / RL (or A) value.
- ONLY straight-curve and curve-straight combinations are allowed. Straight-straight and curve-curve combinations are disallowed.

### Biquadratic parabolae transitions

Biquadratic Parabolae transitions may only be specified by transition length.

The properties and restrictions of Biquadratic Parabolae transitions are summarised as follows

1. the curvature of the Biquadratic transition varies with respect to distance according to the formula

$$\text{For } 0 \leq l \leq \frac{L}{2} \quad K = \frac{2}{RL^2} \cdot l^2$$

$$\text{For } \frac{L}{2} \leq l \leq L \quad K = \frac{4Ll - 2l^2 - L^2}{RL^2}$$

where  $K$  = curvature

$l$  = distance along transition

$R$  = radius of curve

$L$  = total length of transition

2. If the transition is required between fixed elements then the length is determined by an iterative process, with an initial value based on current speed / RL (or A) value.
3. ONLY straight-curve and curve-straight combinations are allowed. Straight-straight and curve-curve combinations are disallowed.

### Sine transitions

Sine transitions may only be specified by transition length.

The properties and restrictions of Sine transitions are summarised as follows:

1. the curvature of the Sine transition varies with respect to distance according to the formula

$$K = \frac{1}{2R} [1 - \cos \frac{\pi l}{L}]$$

where  $K$  = curvature

$l$  = distance along transition

$R$  = radius of curve

$L$  = total length of transition

2. If the transition is required between fixed elements then the length is determined by an iterative process, with an initial value based on current speed / RL (or A) value.
3. ONLY straight-curve and curve-straight combinations are allowed. Straight-straight and curve-curve combinations are disallowed.

### Cubic parabolae transitions

Cubic parabolae transitions may only be specified by transition length.

The properties and restrictions of Cubic transitions are summarised as follows

1. the curvature of the Cubic transition varies with respect to distance according to the formula:

$$K = \frac{x}{RL_x}$$

Coordinates (x,y) on the transition are defined by:

$$y = \frac{x^3}{6RL_x}$$

where  $K$  = curvature

$x$  = distance along along the tangent to the transition

$R$  = radius of curve

$l_x$  = total length of tangent to the transition

2. If the transition is required between fixed elements then the length is determined by an iterative process, with an initial value based on current speed / RL (or A) value.
3. ONLY straight-curve and curve-straight combinations are allowed. Straight-straight and curve-curve combinations are disallowed.

### Czech cubic transitions

Czech cubic transitions vary from standard cubic transitions in the following way:

1. the curvature of the Czech cubic transition varies with respect to distance according to the formula:

$$K = \lambda \frac{x}{RL_x} \cos \theta$$

2. Coordinates (x,y) on the transition are defined by:

$$y = \lambda \frac{x^3}{6RL_x}$$

where:

F is the angle between tangent  $CD$  and the tangent to the start of the transition

Q is the angle between tangent  $AB$  and the tangent to the start of the transition

$$\lambda = \frac{1}{\cos \phi}$$

- ◇ *Curve-curve combinations are allowed with Czech cubics, in addition to straight-curve and curve-straight combinations.*

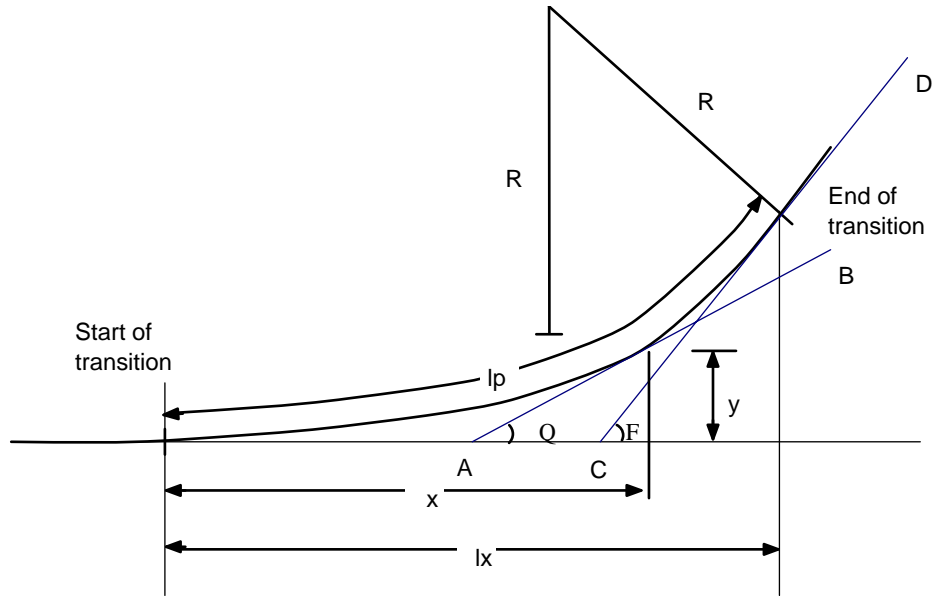


Figure 7 - 12 Czech cubic transition formulae

### Cubic transition formulae

#### French transition formulae

French design rules dictate the formulae to be used for transitions based on a function of the road and design speed. Within these rules transitions are calculated to ensure sufficient length is available to permit any necessary change of crossfall. The length of transition is also affected by Road Type, Road Speed, Number of Lanes and construction. See Figure 7 - 13 .

$$L_1 = 14d_1 - d_0$$

$$L_2 = \frac{R}{9}$$

$$L_1 = 14d_1 - d_0$$

$$L_2 = \frac{R}{9}$$

$$L_1 = 6R^{0.4}$$

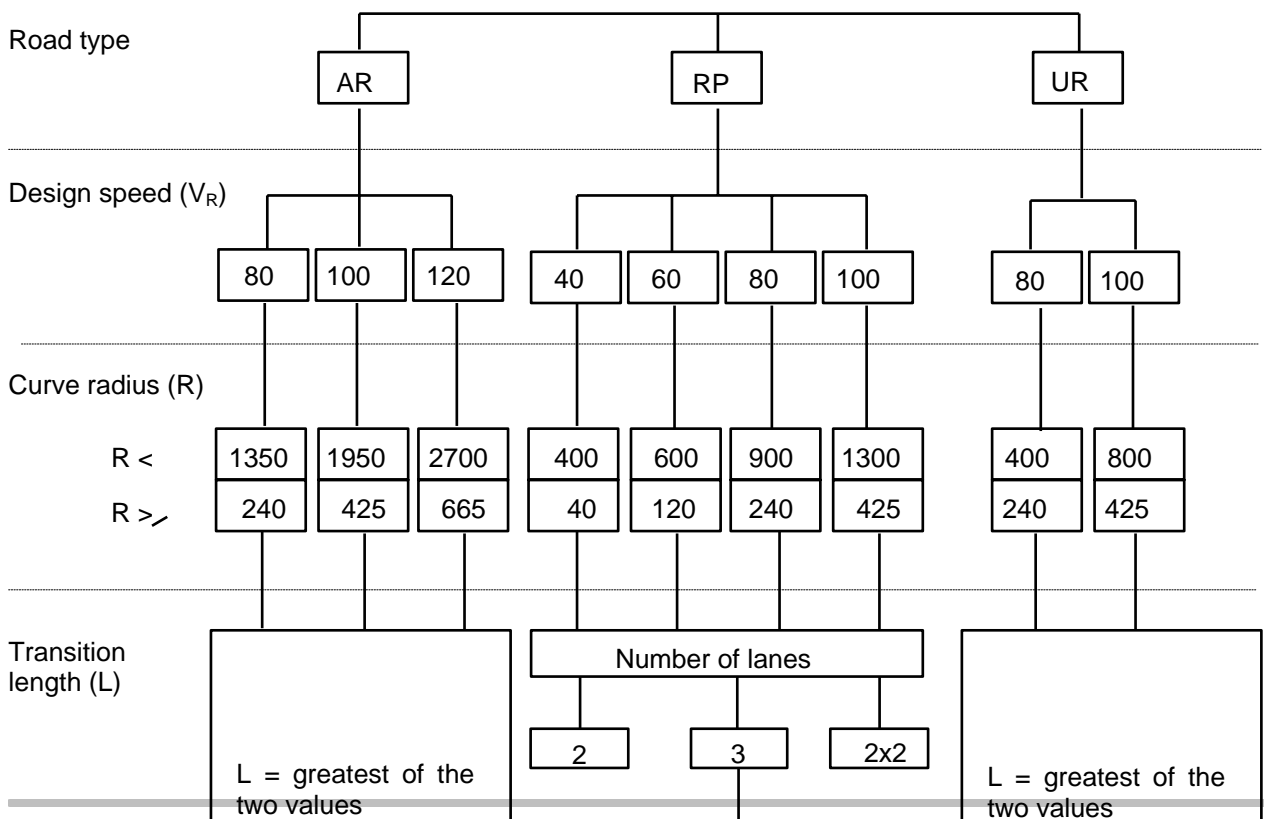
$$L_2 = 67$$

$$L_1 = 9R^{0.4}$$

$$L_2 = 100$$

$$L_1 = 12R^{0.4}$$

$$L_2 = 133$$



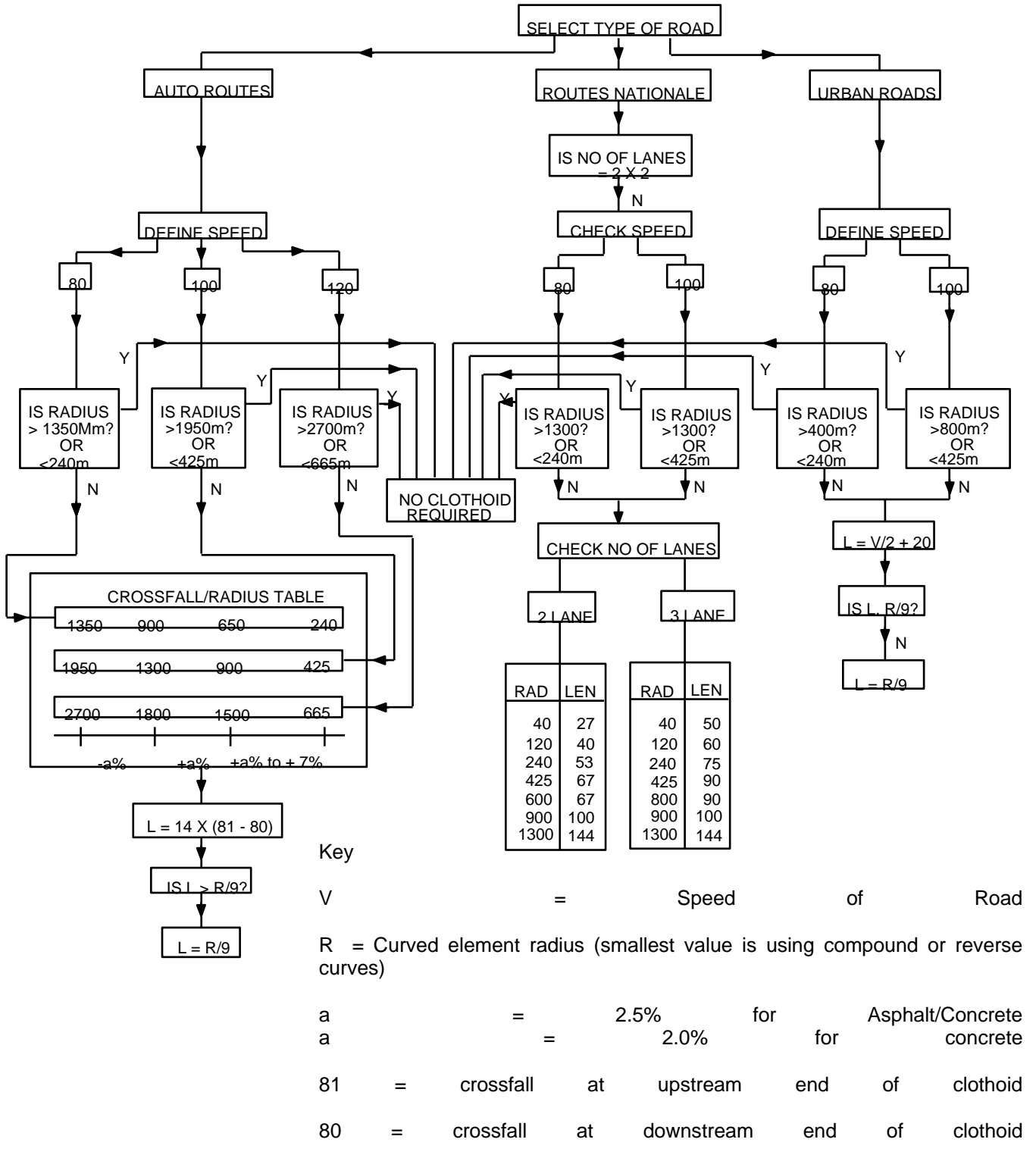


Figure 7 - 13 Automatic introduction of transition lengths

When an alignment includes a curve with a radius greater than the maximum radius allowed for the selected design speed, no transition is applied.

When an alignment includes a curve with a radius less than the minimum radius allowed for the selected design speed, the next lowest design speed is adopted for that curve only, and a warning is displayed.

When an alignment includes a curve with a radius which is less than the minimum radius allowed for the selected road type, the following action is taken:

- For AR and UR, the length corresponding to the maximum crossfall is adopted and a warning is displayed.
- For RP, the length corresponding to the minimum radius is adopted.

RP road type will allow a design speed of 40 kph, even though this is below the design standards, to give flexibility when designing alignments with unavoidably small radii.

RP road type will not allow 4 lanes on a road which has a design speed of 100kph.

### **C, S and wholly transitional (Summit) curves**

Between two fixed elements transitions may be derived to provide a continuously smooth alignment. C, S and wholly transitional (Summit) geometric constructions involve joining the two fixed elements with two transitions which meet at a common point with radius, bearing and chainage continuity at the common point. (Wholly transitional curves are called 'Summit curves' in France).

The type of curve involved, (C, S, or Summit) is determined automatically from the type and hand of the two fixed elements. In addition to these instructions you can have

- fix to fix of same hand with a single partial transition
- fix arc to fix straight with a single transition
- fix straight to fix arc with a single transition.

A common radius or the ratio of the transition lengths is given as data for defining the transition usage.

C - curves:

- preceding and following arcs must be of the same hand
- A common radius must be given and must be greater than those of the preceding or following arcs
- A transition constant ratio may be given but for most C curves this will be the default of 1
- If no common radius is given the connection will be attempted with a single part transition

S - curves

- Preceding and following arcs must be of opposite hand
- A common radius must not be given
- A transition constant may be given and if not a default of 1 will be taken.

Wholly transitional (Summit) curves

- preceding and following elements must be straight
  - A common radius must be given
  - A transition constant may be given if not the default of 1 will be used.
- In all the above cases an iterative technique to find the solution is taken.

### †Chord-to-arc tolerance

The MOSS system stores information as strings of points and because a straight line is assumed between successive points it is necessary to generate sufficient points on master alignment strings to ensure that the accuracy of the straight line representation in the horizontal plane is within a limit specified by the user. The tolerance used to govern the number of points required is the maximum chord to arc distance.

The horizontal alignment options create points at the specified chainage interval and also check the chord to arc distance against the specified tolerance. (The default chord-to-arc tolerance is determined by the variable AHDETOLR in the parameter file.) ~~@@@@(default 0.1)~~. If the tolerance is exceeded further points are introduced until the tolerance is satisfied.

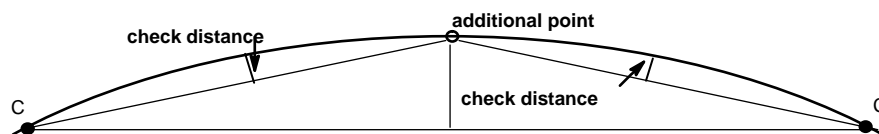


Figure 7 - 14 Chord-to-arc† tolerance

These additional points do not appear on the printed output from the horizontal alignment options but are stored in the string.

Because the vertical radii tend to be large it is not normally necessary to generate additional points to satisfy a tolerance in the vertical plane. If, however, the vertical tolerance is in doubt the horizontal alignment must be run at an appropriate interval or the horizontal tolerance reduced.

### Offset alignments

It is sometimes more convenient to define an element in terms of its relationship to another alignment rather than explicitly specifying the data. This may be achieved by giving the details of the relevant element of the previously computed offset alignment together with offset information.

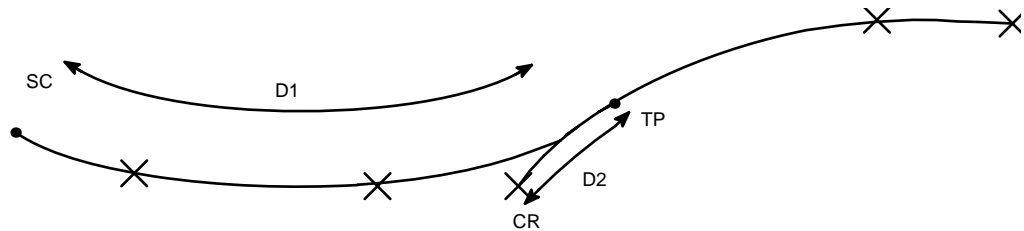
The offset element which may be a straight, curve, or transition, must be completely determined as to its type, its position and its bearing as well as its chainage datum. Once the offset element is defined the point from which the offset is to be made is given by its chainage and offset. It is then quite simple to define what information is to be transferred to the element definition record.



### Chainage datum reference

Usually the first defined point on the first element of an alignment provides the position of the chainage datum. However the program allows any defined point to be referenced as the datum, and it is also possible to reference the tangent point between two elements as being the chainage reference.

The chainage datum reference may be defined on any element record but if more than one is defined the last encountered reference is taken. The reference point may be defined via the offset element definition record. If the defined reference point does not itself lie on the computed alignment the chainage reference is still accommodated by referencing forwards or backwards to the associated tangent point between elements and calculating from that point.



**Figure 7 - 15 Chainage datum reference**

- CR = Chainage datum reference.
- SC = Start chainage of alignment.
- TP = Tangent point between the two elements.
- D2 = Calculate distance from CR to TP.

Derived chainage of T.P. = chainage of C.R. + D2

Coordinates of SC derived from chainage of SC - chainage of TP.

## Geometry strings

In addition to the digital string which stores points on the alignment at regular chainage intervals, a geometry string may be stored. This string holds all the information necessary to generate the digital string at a defined interval at a later stage. It may also be used to annotate drawings.

The interpretation of the codes in dimension 9 of the geometry string is shown below.

### Horizontal tangent point codes

Element Before	Code	Element After
None	PBC	Arc
None	PBT	Straight
Straight	PC	Arc
Arc	PT	Straight
Straight	TS	Spiral
Arc	CS	Spiral
Spiral	SC	Arc
Spiral	ST	Straight
Arc	PCC	Arc
Arc	PRC	Arc
Spiral	SS	Spiral
Arc	PAC	None
Straight	PAT	None

◇ *The codes PBC may be replaced by an alternative National code by editing the appropriate section of the parameter file.*

## Data preparation

Major option HALGN

- ~~1st~~ Model 1 Model in which the resultant alignment will be stored. If omitted the alignment is analysed but not stored.
- ~~2nd~~ Model 2 Model in which the geometry string will be stored. If omitted no geometry string is stored.  
The label of the geometry string will be the same as the master alignment but with the first character M replaced by G. Note that this same model name must be used as the second model name for the VALGN or VERAT options (which follows) for a particular alignment.

The data input for this option is completely FREE FORMAT and in an effort to simplify it a method has been developed which uses field descriptors for individual items of data. Note that only 79 columns on the input record may be used.

For example: RA = 1500 would infer a radius of 1500.  
whereas X1 = 1500, Y1 = 2000 would be interpreted as being the  
coordinates of first locating point.

Throughout the major option if Danish notation is currently in use the RL  
value should be defined as the A value ( $A = \sqrt{RL}$ ) and this convention is  
interpreted by the program.

◇ *Running this option with a string label that already exists will overwrite  
any levels with null levels.*

## Minor option 300 Initial data record

The field descriptor is given in the first column with a corresponding  
explanation in the second column.

LB	Code 4 character string label beginning with M.
SC	Start chainage Default value 0.0.
FC	End chainage Default value is either the last point on the element, or the 1st tangent point of the last element.
CF	Chainage of the first point on the first element. Default value 0.0.
TL	Chord to arc tolerance. Default value 0.1.
CE	Chainage interval on elements. Default value 10.0 (metric) or 25.0 (imperial).
CT	Chainage interval on transitions. Default value chainage interval on elements.
NR	Normal RL value. If the value lies between 10.0 and 150.0 it is taken as the design speed, and the RL value will be calculated as $0.07032 * NR^3$ (metric) $3.155 * NR^3$ (imperial) If the value is greater than 150 it is taken as the actual RL value. Default value 115.0 (metric) 70.0 (imperial)
MR	Minimum RL value. The same conventions are adopted as for NR The smaller of NR and MR is always adopted for MR.
NA	Normal A value.
MA	Minimum A value.
LE	This value is added to all eastings of points computed on the alignment. Default value 0.0.

LN	This value is added to all northings of points computed on the alignment. Default value 0.0.
RM	Minimum radius. A warning will be given if any point on the alignment has a radius falling below this value. Default value 0.0.
IM or ME	IMperial or METric units required. Default ME.
TR	For application of French transition formulae, code for Type of road
	AR      Autoroute (motorway) - default
	AR      Autoroute (default)
	RP      Route principale (major road)
	UR      Route urbaine (urban road)
	RN      Route-Nationale
	UR      Urban Roads
DS	Design speed (default value 120 kph)
MC	Minimum crossfall (related to construction of road) (default value 2.5)
NL	Number of lanes (only used when TR = RP)
NL	Number of lanes (only used when TR = RN)

The final 4 data items are used when designing roads specifically to French National Standards.

- ◇ *The default value for the parameter CE is obtained from the parameter file PRMDEF.DAT. The parameter is CRMCHINT.*
- ◇ *Output shows either A or RL values.*
- ◇ *You cannot mix A and RL within an alignment, an attempt to do so will result in an error.*

## Minor option 301    Element data

Code the element number:

If the element numbers on successive records are not in strictly ascending order they will be modified.

Default value is the next consecutive number.

Code the element type as follows:-

Element	Fix	Floating	Free
Straight	SX	SL	SE
Right hand curve	RX	RL	RE
Left hand curve	LX	LL	LE
Instantaneous radius (C, S, and summit curves)	CS	-	-

Code the following fields according to the element type and the form of the data:-

X1	Easting	)	Point P1
Y1	Northing	)	
X2	Easting	)	Point P2
Y2	Northing	)	
X3	Easting	)	Point P3
Y3	Northing	)	
XC	Easting	)	Centre of a curve
YC	Northing	)	

BE Bearing. The bearing may be defined in any of the ways generally available.

RA Radius of curve. For C, and Summit curves this will be the instantaneous common radius.

CU Angle of curvature. The angle may be defined in any of the ways generally available.

AS Alternative solution required.

C1 Chainage of the first point specifying this element.

C2 Chainage of the second point.

C3 Chainage of the third point

C4 Chainage of the tangent point at start of this element

C5 Chainage of the tangent point at end of this element.

Only one of the alternatives C1-C5 should occur in any complete alignment.

Note that minor option 302 may be used to supply any of the following fields from an offset alignment.

P1, P2, P3, BE, RA.

Any transitions associated with the element are also defined on this option and are either leading (L) or trailing (T).

**Clothoid transitions**

L1, T1 Transition length

L2, T2 No associated data; the transition length is calculated from the default RL value as defined on the minor option 300

L3, T3 No associated data: the transition length is determined according to:-

- 1) if the radius is less than  $3.0 * \sqrt{RL}$ , the transition length is calculated from the standard RL value defined on minor option 300.
- 2) if the radius is greater than 4740.31 (metric); 15552 (imperial) then the transition length is

$$8.0 * \sqrt{3.0 * \left( \frac{R}{3.2808} \right)} \text{ (metric)}$$

or

$$8.0 * \sqrt{3.0 * R} \text{ (imperial)}$$

- 3) if the radius lies between the above two limits the transition length is  $\frac{R}{9}$ .

L4, T4	RL value for Design Speed. If the speed is coded the transition length will be calculated from the RL value as derived for this speed.
L5, T5	No associated data: the transition length is calculated using the French transition formulae.
L6, T6	Transition constants defining the ratio of transitions for C,S, and summit curves (default L6 = 1, T6 = 1)
L7, T7	Use default A value to compute transition length
L8, T8	Use A value to compute transition length

### Bloss transitions

LA, TA	Transition length
LG, TG	No associated data; used for transitions between fixed elements.

### Cubic transitions

LB, TB	Transition length
LH, TH	No associated data; used for transitions between fixed elements.

- ◇ *Cubic transition lengths may be specified along the tangent to the curve or along the curve itself, depending upon the setting of the parameter CUBILENG in the parameter file.*
- ◇ *Czech cubic transitions may be activated by modifying the parameter CUBIFACT in the parameter file.*

*See Chapter 2, 'Throughout MOSS', for details of how to modify the parameter file.*

### Biquadratic transitions

LC, TC	Transition length
LK, TK	No associated data; used for transitions between fixed elements.

### Sine transitions

LD, TD	Transition length
LJ, TJ	No associated data; used for transitions between fixed elements.

If transitions are not required the transition fields are not submitted.

- ◇ *Output shows either A or RL values.*
- ◇ *You cannot mix A and RL within an alignment, an attempt to do so will result in an error.*

## Minor option 302    **Offset alignment**

This minor option may be used in the definition of the foregoing element details by reference to an element on some other alignment. The relevant element (or transition) is known as a segment.

Code the segment type

ST	Straight
CL	Curve (left hand)
CR	Curve (right hand)
TL	Transition (left hand)
TR	Transition (right hand)

A point on the segment must be defined by all of the following fields. If the segment is a transition the point defined must be the origin of the transition.

OX	Easting
OY	Northing
OB	Bearing. This may be defined in any of the ways generally available.
OC	Chainage
RD	Radius (only if segment is a curve)
RL	RL value (only if segment is a transition)

The segment is now completely defined. On subsequent offset alignment records if the same segment is to be used all the above fields may be recalled by coding.

PA	Previous alignment
----	--------------------

The following two fields define the offset points and both are needed.

CO	Chainage that offset is to be made
LO	Distance of offset point on new alignment from the defined segment to the left.
	or
RO	Distance of offset point on new alignment from the defined segment to the right.

From the information so far given on this minor option the offset point is uniquely defined by coordinates, tangent bearing and radius. Some or all of these details may be transferred to the previous 301 option by specifying:-

P1	Move the coordinates to P1 or
P2	Move the coordinates to P2 or
P3	Move the coordinates to P3
RA	Move the radius
BE	Move the bearing or
BR	Move the bearing rotated through 180 degrees.

**Example of data input for offset alignment.**

The following is a valid combination of fields.

```
301, 1, RX, X3=450, Y3=901.3
302, CL, OX=500, OY=950, OB=1832251.6, OC=300, RD=785, CO=310, LO=5, P1
302, PA, CO=280, LO=8, P2
301, 2, SX
302, PA, CO=380, LO=15.7, BE, P1
```

◇ *Note that PA will only recall the latest segment definition*

**Minor option 303 Special chainages**

There are no field descriptors on this record which simply defines those special chainages at which the user required information. Up to 100 special chainages may be requested but they must be given in strictly increasing chainage.

**Minor option 304 Special chainage intervals**

Up to 100 special chainage intervals may be requested. The start and end chainages must lie within the limits of the start and finish chainages defined on minor option 300. The start chainage for a special chainage interval must lie after the end chainage of a foregoing special chainage interval. All three of the following fields must be coded.

SC	Start chainage.
FC	End chainage.
CI	Chainage interval.

When a special chainage interval is defined the chainage points within that interval are not multiples of the chainage interval, but are determined as chainage intervals from the start chainage specified for that special chainage range.

Thus 304, SC=123.4, FC=156.7, CI=10.0



embedded within a start chainage of 0 and an end chainage of 200.0 with a chainage interval of 20 for the whole run would produce the following chainage points

0, 20, 40, 60, 80, 100, 120, 123.4, 133.4, 143.4, 153.4, 156.7, 160, 180, 200

## Minor option 305 Continuation record

For minor options 300, 301, or 302 the quantity of data may necessitate continuation onto another 80 column record. This may be accommodated by invoking minor option 305 and simply continuing with the data input. There is no limit to the number of such continuation records.

## Output

Comprehensive primary analyses and element and transition summaries are followed by a complete listing of the alignment, showing the alignment at all chainage points be they ordinary points, special chainage points, or points within a special chainage interval. Points of specific importance are annotated.

The secondary analyses are provided to high accuracy so that the curves or transitions may be reconstituted independently if required.

The string which is stored within the model will contain all the points shown together with others if the chord to arc tolerance dictates that the chainage interval is too large.

In addition to the digital string stored, a Geometry String may be stored, if a second model name has been specified.

The Geometry string may subsequently be used for regenerating the alignment at different chainage intervals or for the annotation of drawings.

- ◇ *Errors E322 and E323 will occur where input data may be too fixed, or where intersections of elements occur.*

*MOSS will warn the user and suggest revised element data.*

*The revised element data is provided to indicate the location of the error only. The revised data and solution provided must be carefully checked before adoption.*

## Examples

There are three examples. The first is a straight forward eight element alignment, whilst the second example illustrates the complexity with which an alignment may be defined. The third example shows how imperial units may be invoked.

### Example 1

Input data:

MOSS

HALGN, EXAMPLE MODEL1

300, SC=600, FC=1800, CF=600, CE=100, CT=10, NR=21485.922, MR=480,  
LB=M001

301, 05, SX, X1=543561.831, Y1=196981.965, X2=543628.603, Y2=196937.902

301, 06, RL, RA=325, X2=543769.500, Y2=196814.250, T2, L2

301, 07, LL, RA=1350, X2=543867.500, Y2=196842.750, L2, T2

301, 08, RE, RA=325, L2, T2

301, 09, SX, X1=543983.201, Y1=196441.024, X2=543990.680, Y2=196422.475

301, 10, LE, RA=650, L2, T2

301, 11, SX, X2=544094.516, Y2=196229.478, X1=544052.748, Y1=196297.739

301, 12, RL, RA=1750, X2=544180, Y2=196052, L2  
999

Output data:

HALGN EXAMPLE MODEL1  
DATA ANALYSIS-----

300, SC=600, FC=1800, CF=600, CE=100, CT=10, NR=21485.922, MR=480, LB=M001  
301, 05, SX, X1=543561.831, Y1=196981.965, X2=543628.603, Y2=196937.902  
301, 06, RL, RA=325, X2=543769.500, Y2=196814.250, T2, L2  
301, 07, LL, RA=1350, X2=543867.500, Y2=196842.750, L2, T2

W353 P1 NOT ENTERED  
P2 CHANGED TO P1

301, 08, RE, RA=325, L2, T2

W353 P1 NOT ENTERED  
P2 CHANGED TO P1

301, 09, SX, X1=543983.201, Y1=196441.024, X2=543990.680, Y2=196422.475  
301, 10, LE, RA=650, L2, T2  
301, 11, SX, X2=544094.516, Y2=196229.478, X1=544052.748, Y1=196297.739  
301, 12, RL, RA=1750, X2=544180, Y2=196052, L2  
999

W353 P1 NOT ENTERED  
P2 CHANGED TO P1

TRANSITION DATA-----

DESIGN VALUE INPUT 21485.922  
MINIMUM DESIGN VALUE INPUT 480.000  
DESIGN SPEED ADOPTED 67.353  
NORMAL RL ADOPTED 21485.922  
MINIMUM RL ADOPTED 480.000

ELEMENT DATA-----

EL	TYPE	XO	YO	XP	YP	XQ	YQ	WCB-	DMS	RADIUS	L-TRANS	T-TRANS	AS
5	FIX S	0.000	0.000	543561.831	196981.965	543628.603	196937.902	123	25	15.3	INFINITY	0	0.000 0 0.000
6	FLO R	0.000	0.000	543769.500	196814.250	0.000	0.000	0	0	0.0	325.000	2	0.000 2 0.000
7	FLO L	0.000	0.000	543867.500	196842.750	0.000	0.000	0	0	0.0	1350.000	2	0.000 2 0.000
8	FRE R	0.000	0.000	0.000	0.000	0.000	0.000	0	0	0.0	325.000	2	0.000 2 0.000
9	FIX S	0.000	0.000	543983.201	196441.024	543990.680	196422.475	158	2	26.1	INFINITY	0	0.000 0 0.000
10	FRE L	0.000	0.000	0.000	0.000	0.000	0.000	0	0	0.0	650.000	2	0.000 2 0.000
11	FIX S	0.000	0.000	544052.748	196297.739	544094.516	196229.478	148	32	17.1	INFINITY	0	0.000 0 0.000
12	FLO R	0.000	0.000	544180.000	196052.000	0.000	0.000	0	0	0.0	1750.000	2	0.000 0 0.000

SECONDARY ANALYSIS-----

SOLUTION 2 FOR ELEMENT 8 IS AT 542679.93137 198802.72196  
SOLUTION 1 USED FOR ELEMENT 8

ELEMENT SUMMARY-----

-CHAINAGE -X- -Y- -WCB-DMS -RADIUS- -LENGTH- EL

START 600.000 543561.83100 196981.96500 123 25 15.3

END	707.562	543651.60693	196922.72166	123	25	15.3	INFINITY	107.562	5
START	773.672	543705.49524	196884.47725	129	14	54.2			
END	2696.781	543601.82580	196941.38847	108	16	56.6			
CENTRE		543499.87311	196632.79383				325.000	1923.109	6
START	2778.808	543677.56141	196909.98265	113	46	19.6			
END	11238.490	543656.94010	196919.27277	114	43	55.3			
CENTRE		544221.74642	198145.44316				-1350.000	8459.683	7
START	11320.516	543730.64299	196883.35493	120	13	18.4			
END	11501.981	543854.57832	196754.03756	152	12	47.2			
CENTRE		543567.05479	196602.52776				325.000	181.465	8
START	11568.092	543881.35196	196693.62433	158	2	26.1			
END	11863.553	543991.83960	196419.59903	158	2	26.1			
							INFINITY	295.461	9
START	11896.608	544004.45963	196389.04870	156	35	1.4			
END	11971.356	544038.03889	196322.31471	149	59	41.8			
CENTRE		544600.92679	196647.36426				-650.000	74.747	10
START	12004.411	544055.05139	196293.97459	148	32	17.1			
END	12007.972	544056.90995	196290.93716	148	32	17.1			
							INFINITY	3.561	11
START	12020.249	544063.30581	196280.45698	148	44	20.7			
END	12277.015	544180.00000	196052.00000	157	8	44.5			
CENTRE		542567.38312	195372.31860				1750.000	256.765	12

TRANSITION SUMMARY-----

	-CHAINAGE-	---SHIFT---	--C-VALUE--	-RL VALUE--		--LENGTH--	EL
TRAIL	707.562	0.000	0.000	0.000		0.000	5
LEAD	773.672	0.560	33.044	21485.922		66.111	6
ORIGIN	(X,Y,CHAIN,WCB-DMS )		543651.60693	196922.72166	707.562	123 25 15.3	
TRAIL	2696.781	0.560	33.044	21485.922		66.111	6
LEAD	2778.808	0.008	7.958	21485.922		15.915	7
ORIGIN	(X,Y,CHAIN,WCB-DMS )		543663.02160	196916.45536	2762.892	114 6 35.5	
TRAIL	11238.490	0.008	7.958	21485.922		15.915	7
LEAD	11320.516	0.560	33.044	21485.922		66.111	8
ORIGIN	(X,Y,CHAIN,WCB-DMS )		543671.42177	196912.67099	11254.406	114 23 39.5	
TRAIL	11501.981	0.560	33.044	21485.922		66.111	8
LEAD	11568.092	0.000	0.000	0.000		0.000	9
ORIGIN	(X,Y,CHAIN,WCB-DMS )		543881.35196	196693.62433	11568.092	158 2 26.1	
TRAIL	11863.553	0.000	0.000	0.000		0.000	9
LEAD	11896.608	0.070	16.527	21485.922		33.055	10
ORIGIN	(X,Y,CHAIN,WCB-DMS )		543991.83960	196419.59903	11863.553	158 2 26.1	
TRAIL	11971.356	0.070	16.527	21485.922		33.055	10
LEAD	12004.411	0.000	0.000	0.000		0.000	11
ORIGIN	(X,Y,CHAIN,WCB-DMS )		544055.05139	196293.97459	12004.411	148 32 17.1	
TRAIL	12007.972	0.000	0.000	0.000		0.000	11
LEAD	12020.249	0.004	6.139	21485.922		12.278	12
ORIGIN	(X,Y,CHAIN,WCB-DMS )		544056.90995	196290.93716	12007.972	148 32 17.1	

INITIAL DATA -----

LABEL	=	M001
START CHAINAGE	=	600.000
FINISH CHAINAGE	=	1800.000
CHAINAGE OF FIRST POINT	=	600.000
CHAINAGE INTERVAL-ELEMENTS	=	100.0
CHAINAGE INTERVAL-TRANSITIONS	=	10.0
TOLERANCE	=	0.100
UNITS	=	METRIC
DESIGN SPEED	=	67.353
NORMAL RL VALUE	=	21485.922
MINIMUM RL VALUE	=	480.000
MINIMUM DESIGN RADIUS	=	-999999.9
LOCALISED EASTING	=	0.000
LOCALISED NORTHING	=	0.000
NO OF SPECIAL CHAINAGES	=	0
NO OF SPECIAL CHAINAGE INTERVALS	=	0

ALIGNMENT DETAILS -----

ELEMENT	CHAINAGE	C O O R D I N A T E S			BEARING DEG MIN SEC	RADIUS OF CURVATURE	RATE OF CHANGE LATERAL ACCEL.
		-----X----	-----Y----				
TANGENT POINT-PB	600.000	543561.831	196981.965	123 25 15.3	INFINITY	0.00000	
	5	610.000	543570.177	196976.457	123 25 15.3	0.00000	
	5	700.000	543645.296	196926.886	123 25 15.3	0.00000	
TANGENT POINT-TS	707.562	543651.607	196922.722	123 25 15.3	INFINITY	0.00000	

L	710.000	543653.642	196921.379	123	25	43.8	8811.4	0.30480
L	720.000	543661.980	196915.858	123	37	37.9	1727.4	0.30480
L	730.000	543670.287	196910.290	124	5	32.0	957.6	0.30480
L	740.000	543678.534	196904.635	124	49	26.1	662.4	0.30480
L	750.000	543686.695	196898.856	125	49	20.2	506.3	0.30480
L	760.000	543694.741	196892.918	127	5	14.3	409.7	0.30480
L	770.000	543702.639	196886.785	128	37	8.4	344.1	0.30480
TANGENT POINT-SC	773.672	543705.495	196884.477	129	14	54.2	325.0	0.00000
6	780.000	543710.356	196880.426	130	21	50.2	325.0	0.00000
6	800.000	543725.187	196867.013	133	53	23.5	325.0	0.00000
6	900.000	543785.541	196787.774	151	31	9.6	325.0	0.00000
6	1000.000	543819.062	196693.978	169	8	55.7	325.0	0.00000
6	1100.000	543822.601	196594.435	186	46	41.8	325.0	0.00000
6	1200.000	543795.827	196498.495	204	24	27.8	325.0	0.00000
6	1300.000	543741.254	196415.170	222	2	13.9	325.0	0.00000
6	1400.000	543664.008	196352.286	239	40	0.0	325.0	0.00000
6	1500.000	543571.344	196315.750	257	17	46.1	325.0	0.00000
6	1600.000	543471.968	196308.994	274	55	32.2	325.0	0.00000
6	1700.000	543375.212	196332.653	292	33	18.3	325.0	0.00000
6	1800.000	543290.166	196384.504	310	11	4.4	325.0	0.00000

END OF ALIGNMENT -----

Example 2

Input data:

```

MOSS
HALGN, EXAMPLE MODEL2
    THE INPUT ANGLE DEFINITION IS DMS BUT THE OUTPUT
ANGLE IS
    RADIANS
017, 2=RADI
300, LB=M002, FC=950, NR=115, CE=10
301, 1, LX, RA=2000

302, TL, RL=461621.737, OB=0320419.0, OX=5081.487, OY=11766.6
77, OC=7710
305, CO=7650, LO=9.95, P1
302, PA, CO=7610, LO=10.5, P2
301, 2, SL
302, CR, RD=8250, OB=0322822, OX=4968.065, OY=11589.943, OC=75
00
305, CO=7450, LO=12.8, P1
301, 3, LL, RA=2000
302, PA, CO=7400, LO=14.1, P1
301, 4, RE, RA=2000
301, 5, SX
302, PA, CO=7320, LO=15.55, P1
302, PA, CO=7190, LO=22.05, P2
301, 6, RL, RA=494
302, PA, CO=7000, LO=56.25, P1
301, 7, LE, RA=500
301, 8, SX
302, CR, RD=56.87, OB=3171900, OX=4602.524, OY=11050.396, OC=3
10
305, CO=407.2, LO=12.2, P1
302, PA, CO=391.5, LO=14, P2
301, 9, RL, RA=45.0, X1=4555.5, Y1=11123.675
301, 10, RE, RA=900
301, 11, SX, X1=4450, Y1=11162.5, X2=4400, Y2=11183
999
    
```

Output data:

```

HALGN  EXAMPLE MODEL2
DATA ANALYSIS-----
    THE INPUT ANGLE DEFINITION IS DMS BUT THE OUTPUT ANGLE IS RADIANS
017, 2=RADI
017    RADI

W120 SYSTEM VALUES HAVE BEEN MODIFIED
VALUES ADOPTED :
SEARCH TOLERANCE      0.0100
LEFT OFFSETS          -100.0000
RIGHT OFFSETS         100.0000
SECONDARY TOLERANCE   20.0000
SECONDARY OFFSET     20.0000
REFERENCE ANGLE       0.00000
CURVE FITTING INVOKED
    
```



# CHAPTER 7 MAJOR OPTION HALGN

STANDARD CONTENTS 7700  
 STATIONS STRING PSSA  
 ANGLE DEFINITION:  
 INPUT: NORM OUTPUT: RADI  
 COORDINATE DEFINITION:  
 INPUT: XY OUTPUT: XY  
 STANDARD DESIGN RULES APPLIED.

300, LB=M002, FC=950, NR=115, CE=10  
 301, 1, LX, RA=2000  
 302, TL, RL=461621.737, OB=0320419.0, OX=5081.487, OY=11766.677, OC=7710  
 305, CO=7650, LO=9.95, P1  
 302, PA, CO=7610, LO=10.5, P2  
 301, 2, SL  
 302, CR, RD=8250, OB=0322822, OX=4968.065, OY=11589.943, OC=7500  
 305, CO=7450, LO=12.8, P1  
 301, 3, LL, RA=2000  
 302, PA, CO=7400, LO=14.1, P1  
 301, 4, RE, RA=2000  
 301, 5, SX  
 302, PA, CO=7320, LO=15.55, P1  
 302, PA, CO=7190, LO=22.05, P2  
 301, 6, RL, RA=494  
 302, PA, CO=7000, LO=56.25, P1  
 301, 7, LE, RA=500  
 301, 8, SX  
 302, CR, RD=56.87, OB=3171900, OX=4602.524, OY=11050.396, OC=310  
 305, CO=407.2, LO=12.2, P1  
 302, PA, CO=391.5, LO=14, P2  
 301, 9, RL, RA=45.0, X1=4555.5, Y1=11123.675

301, 10, RE, RA=900  
 301, 11, SX, X1=4450, Y1=11162.5, X2=4400, Y2=11183  
 999

OFFSET ELEMENT ANALYSIS-----

	-CHAINAGE-	-----X-----	-----Y-----	-WCB-DMS-	--RADIUS--	--OFFSET-	EL
M.L.	7650.000	5049.56194	11715.87556	32 17 43.3	7693.696		
POINT		5041.15116	11721.19169			-9.950	1
M.L.	7610.000	5028.08331	11682.13150	32 41 33.1	4616.217		
POINT		5019.24671	11687.80287			-10.500	1
M.L.	7450.000	4941.34805	11547.67958	32 7 31.9	8250.000		
POINT		4930.50792	11554.48631			-12.800	2
M.L.	7400.000	4914.88773	11505.25501	31 46 41.8	8250.000		
POINT		4902.90142	11512.68055			-14.100	3
M.L.	7320.000	4873.08743	11437.04442	31 13 21.7	8250.000		
POINT		4859.78970	11445.10501			-15.550	5
M.L.	7190.000	4806.57855	11325.34742	30 19 11.4	8250.000		
POINT		4787.54453	11336.47885			-22.050	5
M.L.	7000.000	4712.55850	11160.24553	29 0 1.1	8250.000		
POINT		4663.36129	11187.51633			-56.250	6
M.L.	407.200	4611.90952	11135.67467	55 14 39.8	56.870		
POINT		4604.95458	11145.69808			-12.200	8
M.L.	391.500	4600.40137	11125.06849	39 25 36.7	56.870		
POINT		4589.58727	11133.95979			-14.000	8

TRANSITION DATA-----

DESIGN VALUE INPUT 115.000  
 MINIMUM DESIGN VALUE INPUT 0.000  
 DESIGN SPEED ADOPTED 115.000  
 NORMAL RL ADOPTED 106947.558  
 MINIMUM RL ADOPTED 106947.558

ELEMENT DATA-----

EL TYPE	XO	YO	XP	YP	XQ	YQ	WCB- DMS	RADIUS	L-TRANS	T-TRANS
1 FIX L	6702.371	10607.483	5041.151	11721.192	5019.247	11687.803	0 0 0.0	2000.000	0	0.000
2 FLO S	0.000	0.000	4930.508	11554.486	0.000	0.000	0 0 0.0	INFINITY	0	0.000
3 FLO L	0.000	0.000	4902.901	11512.681	0.000	0.000	0 0 0.0	2000.000	0	0.000
4 FRE R	0.000	0.000	0.000	0.000	0.000	0.000	0 0 0.0	2000.000	0	0.000
5 FIX S	0.000	0.000	4859.790	11445.105	4787.545	11336.479	213 37 37.6	INFINITY	0	0.000
6 FLO R	0.000	0.000	4663.361	11187.516	0.000	0.000	0 0 0.0	494.000	0	0.000
7 FRE L	0.000	0.000	0.000	0.000	0.000	0.000	0 0 0.0	500.000	0	0.000
8 FIX S	0.000	0.000	4604.955	11145.698	4589.587	11133.960	232 37 32.4	INFINITY	0	0.000
9 FLO R	0.000	0.000	4555.500	11123.675	0.000	0.000	0 0 0.0	45.000	0	0.000
0 FRE R	0.000	0.000	0.000	0.000	0.000	0.000	0 0 0.0	900.000	0	0.000
1 FIX S	0.000	0.000	4450.000	11162.500	4400.000	11183.000	292 17 37.1	INFINITY	0	0.000

SECONDARY ANALYSIS-----

SOLUTION 2 FOR ELEMENT 4 IS AT 3315.51887 12734.68081  
 SOLUTION 1 USED FOR ELEMENT 4  
 SOLUTION 2 FOR ELEMENT 7 IS AT 5007.17429 10823.75402  
 SOLUTION 1 USED FOR ELEMENT 7  
 SOLUTION 2 FOR ELEMENT 10 IS AT 4943.00061 11933.07782  
 SOLUTION 1 USED FOR ELEMENT 10

ELEMENT SUMMARY-----

	-CHAINAGE-	-----X-----	-----Y-----	-WCB-RADI-	--RADIUS-	--LENGTH--	EL
START	0.000	5041.15116	11721.19169		3.73219		
END	9.515	5035.87161	11713.27602		3.72743		
CENTRE		6702.37139	10607.48287	-2000.000		9.515	1

START	9.515	5035.87161	11713.27602	3.72743		
END	229.094	4914.46699	11530.31163	3.72743		
					INFINITY	219.579 2
START	229.094	4914.46699	11530.31163	3.72743		
END	284.577	4884.43577	11483.66085	3.69969		
CENTRE		6580.96677	10424.51848		-2000.000	55.483 3
START	284.577	4884.43577	11483.66085	3.69969		
END	342.195	4853.22327	11435.23187	3.72850		
CENTRE		3187.90477	12542.80322		2000.000	57.618 4
START	342.195	4853.22327	11435.23187	3.72850		
END	511.400	4759.51986	11294.34160	3.72850		
					INFINITY	169.205 5
START	511.400	4759.51986	11294.34160	3.72850		
END	711.004	4618.84254	11154.65498	4.13255		
CENTRE		4348.18619	11567.91172		494.000	199.604 6
START	711.004	4618.84254	11154.65498	4.13255		
END	747.238	4589.27629	11133.72225	4.06008		
CENTRE		4892.78622	10736.37892		-500.000	36.234 7
START	747.238	4589.27629	11133.72225	4.06008		
END	749.034	4587.84869	11132.63178	4.06008		
					INFINITY	1.796 8
START	749.034	4587.84869	11132.63178	4.06008		
END	792.537	4546.61605	11125.59871	5.02680		
CENTRE		4560.53280	11168.39268		45.000	43.502 9
START	792.537	4546.61605	11125.59871	5.02680		
END	859.750	4483.53299	11148.75147	5.10149		
CENTRE		4824.95094	11981.47819		900.000	67.213 10
START	859.750	4483.53299	11148.75147	5.10149		
END	950.031	4400.00000	11183.00000	5.10149		
					INFINITY	90.281 11

INITIAL DATA -----

LABEL	=	M002
START CHAINAGE	=	0.000
FINISH CHAINAGE	=	950.000
CHAINAGE OF FIRST POINT	=	0.000
CHAINAGE INTERVAL-ELEMENTS	=	10.0
CHAINAGE INTERVAL-TRANSITIONS	=	10.0
TOLERANCE	=	0.100
UNITS	=	METRIC
DESIGN SPEED	=	115.000
NORMAL RL VALUE	=	106947.558
MINIMUM RL VALUE	=	106947.558
MINIMUM DESIGN RADIUS	=	-999999.9
LOCALISED EASTING	=	0.000
LOCALISED NORTHING	=	0.000
NO OF SPECIAL CHAINAGES	=	0
NO OF SPECIAL CHAINAGE INTERVALS	=	0

ALIGNMENT DETAILS -----

ELEMENT	CHAINAGE	C O O R D I N A T E S		BEARING -RADIANS-	RADIUS OF CURVATURE	RATE OF CHANGE LATERAL ACCEL.
		-----X-----	-----Y-----			
TANGENT POINT-PB	0.000	5041.151	11721.192	3.73219	-2000.0	0.00000
TANGENT POINT-PT	9.515	5035.872	11713.276	3.72743	-2000.0	0.00000
TANGENT POINT-PT	9.515	5035.872	11713.276	3.72743	INFINITY	0.00000
2	10.000	5035.603	11712.872	3.72743	INFINITY	0.00000
2	20.000	5030.074	11704.539	3.72743	INFINITY	0.00000
2	30.000	5024.545	11696.207	3.72743	INFINITY	0.00000
2	40.000	5019.016	11687.874	3.72743	INFINITY	0.00000
2	50.000	5013.487	11679.542	3.72743	INFINITY	0.00000
2	60.000	5007.959	11671.209	3.72743	INFINITY	0.00000
2	70.000	5002.430	11662.877	3.72743	INFINITY	0.00000
2	80.000	4996.901	11654.544	3.72743	INFINITY	0.00000
2	90.000	4991.372	11646.212	3.72743	INFINITY	0.00000
2	100.000	4985.843	11637.879	3.72743	INFINITY	0.00000
2	110.000	4980.314	11629.547	3.72743	INFINITY	0.00000
2	120.000	4974.785	11621.214	3.72743	INFINITY	0.00000
2	130.000	4969.256	11612.882	3.72743	INFINITY	0.00000
2	140.000	4963.727	11604.549	3.72743	INFINITY	0.00000
2	150.000	4958.198	11596.217	3.72743	INFINITY	0.00000
2	160.000	4952.669	11587.884	3.72743	INFINITY	0.00000
2	170.000	4947.140	11579.552	3.72743	INFINITY	0.00000
2	180.000	4941.611	11571.219	3.72743	INFINITY	0.00000
2	190.000	4936.082	11562.887	3.72743	INFINITY	0.00000
2	200.000	4930.553	11554.554	3.72743	INFINITY	0.00000
2	210.000	4925.024	11546.222	3.72743	INFINITY	0.00000
2	220.000	4919.495	11537.889	3.72743	INFINITY	0.00000
TANGENT POINT-PC	229.094	4914.467	11530.312	3.72743	INFINITY	0.00000
TANGENT POINT-PC	229.094	4914.467	11530.312	3.72743	-2000.0	0.00000
3	230.000	4913.966	11529.557	3.72698	-2000.0	0.00000
3	240.000	4908.462	11521.208	3.72198	-2000.0	0.00000
3	250.000	4902.999	11512.832	3.71698	-2000.0	0.00000
3	260.000	4897.579	11504.428	3.71198	-2000.0	0.00000
3	270.000	4892.200	11495.998	3.70698	-2000.0	0.00000
3	280.000	4886.864	11487.541	3.70198	-2000.0	0.00000
TANGENT POINT-PRC	284.577	4884.436	11483.661	3.69969	-2000.0	0.00000
TANGENT POINT-PRC	284.577	4884.436	11483.661	3.69969	2000.0	0.00000
4	290.000	4881.558	11479.065	3.70240	2000.0	0.00000
4	300.000	4876.218	11470.610	3.70740	2000.0	0.00000

4	310.000	4870.836	11462.182	3.71240	2000.0	0.00000
4	320.000	4865.412	11453.781	3.71740	2000.0	0.00000
4	330.000	4859.946	11445.407	3.72240	2000.0	0.00000
4	340.000	4854.438	11437.060	3.72740	2000.0	0.00000
TANGENT POINT-PT	342.195	4853.223	11435.232	3.72850	2000.0	0.00000
TANGENT POINT-PT	342.195	4853.223	11435.232	3.72850	INFINITY	0.00000
5	350.000	4848.901	11428.733	3.72850	INFINITY	0.00000
5	360.000	4843.363	11420.406	3.72850	INFINITY	0.00000
5	370.000	4837.825	11412.080	3.72850	INFINITY	0.00000
5	380.000	4832.287	11403.753	3.72850	INFINITY	0.00000
5	390.000	4826.750	11395.427	3.72850	INFINITY	0.00000
5	400.000	4821.212	11387.100	3.72850	INFINITY	0.00000
5	410.000	4815.674	11378.773	3.72850	INFINITY	0.00000
5	420.000	4810.136	11370.447	3.72850	INFINITY	0.00000
5	430.000	4804.598	11362.120	3.72850	INFINITY	0.00000
5	440.000	4799.060	11353.794	3.72850	INFINITY	0.00000
5	450.000	4793.522	11345.467	3.72850	INFINITY	0.00000
5	460.000	4787.985	11337.140	3.72850	INFINITY	0.00000
5	470.000	4782.447	11328.814	3.72850	INFINITY	0.00000
5	480.000	4776.909	11320.487	3.72850	INFINITY	0.00000
5	490.000	4771.371	11312.161	3.72850	INFINITY	0.00000
5	500.000	4765.833	11303.834	3.72850	INFINITY	0.00000
5	510.000	4760.295	11295.507	3.72850	INFINITY	0.00000
TANGENT POINT-PC	511.400	4759.520	11294.342	3.72850	INFINITY	0.00000
TANGENT POINT-PC	511.400	4759.520	11294.342	3.72850	494.0	0.00000
6	520.000	4754.695	11287.223	3.74591	494.0	0.00000
6	530.000	4748.930	11279.052	3.76615	494.0	0.00000
6	540.000	4743.001	11270.999	3.78639	494.0	0.00000
6	550.000	4736.910	11263.068	3.80663	494.0	0.00000
6	560.000	4730.660	11255.263	3.82688	494.0	0.00000
6	570.000	4724.254	11247.585	3.84712	494.0	0.00000
6	580.000	4717.693	11240.038	3.86736	494.0	0.00000
6	590.000	4710.980	11232.626	3.88761	494.0	0.00000
6	600.000	4704.119	11225.351	3.90785	494.0	0.00000
6	610.000	4697.112	11218.217	3.92809	494.0	0.00000
6	620.000	4689.962	11211.226	3.94833	494.0	0.00000
6	630.000	4682.673	11204.381	3.96858	494.0	0.00000
6	640.000	4675.246	11197.685	3.98882	494.0	0.00000
6	650.000	4667.685	11191.140	4.00906	494.0	0.00000
6	660.000	4659.993	11184.750	4.02931	494.0	0.00000
6	670.000	4652.173	11178.517	4.04955	494.0	0.00000
6	680.000	4644.229	11172.444	4.06979	494.0	0.00000
6	690.000	4636.163	11166.533	4.09003	494.0	0.00000
6	700.000	4627.980	11160.786	4.11028	494.0	0.00000
6	710.000	4619.682	11155.206	4.13052	494.0	0.00000
TANGENT POINT-PRC	711.004	4618.843	11154.655	4.13255	494.0	0.00000
TANGENT POINT-PRC	711.004	4618.843	11154.655	4.13255	-500.0	0.00000
7	720.000	4611.361	11149.659	4.11456	-500.0	0.00000
7	730.000	4603.153	11143.948	4.09456	-500.0	0.00000
7	740.000	4595.060	11138.074	4.07456	-500.0	0.00000
TANGENT POINT-PT	747.238	4589.276	11133.722	4.06008	-500.0	0.00000
TANGENT POINT-PT	747.238	4589.276	11133.722	4.06008	INFINITY	0.00000
TANGENT POINT-PC	749.034	4587.849	11132.632	4.06008	INFINITY	0.00000
TANGENT POINT-PC	749.034	4587.849	11132.632	4.06008	45.0	0.00000
9	750.000	4587.075	11132.054	4.08154	45.0	0.00000
9	760.000	4578.413	11127.098	4.30377	45.0	0.00000
9	770.000	4568.872	11124.172	4.52599	45.0	0.00000
9	780.000	4558.921	11123.422	4.74821	45.0	0.00000
9	790.000	4549.049	11124.883	4.97043	45.0	0.00000
TANGENT POINT-PCC	792.537	4546.616	11125.599	5.02680	45.0	0.00000
TANGENT POINT-PCC	792.537	4546.616	11125.599	5.02680	900.0	0.00000
10	800.000	4539.528	11127.936	5.03510	900.0	0.00000
10	810.000	4530.062	11131.160	5.04621	900.0	0.00000
10	820.000	4520.633	11134.489	5.05732	900.0	0.00000
10	830.000	4511.241	11137.923	5.06843	900.0	0.00000
10	840.000	4501.887	11141.460	5.07954	900.0	0.00000
10	850.000	4492.574	11145.102	5.09065	900.0	0.00000
TANGENT POINT-PT	859.750	4483.533	11148.751	5.10149	900.0	0.00000
TANGENT POINT-PT	859.750	4483.533	11148.751	5.10149	INFINITY	0.00000
11	860.000	4483.302	11148.846	5.10149	INFINITY	0.00000
11	870.000	4474.049	11152.640	5.10149	INFINITY	0.00000
11	880.000	4464.797	11156.433	5.10149	INFINITY	0.00000
11	890.000	4455.544	11160.227	5.10149	INFINITY	0.00000
11	900.000	4446.292	11164.020	5.10149	INFINITY	0.00000
11	910.000	4437.039	11167.814	5.10149	INFINITY	0.00000
11	920.000	4427.787	11171.608	5.10149	INFINITY	0.00000
11	930.000	4418.534	11175.401	5.10149	INFINITY	0.00000
11	940.000	4409.282	11179.195	5.10149	INFINITY	0.00000
11	950.000	4400.029	11182.988	5.10149	INFINITY	0.00000

END OF ALIGNMENT -----

EXAMPLE MODEL 2  
SPECIFYING ELEMENT 8

301, 8, SX

302, CR, RD=56.87, OB=3171900, OX=4602.524, OY=11050.396, OC=3  
10

305, CO=407.2, LO=12.2, P1

302, PA, CO=391.5, LO=14.0, P2



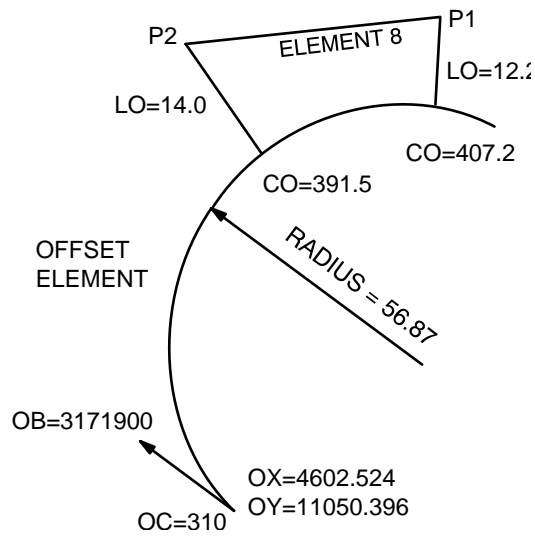


Figure 7 - 16 Example 2 - specifying element 8

Example 3

Input data:

MOSS  
HALGN, EXAMPLE MODEL3

300, IM, CE=100, NR=716200, MR=143249, CF=9031.996, SC=9031.996, LB=M003  
 301, 7, SX, X1=9347.571, Y1=2437.899, X2=9800, Y2=2494  
 301, 8, RE, RA=3000, T2  
 301, 9, LX, CU=0025133, X1=11300, Y1=2439, X2=12500, Y2=2475, L2999

Output data:

```

HALGN  EXAMPLE MODEL3
DATA ANALYSIS-----

300, IM, CE=100, NR=716200, MR=143249, CF=9031.996, SC=9031.996, LB=M003
301, 7, SX, X1=9347.571, Y1=2437.899, X2=9800, Y2=2494
301, 8, RE, RA=3000, T2
301, 9, LX, CU=0025133, X1=11300, Y1=2439, X2=12500, Y2=2475, L2999
999
TRANSITION DATA-----

DESIGN VALUE INPUT          716200.000
MINIMUM DESIGN VALUE INPUT  143249.000
DESIGN SPEED ADOPTED        61.002
NORMAL RL ADOPTED           716200.000
MINIMUM RL ADOPTED         143249.000

ELEMENT DATA-----
--
EL TYPE  XO      YO      XP      YP      XQ      YQ      WCB- DMS  RADIUS  L-TRANS  T-TRANS
AS
7 FIX S   0.000    0.000  9347.571  2437.899  9800.000  2494.000  82 55 53.1  INFINITY 0  0.000 0  0.000
8 FRE R   0.000    0.000    0.000    0.000    0.000    0.000    0 0 0.0  3000.000 0  0.000 2  0.000
9 FIX L 11842.668  4368.056 11300.000  2439.000 12500.000  2475.000  0 0 0.0  2003.933 2  0.000 0  0.000
SECONDARY ANALYSIS-----

SOLUTION  2  FOR ELEMENT      8 IS AT          14375.84160      38.42652
SOLUTION  1  USED FOR ELEMENT  8
ELEMENT SUMMARY-----
    
```

	-CHAINAGE	-X-	-Y-	-WCB-RADI-	-RADIUS-	-LENGTH-	EL
START	9031.996	9347.57100	2437.89900	1.44743			
END	9764.521	10074.52827	2528.04139	1.44743			
					INFINITY	732.525	7
START	9764.521	10074.52827	2528.04139	1.44743			
END	10684.838	10990.82822	2500.52909	1.75420			
CENTRE		10443.69963	-449.15738		3000.000	920.317	8
START	11280.969	11574.90929	2382.09250	1.70481			
END	12219.261	12500.00000	2475.00000	1.23659			
CENTRE		11842.66831	4368.05622		-2003.933	938.292	9

TRANSITION SUMMARY-----

	-CHAINAGE-	-SHIFT-	-C-VALUE-	-RL VALUE-		-LENGTH-	EL
TRAIL	10684.838	0.792	119.360	716200.000		238.733	8
LEAD	11280.969	2.655	178.651	716200.000		357.397	9
ORIGIN (X,Y,CHAIN,WCB-RADI)			11224.30391	2450.78291	10923.572	1.79399	

INITIAL DATA -----

LABEL	=	M003
START CHAINAGE	=	9031.996
FINISH CHAINAGE	=	12219.261
CHAINAGE OF FIRST POINT	=	9031.996
CHAINAGE INTERVAL-ELEMENTS	=	100.0
CHAINAGE INTERVAL-TRANSITIONS	=	100.0
TOLERANCE	=	0.500
UNITS	=	IMPERIAL
DESIGN SPEED	=	61.002
NORMAL RL VALUE	=	716200.000
MINIMUM RL VALUE	=	143249.000
MINIMUM DESIGN RADIUS	=	-999999.9
LOCALISED EASTING	=	0.000
LOCALISED NORTHING	=	0.000
NO OF SPECIAL CHAINAGES	=	0
NO OF SPECIAL CHAINAGE INTERVALS	=	0

ALIGNMENT DETAILS -----

ELEMENT	CHAINAGE	C O O R D I N A T E S		BEARING	RADIUS OF	RATE OF CHANGE
		-X-	-Y-	-RADIANS-	CURVATURE	LATERAL ACCEL.
TANGENT POINT-PB	9031.996	9347.571	2437.899	1.44743	INFINITY	0.00000
7	9100.000	9415.058	2446.267	1.44743	INFINITY	0.00000
7	9200.000	9514.298	2458.573	1.44743	INFINITY	0.00000
7	9300.000	9613.538	2470.879	1.44743	INFINITY	0.00000
7	9400.000	9712.778	2483.185	1.44743	INFINITY	0.00000
7	9500.000	9812.018	2495.490	1.44743	INFINITY	0.00000
7	9600.000	9911.258	2507.796	1.44743	INFINITY	0.00000
7	9700.000	10010.498	2520.102	1.44743	INFINITY	0.00000
TANGENT POINT-PC	9764.521	10074.528	2528.041	1.44743	INFINITY	0.00000
TANGENT POINT-PC	9764.521	10074.528	2528.041	1.44743	3000.0	0.00000
8	9800.000	10109.763	2532.199	1.45925	3000.0	0.00000
8	9900.000	10209.308	2541.672	1.49259	3000.0	0.00000
8	10000.000	10309.115	2547.822	1.52592	3000.0	0.00000
8	10100.000	10409.070	2550.643	1.55925	3000.0	0.00000
8	10200.000	10509.064	2550.130	1.59259	3000.0	0.00000
8	10300.000	10608.986	2546.286	1.62592	3000.0	0.00000
8	10400.000	10708.723	2539.113	1.65925	3000.0	0.00000
8	10500.000	10808.167	2528.621	1.69259	3000.0	0.00000
8	10600.000	10907.205	2514.820	1.72592	3000.0	0.00000
TANGENT POINT-CS	10684.838	10990.828	2500.529	1.75420	3000.0	0.00000
T	10700.000	11005.729	2497.727	1.75909	3203.4	1.00000
T	10800.000	11103.702	2477.706	1.78333	5795.8	1.00000
T	10900.000	11201.316	2455.997	1.79360	30384.1	1.00000
TRANS. ORIGIN-SS	10923.572	11224.304	2450.783	1.79399	INFINITY	1.00000
L	11000.000	11298.860	2433.967	1.78991	-9370.9	-1.00000
L	11100.000	11396.631	2412.980	1.77226	-4059.4	-1.00000
L	11200.000	11494.887	2394.407	1.74064	-2590.9	-1.00000
TANGENT POINT-SC	11280.969	11574.909	2382.092	1.70481	-2003.9	0.00000
9	11300.000	11593.782	2379.639	1.69532	-2003.9	0.00000
9	11400.000	11693.276	2369.700	1.64542	-2003.9	0.00000
9	11500.000	11793.142	2364.735	1.59551	-2003.9	0.00000
9	11600.000	11893.132	2364.759	1.54561	-2003.9	0.00000
9	11700.000	11992.996	2369.770	1.49571	-2003.9	0.00000
9	11800.000	12092.486	2379.756	1.44581	-2003.9	0.00000
9	11900.000	12191.353	2394.692	1.39591	-2003.9	0.00000
9	12000.000	12289.353	2414.542	1.34600	-2003.9	0.00000
9	12100.000	12386.241	2439.255	1.29610	-2003.9	0.00000
9	12200.000	12481.775	2468.770	1.24620	-2003.9	0.00000
TANGENT POINT-PA	12219.261	12500.000	2475.000	1.23659	-2003.9	0.00000

END OF ALIGNMENT -----

## Major option VCUSP

This major option permits the design of the vertical alignment of highways. The alignment consists of cubic curves, and where desired fixed elements (either straight or circular arcs). The technique is design orientated because the alignment passes through defined location points and can be visually displayed on the road long section by use of mechanical aids.

Spline curve fitting techniques have been developed to allow the superimposing of a continuous alignment through a series of specified location points and the resulting alignment is of polynomial form and wholly transitional.

The spline technique is to fit a separate curve between each successive pair of location points on the alignment in such a manner so as to allow continuity of grade and curvature between adjacent curves. The minimum order of equation which permits such continuity is a cubic and this form of polynomial is used between the location points. The result is a smooth transitional alignment between desired end constraints and passing through all the location points.

A great advantage inherent in the technique is that the alignment can be visually presented by mechanical aids during the design evaluation and in fact this was the origin of the spline technique. Boxwood splines were used as a draughting aid to produce smooth curves through a series of fixed points. For alignment preparation either piano wire or coiled wire may be used and location 'bridges' permit the desired location. The wire produces a continuous curve of complex function but the section between each pair of location points is virtually a cubic and its approximation is used in the cubic spline evaluation of the alignment.

The advantages of immediately displaying an alignment are obvious particularly in restricted situations because the route of the alignment can always be mathematically defined. In unrestricted regions the location points will be nominal for fixing the alignment but where there are more constraints than can be satisfied, without introducing unsatisfactory reversal of curvature, the designer can utilise the mechanical spline to produce an optimum solution which can then be specified for final calculation.

The spline technique will always produce a satisfactory alignment and the advantages of introducing fixed straights and curves are simply for reproducing end conditions and in the case of intermediate elements should only be used where the constraints particular to the physical situation require them. It is not intended that the program should be able to simulate a conventional alignment which is performed adequately by major options VERAT and VALGN. In fact it should be noted that the fixed curves in VCUSP are circular whereas in VERAT and VALGN the curves are parabolae.

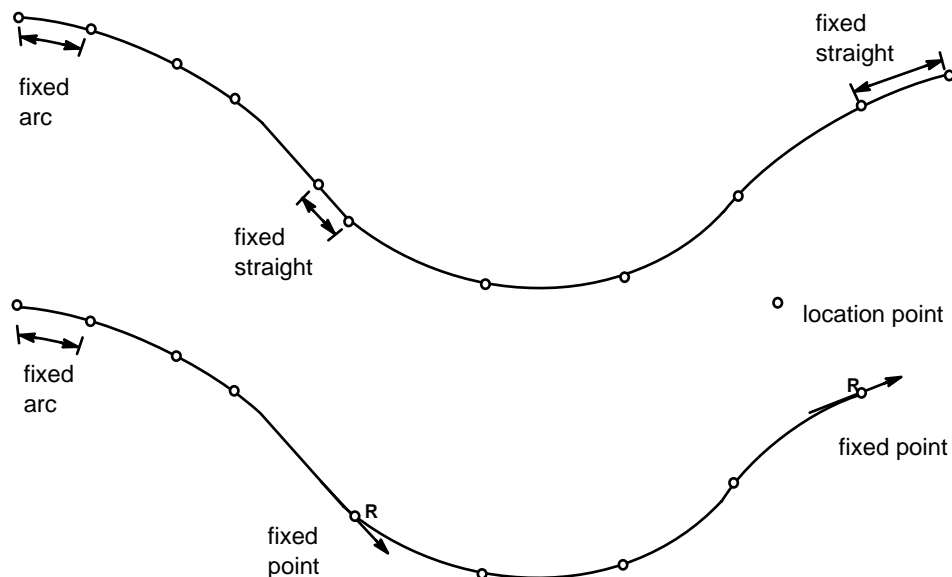
## Theory

The option reads in the chainage and level of the location points defining the path of the desired alignment plus the initial and final gradients. The cubic equation fitted between each pair of location points is of the form:-

$$y = a + bx + cx^2 + dx^3$$

and a series of equations is formulated for each of the location points to define the continuity constraints of gradient and curvature between the adjacent cubic curves. These are the spline conditions and the equations are solved by a cubic spline interpolation method to give the end constraints for each cubic curve from which the coefficients a, b, c and d are determined. When these coefficients are evaluated for each curve the option proceeds to determine the actual levels of the previously stored master alignment points.

The basic spline alignment only allows the grades to be defined at the ends of the alignment. The radius determined at these points is dependant on the relative positions of the adjacent location points. Although these points may be carefully selected it is very difficult to produce exactly the desired radius. This problem has been overcome by extending the technique to permit fixed straight or circular elements or points to be specified at the start and finish of the alignment and within the alignment. In these instances the problem resolves itself into a series of spline applications between each of the fixity conditions.



**Figure 7 - 17 Spline and fixed elements**

The inclusion of fixed elements and points introduces a further problem to the solution because the number of alignment constraints are greater than can be resolved by the cubic function as previously described. This curve requires the specification of the end coordinates and bearings of the

element and the introduction of a radius requires special treatment. The technique adopted is to introduce an additional location point midway between the fixed element or point and the adjacent location point, which is free to move, until the required conditions are satisfied. This extra point is introduced into the parametric solution without specifying actual easting and northing coordinates and the equality of constraints is maintained.

The physical spline should always be used to ensure adequate location points are defined to produce both a desirable line and end continuity. The adjustment technique ensures mathematically perfect merging of the spline and fixed elements or points.

Application of fixed elements and fixed end points

The introduction of fixed elements is intended to introduce greater flexibility to the spline alignment technique. It is not intended that the program should be able to simulate a conventional alignment of straights. This is performed adequately by major options VERAT and VALGN and the three options should be considered complimentary.

The fixed points are specified in the following manner:

**STRAIGHT** A value of 999999.9 is specified for the radius at both the end location points.

**CIRCULAR ARC** The radius is specified at both the end location points.

The fixed elements are specified in the following manner:

**STRAIGHT** The required bearing and a radius of 999999.9 is specified.

**CIRCULAR ARC** The required grade and radius are specified.

If the radius is omitted at an end fixed point then it is considered as a simple spline. This facility is not permitted at an intermediate fixed point.

The fixed elements are used as follows:

- fixed element - spline or splines - fixed element.

The element is specified as previously described and an additional location point is inserted on the first specified spline curve as shown.

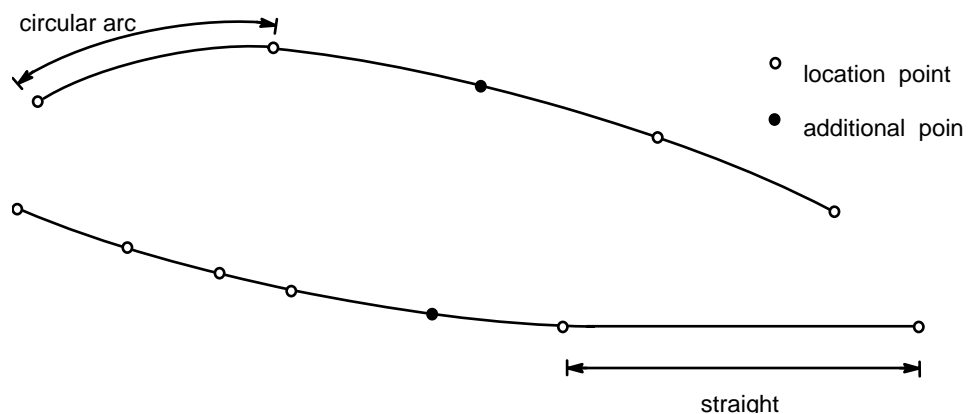
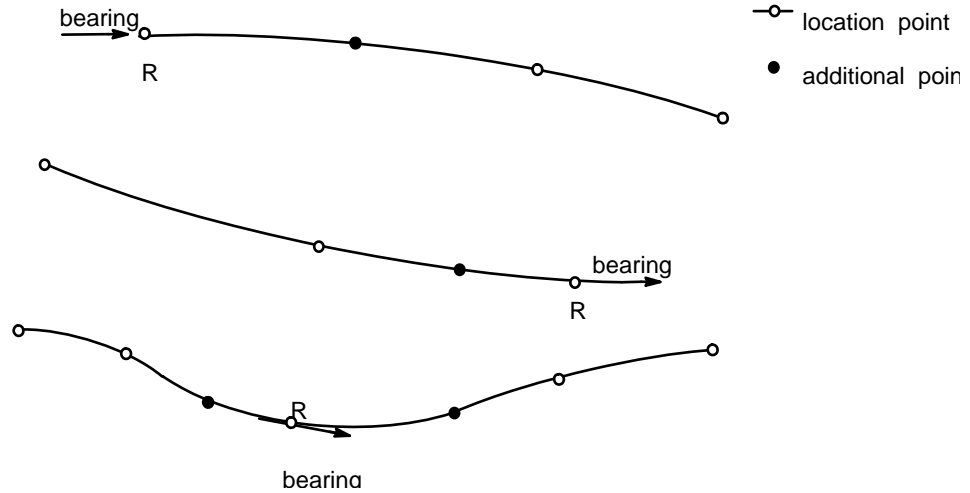


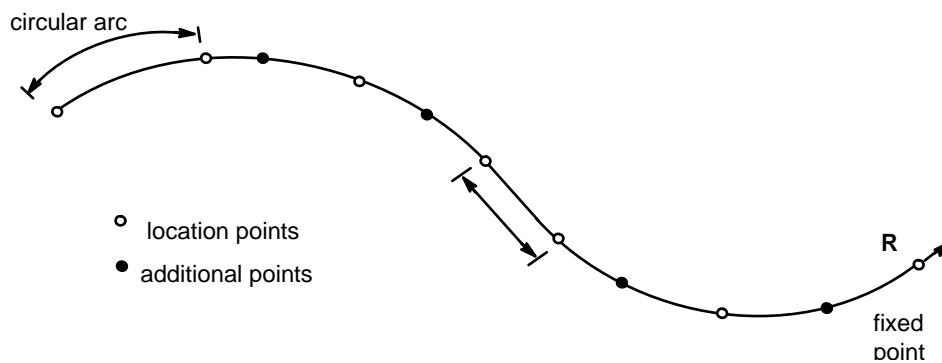
Figure 7 - 18 Use of fixed elements

- fixed point - spline or splines - fixed point.  
This is a special case of the former type and can apply at the start and finish or at any intermediate point within the alignment.



**Figure 7 - 19 Use of fixed elements - special case**

Fixed elements and points may be specified anywhere within the alignment as long as the intermediate splines consist of at least three specified location points, ie fixed elements and/or fixed points may not be adjacent.



**Figure 7 - 20 Additional points**

## Data preparation

A standard input data sheet is provided for this option.

Major option VCUSP

Model 1 Model containing the master alignment string.  
This option adds levels to an existing string.

**Initial data**

- \* Field 1      String label
- Field 2      Start chainage  
This must lie on the master alignment and be equal to or greater than, the first location point. If blank the start of the master alignment is assumed or the first location point chainage, whichever is the greater.  
However, if the first location point is taken, this must be an existing point on the master alignment.
- Field 3      End chainage  
This must lie on the master alignment and be less than or equal to the last location point. If blank the end of the master alignment is assumed or the last location point chainage, whichever is the smaller.  
However, if the last location point is taken, this must be an existing point on the master alignment.
- \* Field 9      Number of location points to follow (maximum 500)

**Location point details**

- \* Field 1      Chainage
- \* Field 2      Level
- Field 3      Percentage gradient, if required
- Field 4      Radius of curvature, -ve hog curve, +ve sag curve.  
If the radius is omitted at the start or end location point a simple spline solution is determined.

**Output**

The chainage, level, gradient and vertical radius of curvature are printed for all the chainages stored previously in the master alignment string which are within the range of the specified start and end chainages. If the start and end chainages lie within the range of the location points then the preceding and following location point details are printed but not written to the master alignment file. If a location point chainage is not present on the master alignment, details of the point are printed, but not stored.

The sequence number of the cubic curve to which details refer is also printed for each chainage point and if a straight grade has been requested the radius is replaced by 999999.9.

**Interpretation of results**

The radius of curvature is determined at each of the chainage points and must be checked for compliance with the design standards. The sign convention is positive for sag curves and negative for summit curves and the points of contraflexure are indicated by the change of sign of the radius. The engineer must decide if the frequency of these points of contraflexure, and associated curvature, produce an acceptable horizontal alignment. This may indicate a more refined choice of location points is necessary to

produce a smoother alignment which may be verified by the use of design aids.

Example

The vertical alignment is specified by five location points, an initial gradient leading from a straight grade and tying into a straight grade between chainages 2100.0 and 3600.0. Levels are only required over the chainage range 250.0 to 2400 on master alignment MAST. The input data and printout are illustrated below.

```
VCUSP, TEMP
MAST, 250, 2400, 9=5
250, 47.1, 0.04
880, 43.25
1500, 49.65
2100, 50.05, , 999999.9
3600, 47.04, , 999999.9
999
```

```
INITIAL DATA -----
LABEL = MAST
START CHAINAGE = 250.000
FINISH CHAINAGE = 2400.000
NO OF GIVEN LOCATION POINTS = 5
NO OF CALCULATED LOCATION POINTS = 1
W430 START CH. AFTER START OF ALIGNMENT
W431 FINISH CH. BEFORE END OF ALIGNMENT
```

```
ALIGNMENT DETAILS -----
```

	ELEMENT	-CHAINAGE-	--LEVEL--	GRADE*100	V. RADIUS	
	LOCATION POINT	1	250.000	47.100	0.040	-15511.5
		1	260.000	47.101	-0.023	-16030.0
		1	520.000	45.542	-0.940	-122619.5
etc						
		1	860.000	43.240	-0.012	15934.9
		1	870.000	43.242	0.052	15422.4
	LOCATION POINT	2	880.000	43.250	0.117	14941.8
		2	890.000	43.265	0.183	15357.3
		2	900.000	43.287	0.248	15796.5
etc						
		2	1480.000	49.484	0.874	-23983.7
		2	1490.000	49.569	0.832	-22985.5
	LOCATION POINT	3	1500.000	49.650	0.787	-22067.1
		3	1510.000	49.726	0.742	-22650.8
		3	1520.000	49.799	0.699	-23266.3
etc						
		3	1780.000	50.505	-0.024	-79330.0
		3	1790.000	50.502	-0.036	-87434.1
	ADDED LOCATION POINT	4	1800.000	50.498	-0.047	-97382.5
		4	1810.000	50.493	-0.057	-100740.5
		4	1820.000	50.487	-0.066	-104338.4
etc						
		4	2080.000	50.090	-0.200	INFINITY
		4	2090.000	50.070	-0.200	INFINITY
	LOCATION POINT	5	2100.000	50.050	-0.201	INFINITY
		5	2110.000	50.030	-0.201	INFINITY
		5	2120.000	50.010	-0.201	INFINITY
etc						
		5	2390.000	49.468	-0.201	INFINITY
		5	2400.000	49.448	-0.201	INFINITY
	LOCATION POINT	6	3600.000	47.040	-0.201	INFINITY

```
END OF ALIGNMENT -----
```

```
1
DATE : 29/ 4/91 TIME : 11/38/ 0
MOSS
```

PAGE : 20

W201 END OF INPUT DATA FILE REACHED

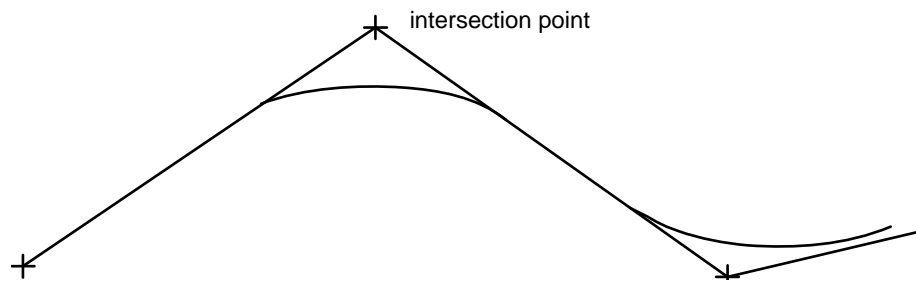
FINI



## Major option VERAT

Major option VERAT permits the design of highway vertical alignments specified by a series of intersecting straights and associated curves. Levels may be calculated for each of the chainage points along the whole length or along part of a master alignment. The master alignment string must have been created prior to this option.

The vertical alignment is specified as a series of points defining the intersections of the longitudinal gradients together with a parameter to describe the curve which links the grades.



**Figure 7 - 21 Vertical alignment - intersection points**

These intersection points are points of defined chainage and level lying at the point of intersection of two consecutive grades though the first and last intersection point need only lie on their respective grades.

The curve used in the analysis is a vertical parabola of the form:-

$$y = ax^2 + bx + c$$

and is calculated in accordance with either the specified curve length or the curve M value, which is the rate of change of percentage gradient per 100 units. If neither parameter is given the curve is based on the default values as given in the initial data by either the minimum curve length or maximum M value. Although standard practice in the UK is to define vertical curves in terms of their M value, some countries standardise on the actual radius at the parabola vertex: VERAT allows for this.

If the curve length or M value for a curve is individually specified but differs from the initial data it is still used but a warning is printed.

If compound curves are specified so that there is no intervening length of straight the curves are best defined by curve length to avoid overlap.

### Curve properties

The curve used in the analysis is a vertical parabola which is specified by its M value. This is the rate of change of percentage gradient per 100 units and is used as a measure of the curvature of a curve because it has a suitable range of numeric values. The following equations define the properties of the parabolic curve.

$$y=ax^2+bx+c$$

where:

$x$  = chainage

$y$  = level

The real gradient is given by:

$$\frac{dy}{dx}=2ax+b$$

so the curvature is given by:

$$\frac{1}{R}=\frac{d^2y}{dx^2}=2a=\frac{g_2-g_1}{L}$$

where:

$g_1, g_2$  = Actual gradients at two points on the curve

$L$  = Distance between the two points

By definition above:

$$M=100 \left( \frac{G_2-G_1}{L} \right)$$

where:

$G_1, G_2$  = Percentage gradients at two points on the curve

$L$  = Distance between the two points

so, substituting:

$$M=100 \left( \frac{100g_2-100g_1}{L} \right)$$

$$=100002a$$

But because  $a=\frac{1}{2R}$  :

$$M=\frac{10000}{R}$$

The M value for a straight is zero.

Within MOSS curves of radius equal to or greater than 999999.0 are assumed to be straight, and this is true of both horizontal and vertical curves. Consequently an M value of less than 0.01 will be interpreted as a straight. It is also possible for a curve defined by (chainage, level, grade) or (chainage, level) to have a derived M value of less than 0.01 which would again be interpreted as a straight. As a result levels apparently accepted by the system could be varied to give the smooth alignment. **Users including 'flat' curves in vertical alignments should check both the alignment and curve analyses thoroughly.** Alternatively users may wish to use VCUSP.

Where standard practice is to use the Radius rather than the M value this will be interpreted according to the associated parameter file setting. It can also be set as such on the initial data record.

The sign convention for curvature is that hog curves are negative and sag curves positive.

The sign convention for gradients is that in the direction of increasing chainage a dipping gradient is negative and a rising gradient is positive.

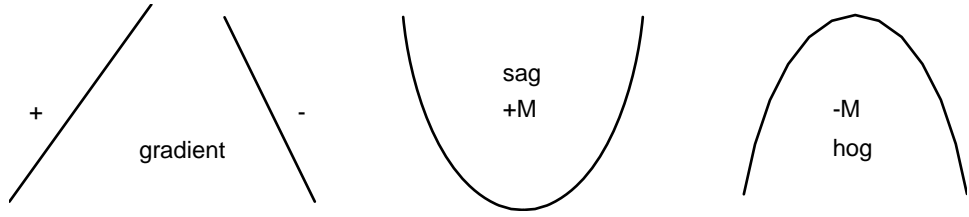


Figure 7 - 22 Gradients - sign conventions

## Data preparation

A standard input data sheet is provided for this option.

Major option VERAT

- Model 1 Model containing the master alignment string. This option adds levels to an existing string.
- Model 2 Model containing the geometry string. If omitted no geometry string will be updated. If the master alignment and the geometry string are in the same model, code the second model name the same as the first.

### Initial data

- \* Field 1 Existing master alignment string label.
- Field 2 Start chainage  
This must lie on the master alignment. If left blank the start of the master alignment is assumed.
- Field 3 End chainage  
This must lie on the master alignment. If left blank the end of the master alignment is assumed.
- Field 4 Minimum curve length - This value will be used if for a curve neither the curve length nor the M value is defined. Warnings will also be given if any curve has a length smaller than this value.
- Field 5 Maximum M value - Hog
- Field 6 Maximum M value - Sag  
These values will be used if for any curve neither the curve length, nor the M value, nor the minimum curve length is defined. Warnings will also be given if any curve has an M value greater than this value. If left blank a default value of 10.0 is assumed in both instances.
- \* Field 7 Number of intersection points (maximum 500).
- Field 8 Definition of curvature (+1 indicates M value: +2 indicates Radius).  
By default the definition is set on the parameter file at system installation.

### Element data

First intersection point

- \* Field 1 Chainage
- \* Field 2 Level

Intermediate intersection point

- \* Field 1 Chainage of intersection point opposite curve under consideration

- \* Field 2      Level
- Field 3      Curve length (optional)
- Field 4      M value (optional)

Where neither the curve length nor the M value is defined, the default values as specified in the initial data are taken in the following priority:

- if the maximum curve length is defined this is taken
- if only the maximum M value is defined this is taken (dependent on the curve being hog or sag the program chooses the relevant M value).

Last intersection

- \* Field 1      Chainage
- \* Field 2      Level

### **Final record**

The data should be terminated by a 999 minor option.

◇ *Comments and blank lines cannot be included within the VERAT data.*

## **Output**

The alignment data is analysed and the summary of the vertical curve data includes details of the tangent points and vertices.

This is followed by printed details of the chainage, level, percentage gradient and vertical radius of curvature for all the points stored previously in the master alignment string which are within the range of the specified start and end points. The level of each point on the master alignment string is updated. Details of each tangent point are printed but unless the chainage point exists on the string the level is not stored.

The sequence number of each element is printed for each chainage point and if the element is a straight the radius will be shown as infinity.

It should be noted that the element number will not be the same as the intersection point number as each of the intermediate straight grades are themselves elements. This is true even if (as in the case of compound curves) the length of the intervening straight grade is zero.

If requested the geometry string will be updated with the vertical alignment geometry.

Example

```

INPUT  VERATEX.INP
DATE : 13OCT89  TIME : 13:23:46  PAGE : 1
MOSS

VERAT  EXAMPLEMOD2
M002  0.0      500.      4.0
      0.0      4.822
      234.700  7.212    270.0
      409.472  2.770    50.0
      460.000  3.285
      999

DATA ANALYSIS-----
                INTERSECTION POINT (VPI)
                CHAINAGE      LEVEL      CRV LENGTH      M
                0.000        4.822
                234.700      7.212
                409.472      2.770
                460.000      3.285

ALIGNMENT ANALYSIS-----
                1ST TANGENT POINT  -----VERTEX-----  2ND TANGENT POINT  ---M---  --V.RAD
CV -CHAINAGE- -LEVEL-- -CHAINAGE- -LEVEL-- -CHAINAGE- -LEVEL--
NO
1   0.0000  4.8220
2   99.7000  5.8373  176.9340  6.2305  369.7000  3.7808  -1.31849  -7584.4
3   369.7000  3.7808
4   384.4720  3.4054  420.1602  2.9519  434.4720  3.0248  7.12167  1404.2
5   434.4720  3.0248  500.0000  3.6927  0.00000  INFINITY

CURVE ANALYSIS-----
                INTERSECTION POINT  CRV LENGTH  ----M----
                (VPI)
                CHAINAGE  -LEVEL-
                0.0000  4.8220
                234.7000  7.2120  270.00000  -1.31849
                409.4720  2.7700  50.00000  7.12167
                500.0000  3.6927

INITIAL DATA -----
LABEL = M002
START CHAINAGE = 0.000
FINISH CHAINAGE = 500.000
MINIMUM CURVE LENGTH = 0.000
MAXIMUM VALUE FOR SAG = 10.000
MAXIMUM VALUE FOR HOG = -10.000
NO.OF ELEMENTS = 5
W431 FINISH CH. BEFORE END OF ALIGNMENT
ALIGNMENT DETAILS -----
                ELEMENT  -CHAINAGE-  --LEVEL--  GRADE*100  V. RADIUS
                1      0.000      4.822      1.018      INFINITY
                1      10.000      4.924      1.018      INFINITY
TANGENT POINT-VPC  2      99.700      5.837      1.018      -7584.4
                2      100.000      5.840      1.014      -7584.4
                2      107.562      5.913      0.915      -7584.4
                2      110.000      5.935      0.883      -7584.4
                2      120.000      6.017      0.751      -7584.4
                2      130.000      6.085      0.619      -7584.4
                2      140.000      6.141      0.487      -7584.4
                2      150.000      6.183      0.355      -7584.4
                2      160.000      6.212      0.223      -7584.4
                2      170.000      6.227      0.091      -7584.4
                2      173.672      6.230      0.043      -7584.4
                HIGH POINT  2      176.934      6.231      0.000      -7584.4
                2      180.000      6.230      -0.040      -7584.4
                2      190.000      6.219      -0.172      -7584.4
                2      200.000      6.195      -0.304      -7584.4
                2      214.286      6.139      -0.492      -7584.4
                2      228.571      6.055      -0.681      -7584.4
                2      242.857      5.944      -0.869      -7584.4
                2      257.143      5.806      -1.058      -7584.4
                2      271.429      5.642      -1.246      -7584.4
                2      285.714      5.450      -1.434      -7584.4
                2      300.000      5.232      -1.623      -7584.4
                2      314.286      4.987      -1.811      -7584.4
                2      328.571      4.715      -1.999      -7584.4
                2      342.857      4.416      -2.188      -7584.4
                2      357.143      4.090      -2.376      -7584.4
TANGENT POINT-VPT  3      369.700      3.781      -2.542      INFINITY
                3      371.429      3.737      -2.542      INFINITY
TANGENT POINT-VPC  4      384.472      3.405      -2.542      1404.2
                4      385.714      3.374      -2.453      1404.2
                4      400.000      3.097      -1.436      1404.2
                4      414.286      2.964      -0.418      1404.2
                LOW POINT  4      420.160      2.952      0.000      1404.2
                4      428.571      2.977      0.599      1404.2

```

```
TANGENT POINT-VPT  5      434.472      3.025      1.019      INFINITY
                   5      442.857      3.110      1.019      INFINITY
                   5      457.143      3.256      1.019      INFINITY
                   ELEMENT  -CHAINAGE-  --LEVEL--  GRADE*100  V. RADIUS
                   5      471.429      3.401      1.019      INFINITY
                   5      485.714      3.547      1.019      INFINITY
TANGENT POINT-VPI  5      500.000      3.693      1.019      INFINITY
END OF ALIGNMENT-----
W201 END OF INPUT DATA FILE REACHED
OUTPUT
TANGENT POINT-VPI  5      500.000      3.693      1.019      INFINITY
END OF ALIGNMENT -----
W201 END OF INPUT DATA FILE REACHED
```

## Major option VALGN

VALGN is a member of the Vertical Alignment group of options and may be used to calculate the levels along the whole or part of a master alignment, which must have been created prior to running this option. It is useful to have previously obtained a ground long section along the proposed horizontal alignment as this is the basic profile from which the data for creating a vertical alignment is obtained. The calculated geometry is based on vertical parabolae which is similar to option VERAT but the approach differs in that it does not use the principle of intersecting straights to locate the vertical curves. The curves themselves are drawn in the required position on the profile and specified by points lying on the curves and this simplifies the procedure.

The method dispenses with the use of tangents; each element can be curved and touches the elements on either side. This eliminates the short lengths of straight between curves which are features of the VERAT method. Straights can be used, however, as they are treated as a special type of curve. Initially the designer draws the curve of suitable radius in tangency with the first curve, passing through a chosen point further along the alignment. The designer proceeds in this way until the final alignment has been drawn, and is thereby given greater flexibility to locate the alignment within the engineering constraints because the elements may have varying degrees of fixity.

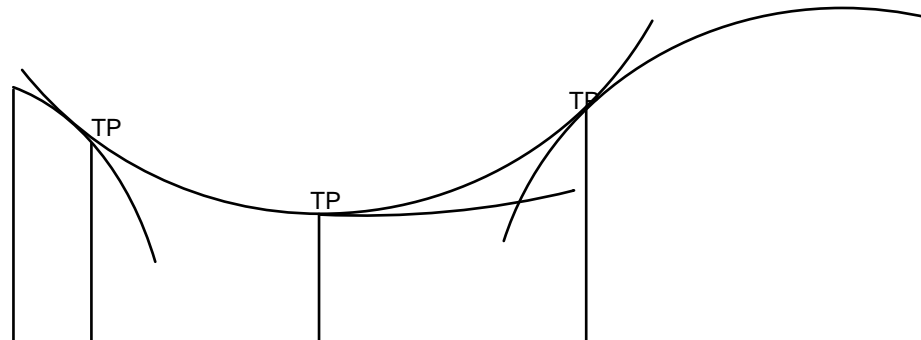


Figure 7 - 23 Transition points

### Curve fixity

The fixity of an element is measured by the extent to which the element is defined by the user and there are three degrees of fixity.

Fixed	precisely located in position
Floating	defined by two constraints allowing one degree of freedom, such as rotation about a point. The location of the curve is determined by the arrangement of the adjacent elements.



Free defined by one constraint allowing two degrees of freedom. The location is determined by the arrangement of the adjacent elements.

**Curve specification**

The constraints needed to resolve the curves may be given in one of three ways.

Specification of a chainage and level through which the curve must pass.

Specification of a chainage with an associated grade.

Specification of the curvature of the element. This is given in terms of the M value which is the rate of change of percentage gradient per 100 units. This figure is often used for data entry because it has a suitable numeric range of values. However it is also possible to define the radius of curvature directly.

The various data combinations required in the derivation of the various types of curves are illustrated in the following table.

Element Type	M or R	Point A		Point B		Point C		
		X	Y	X	Y	X	Y	G
Fix 1.		X	X	X	X	X	X	
Fix 2.	X	X	X	X	X			
Fix 3.	X	X	X			X		X
Fix 4.		X	X	X	X	X		X
Fix 5.	X					X	X	X
Float 1.		X	X	X	X			
Float 2.	X	X	X					
Float 3.		X	X			X		X
Float 4.	X					X		X
Free 1.	X							
Free 2.		X	X					
Free 3.						X		X

**Analysis technique**

The option allows the location of the curves in both a forward and backward direction. The sequence of the different types of elements must be such that

the progressive fixing of the elements allows the location of all the floating and free curves.

The analysis is performed in the following sequence of passes through the elements:

1. starting at the first element and working towards the last, each of the fixed curves is resolved.
2. again starting at the first element and working towards the last all the floating curves which follow fixed elements are converted to fixed elements. This includes the floating elements which follow a curve that has just been fixed.
3. starting at the last element and working towards the first all the floating curves which precede fixed elements are converted to fixed elements in a similar manner to (b) above.
4. only the free curves should now remain and if the sequence of elements has been correctly defined a fixed curve should lie to either side of each free curve. Starting at the first element and working towards the last, each free curve is resolved in relation to its adjacent fixed curves. If these free curves cannot be located the element sequence is incorrect and indicated by an error message.

### Principles of Element combinations

1. There must always be at least one fixed element in alignment.
2. Neither the first nor the last element may be a free element.
3. Two adjacent elements must not both be free.
4. Between any two free elements there must be at least one fixed element.
5. Two adjacent elements cannot be identical - eg two straights together or two curves with the same M value.
6. Greater accuracy will be attained for fixed elements defined by two or more points, if those points are not close together.
7. When floating an element about a defined point greater accuracy will be achieved by situating the defined point at a maximum distance from the fixed curve to which it will relate.
8. For free and floating curves the specified points must lie on the final alignment. As the equations of the curves used are quadratic, two roots are produced, implying dual solutions to particular problems. This is illustrated below; which shows two curves which are both tangential to the main curve AB and pass through the given points x and y on the alignment. This restriction does not apply to fixed elements.

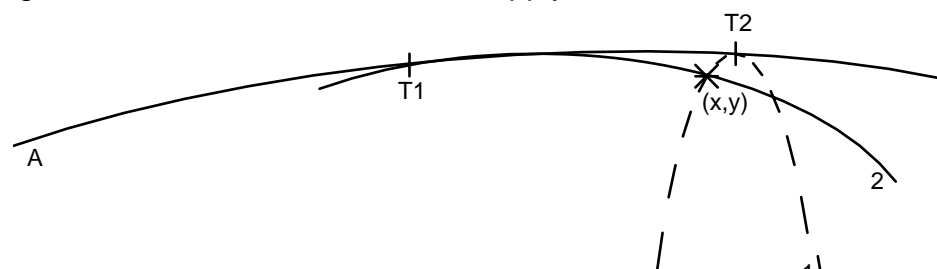


Figure 7 - 24 Example - dual solutions

Where the choice of the current solution is still in doubt (for example with free curves defined by M value) the shortest solution is preferred. In this case however, a summary of the alternative solution is given and this enables the user to define the data so that this solution is taken if preferred.

Curve properties

The curve used in the analysis is a vertical parabola which is specified by its M value. This is the rate of change of percentage gradient per 100 units and it used as a measure of the curvature of a curve because it has a convenient range of numeric values. The following equations define the properties of the parabolic curve.

$$y=ax^2+bx+c$$

where:

x = chainage

y = level

The real gradient is given by:

$$\frac{dy}{dx}=2ax+b$$

so the curvature is given by:

$$\frac{1}{R}=\frac{d^2y}{dx^2}=2a=\frac{g_2-g_1}{L}$$

where:

$g_1, g_2$  = Actual gradients at two points on the curve

L = Distance between the two points

By definition above:

$$M=100 \left( \frac{G_2-G_1}{L} \right)$$

where:

$G_1, G_2$  = Percentage gradients at two points on the curve

L = Distance between the two points

so, substituting:

$$M=100 \left( \frac{100g_2-100g_1}{L} \right)$$

$$=100002a$$

But because  $a=\frac{1}{2R}$  :

$$M=\frac{10000}{R}$$

Some users prefer to define the radius (at the vertex) directly. If the parameter file setting for this data entry is in force then the program assumes a radius is being defined rather than an M value, but other users may signify radius specification, rather than M value specification, on the initial data record. Users should note that the program interprets a radius of

zero as being a straight. Whilst this contravenes the mathematical definition it is considered more appropriate.

Within MOSS curves of radius equal to or greater than 999999.0 are assumed to be straight, and this is true of both horizontal and vertical curves. Consequently an M value of less than 0.01 will be interpreted as a straight. It is also possible for a curve defined by (chainage, level, grade) or (chainage, level) to have a derived M value of less than 0.01 which would again be interpreted as a straight. **Users including 'flat' curves in vertical alignments should check both the alignment and curve analyses thoroughly.** Alternatively users may wish to use VCUSP.

The sign convention for curvature is that hog curves are negative and sag curves positive.

The sign convention for gradients is that in the direction of increasing chainage a dipping gradient is negative and a rising gradient is positive.

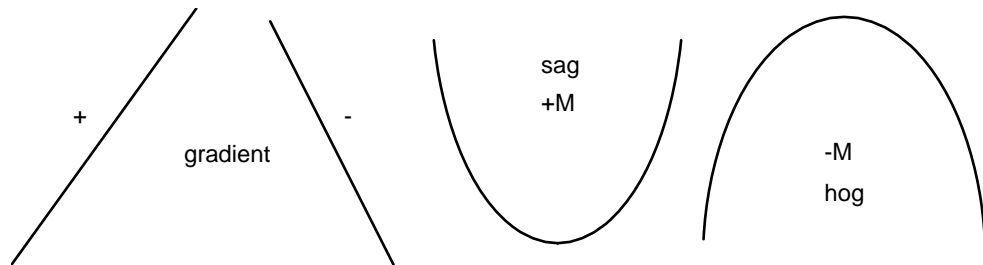


Figure 7 - 25 Gradient - sign conventions

User techniques

(i) Vertical Curve Drawing

When preparing data, the proposed longitudinal section should first be plotted in the normal way to avoid carrying inconsistencies into the system. The curves are calculated as parabolae and not circular arcs.

Geometry strings

In addition to the digital string which stores points on the alignment at regular chainage intervals, a geometry string may be stored. This string holds all the information necessary to generate the digital string at a defined interval, at a later stage. It may also be used to annotate drawings.

The interpretation of the codes in dimension 10 of the geometry string is shown below.

Vertical tangent point codes

Element Bef	Code	Element After	
None	PBC	Curve	
None	PBT	Grade	
Grade	PC	Curve	
Curve	PT	Grade	
Curve	PCC	Curve	(same sense)

Curve	PRC	Curve	(opposite sense)
Curve	PAC	None	
Grade	PAT	None	
Curve	VX	Curve	(high or low point)
Curve	VM	Curve	(middle ordinate point - see below)
Curve	VMX	Curve	(coincident high or low and middle ordinate point)
Grade	TT	Grade	(Version 9 onwards)

- ◇ *Middle ordinate points are points on the alignment perpendicularly above/below where 2 grades separated by a single vertical curve intersect.*
- ◇ *The codes PBCetc may be replaced by an alternative National code by editing the appropriate section of the parameter file.*

## Data preparation

Major option VALGN

Model 1 Model containing the master alignment string.  
This option adds levels to an existing string.

Model 2 Model containing the geometry string. If omitted the geometry string will not be updated. If the master alignment and the geometry string are in the same model, code the second model name the same as the first.

### Initial data

- \* Field 1 Existing master alignment string label:
- Field 2 Start chainage  
This must lie on the master alignment. If left blank the start of the master alignment is assumed.
- Field 3 End chainage  
This must lie on the master alignment. If left blank the end of the master alignment is assumed.
- Field 4 Maximum percentage grade  
A warning will be output if this absolute value is exceeded. If left blank a value of 10.0 is assumed.
- Field 5 Maximum M value (hog)  
A warning will be given if this value is exceeded. If left blank a value of 10.0 is assumed.
- Field 6 Maximum M value (sag)  
A warning will be given if this value is exceeded. If left blank a value of 10.0 is assumed.
- \* Field 7 Number of curves (maximum 500).

Field 8 Definition of curvature (+1 indicates M value: +2 indicates Radius). By default the definition is set on the parameter file at system installation.

**Element details**

Field 1 Curvature  
The curvature is specified as the radius or M value, depending upon the value of Field 8 in the Initial Data record. M value is defined as  $10000.0/\text{radius}$ .

This data must be entered as a decimal and a value of 0.0 indicates a straight whether the M value or radius is used.

Field 2	Chainage	)	Point A
Field 3	Level	)	
Field 4	Chainage	)	Point B
Field 5	Level	)	
Field 6	Chainage	)	Point C
Field 7	Level	)	
Field 8	Percentage Gradient	)	

The element data may be given in any combination provided the guide lines as already described are followed. There is no distinction between points A, B and C save that if any gradients are defined they are taken as being related to the chainage of point C. The program checks the combinations and decides the fixity of each element. Comprehensive diagnostics prevent abnormal or impossible situations and corrective actions should be straightforward.

A full description of the errors involved in element definition is given in Appendix 1.

**Final record**

The data should be terminated by a 999 minor option.

**Output**

The option analyses the data and diagnostic messages are given where appropriate. Any errors are analysed and from this the corrective action will usually be obvious. A comprehensive explanation of the possible causes of error is given in Appendix 1.

For those curves which have a possible alternative solution the second choice is summarised. If the alternative solution is needed the data can be redefined by either making a free curve floating, or using an alternative method of defining the curve.

The summary of the analysis includes details of the intersection points and curve vertices.

This is followed by printed details of the chainages, level, percentage gradient and vertical radius of curvature for all the chainages stored previously in the master alignment string, which are within the range of the

specified start and finish chainages. The level of each point on the master alignment string is updated. Details of each tangent point are printed but unless the chainage point exists on the string they are not stored.

The sequence number of each element is printed for each chainage point and if the element is straight the radius will be shown as infinity.

If requested the geometry string will be updated with the vertical alignment geometry.

Example

The vertical alignment is defined by a series of 5 elements. Sample input data and printout follow.

```

VALGN VALGN
M001 0.000 303.916 0.000 0.000 0.000 5 1
0.000 0.000 33.100 57.950 35.169
-7.500 135.889 35.673
0.000 167.342 34.957
5.000 232.117 34.532
0.000 303.916 35.223
999

DATA ANALYSIS-----
----M---- -POINT A----- -POINT B----- -POINT C-----
-CHAINAGE- -LEVEL- -CHAINAGE- -LEVEL- -CHAINAGE- -LEVEL- GRADIENT CURVE TYPE
0.000 0.000 33.100 57.950 35.169 1 FIXED
-7.500 135.889 35.673 2 FLOAT
0.000 167.342 34.957 3 FLOAT
5.000 232.117 34.532 4 FLOAT
0.000 303.916 35.223 5 FLOAT

ALIGNMENT ANALYSIS-----
1ST TANGENT POINT -----VERTEX----- 2ND TANGENT POINT ----M--- --V.RAD
CV CHAINAGE- -LEVEL-- CHAINAGE- -LEVEL-- CHAINAGE- -LEVEL--
NO
W455 CHAINAGE SPECIFIED ON CRV 1
IS OUTSIDE THE TANGENT POINTS
1 0.0000 33.1000 57.9374 35.1685 0.00000 INFINITY
2 57.9374 35.1685 105.5416 36.0184 135.8938 35.6729 -7.50000 -1333.3
W455 CHAINAGE SPECIFIED ON CRV 3
IS OUTSIDE THE TANGENT POINTS
3 135.8938 35.6729 167.3236 34.9574 0.00000 INFINITY
W455 CHAINAGE SPECIFIED ON CRV 4
IS OUTSIDE THE TANGENT POINTS
4 167.3236 34.9574 212.8518 34.4392 232.1000 34.5318 5.00000 2000.0
5 232.1000 34.5318 303.9161 35.2230 0.00000 INFINITY

CURVE ANALYSIS-----
INTERSECTION POINT CRV LENGTH ----M----
(VPI)
CHAINAGE -LEVEL-
0.0000 33.1000
96.9156 36.5602 77.95642 -7.50000
199.7118 34.2201 64.77643 5.00000
303.9161 35.2230

INITIAL DATA -----
LABEL = M001
START CHAINAGE = 0.000
FINISH CHAINAGE = 303.916
MAXIMUM PERCENTAGE GRADE = 10.000
MAXIMUM VALUE FOR SAG = 10.000
MAXIMUM VALUE FOR HOG = -10.000
NO.OF ELEMENTS = 5

ALIGNMENT DETAILS -----
ELEMENT -CHAINAGE- --LEVEL-- GRADE*100 V. RADIUS
1 0.000 33.100 3.570 INFINITY
1 10.000 33.457 3.570 INFINITY
1 20.000 33.814 3.570 INFINITY
1 30.000 34.171 3.570 INFINITY
1 40.000 34.528 3.570 INFINITY
1 50.000 34.885 3.570 INFINITY
TANGENT POINT-VPC 2 57.937 35.169 3.570 -1333.3
2 60.000 35.241 3.416 -1333.3
2 70.000 35.545 2.666 -1333.3
2 80.000 35.774 1.916 -1333.3
2 90.000 35.928 1.166 -1333.3
2 100.000 36.007 0.416 -1333.3

```

HIGH POINT	2	105.542	36.018	0.000	-1333.3
	2	110.000	36.011	-0.334	-1333.3
	2	120.000	35.940	-1.084	-1333.3
	2	130.000	35.794	-1.834	-1333.3
TANGENT POINT-VPT	3	135.894	35.673	-2.276	INFINITY
	3	140.000	35.579	-2.276	INFINITY
	3	150.000	35.352	-2.276	INFINITY
	3	160.000	35.124	-2.276	INFINITY
TANGENT POINT-VPC	4	167.324	34.957	-2.276	2000.0
	4	170.000	34.898	-2.143	2000.0
	4	180.000	34.709	-1.643	2000.0
	4	190.000	34.570	-1.143	2000.0
	4	200.000	34.481	-0.643	2000.0
	4	210.000	34.441	-0.143	2000.0
LOW POINT	4	212.852	34.439	0.000	2000.0
	4	220.000	34.452	0.357	2000.0
	4	230.000	34.513	0.857	2000.0
TANGENT POINT-VPT	5	232.100	34.532	0.962	INFINITY
	5	240.000	34.608	0.962	INFINITY
	5	250.000	34.704	0.962	INFINITY
	5	260.000	34.800	0.962	INFINITY
	5	270.000	34.897	0.962	INFINITY
	5	280.000	34.993	0.962	INFINITY
	5	290.000	35.089	0.962	INFINITY
	5	300.000	35.185	0.962	INFINITY
TANGENT POINT-VPI	5	303.916	35.223	0.962	INFINITY

END OF ALIGNMENT -----



## Chapter 8 Geometric design

### Geometric design

Major option DESIGN provides a set of minor options to generate or amend strings with reference to other strings according to various mathematical functions. Although the major area of application of DESIGN will be for the development of models of proposed highways, the minor options should not be considered as being restricted to highway design. The majority of DESIGN options generate three dimensional geometry. DESIGN generates strings by referring to other strings and it is possible to generate strings in a new model with reference to strings in an existing model.

The minor options available are as follows:-

- 099            Invoke the simplified design process.  
All minor options in the range 100 - 139 inclusive may be used in association with this option, with the exception of the combination options.
- 100            Constant H/constant C  
Generate or amend a section of string by constant horizontal offset and constant crossfall from an existing string.
- 101            Linear H/constant C  
Generate or amend a section of string by linearly varying horizontal offset and constant crossfall from an existing string.
- 102            Reverse H/constant C  
Generate or amend a section of string by a symmetrical reverse curve horizontal offset and constant crossfall from an existing string.
- 103            Extend/contract crossfall
- 103/104        Horiz ext of slope/offset  
Generate or amend a section of string by horizontal offsetting with automatic extension of 105/106 crossfall and a constant vertical or normal offset from an existing string or strings.
- 103/105        Intersection of 2 slopes
- 103/106        Hard shoulder design
- 107/108        Subgrade design  
Automatic derivation of subgrade strings.
- 110            Constant H/constant V  
Generate or amend a section of string by constant horizontal and vertical offset.
- 111            Linear H/constant V

	Generate or amend a section of string by linearly varying horizontal offset and constant vertical offset.
112	Reverse H/constant V Generate or amend a section of string by a symmetrical reverse curve horizontal offset and constant vertical offset.
120	Constant vertical offset Apply a constant vertical offset to a string relative to an existing string.
121	Linear vertical offset Apply a linearly varying vertical offset to a string relative to an existing string.
122	Curved vertical offset Apply a symmetrical reverse curve vertical offset to a string relative to an existing string.
123	Spline vertical offset Apply a vertical offset in the form of a splined cubic curve to a string, relative to an existing string.
125	Circular reverse curve Apply a symmetrical circular reverse curve vertical offset to a string.
130	Constant crossfall Apply a constant crossfall to a string relative to an existing string.
131	Linear crossfall Apply a linear change of crossfall to a string relative to an existing string.
132	Curved crossfall Apply a symmetrical reverse curve change of crossfall to a string relative to a reference string.
133	Superelevation Apply the theoretically calculated value of superelevation to a string relative to an existing string, or according to French Design Rules.
134	Extend crossfall (2 strings)
134/104	Extend crossfall (slope defined by 104) Amend the levels of a section of string by applying the crossfall between other strings.
135	Apply a symmetrical circular reverse curve vertical crossfall to a string.
140	Add M-string

	Generate a string in a horizontal plane
	- 141 describing a circle
	- 142 defining a straight line.
145	Create circular
	Generate a circular master alignment string between two strings.
152	Tilted plane
	Determine the levels of a string defined in a plan which lies on a tilted plane surface.

## Principles of geometric manipulation

The majority of minor options in major option DESIGN permit the creation or amendment of strings by defining simple horizontal and vertical relationships to either one or two existing strings. These strings are known as reference and subsidiary strings.

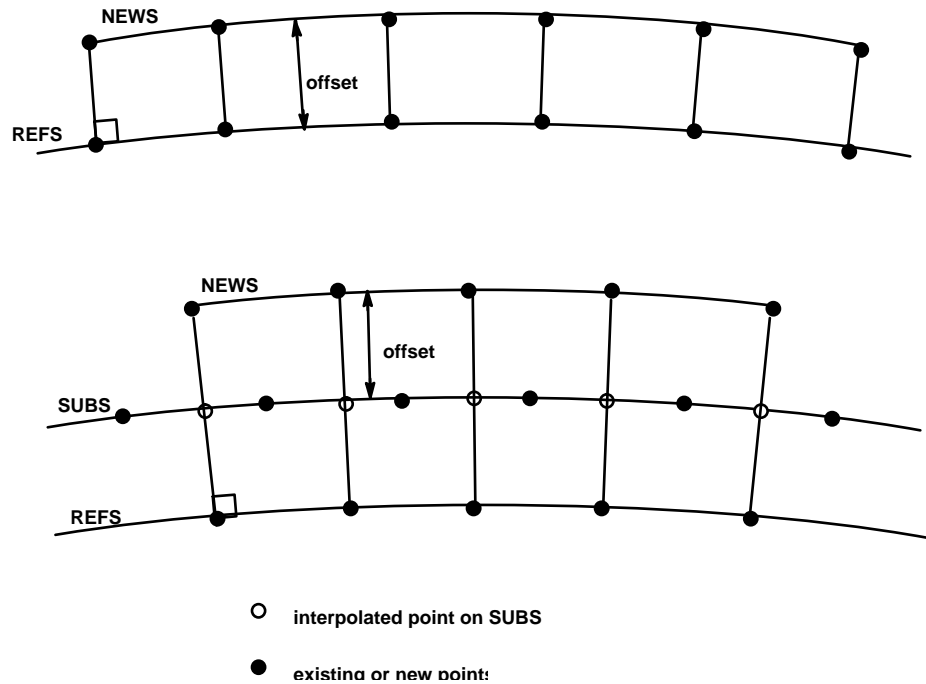
The reference string is used to:

- define the extents between which the string is to be generated or amended.
- define the direction of the normals for applying any specific offsets.
- define the extents (on chainage basis) for applying linear and reverse curve offsets (if the reference string is three dimensional a local chainage is determined between the start and end points).

The subsidiary string is used to:

- define the points from which the horizontal offsets apply.
- define the points from which the vertical offsets apply.

If only the reference string is specified it serves a dual purpose and incorporates the functions of the subsidiary string. The two situations are illustrated in the following diagrams.



**Figure 8 - 1 Geometric manipulation - principles**

The second diagram further illustrates the situation where the subsidiary string is not in sympathy with the reference string and it is necessary to interpolate points on the subsidiary string from which the offsets apply.

### String generation

The minor options may be classified as two types; horizontal options and vertical options although the horizontal options usually allow specification of a constant vertical offset. The first reference to a string by a horizontal option creates the string in the model and it can only be extended by further horizontal options. The string may be extended in either direction but there must be continuity between the previous extent of the string and the current request, otherwise the operation is considered invalid. A section of string that already exists may be modified by a horizontal option and this is considered as amending the string. All vertical options amend the string.

Strings which have discontinuities should be processed in this major option.

When creating a new string or amending an existing string the new or amended portion extends between the two normals erected at the given start and end point on the reference string. If the string exists and only one normal intersects the string it is assumed that the string is being extended. This is only allowed in the horizontal design options.

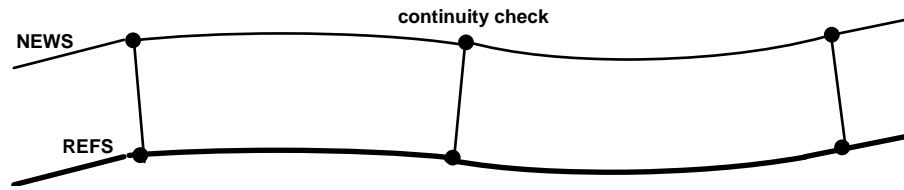


Figure 8 - 2 Example normal case - extending NEWS

If there is an overlap then the duplicate part of the existing string is replaced by the extension of the string.

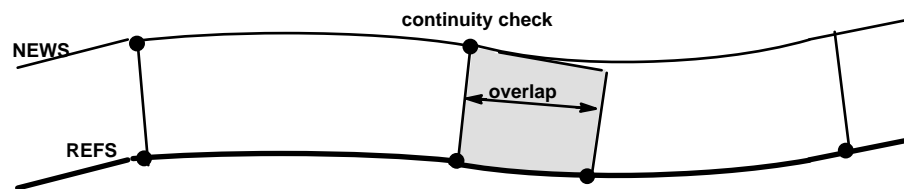


Figure 8 - 3 Example - replacement of overlap

If both normals intersect the string then the string is being amended by either a horizontal or vertical option. If neither intersection exists there is no continuity and the operation is invalid.

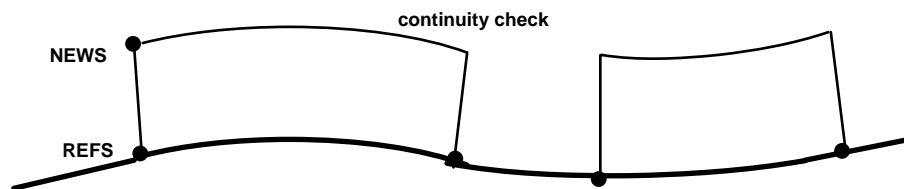


Figure 8 - 4 Example - invalid case

If a subsidiary string is involved then the normals from the reference string at the start and finish points must intersect the subsidiary string.

### Point generation

The horizontal options generate points which lie on normals erected from the reference string both at the start and end points and at the intermediate points.

For the vertical options the points already exist in plan except possibly at the extremities. In this case normals are dropped from the points to the reference string, the levels on the subsidiary string (or reference string by default) being determined by the intersection of the normal with the subsidiary string. If necessary, new points are inserted in the string at the extents of the application where the normals intersect the string. If the amended string is an alignment string the additional parameters of chainage, bearing and radius are determined for the inserted points.

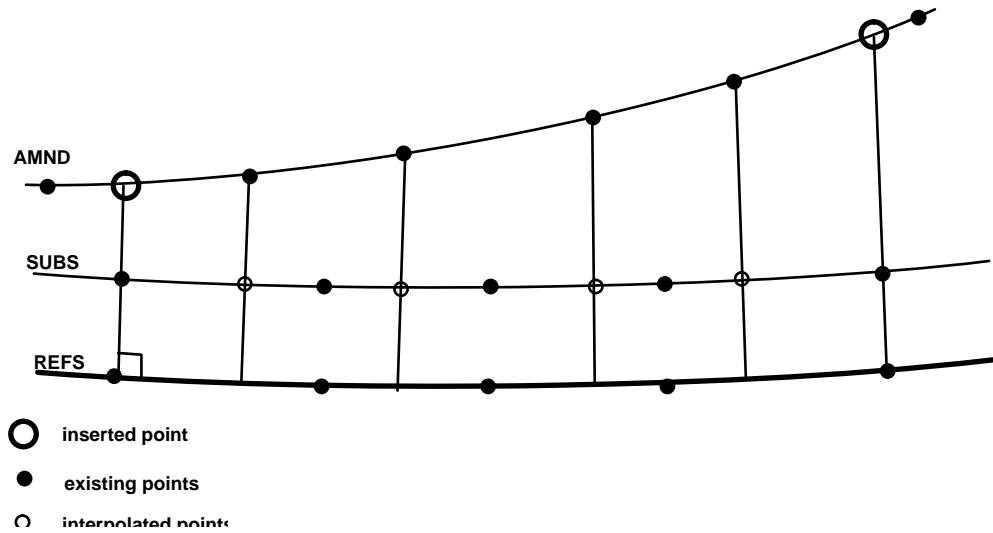


Figure 8 - 5 Example - point generation

This is a useful technique to apply levels to a 6D M-string which may or may not have levels already applied by a vertical design option.

When the horizontal options extend a string and either the horizontal or vertical options amend a string, if the offset at the start and end are different to the original offsets at those points the resultant string is as shown in the following diagram.

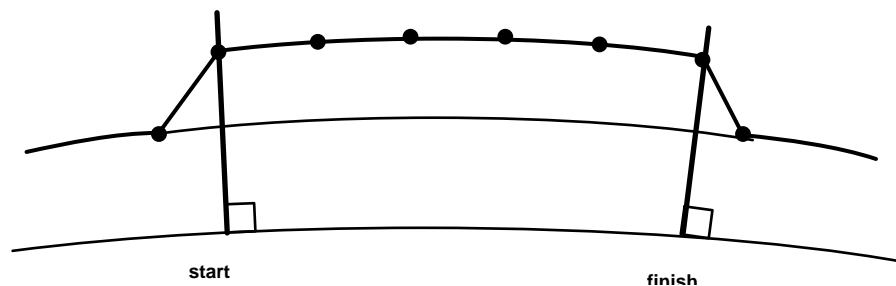
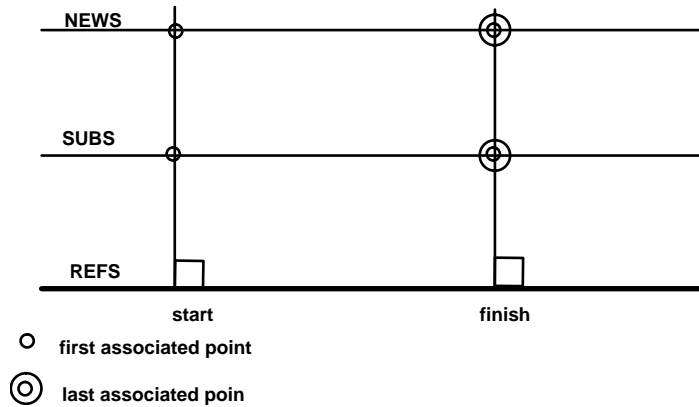


Figure 8 - 6 Example - string with amended offset

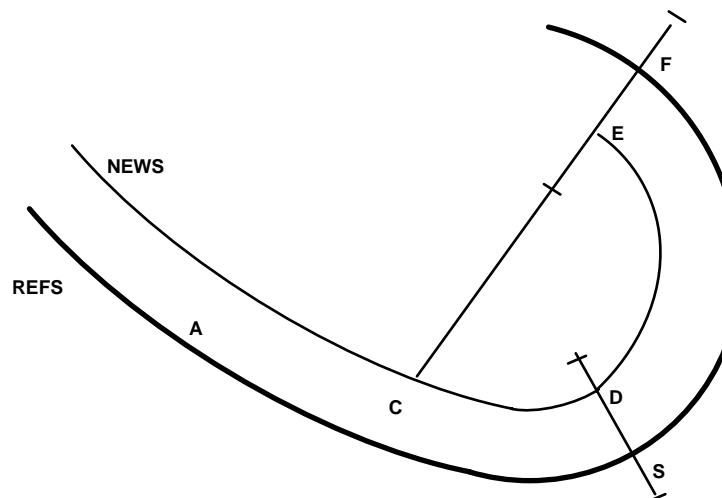
### Normals

When determining the extremities of the design application, normals are erected at the start and end points on the reference string. If the string already exists it is searched for its intersection with the normals to determine if the application is extending or amending the string. The point of intersection of the string and normal at the start of the application is referred to as the 'first associated point' and the end normal determines the 'last associated point'. These points also exist on the subsidiary string if it is specified for the application.



**Figure 8 - 7 Example - first and last associated point**

In the case of horizontal options the length of the normal is restricted to the maximum offset, defined for the application, plus ten per cent, to either side of the reference string. This is to avoid the situation when extending a string and an intersection can be found but is not the one required.



**Figure 8 - 8 Example - extension of NEWS**

The above diagram shows the string NEWS being extended from D to E. If the restriction on the length of normal was not applied the operation would be considered as amending the string between C and D and the result would be string ACED which is obviously wrong.

Where strings are being amended by the vertical options the normals which determine the extent of application, extend 100 units to either side of the reference string. If the string to be amended is more than 100 units from the reference string the offset tolerance can be increased by resetting the values with the aid of the 017 minor option (fields 7 and 10).

When searching an existing string for an intersection with the normals from the reference string there may be more than one intersection. In this situation the intersection closest to the reference string is taken unless the

reference string is cut by the normal again before cutting the existing string, see Figure 8 - 9.

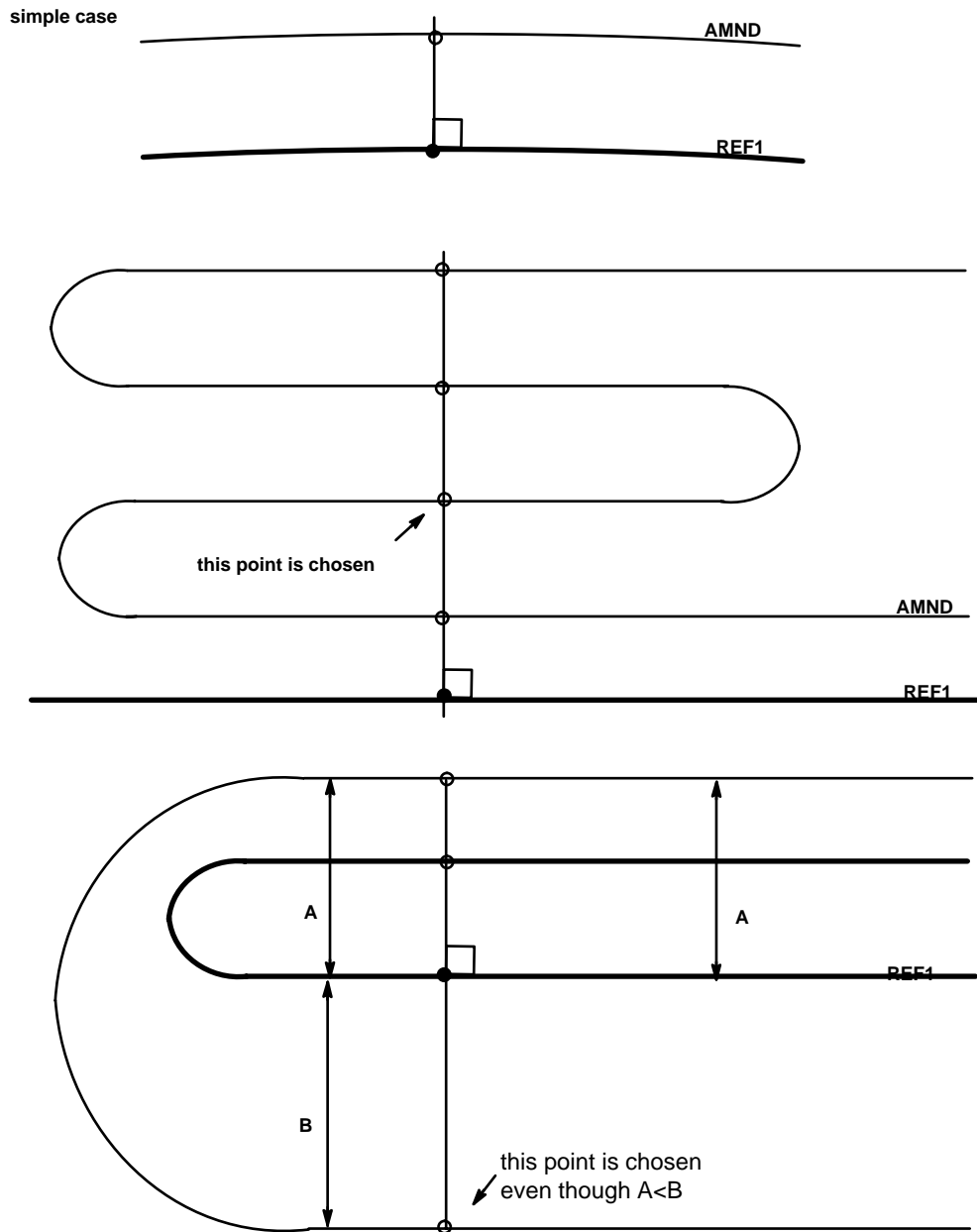


Figure 8 - 9 Example - multiple intersections by the normal

### Curve fitting

Although strings are stored a series of points, curve fitting is applied throughout the DESIGN option to maintain geometric accuracy. Curve fitting is applied to interpolate the unknown dimensions of an exact point, which provides the direction of the normal to the string at that point, and to interpolate the coordinates and dimensions of new string points. The curves which are employed in the interpolation procedures are all circular.



## Tolerances

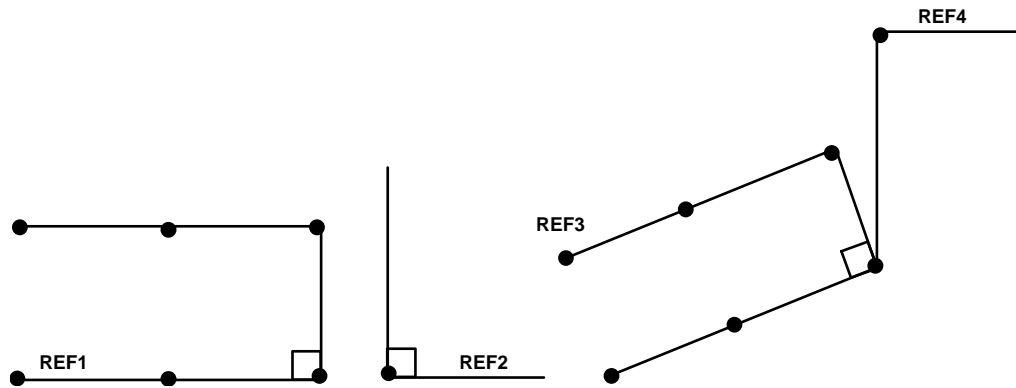
The distance tolerances used by the system are very relevant to the DESIGN option. The system is designed to work to a significance of 0.01 units and there are two basic tolerances; a general system tolerance and a location tolerance, which are used within the system to support the accuracy. The general system tolerance is internally set to 0.001 units and is used for all geometric comparison of information. The location tolerance is used for identifying points either by x and y coordinates or chainage and may be set by the user, otherwise a recommended default value of 0.010 units is assumed. This tolerance is also used when locating associated points on adjacent strings.

The principle reason for the introduction of this coarse tolerance is for use by options DESIGN and EDIT which allow the insertion of non-exact points. It ensures that any new points can be inserted within a minimum distance (the tolerance) adjacent to an existing point. The default value of 0.01 units is realistic when re-introducing and extending curvature because it ensures points are not inserted at a close interval which can cause ill-conditioning within the curve fitting routines. Unless it is essential to exactly locate a specific point it is recommended that the standard default value is accepted. The user will not normally be concerned with this level of detail which is internal to the option.

The situation where the user is involved with these tolerances is when the message - 'associated point not found' occurs. This means that a normal has not intersected a string within the system tolerance (0.001) at the start or finish as indicated. The problem must be checked for any obvious errors of string non-existence in the specified ranges, which will usually highlight the error. The remaining possibility is that the normal erected from the reference string has missed the end of the existing string by fractionally more than the system tolerance.

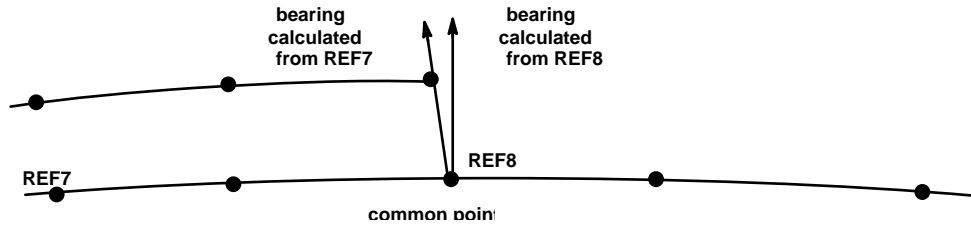
Where the reference string is continuous and strings are being designed and amended from it there will be no such problems because the curve fitting techniques are consistent. If the new string is being designed from two reference strings that have an overlapping area of interest or a common point this will most probably be the source of error.

1. Anomalies in the common point or common bearing due to design inconsistency.



**Figure 8 - 10 Anomalies common point or bearing**

2. The circular arcs are fitted at the end of each string may not give the same common bearing.

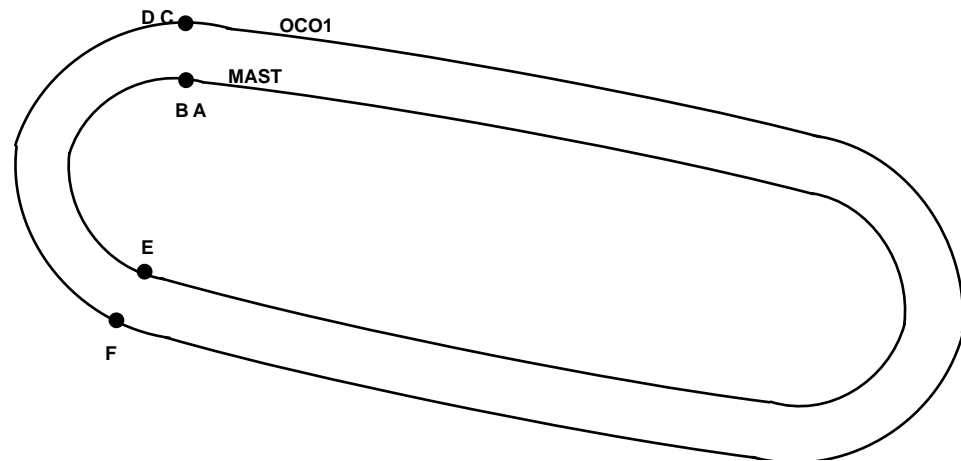


**Figure 8 - 11 Example - differing common bearing**

These situations are produced by anomalies in the geometry of the reference strings. In these situations the new feature should be designed as two strings but the minute gap in the model will remain.

### Coincident strings

If a reference string is coincident with itself either at one point or over a common part then the start or end points defining the extent of a design option may not occur within the common length if the new string is to be extended or amended. The problem is illustrated in the following diagram of a loop string where the first and last points of string MAST are coincident, (ie points A and B).



**Figure 8 - 12 Example - coincident strings**

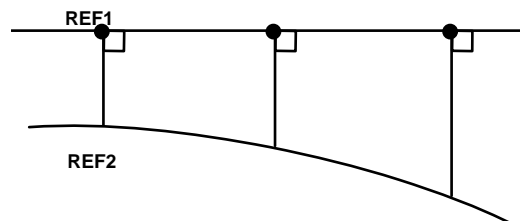
String OCO1 can only be generated from MAST by a single horizontal option, (ie from C to D where they are coincident). If an attempt were made to generate string OCO1 from C to F and then from F to D then when the erecting normals at E and B to extend the string, because B is coincident with A the option finds two intersections and considers the operation as amending from F to C (backwards) rather than extending from F to D as required. The same problem arises when trying to apply the vertical options.

The problem may be resolved by generating OCO1 up to the penultimate point on the reference string and the vertical options can be used in the normal way. The string is closed by using option 009 in EDIT. Alternatively the feature may be created as two strings.

### **Selection of reference strings for amending levels**

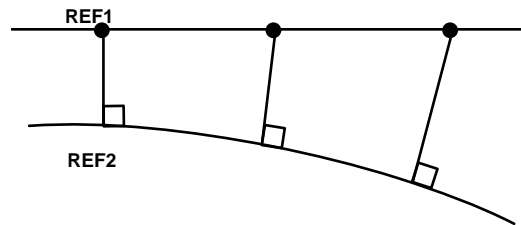
Usually the selection of reference and subsidiary strings will be obvious but in certain situations when amending the levels on a string the selection of the reference string can be used to advantage to dictate the direction of the normals. The normals define the direction and extent of the application of crossfall.

The following example illustrates the use of the string REF1 as a reference string and REF2 as an amended string.



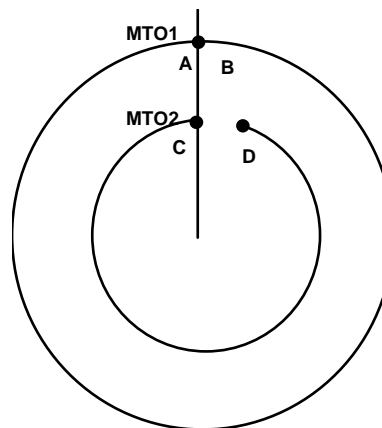
**Figure 8 - 13 Example 1 - selecting reference strings when amending levels**

Alternatively the string to be amended REF2 could also be specified as the amended string and reference string and then REF1 would become the subsidiary string from which the vertical crossfalls apply. This technique influences the direction of the normals along which the crossfall applies.



**Figure 8 - 14 Example 2 - selecting reference strings when amending levels**

The roundabout example illustrates the use of this technique to overcome the coincident point problem.

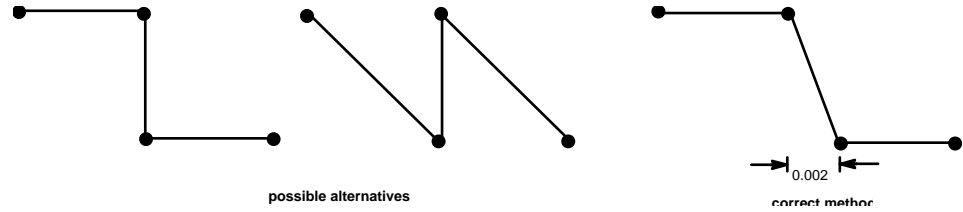


**Figure 8 - 15 Example 3 - selecting reference strings when amending levels**

The outer circle string MT01 is generated with A and B coincident and the inner circle string MT02 is generated with point C on the same radial as A but the string is not closed. It is now required to transfer the levels from MT01 to MT02. The easiest way of doing this is to specify MT02 as the reference string from which the normals are erected to establish the points on the subsidiary string MT01 from which the levels are transferred to the amended string MT02.

**Model considerations**

The surface which is presented by a series of strings is derived by assuming that adjacent string are joined to form a plane, thus when two strings are identical in plan there are two possible alternatives to the definition of a surface.



**Figure 8 - 16 Coincidence in plan**

The section option may construct the section in either of the ways shown. The situation can be avoided by introducing a minimal offset so that all planes are visible from above. See ‘correct method’ in Figure 8 - 16.

### Null levels

When alignment strings are generated by horizontal alignment options, the levels are assigned a value of -999.0 to indicate a null level. These values are overwritten by the vertical alignment options.

It is not possible to create a string simultaneously in the horizontal and vertical plane, from a subsidiary string (or reference string if no subsidiary string is specified), which has null levels in the area of interest.

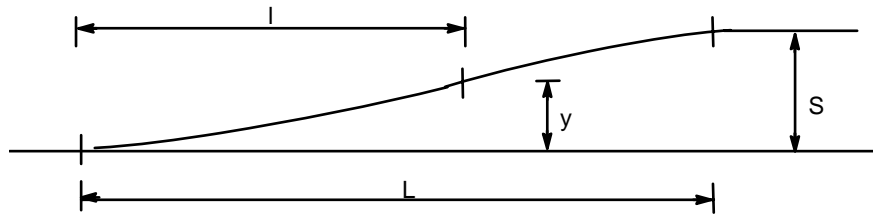
It is possible to create a string in the horizontal plane from such a string so long as no vertical relationship is specified and this string will also have null levels.

### Superelevation

Where options are used to apply superelevation, especially with the reverse curve options 122 and 132 and the 123 spline option, it is the users responsibility to ensure that the nature and location of the superelevation satisfies the design criteria, drainage and aesthetic factors. Adjustments may be made to the level with the EDIT options to accommodate these additional requirements.

### Cubic reverse curve formula

The formula used to apply reverse curves in option 102, 112, 122 and 132 is of the following form and assumes the start and end gradients are parallel to the local x axis.



where

- $y$  = offset
- $l$  = distance from start of application
- $L$  = length of application
- $S$  = maximum offset

**Figure 8 - 17 Cubic reverse curve**

### Circular reverse curve formula - vertical

The formula used to apply reverse curves in option 125 and 135 is of the following form and assumes the start and end gradients are parallel to the local x axis.

$$z=R_1-\sqrt{R_1^2-l^2}$$

$$z=S_1+m (l-L_1)$$

$$z=S_t-R_2-\sqrt{(R_2^2-(l-L)^2)}$$

$$S_t=V_2-V_1$$

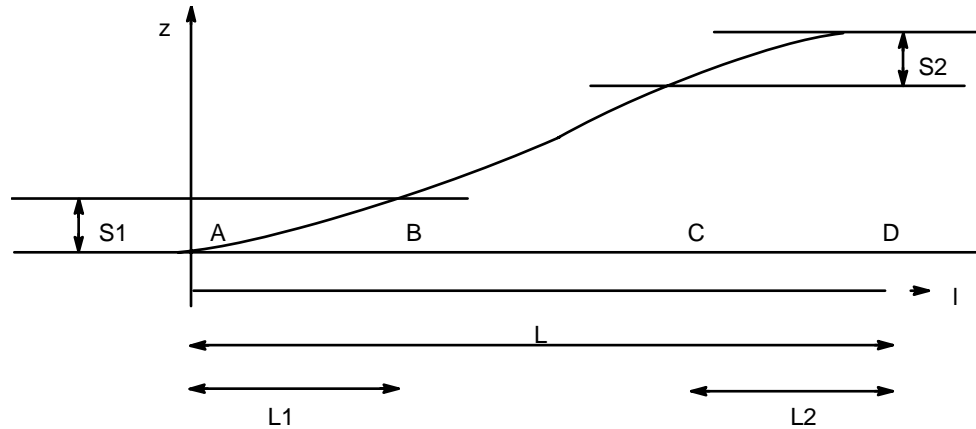
$$m=\frac{2S_t}{2L-(L_1+L_2)}$$

$$S_1=\frac{L_1S_t}{2L-(L_1+L_2)}$$

$$S_2=\frac{L_2S_t}{2L-(L_1+L_2)}$$

$$R_1=\frac{L_1^2+S_1^2}{2S_1}$$

$$R_2=\frac{L_2^2+S_2^2}{2S_2}$$



For  $A < l < B$

For  $B < l < C$

For  $C < l < D$

where:

$R1$  = radius of first circular curve

$R2$  = radius of second circular curve

$S1$  = superelevation of first curve

$S2$  = superelevation of second curve

$m$  = gradient of straight between the two curves

These values are derived from the input data required by minor options 125/135. The input data is:

$V1$  = vertical offset/crossfall to be applied at the start

$V2$  = vertical offset/crossfall to be applied at the end

$L1$  = length of the first circular arc

$L2$  = length of the second circular arc

$L$  = total length of the application

From this data the following values are derived:

**Figure 8 - 18 Circular reverse curve - vertical**



### Biquadratic reverse curve formula

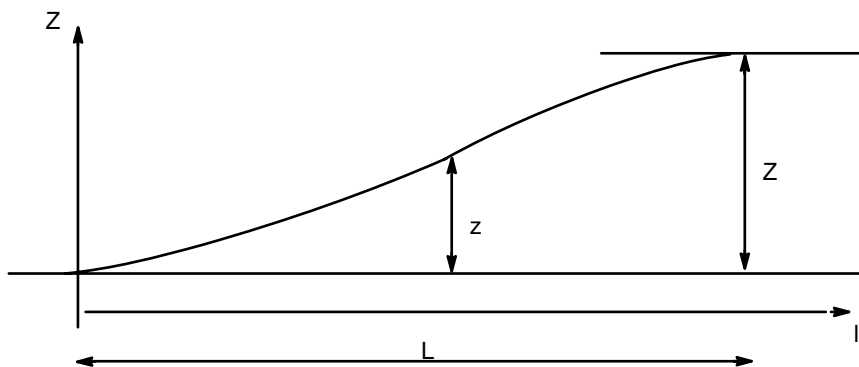
The formula used to apply biquadratic reverse curves in minor options 126 and 136 is of the following form:

$$z = \frac{2l^2 Z}{L^2}$$

For  $l < \frac{L}{2}$

For  $l > \frac{L}{2}$

$$z = Z - \frac{2Z(L-l)^2}{L^2}$$



where:

$L$  = total length of the application

$Z$  = total difference in level

**Figure 8 - 19 Biquadratic reverse curve - vertical**

## Sign Convention and Units

### Units

Any unit of measuring distance may be used within a set of related models.

### Coordinates

Any cartesian coordinate system may be used. The x and y coordinates must never be negative. Levels (z coordinate) may be positive or negative.

### Offset

In all circumstances where an offset is specified the convention for the sign is: Moving in the direction in which the reference string was created, offsets are negative to the left, positive to the right.

### Crossfall

A crossfall is considered to be positive with respect to a reference string if the resultant plane lies above the reference string or negative if it lies below the reference string.

Crossfall is expressed as a decimal fraction - eg 1 in 20 = 0.05.

## French Design Rules

French design rules dictate the formulae to be used for transitions based on the road type and design speed. Within these rules transitions are calculated to ensure sufficient length is available to permit any necessary change in crossfall. The length of transition is also affected by Road Type, Road Speed, Number of lanes and construction.

The crossfalls are not actually applied to any string for the calculation of the transition length. They are used only to assign values to the calculation of the transition length. Once the transition lengths are set the carriageway edge strings may be created with automatic application of superelevation.

Over curves of fixed radius the superelevation is derived from the following table.

<b>DESIGN SPEED = 40</b>	ASPHALT		CONCRETE	
	Inner	Outer	Inner	Outer
Radius > 400	-2.5	-2.5	-2.0	-2.0
400 > R > 250	-2.5	+2.5	-2.0	+2.0
	Linear	Linear	Linear	Linear
250 > R > 40	-2.5 :-7	+2.5 :+7	-2.0 :-7	+2.5 :+7
40 > R	-7	+7	-7	+7

<b>DESIGN SPEED = 60</b>	ASPHALT		CONCRETE	
	Inner	Outer	Inner	Outer
Radius > 600	-2.5	-2.5	-2.0	-2.0
600 > R > 450	-2.5	+2.5	-2.0	+2.0
	Linear	Linear	Linear	Linear
450 > R > 120	-2.5 :-7	+2.5 :+7	-2.0 :-7	+2.5 :+7
120 > R	-7	+7	-7	+7

<b>DESIGN SPEED = 80</b>	ASPHALT		CONCRETE	
	Inner	Outer	Inner	Outer

Radius > 900	-2.5	-2.5	-2.0	-2.0
900 > R > 650	-2.5	+2.5	-2.0	+2.0
	Linear	Linear	Linear	Linear
650 > R > 240	-2.5 :-7	+2.5 :+7	-2.0 :-7	+2.5 :+7
240 > R	-7	+7	-7	+7

DESIGN SPEED = 100	ASPHALT		CONCRETE	
	Inner	Outer	Inner	Outer
Radius > 1300	-2.5	-2.5	-2.0	-2.0
1300 > R > 900	-2.5	+2.5	-2.0	+2.0
	Linear	Linear	Linear	Linear
900 > R > 425	-2.5 :-7	+2.5 :+7	-2.0 :-7	+2.5 :+7
425 > R	-7	+7	-7	+7

DESIGN SPEED = 120	ASPHALT		CONCRETE	
	Inner	Outer	Inner	Outer
Radius > 1800	-2.5	-2.5	-2.0	-2.0
1800 > R > 1500	-2.5	+2.5	-2.0	+2.0
	Linear	Linear	Linear	Linear
500 > R > 665	-2.5 :-7	+2.5 :+7	-2.0 :-7	+2.5 :+7
665 > R	-7	+7	-7	+7

The above rules may be applied to strings which have already been created in the horizontal plane. The rules are applied using the standard DESIGN option 133 by prefacing the option with minor option 017, FDES to invoke the French method.

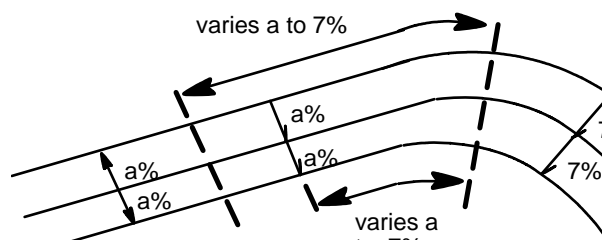
Where transitions occur between elements the rules applied are shown in Figure 8 - 20.

**Inner Channel**

Maintain constant crossfall until outer channel crossfall equals that of the inner channel then linearly vary at the same rate as the outer channel

**Outer Channel**

Apply linear change of crossfall over the length of transition



**Figure 8 - 20 Inter-element transition rules**

# Major option DESIGN

## Access to major option DESIGN

IGENLT.DAT, GEN004

Design options
ALIGNMENT
H & V alignment design
SECTION
Extraction of sections
DESIGN
Feature strings
INTERFACE
Earthworks design
DRAINAGE
Design and analysis
EDIT
Strings and points
COPY
Copy/move model data
REPORT
Models/strings/points

Design options
ALIGNMENT
SECTION
DESIGN
INTERFACE
DRAINAGE
EDIT
COPY
REPORT

## Models for DESIGN

### Input

### Graphics

IGDESIT.DAT, DES001, DES002

DESIGN model requirements	DESIGN options
Ref & sub string model	Add comments to input log
New string model (optional)	Define system parameters
	Define linear units
	Add/amend string
	Add levelsAdd/amend levels
	Add M-string
	Report displacements
	End DESIGN

### Linemode

Major option DESIGN

1st Model 1 Model containing reference and subsidiary strings.

2nd Model 2 Model to contain the new or amending string if different from the first model name, otherwise blank.

◇ *A second model cannot be specified for minor options 104 to 108.*

## Global minor options

The global options 000, 017, 018, 019, 900, and 999 may be used with DESIGN.

## Minor option 017 Define system parameters

This minor option may be used to define any required parameters prior to using the DESIGN options.

### Input

### Graphics

IGDESIT.DAT, DES050

Define system parameters	Define system parameters
Curve fitting status (T)	Angular output units (T)
Input coord notation (T)	Survey station str. label
Angular input units (T)	Secondary inter. tolerance
English/French design (T)	Point search tolerance
Triangle error echo (T)	Left section offset tol.
Triangle FLAT/NOFL (T)	Section baseline bearing
Vertical/Normal offsets (T)	Secondary interp offset
French road type (T)	Right section offset tol.
Output coord notation (T)	
Angular output units (T)	

### Linemode

Vertical or normal offsets may be used with minor options 103, 104 and 105.

#### Minor option 017

Field 1      VOFF - use vertical offsets  
               NOFF - use normal offsets

French superelevation rules may be invoked by coding option 017.

#### Minor option 017

Field 1      Code FDES to use the French method to derive the superelevation to be applied.

Field 2      French Design Route types  
               AR = Autoroute (Motorway)  
               RPN = RNational route principale (major road)  
               UR = Route urbaine (Urban road)

## Minor option 100 Add string: constant H / constant C

This minor option will generate, extend or amend a section of string between normals erected on a reference string offsetting horizontally normal to the reference string according to various mathematical functions and at the same time optionally apply a constant vertical crossfall. The crossfall is calculated along the normal to the reference string.

### Input

### Graphics

IGDESIT.DAT, DES002, DES003, DES004

DESIGN options:	Add/amend string	Constant H / constant C
Add comments to input log	Add comments to input log	New/existing string label
Define system parameter:	Constant H / constant C	Subsidiary string label
Define linear units	Linear H / constant C	Reference string label
Add/amend string	Reverse H / constant C	Crossfall
Add levelsAdd/amend level	Extend/contract crossfall	Start chainage / X coord
Add M-string	Horiz ext of slope/offset	Start point no. / Y coord
Report displacement:	Intersection of 2 slopes	Horizontal offset
End DESIGN	Hard shoulder design	End chainage / X coord
	Subgrade design	End point no. / Y coord
	Constant H / constant V	

### Linemode

#### Constant offset

#### Minor option 100

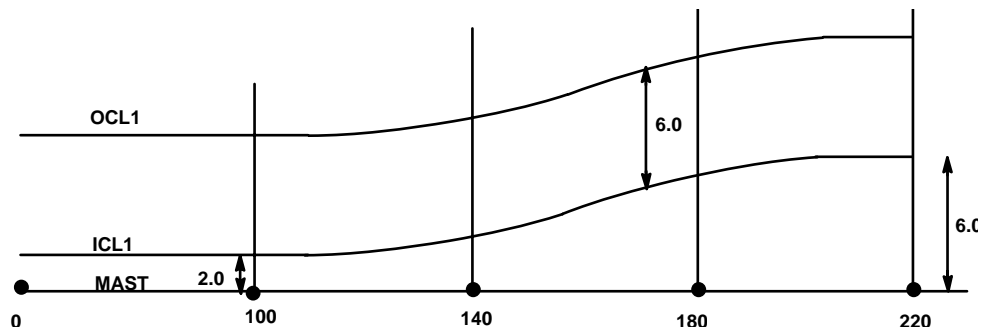
- \* Field 1 Reference string.
- Field 2 Subsidiary string (optional)
- \* Field 3 New, extended or amended string.
- Field 4 Crossfall to be applied with respect to the subsidiary string (reference string by default).  
If zero is coded the resultant level of the new string will be the same as the subsidiary string; if the field is left blank the levels will be set to -999.0
- Field 5 & 6 SPRD start.
- \* Field 7 Constant horizontal offset to be applied.
- Field 8 & 9 SPRD end.

Examples

The examples show typical uses of the option.

```

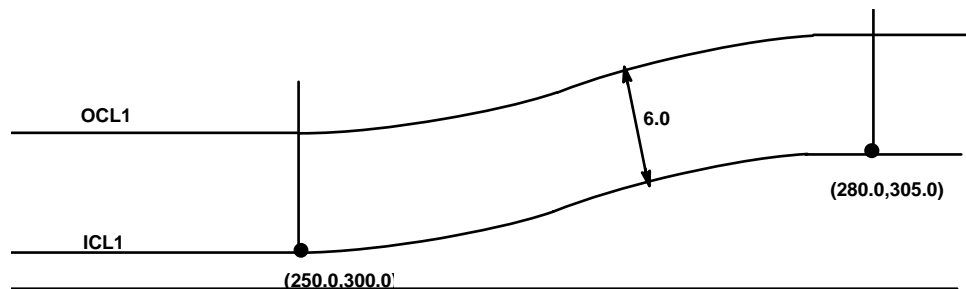
DESIGN, NEW THORNBROUGH
GENERATE INNER AND OUTER CHANNELS FROM MASTER
ALIGNMENT
100,MAST,,ICL1,5=0.0,7=-2,100.0
102,MAST,,ICL1,5=100.0,7=-2,200.0,10=-6.0
100,MAST,ICL1,OCL1,5=0.0,, -6.0,220.0
999
    
```



**Figure 8 - 21** Generate inner and outer channels from master alignment

```

DESIGN, NEW THORNBROUGH
GENERATE OUTER CHANNEL FROM INNER CHANNEL
100,ICL1,,OCL1,5=250.0,300.0,-6.0,280.0,305.0
999
    
```



**Figure 8 - 22** Generate outer channel from inner channel

Note that the strings OCL1 generated in the above example are not the same. In the first case the offset is normal to the master alignment MAST, in the second case the offset is normal to ICL1.

It is possible in the case of linear and reverse curve offsetting for resultant string to cross the reference string. If this occurs the sign of the crossfall is changed once the crossover occurs.



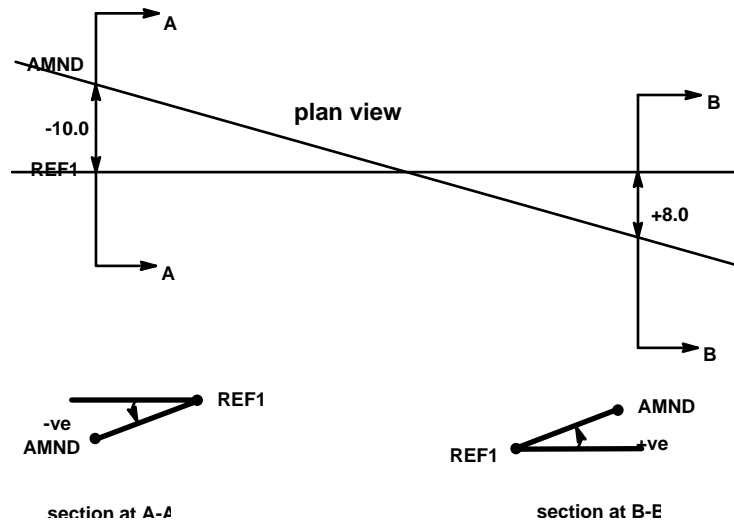


Figure 8 - 23 Resulting string crossing reference string

### Minor option 101 Add string: linear H / constant C

This minor option will generate, extend or amend a section of string between normals erected on a reference string offsetting horizontally normal to the reference string according to various mathematical functions and at the same time optionally apply a constant vertical crossfall. The crossfall is calculated along the normal to the reference string.

#### Input

#### Graphics

IGDESIT.DAT, DES002, DES003, DES005

DESIGN options	Add/amend string	Linear H / constant C
Add comments to input log	Add comments to input log	New/existing string label
Define system parameter:	Constant H / constant C	Subsidiary string label
Define linear units:	Linear H / constant C	Reference string label
Add/amend string	Reverse H / constant C	Crossfall
Add levelsAdd/amend level	Extend/contract crossfall	Start chainage / X coord
Add M-string	Horiz ext of slope/offset	Start point no. / Y coord
Report displacement:	Intersection of 2 slopes	Horizontal offset at start
End DESIGN	Hard shoulder design	End chainage / X coord
	Subgrade design	End point no. / Y coord
	Constant H / constant V	Horizontal offset at end

Linemode

**Linear increasing/decreasing horizontal offset**

Minor option 101

- \* Field 1      Reference string.
- Field 2      Subsidiary string (optional)
- \* Field 3      New, extended or amended string.
- Field 4      Crossfall to be applied with respect to the subsidiary string (reference string by default).  
If zero is coded the resultant level of the new string will be the same as the subsidiary string; if the field is left blank the levels will be set to -999.0
- Field 5 & 6   SPRD start.
- \* Field 7      Horizontal offset required at start point.
- Field 8 & 9   SPRD end.
- \* Field 10     Horizontal offset required at end point.

**Minor option 102    Add string: reverse H / constant C**

This minor option will generate, extend or amend a section of string between normals erected on a reference string offsetting horizontally normal to the reference string according to various mathematical functions and at the same time optionally apply a constant vertical crossfall. The crossfall is calculated along the normal to the reference string.

**Input**

Graphics

IGDESIT.DAT, DES002, DES003, DES006

DESIGN options	Add/amend string	Reverse H / constant C
Add comments to input log	Add comments to input log	New/existing string label
Define system parameters	Constant H / constant C	Subsidiary string label
Define linear units	Linear H / constant C	Reference string label
Add/amend string	Reverse H / constant C	Crossfall
Add levelsAdd/amend levels	Extend/contract crossfall	Start chainage / X coord
Add M-string	Horizext of slope/offset	Start point no. / Y coord
Report displacements	Intersection of 2 slopes	Horizontal offset at start
End DESIGN	Hard shoulder design	End chainage / X coord
	Subgrade design	End point no. / Y coord
	Constant H / constant V	Horizontal offset at end

**Linemode****Horizontal offset varying according to a reverse symmetrical curve****Minor option 102**

- \* Field 1      Reference string.
- Field 2      Subsidiary string (optional)
- \* Field 3      New, extended or amended string.
- Field 4      Crossfall to be applied with respect to the subsidiary string (reference string by default).  
If zero is coded the resultant level of the new string will be the same as the subsidiary string; if the field is left blank the levels will be set to -999.0
- Field 5 & 6    SPRD start.
- \* Field 7      Horizontal offset required at start point.
- Field 8 & 9    SPRD end.
- \* Field 10     Horizontal offset required at end point.

**Minor option 103    Add string: extend/contract crossfall**

This minor option will generate, extend or amend a section of string between normals erected on a reference string. Points on the string are defined by offsetting horizontally from the subsidiary string and normal to the reference string. The levels are determined by extending the crossfall between the reference and subsidiary string in the direction of the normal and applying a constant vertical offset.

Input

Graphics

IGDESIT.DAT, DES002, DES003, DES007

DESIGN options	Add/amend string	Extend/contract crossfall
Add comments to input log	Add comments to input log	New/existing string label
Define system parameters	Constant H / constant C	Subsidiary string label
Define linear units	Linear H / constant C	Reference string label
Add/amend string	Reverse H / constant C	Vertical offset
Add levelsAdd/amend levels	Extend/contract crossfall	Start chainage / X coord
Add M-string	Horiz ext of slope/offset	Start point no. / Y coord
Report displacements	Intersection of 2 slopes	Horizontal offset
End DESIGN	Hard shoulder design	End chainage / X coord
	Subgrade design	End point no. / Y coord
	Constant H / constant V	

Linemode

Minor option 103

- \* Field 1 Reference string.
- Field 2 Subsidiary string (optional)
- \* Field 3 New, extended or amended string.
- Field 4 Vertical offset.

If zero is coded the resultant level of the new string will lie on the plane formed by the reference and be the same as the subsidiary strings, if the field is blank the levels will be set to -999.0.

- Field 5 & 6 SPRD start.
- \* Field 7 Horizontal offset to be applied.
- Field 8 & 9 SPRD end.

Example

This example illustrates the use of the option to create highway sub-reference strings.

```

DESIGN,NEW THORNBOROUGH,NEW THORNBOROUGH SUBGRADE
  GENERATE SUBGRADE STRINGS SUB1 AND SUB2 WITH
  REFERENCE TO STRINGS ICO3 AND OCO3 BETWEEN
  POINTS 1 AND 65
103,OCO3,ICO3,SUB1,-0.70,6=1.0,-0.5,9=65.0
103,ICO3,OCO3,SUB2,-0.70,6=1.0,1.0,9=65.0
999
  
```

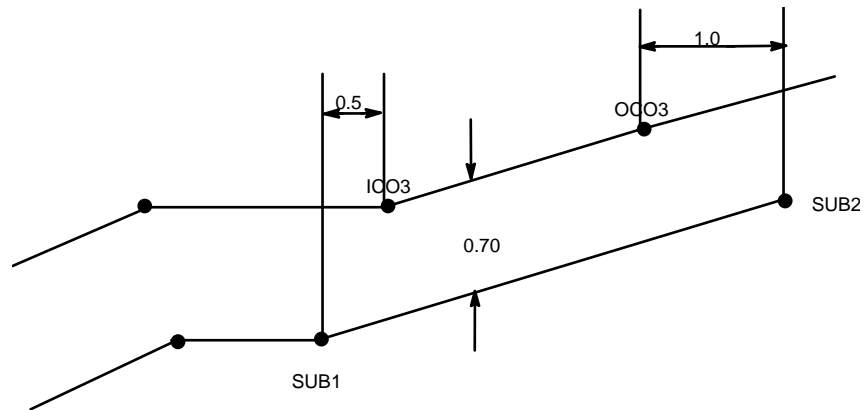


Figure 8 - 24 Creation of highway sub-reference strings

The technique can be used to locate setting out profiles. The strings LCRS and RCRS are theoretical strings defining a sight line parallel to the carriageway surface.

```

DESIGN, NEW THORNBOROUGH
  GENERATED STRINGS LCRS AND RCRS FOR SETTING OUT
  PROFILES BETWEEN CHAINAGES 60.0 AND 520.0
103,M009,RC09,RCRS,1.0,60.0,,2.0,520.0
103,M009,LC09,LCRS,1.0,60.0,, -2.0,520.0
999
  
```

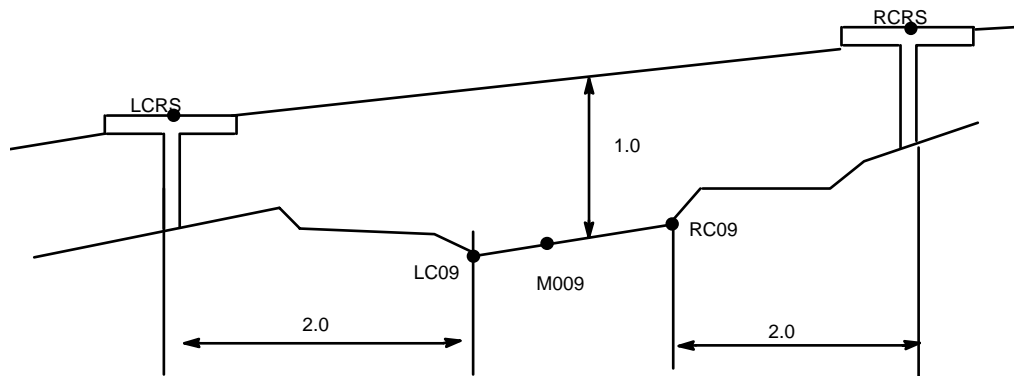


Figure 8 - 25 Setting out profiles

## Minor option 104 Horizontal extension of slope/offset

### Input

### Graphics

IGDESIT.DAT, DES002, DES003, DES008

DESIGN options	Add/amend string	Horiz ext of slope/offset
Add comments to input log	Add comments to input log	New/existing string label
Define system parameters	Constant H / constant C	Reference string label
Define linear units	Linear H / constant C	Start chainage / X coord
Add/amend string	Reverse H / constant C	Start point no. / Y coord
Add levelsAdd/amend levels	Extend/contract crossfall	End chainage / X coord
Add M-string	Horiz ext of slope/offset	End point no. / Y coord
Report displacements	Intersection of 2 slopes	String 1 defining slope
End DESIGN	Hard shoulder design	String 2 defining slope
	Subgrade design	Vertical/normal offset
	Constant H / constant V	Horizontal offset

### Linemode

An initial minor option 103 defines the reference strings and the new string label and the extents of the application. This is followed by a 104 option to define the slope and the horizontal offset and vertical offsets.

#### Minor option 103

- \* Field 1 Reference string.
- \* Field 3 New string.

Field 5 & 6 SPRD start.

Field 8 & 9 SPRD end.

Minor option 104

- \* Field 2 First string defining slope definition (S1.)
  - \* Field 3 Second string defining slope definition (S2).
  - \* Field 4 Vertical or normal offset to be applied (V).  
The offset is considered to be vertical or normal depending upon the setting specified by minor option 017, 'Define system parameters'.
  - \* Field 7 Horizontal offset to be applied (H) from S2.
- ◇ *Slope is positive if it rises to the right (looking in direction of the string) and negative if it falls to the right.*

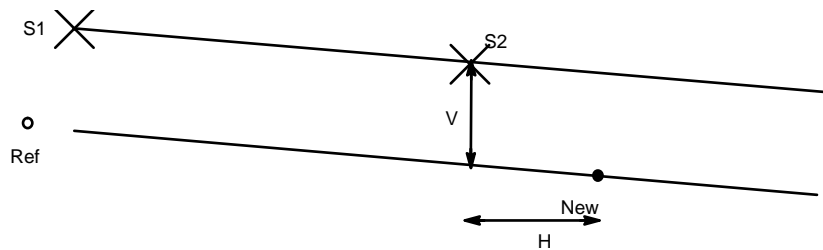


Figure 8 - 26 Example - option 104

Example

```
103 , M003 , , CR01 , 5=3900 , 9=5700
104 , 2=SUB1 , SUB2 , 4=0.05 , 7=12.75
```

Minor option 105 Intersection of 2 slopes

This option creates a string by calculating the intersection of two planes. Each plane can be defined by:

- Two strings
- One string and an angle of slope passing through it.

Once the plane has been defined, an offset can be applied to it before the position of the new string is calculated. The offset can be defined as a difference in height (a vertical offset) or a difference in thickness (a normal offset).

Input

Graphics

IGDESIT.DAT, DES003, DES009, DES010

Add/amend string	Intersection of 2 slopes	Intersection of 2 slopes
Add comments to input log	New/existing string label	First slope start string
Constant H / constant C	Reference string label	First slope end string
Linear H / constant C	Start chainage / X coord	Vertical/normal offset
Reverse H / constant C	Start point no. / Y coord	Slope at start
Extend/contract crossfall	End chainage / X coord	Slope at end
Horiz ext of slope/offset	End point no. / Y coord	Second slope start string
Intersection of 2 slopes		Second slope end string
Hard shoulder design		Vertical/normal offset
Subgrade design		Slope at start
Constant H / constant V		Slope at end

Two minor option 105 records must follow an initial option 103.

Minor option 103

- \* Field 1 Reference string.
- \* Field 3 New string.
- Field 5 & 6 SPRD start.
- Field 8 & 9 SPRD end.

Definition of slope extension between two existing strings

Minor option 105

- \* Field 2 First string defining slope definition.
- \* Field 3 Second string defining slope definition.
- Field 4 Vertical or normal offset to be applied.

The offset is measured from the second string defining the slope definition.

The offset is considered to be vertical or normal depending upon the setting specified by minor option 017, 'Define system parameters'.

The sign of the offset is positive if the offset is above the plane being considered and negative if it is below.



**Definition of slope by explicit definition**

**Minor option 105**

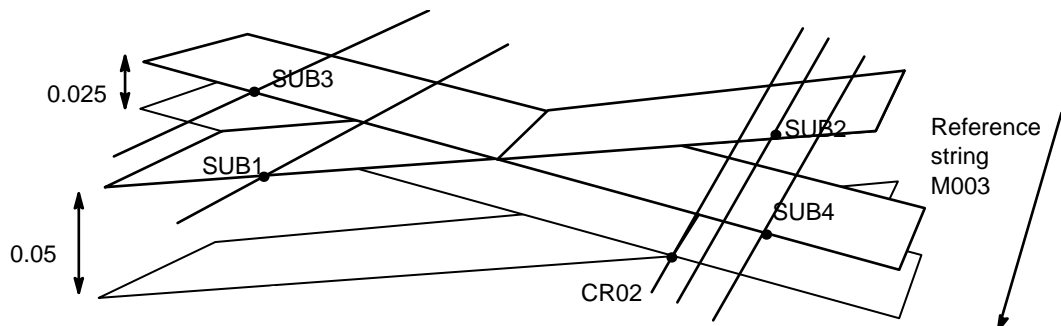
- \* Field 2      String to which slope is related.
  - Field 4      Vertical or normal offset to be applied.  
The offset is measured from the second string defining the slope definition.  
The offset is considered to be vertical or normal depending upon the setting specified by minor option 017, 'Define system parameters'.  
The sign of the offset is positive if the offset is above the plane being considered and negative if it is below.
  - \* Field 7      Slope to be applied at start of application.
  - Field 10     Slope to be applied at end of application. If left blank a constant slope as defined in field 7 is applied.
- ◇ *Slope is positive if it rises to the right (looking in direction of the reference string) and negative if it falls to the right.*

**Example 1**

This example creates the string CR02 using three different methods. In all cases, the offsets specified are vertical offsets, ie, differences in height.

```

DEFINE BOTH SLOPES AS EXTENSIONS OF SLOPE
017,VOFF
103,M003,,CR02,5=3900,8=5700
105,2=SUB1,SUB2,4=-0.05
105,2=SUB3,SUB4,4=-0.025
DEFINE SLOPES AS ONE OF EACH
103,M003,,CR02,5=3900,8=5700
105,2=SUB1,SUB2,4=-0.05
105,2=SUB3,4=-0.025,7=0.10
DEFINE BOTH SLOPES EXPLICITLY
103,M003,,CRO2,5=3900,8=5700
105,2=SUB1,4=0.05,7=-0.20
105,2=SUB3,4=0.025,7=0.10
    
```



**Figure 8 - 27 Example - slope by explicit definition**

### Example 2

This example shows the possible subgrade strings which may be generated using a combination of minor options 103, 104 and 105. The subgrade strings are specified using normal offsets.

String SUB1 is an intersection of the profiles defined by:

- a normal offset from STR1 and STR2
- STR2 and STR3

String SUB2 is an intersection of the profiles defined by:

- a normal offset from STR1 and STR2
- a horizontal plane through STR2 at a zero vertical offset

String SUB3 is an intersection of the profiles defined by:

- a normal offset from STR1 and STR2
- a normal offset from STR2 and STR3

String SUB4 is an intersection of the profiles defined by:

- extension of the normal offset from STR2 and STR3
- a vertical plane through STR2

String SUB5 is an intersection of the profiles defined by:

- a normal offset from STR2 and STR3
- STR1 and STR2

```
DESIGN,NEW THORNBOROUGH,EXAMPLE SUBGRADE STRINGS
GENERATE EXAMPLE SUBGRADE STRINGS USING NORMAL
OFFSETS
017,NOFF
```

```
GENERATE SUB1
103,M001,,SUB1
105,,STR1,STR2,-0.1
105,,STR2,STR3,0.0
```

```
GENERATE SUB2
103,M001,,SUB2
105,,STR1,STR2,-0.1
105,,STR2,4=0.0,7=0.0
```

```
GENERATE SUB3
103,M001,,SUB3
105,,STR1,STR2,-0.1
105,,STR2,STR3,-0.1
```

```
GENERATE SUB4
103,M001,,SUB4
104,,STR3,STR2,-0.1,7=0
```

```
GENERATE SUB5
103,M001,,SUB5
105,,STR1,STR2,0.0
105,,STR2,STR3,-0.1
```

```
999
```

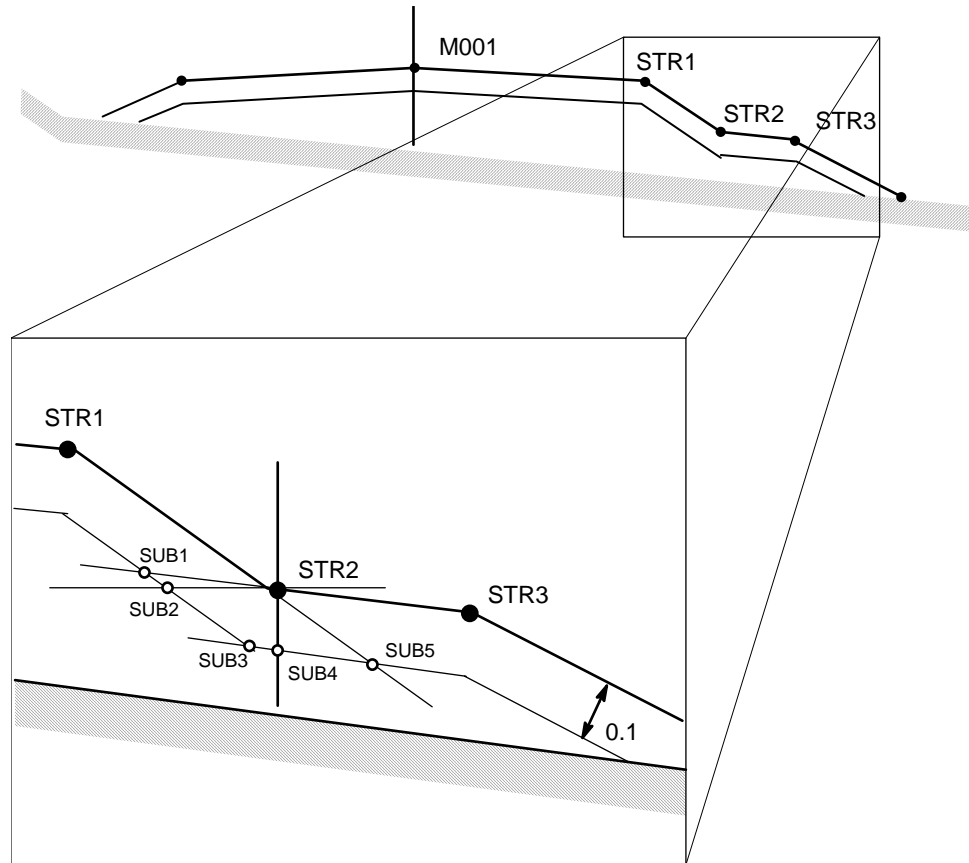


Figure 8 - 28 Intersection of profiles using normal offsets

## Minor option 106 Hard shoulder design

Generates hard shoulder strings according to specific design criteria. Both the plan position and the level may be derived automatically. This option also defines:

- The hard shoulder crossfall.
- The length of the changeover between two hard shoulder crossfalls.
- The width of the hard shoulder.

To satisfy specific design criteria such as French, it is recommended that any change in crossfall occurs within the length of the horizontal transition.

### Hard shoulder crossfall

The crossfall applied to the hard shoulder strings is dependent upon the value of the carriageway crossfall,  $C_f$ , which is categorised in three bands as follows:

$$-4.0\% \leq C_f \leq +4.0\%$$

Both the inner and outer hard shoulder strings are generated with a -4.0% crossfall by default.

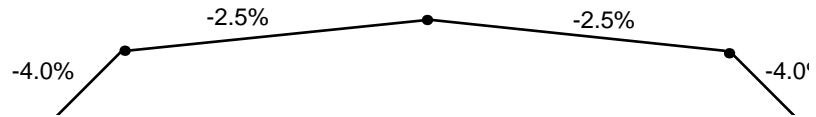


Figure 8 - 29 Hard shoulder crossfall -4.0% (standard case)

**$C_f > +4.0\%$**

The outer hard shoulder strings are generated with a -1.5% crossfall by default.



Figure 8 - 30 Outer hard shoulder crossfall -1.5%

**$C_f < -4.0\%$**

The inner hard shoulder strings are generated with the same crossfall as the carriageway.

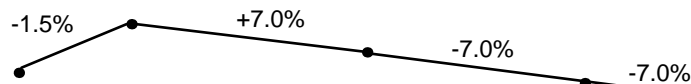
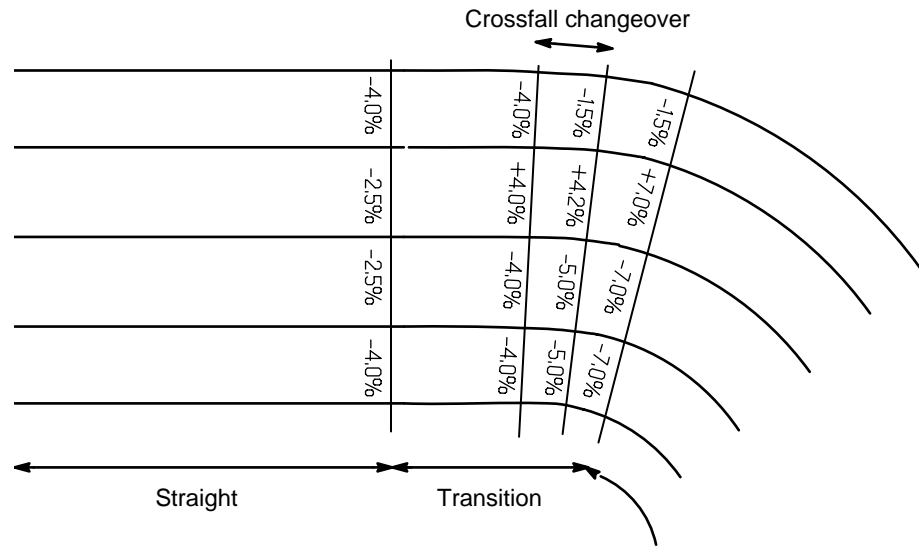


Figure 8 - 31 Inner hard shoulder crossfall -7.0%

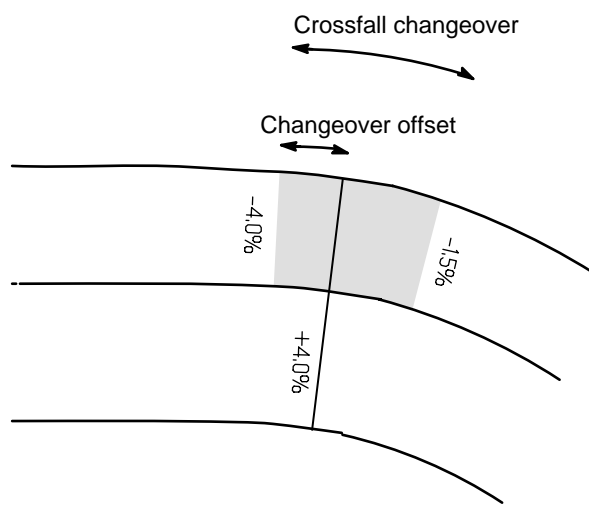
**Crossfall changeover**

If the carriageway crossfall changes from +4.0% to just over +4.0%, the hard shoulder crossfall changes from -4.0% to -1.5%. This changeover can be varied over a user defined length to make the changeover less abrupt.



**Figure 8 - 32 Crossfall changes in the hard shoulder**

Additionally, the changeover offset may be specified, which determines the distance between the start of the crossfall changeover and the point where the carriageway crossfall moves above +4.0%.



Shaded area can be positioned anywhere on a transition

**Figure 8 - 33 Changeover offset**

The changeover offset is the same across a pair of transitions, so that symmetry is maintained (see Figure 8 - 34 ).

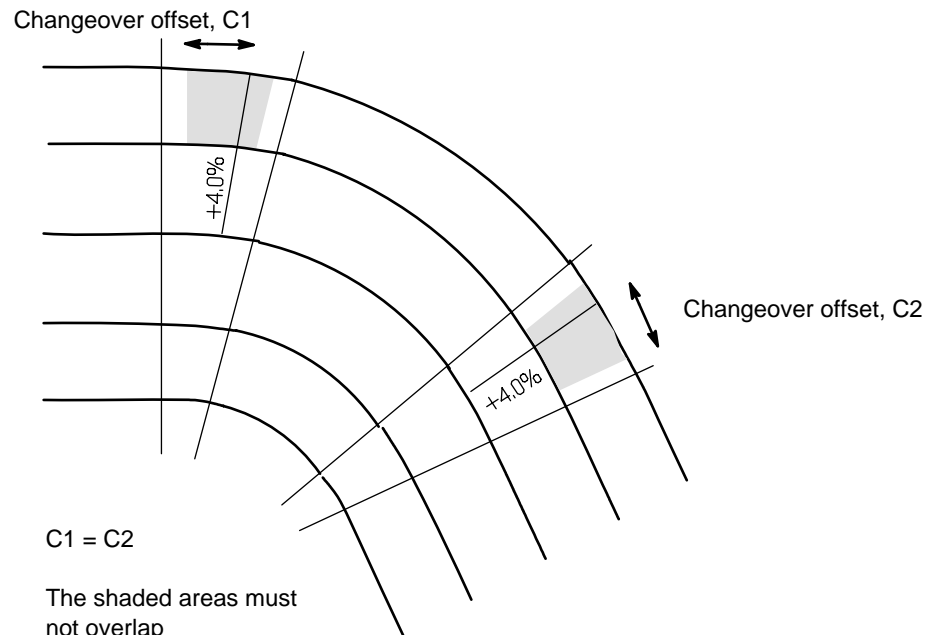


Figure 8 - 34 Changeover offset symmetry

### Hard shoulder width

The width of the hard shoulder can be made to vary linearly by specifying offsets from the edge of the carriageway at start and end points.

### Input

### Graphics

IGDESIT.DAT, DES003, DES011, DES059

Add/amend string	Hard shoulder design	Hard shoulder design
Add comments to input log	Reference string label	1st string defining plane
Constant H / constant C	New/existing string label	2nd string defining plane
Linear H / constant C	Start chainage / X coord	Standard crossfall
Reverse H / constant C	Start point no. / Y coord	Min external curve X-fall
Extend/contract crossfall	End chainage / X coord	Start hard shoulder offset
Horiz ext of slope/offset	End point no. / Y coord	Changeover length
Intersection of 2 slopes		Changeover offset
Hard shoulder design		End hard shoulder offset
Subgrade design		
Constant H / constant V		

Linemode

Minor option 106 must follow an initial option 103.

Minor option 103

- \* Field 1 Reference string.
- \* Field 3 Hard shoulder string.
- Field 5 & 6 SPRD start.
- Field 8 & 9 SPRD end.

Minor option 106

- \* Field 2 First string defining carriageway slope.
- \* Field 3 Second string defining carriageway slope.  
Hard shoulder offsets are measured from this string.
- Field 4 Outer curve hard shoulder crossfall (default value -0.015).  
This crossfall is applied when the carriageway crossfall  $C_f > 4.0\%$ .
- Field 5 Standard hard shoulder crossfall (default value -0.040).  
This crossfall is applied when the carriageway crossfall,  $C_f$ , is within the range  $-4.0\% \leq C_f \leq +4.0\%$ .
- Field 7 Horizontal offset at start point (default value 0).
- Field 8 Crossfall changeover length (default value 0).  
If a changeover length is specified, additional points are inserted into the hard shoulder string at the start and end of the changeover.
- Field 9 Changeover offset (default value 0).  
This is the distance between the start of the crossfall changeover and the point where the carriageway crossfall moves above +4.0%.
- Field10 Horizontal offset at end point (default value = Field 7).

Example 1

This example uses the default hard shoulder crossfalls of -1.5% and -4.0% and varies the width of the left hand hard shoulder from 3.5m to 3.0m between chainages 250 and 280m. The changeover length is 20m.

```
103,MAST,,HLEF,8=250
106,,CILF,COLF,7=-3.5,20
103,MAST,HLEF,5=250,8=280
106,,CILF,COLF,7=-3.5,10=-3.0
103,MAST,,HLEF,5=280
106,,CILF,COLF,7=-3.0
```

Example 2

This example applies a hard shoulder crossfall of -3.0% when the carriageway crossfall is less than 4.0% (ie, on a straight), and -1.0% when



the carriageway crossfall is greater than 4.0% (ie, on a bend). The changeover between the two will take 30m, and will be offset by 20m.

103 , MAST , , HLEF

106 , , CILF, COLF, -0.01, -0.03, 7=-3.5, 30, 20

## Minor options 107/108 Automatic subgrade design

Having already created surface strings by applying design rules to alignment transitions and superelevation, the subgrade surface feature may be similarly automatically created. The subsurface may be designed at a user defined vertical offset and at a gradient dependent on the carriageway crossfall.

Two situations exist:

- i) Single carriageways and dual carriageways without central reservation.
- ii) Dual carriageways with central reservation.

In the first case, the position at which the critical point is measured can be at the centre line or either channel depending upon the carriageway crossfall and horizontal radius (see Figure 8 - 35 ).

In the second case the critical point is only measured from one or other of the channels, for each carriageway (see Figure 8 - 36 ).

The rules for application of crossfall are:

- i) Single carriageway or dual carriageway without central reservation.

Carriageway crossfall	Critical point position	Subgrade crossfall
≤0%	Centre line	-4%
0% to 4%	Outer Channel	Same as carriageway crossfall
>4%	Centre line	+4%

- ii) Dual carriageway with central reservation.

Carriageway crossfall	Critical point		Subgrade crossfall
	Left	Right	
≤0%	Inner ch	Inner ch	-4%
0% to 4%	Outer ch	Inner ch	+4%
>4%	Inner ch	Inner ch	Same as carriageway crossfall

For the purpose of this option, a carriageway can be assumed to be defined by 3 strings.

## Minor option 107/108 Subgrade design

### Input

### Graphics

IGDESIT.DAT, DES003, DES051, DES052

Add/amend string	Subgrade design	Subgrade design
Add comments to input log	Upper surface C/L string	Lower surface C/L string
Constant H / constant C	Upper surface L/C string	Lower surface L/C string
Linear H / constant C	Upper surface R/C string	Lower surface R/C string
Reverse H / constant C	Subgrade crossfall	Vertical offset
Extend/contract crossfall	Start chainage / X coord	Horizontal offset to left
Horiz ext of slope/offset	Start point no. / Y coord	Horizontal offset to right
Intersection of 2 slopes	End chainage / X coord	
Hard shoulder design	End point no. / Y coord	
Subgrade design	Road type indicator (T)	
Constant H / constant V		

### Linemode

Two options are used, one to analyse the carriageway surface crossfalls and another to design the subgrade.

Because the critical depth position changes throughout the analysis, 3 strings (ie 2 planes) must be considered to enable 3 subgrade strings to be created at one time.

#### Minor option 107

- \* Field 1 Upper surface centre line string
- \* Field 2 Upper surface left channel string
- \* Field 3 Upper surface right channel string
- Field 4 % gradient at which subgrade crossfall will change
- Field 5 & 6 SPRD start
- Field 8 & 9 SPRD end
- \* Field 10 Road type indicator
  - 1 Single c/way and dual c/way with no central reservation
  - 2 Dual c/way with central reservation

#### Minor option 108

- \* Field 1 Lower surface centre line string
- \* Field 2 Lower surface left channel string

- \* Field 3 Lower surface right channel string
- \* Field 4 Vertical offset between upper and lower surfaces
- \* Field 7 Horizontal offset of string in field 2
- \* Field 10 Horizontal offset of string in field 3
- ◇ Centre lines are always coded in field 1
- ◇ Left channel strings are always coded in field 2
- ◇ Right channel strings are always coded in field 3

Example 1

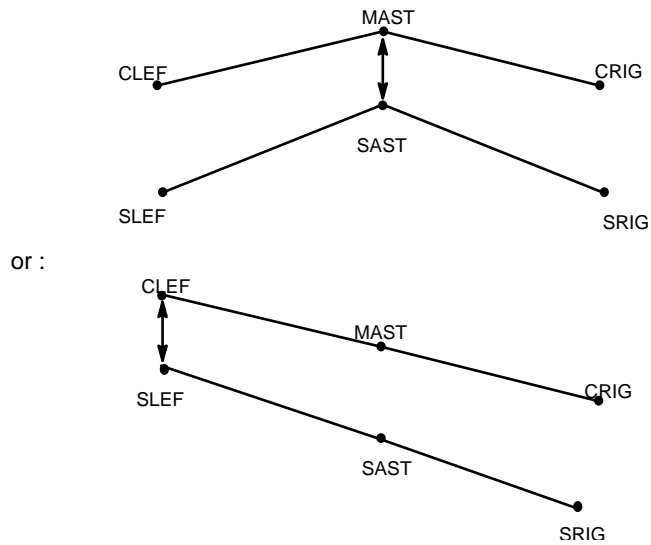


Figure 8 - 35 Example - Left and right channel strings

107,MAST,CLEF,CRIG,0.04,10=1  
 108,SAST,SLEF,SRIG,-1.5

In a central reservation case, the reference string can be the middle of the central reservation, in which case the following coding applies.

Example 2

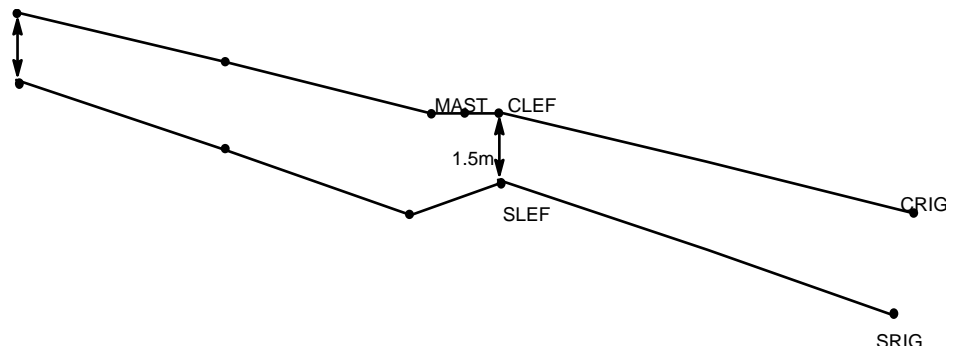


Figure 8 - 36 Example - central reservation

107, MAST, CLEF, CRIG, 4=0.04

108, , SELF, SRIG, -1.5

- SAST is not coded, so is not created.
- The option analyses the slope between CLEF & CRIG and creates SLEF & SRIG.

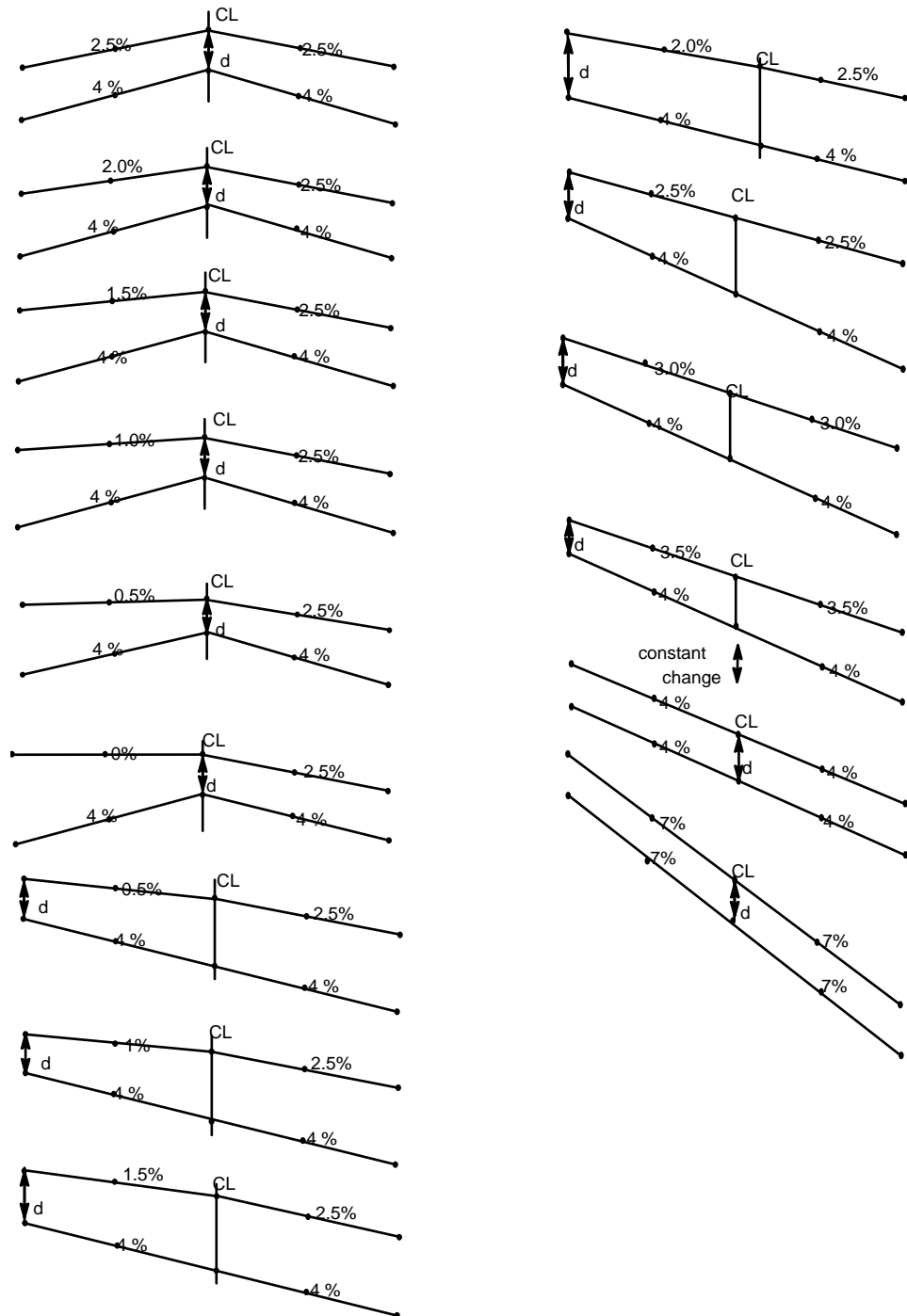
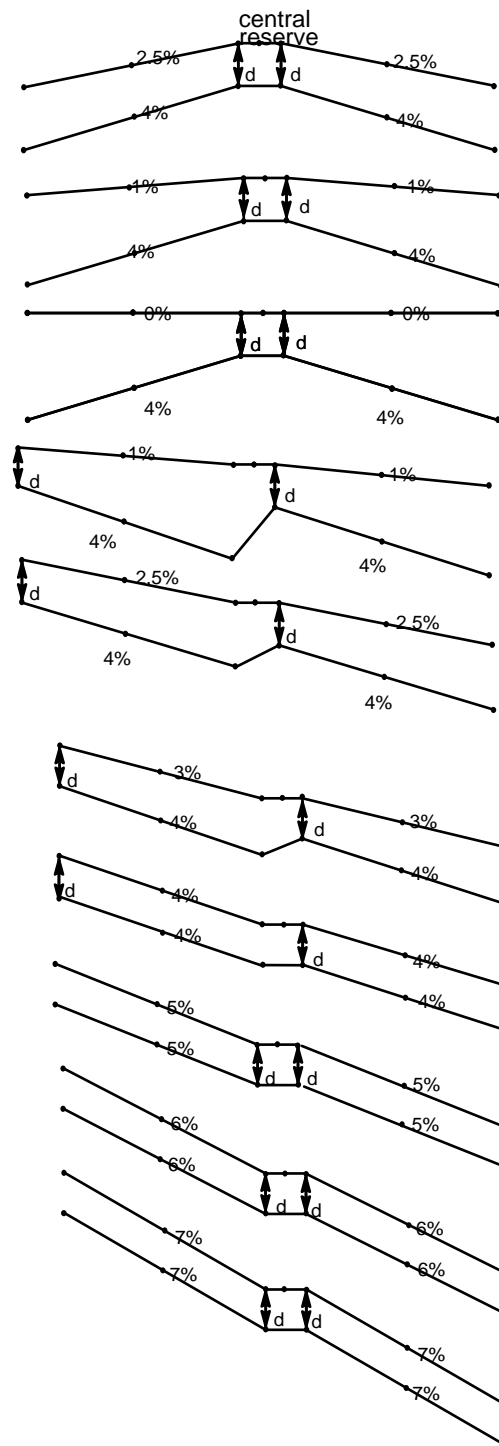


Figure 8 - 37 Auto generation of subgrade strings for string for single carriageway and dual carriageway without central reservation



**Figure 8 - 38 Auto generation of subgrade string for dual carriageway with central reservation**

### Minor option 110 Add string: constant H / constant V

This minor option will generate, extend or amend a section of string between normals erected on a reference string offsetting horizontally,

normal to the reference string according to various mathematical functions and at the same time optionally apply a constant vertical offset.

**Input**

**Graphics**

IGDESIT.DAT, DES002, DES003, DES012

DESIGN options	Add/amend string	Constant H / constant V
Add comments to input log	Add comments to input log	New/existing string label
Define system parameters	Constant H / constant C	Subsidiary string label
Define linear units	Linear H / constant C	Reference string label
Add/amend string	Reverse H / constant C	Vertical offset
Add levelsAdd/amend levels	Extend/contract crossfall	Start chainage / X coord
Add M-string	Horiz ext of slope/offset	Start point no. / Y coord
Report displacements	Intersection of 2 slopes	Horizontal offset
End DESIGN	Hard shoulder design	End chainage / X coord
	Subgrade design	End point no. / Y coord
	Constant H / constant V	

**Linemode**

**Constant offset**

**Minor option 110**

- \* Field 1 Reference string.
- Field 2 Subsidiary string (optional)
- \* Field 3 New, extended or amended string.
- Field 4 Vertical offset to be applied with respect to the subsidiary string (reference string by default).  
If zero is coded the resultant level of the new string will be the same as the subsidiary string, if the field is blank the levels will be set to -999.0.
- Field 5 & 6 SPRD start.
- \* Field 7 Constant horizontal offset to be applied.
- Field 8 & 9 SPRD end.

The use of this option is almost identical to option 100, the only difference being that a constant vertical offset is applied rather than a constant vertical crossfall.

## Minor option 111 Add string: linear H/constant V

This minor option will generate, extend or amend a section of string between normals erected on a reference string offsetting horizontally, normal to the reference string according to various mathematical functions and at the same time optionally apply a constant vertical offset.

### Input

### Graphics

IGDESIT.DAT, DES002, DES003, DES013

DESIGN options	Add/amend string	Linear H / constant V
Add comments to input log	Linear H / constant V	New/existing string label
Define system parameters	Reverse H / constant V	Subsidiary string label
Define linear units	End DESIGN	Reference string label
Add/amend string		Vertical offset
Add levelsAdd/amend levels		Start chainage / X coord
Add M-string		Start point no. / Y coord
Report displacements		Horizontal offset at start
End DESIGN		End chainage / X coord
		End point no. / Y coord
		Horizontal offset at end

### Linemode

#### Linearly increasing/decreasing horizontal offset

##### Minor option 111

- \* Field 1 Reference string.
- Field 2 Subsidiary string (optional)
- \* Field 3 New, extended or amended string.
- Field 4 Vertical offset to be applied with respect to the subsidiary string (reference string by default).  
If zero is coded the resultant level of the new string will be the same as the subsidiary string, if the field is left blank the levels will be set to -999.0.
- Field 5 & 6 SPRD start.
- \* Field 7 Horizontal offset required at start point.
- Field 8 & 9 SPRD end.
- Field 10 Horizontal offset required at end point.

The use of this option is almost identical to option 101, the only difference being that a constant vertical offset is applied rather than a constant vertical crossfall.

## Minor option 112 Add string: reverse H/constant V

This minor option will generate, extend or amend a section of string between normals erected on a reference string offsetting horizontally, normal to the reference string according to various mathematical functions and at the same time optionally apply a constant vertical offset.

### Input

#### Graphics

IGDESIT.DAT, DES002, DES003, DES014

DESIGN options	Add/amend string	Reverse H / constant V
Add comments to input log	Linear H / constant V	New/existing string label
Define system parameters	Reverse H / constant V	Subsidiary string label
Define linear units	End DESIGN	Reference string label
Add/amend string		Vertical offset
Add levelsAdd/amend levels		Start chainage / X coord
Add M-string		Start point no. / Y coord
Report displacements		Horizontal offset at start
End DESIGN		End chainage / X coord
		End point no. / Y coord
		Horizontal offset at end

### Linemode

#### Horizontal offset varying according to a reverse symmetrical curve

##### Minor option 112

- \* Field 1 Reference string.
- Field 2 Subsidiary string (optional)
- \* Field 3 New, extended or amended string.
- Field 4 Vertical offset to be applied with respect to the subsidiary string (reference string by default).  
If zero is coded the resultant level of the new string will be the same as the subsidiary string, if the field is left blank the levels will be set to -999.0.
- Field 5 & 6 SPRD start.



- \* Field 7      Horizontal offset required at start point.  
Field 8 & 9   SPRD end.
- \* Field 10     Horizontal offset required at end point.  
The use of this option is almost identical to option 110, the only difference being that a constant vertical offset is applied rather than a constant vertical crossfall.

## Minor option 120    Amend levels: constant vertical offset

Amend the levels of a section of string by vertical offsetting from an existing string or from a defined level datum.

This minor option will amend the levels in a section of an existing string between normals erected on a reference string. The levels are derived by offsetting a constant distance vertically from a subsidiary string (reference string by default).

Alternatively a datum level may be used instead of the subsidiary string and the vertical offsets applied to this level.

### Input

IGDESIT.DAT, DES002, DES015, DES016

DESIGN options	Add levelsAdd/amend levels	Constant vertical offset
Add comments to input log	Add comments to input log	Existing string label
Define system parameters	Constant vertical offset	Subsidiary string label
Define linear units	Linear vertical offset	Reference string label
Add/amend string	Curved vertical offset	Datum level
Add levelsAdd/amend levels	Spline vertical offset	Start chainage / X coord
Add M-string	Constant crossfall	Start point no. / Y coord
Report displacements	Linear crossfall	Vertical offset
End DESIGN	Curved crossfall	End chainage / X coord
	Superelevation	End point no. / Y coord
	Ext crossfall (2 strings)	

### Linemode

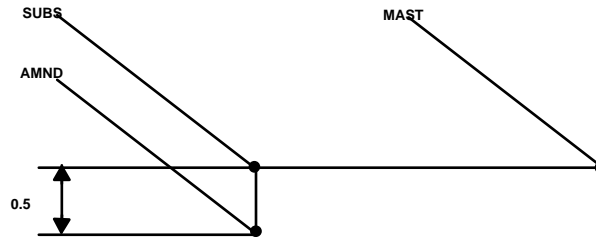
#### Minor option 120

- \* Field 1      Reference string.  
Field 2      Subsidiary string (optional)
- \* Field 3      String to be amended.  
Field 4      Datum level (optional).  
Field 5 & 6   SPRD start.

- \* Field 7      Constant vertical offset to be applied.  
Field 8 & 9    SPRD end.

The examples show typical uses of the option.

```
DESIGN, SIMPLE DESIGN ROAD
  CREATE LEVELS ON A STRING BY VERTICAL OFFSET
120,MAST,SUBS,AMND,,10.0,, -0.5,100.0
999
```



**Figure 8 - 39 Example – Constant vertical offset**

Note that these options may be used for the application of superelevation. It is necessary to be aware of the problem that may arise if the subsidiary (reference) and amended strings are not parallel, in these situations it is better to use the options where the vertical alteration is specified in terms of a crossfall (130 Onwards).

If these options are used to apply superelevation on or about the same string as the reference string (ie about itself) then if the same point is used as the end of one option and the start of another option, the level difference will be applied twice to the same point. This problem is avoided if adjacent points are used in this instance.

## Minor option 121 Amend levels: linear vertical offset

Amend the levels of a section of string by vertical offsetting from an existing string or from a defined level datum.

This minor option will amend the levels in a section of an existing string between normals erected on a reference string. The levels are derived by offsetting vertically from a subsidiary string (reference string by default) according to a linear mathematical function.

Alternatively a datum level may be used instead of the subsidiary string and the vertical offsets applied to this level.

Input

IGDESIT.DAT, DES002, DES015, DES017

DESIGN options	Add levelsAdd/amend levels	Linear vertical offset
Add comments to input log	Add comments to input log	Existing string label
Define system parameters	Constant vertical offset	Subsidiary string label
Define linear units	Linear vertical offset	Reference string label
Add/amend string	Curved vertical offset	Datum level
Add levelsAdd/amend levels	Spline vertical offset	Start chainage / X coord
Add M-string	Constant crossfall	Start point no. / Y coord
Report displacements	Linear crossfall	Vertical offset at start
End DESIGN	Curved crossfall	End chainage / X coord
	Superelevation	End point no. / Y coord
	Ext crossfall (2 strings)	Vertical offset at end

Linemode

Minor option 121

- \* Field 1 Reference string.
- Field 2 Subsidiary string (optional)
- \* Field 3 String to be amended.
- Field 4 Datum level (optional).
- Field 5 & 6 SPRD start.
- \* Field 7 Vertical offset required at start point.
- Field 8 & 9 SPRD end.
- Field 10 Vertical offset required at end point.

**Minor option 122 Amend levels: symmetrical reverse curve offset**

Amend the levels of a section of string by vertical offsetting from an existing string or from a defined level datum.

This minor option will amend the levels in a section of an existing string between normals erected on a reference string. The levels are derived by offsetting vertically from a subsidiary string (reference string by default) according to a symmetrical (cubic) reverse curve mathematical function.

Alternatively a datum level may be used instead of the subsidiary string and the vertical offsets applied to this level.

Input

Graphics

IGDESIT.DAT, DES015, DES018, DES019

Add levelsAdd/amend levels	Curved vertical offset	Cubic reverse curve
Add comments to input log	Add comments to input log	Existing string label
Constant vertical offset	Cubic reverse curve	Subsidiary string label
Linear vertical offset	Circular reverse curve	Reference string label
Curved vertical offset	Biquadratic reverse curve	Datum level
Spline vertical offset		Start chainage / X coord
Constant crossfall		Start point no. / Y coord
Linear crossfall		Vertical offset at start
Curved crossfall		End chainage / X coord
Superelevation		End point no. / Y coord
Ext crossfall (2 strings)		Vertical offset at end

Linemode

Minor option 122

- \* Field 1 Reference string.
- Field 2 Subsidiary string (optional)
- \* Field 3 String to be amended.
- Field 4 Datum level (optional).
- Field 5 & 6 SPRD start.
- \* Field 7 Vertical offset required at start point.
- Field 8 & 9 SPRD end.
- \* Field 10 Vertical offset required at end point.

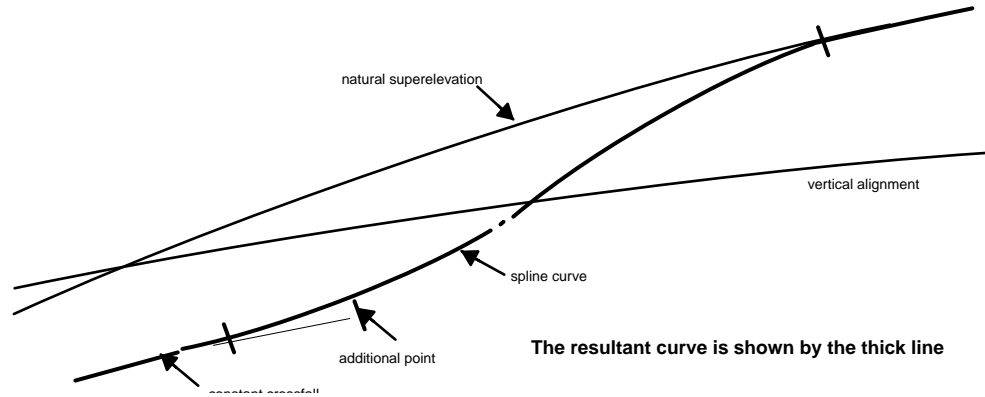
Minor option 123 Amend levels: spline curve offset

Amend the levels of a section of a string by the application of a spline.

The use of this minor option is primarily in conjunction with minor option 133 which applies natural superelevation to a string. Although the levels are dynamically correct, in certain areas the crossfall may be insufficient for drainage considerations which requires further modification of the levels to ensure adequate carriageway run-off.

Where the crossfall is less than the minimum required, options 120/130 are used to apply a constant crossfall over the relevant lengths. Option 123 is then used to apply a spline curve between the start or end of the constant crossfall and the naturally superelevation at the specified chainage.

The constant crossfall must be applied first and must extend one string point beyond the required application at both the start and end. This is necessary to permit the curve fitting routine to determine the instantaneous start and finish gradients required for the end points of the spline.



**Figure 8 - 40 Example - application of constant crossfall**

**Input**

**Graphics**

IGDESIT.DAT, DES002, DES015, DES022

<b>DESIGN options</b>	<b>Add levelsAdd/amend levels</b>	<b>Spline vertical offset</b>
Add comments to input log	Add comments to input log	Existing string label
Define system parameters	Constant vertical offset	Reference string label
Define linear units	Linear vertical offset	Start chainage / X coord
Add/amend string	Curved vertical offset	Start point no. / Y coord
Add levelsAdd/amend levels	Spline vertical offset	End chainage / X coord
Add M-string	Constant crossfall	End point no. / Y coord
Report displacements	Linear crossfall	
End DESIGN	Curved crossfall	
	Superelevation	
	Ext crossfall (2 strings)	

**Linemode**

**Minor option 123**

- \* Field 1 Reference string.
- Field 2 Subsidiary string (optional)
- Field 3 String to be amended.
- Field 5 & 6 SPRD start.
- Field 8 & 9 SPRD end.

Example

Figure 8 - 41 illustrates string OCL5 whose natural superelevation has been determined by option 133, over a length of road where the curvature has changed from left to right. Option 130 is used to apply constant carriageway crossfall at 2.5 per cent between chainage 340 and 500 and two option 123 applications are used to introduce the spline continuity.

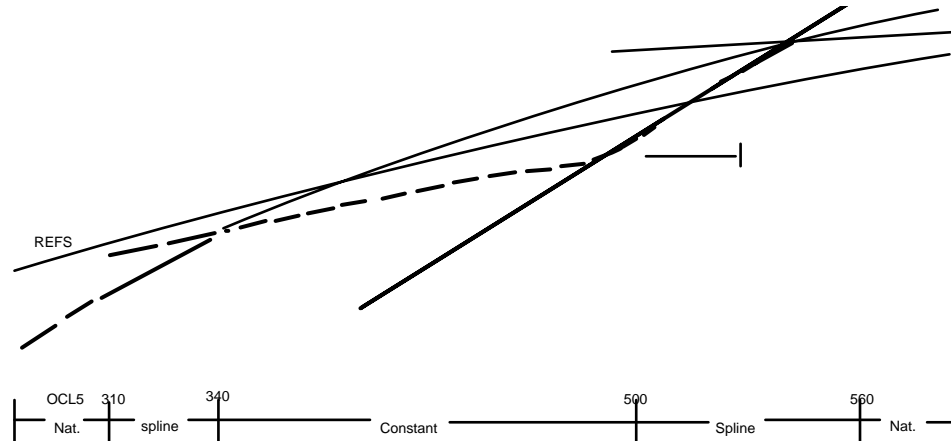


Figure 8 - 41 Example - option 123

```

DESIGN, SIMPLE DESIGN ROAD
  APPLY CONSTANT SUPERELEVATION TO STRING OCL5
  BETWEEN 340 AND 500
130, REFS, , 5=340.0, , -0.025, 500.0
  APPLY SPLINE SUPERELEVATION BETWEEN 310 340
  AND BETWEEN 500 TO 560
123, REFS, , OCL5, , 310.0, 8=340.0
123, REFS, , OCL5, , 500.0, 8=560.0
  
```

**Minor option 125 Amend levels: reverse circular curve offset**

Amend the levels of a section of string by vertical offsetting from an existing string according to a reverse circular curve formula.

This option must be preceded by an option 122 on which the start and end vertical offsets are left blank.

Input

Graphics

IGDESIT.DAT, DES018, DES020, DES021

Curved vertical offset	Circular reverse curve	Circular reverse curve
Add comments to input log	Existing string label	First arc length
Cubic reverse curve	Subsidiary string label	Vertical offset at start
Circular reverse curve	Reference string label	Second arc length
Biquadratic reverse curve	Datum level	Vertical offset at end
	Start chainage / X coord	
	Start point no. / Y coord	
	End chainage / X coord	
	End point no. / Y coord	

Linemode

Minor option 122

- \* Field 1 Reference string
- Field 2 Subsidiary string (optional)
- \* Field 3 String to be amended.
- Field 4 Datum level (optional)
- Field 5 & 6 SPRD start
- Field 8 & 9 SPRD end

Minor option 125

- \* Field 5 Length of first arc
- \* Field 7 Vertical offset to be applied at start
- \* Field 8 Length of second arc
- \* Field 10 Vertical offset to be applied at end

Example

```
DESIGN, NEW THORNBROUGH
122,M006,,M002,5=200,8=500
125,5=100,, -0.37,100,, -1.53
999
```

## Minor option 126 Amend levels: biquadratic reverse curve offset

Amend the levels of a section of string by vertical offsetting from an existing string or from a defined level datum.

This minor option will amend the levels in a section of an existing string between normals erected on a reference string. The levels are derived by offsetting vertically from a subsidiary string (reference string by default) according to a biquadratic reverse curve mathematical function.

Alternatively a datum level may be used instead of the subsidiary string and the vertical offsets applied to this level.

### Input

### Graphics

IGDESIT.DAT, DES018, DES060

Curved vertical offset	Biquadratic reverse curve
Add comments to input log	Existing string label
Cubic reverse curve	Subsidiary string label
Circular reverse curve	Reference string label
Biquadratic reverse curve	Datum level
	Start chainage / X coord
	Start point no. / Y coord
	Vertical offset at start
	End chainage / X coord
	End point no. / Y coord
	Vertical offset at end

### Linemode

#### Minor option 126

- \* Field 1 Reference string.
- Field 2 Subsidiary string (optional)
- \* Field 3 String to be amended.
- Field 4 Datum level (optional).
- Field 5 & 6 SPRD start.
- \* Field 7 Vertical offset required at start point.
- Field 8 & 9 SPRD end.
- \* Field 10 Vertical offset required at end point.



## Minor option 130 Amend levels: constant crossfall

Amend the levels of a section of a string by the application of crossfall relative to another string.

This minor option will amend the levels in a section of an existing string between normals erected on a reference string. The levels are derived by the application of crossfall relative to a subsidiary string according to various mathematical functions.

### Input

### Graphics

IGDESIT.DAT, DES002, DES015, DES023

DESIGN options	Add levelsAdd/amend levels	Constant crossfall
Add comments to input log	Add comments to input log	Existing string label
Define system parameters	Constant vertical offset	Subsidiary string label
Define linear units	Linear vertical offset	Reference string label
Add/amend string	Curved vertical offset	Start chainage / X coord
Add levelsAdd/amend levels	Spline vertical offset	Start point no. / Y coord
Add M-string	Constant crossfall	Crossfall
Report displacements	Linear crossfall	End chainage / X coord
End DESIGN	Curved crossfall	End point no. / Y coord
	Superelevation	
	Ext crossfall (2 strings)	

### Linemode

#### Minor option 130

- \* Field 1 Reference string.
- Field 2 Subsidiary string (optional)
- \* Field 3 String to be amended.
- Field 5 & 6 SPRD start.
- \* Field 7 Constant crossfall to be applied
- Field 8 & 9 SPRD end.

## Minor option 131 Amend levels: linear crossfall

Amend the levels of a section of a string by the application of crossfall relative to another string.

This minor option will amend the levels in a section of an existing string between normals erected on a reference string. The levels are derived by the application of crossfall relative to a subsidiary string according to various mathematical functions.

**Input**

Graphics

IGDESIT.DAT, DES002, DES015, DES024

DESIGN options	Add levelsAdd/amend levels	Linear crossfall
Add comments to input log	Add comments to input log	Existing string label
Define system parameters	Constant vertical offset	Subsidiary string label
Define linear units	Linear vertical offset	Reference string label
Add/amend string	Curved vertical offset	Start chainage / X coord
Add levelsAdd/amend levels	Spline vertical offset	Start point no. / Y coord
Add M-string	Constant crossfall	Crossfall at start
Report displacements	Linear crossfall	End chainage / X coord
End DESIGN	Curved crossfall	End point no. / Y coord
	Superelevation	Crossfall at end
	Ext crossfall (2 strings)	

Linemode

**Minor option 131**

- \* Field 1 Reference string.
- Field 2 Subsidiary string (optional)
- \* Field 3 String to be amended.
- Field 5 & 6 SPRD start.
- \* Field 7 Crossfall required at start point
- Field 8 & 9 SPRD end.
- Field 10 Crossfall required at end.

**Minor option 132 Amend levels: symmetrical reverse curve crossfall**

Amend the levels of a section of a string by the application of crossfall relative to another string.

This minor option will amend the levels in a section of an existing string between normals erected on a reference string. The levels are derived by

the application of crossfall relative to a subsidiary string according to various mathematical functions.

**Input**

**Graphics**

**IGDESIT.DAT, DES015, DES025, DES026**

<b>Add levels</b> Add/amend levels	<b>Curved crossfall</b>	<b>Cubic reverse curve</b>
Add comments to input log	Add comments to input log	Existing string label
Constant vertical offset	Cubic reverse curve	Subsidiary string label
Linear vertical offset	Circular reverse curve	Reference string label
Curved vertical offset	Biquadratic reverse curve	Start chainage / X coord
Spline vertical offset		Start point no. / Y coord
Constant crossfall		Crossfall at start
Linear crossfall		End chainage / X coord
Curved crossfall		End point no. / Y coord
Superelevation		Crossfall at end
Ext crossfall (2 strings)		

**Linemode**

**Minor option 132**

- \* Field 1      Reference string.
- Field 2      Subsidiary string (optional)
- \* Field 3      String to be amended.
- Field 5 & 6   SPRD start.
- Field 7      Crossfall required at start point.
- Field 8 & 9   SPRD end.
- \* Field 10     Crossfall required at end.

Example

The example shows the use of option 132 for the application of reverse curves superlevation.

```
DESIGN,NEW THORNBROUGH
  APPLY SUPERELEVATION BY REVERSE CURVE TO OCL1 WITH
  REFERENCE TO ICL1 BETWEEN CHAINAGES 0.0 AND 340.0
  ON MAST
132,MAST,ICL1,OCL1,5=0.0,, -0.025,340,, 0.025
```

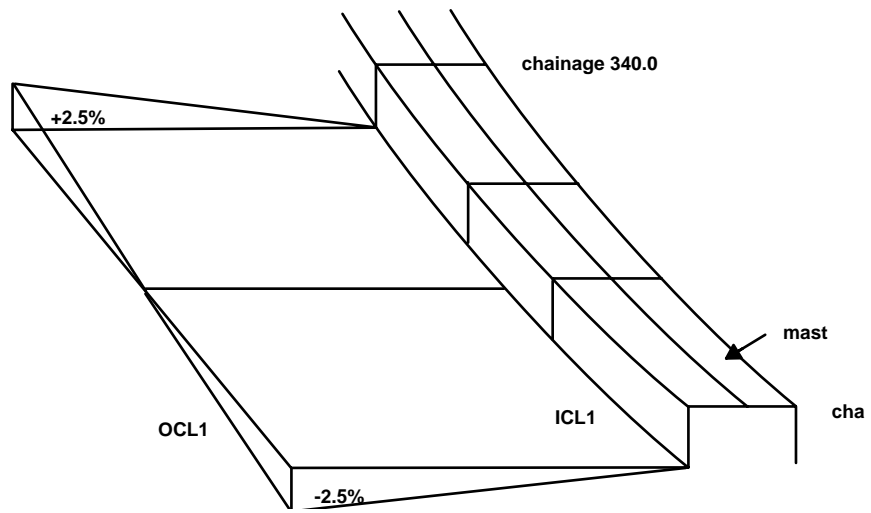


Figure 8 - 42 Example - reverse curve superlevation

Note that this option will apply superlevation to a string irrespective of whether the string is parallel to the reference or subsidiary string.

Minor option 133 Amend levels: superlevation

Amend the levels of a section of a string by the application of natural superlevation relative to another string.

Natural or theoretical superlevation is defined as the amount of superlevation required to account for 40% of the centripetal force on a vehicle travelling around a horizontal curve and is determined from the formula.

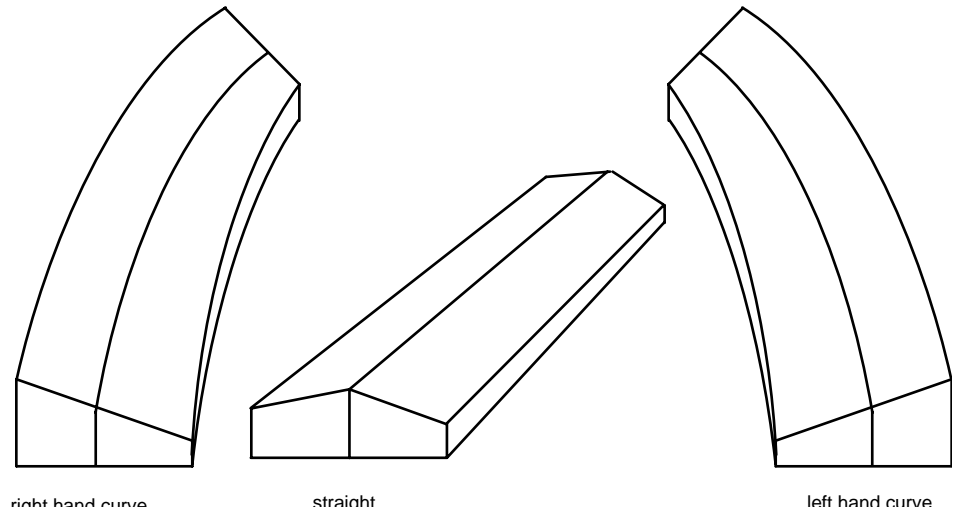
$$\frac{V^2}{K.R.} \quad \% \text{ percentage crossfall}$$

The default value of K is 2.828 with V measured in km/h.

The reference string must always be a master alignment and if a subsidiary string for the level reference then it should be parallel to the reference string for the theoretical radius to remain true.

The superlevation is calculated and the level difference applied appropriately to the hand of the curve. This applies even when the

minimum percentage crossfall is invoked. If the horizontal element is a straight, giving a theoretical superelevation of zero the minimum percentage crossfall is applied so that the level is lower than the reference string level.



**Figure 8 - 43 Example - superelevation**

Where the natural superelevation of a point falls below the absolute value of the minimum defined the minimum superelevation is used in preference. Users should be aware that this may cause an anomalous step in the vertical profile.

**Input**

**Graphics**

**IGDESIT.DAT, DES002, DES015, DES029**

<b>DESIGN options</b>	<b>Add levelsAdd/amend levels</b>	<b>Superelevation</b>
Add comments to input log	Add comments to input log	Existing string label
Define system parameters	Constant vertical offset	Subsidiary string label
Define linear units	Linear vertical offset	Reference string label
Add/amend string	Curved vertical offset	Design speed
Add levelsAdd/amend levels	Spline vertical offset	Start chainage / X coord
Add M-string	Constant crossfall	Start point no. / Y coord
Report displacements	Linear crossfall	Minimum crossfall
End DESIGN	Curved crossfall	End chainage / X coord
	Superelevation	End point no. / Y coord
	Ext crossfall (2 strings)	Maximum crossfall

Linemode

Minor option 133

- \* Field 1      Reference string.
- Field 2      Subsidiary string (optional)
- \* Field 3      String to be amended.
- \* Field 4      Design Speed (km/h) or  $V^2/K$  if the constant K is different from the default or if imperial units are being used.
- Field 5 & 6   SPRD start.
- Field 7      Minimum percentage crossfall - optional.  
This value is used to determine the superelevation if the absolute value of the calculated superelevation is less than this minimum amount. (1 in 40 = 0.025).
- Field 8 & 9   SPRD end.
- Field 10     Maximum percentage crossfall - optional  
This value is used to determine the superelevation if the absolute value of the calculated superelevation is greater than this maximum amount (1 in 14 = 0.07).

The **French design rules** for the application of superelevation may be automatically applied by setting field 1 = FDES on minor option 017. All fields of 133 have the same significance as above. Field 4 must be a design speed for French design rules.

Example

```
017, FDES
133, MAST, CINR, CRIG, 120, 100, , -0.025, 200, , 0.07
133, MAST, INL, CLEF, 120, 100, , -0.025, 200, , 0.07
```

would be interpreted as:

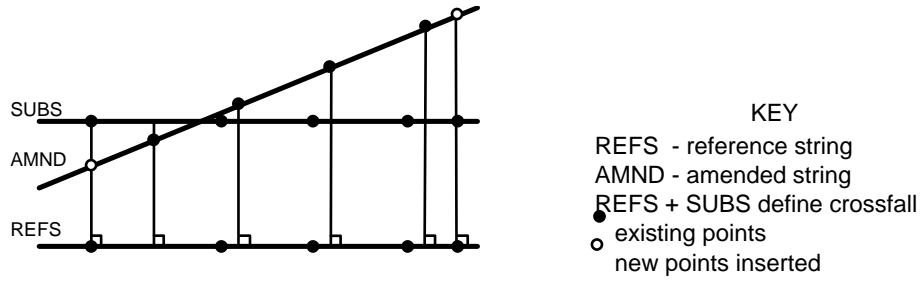
Apply the French method of superelevation to the string CRIG between chainages 100 and 200 on the reference string MAST; The subsidiary channel string to be used is CINR and the design speed is 120 km/h, the minimum crossfall is -2.5% and the maximum is 7%.

Having adjusted the levels on string CRIG do the similar operation to string CLEF based on CINL.

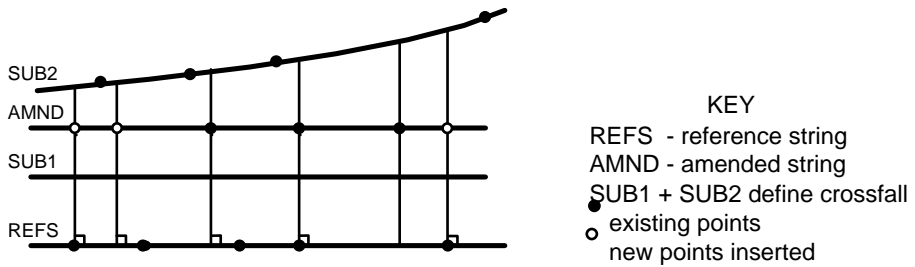
## Minor option 134    Amend levels: extend crossfall (2 strings)

Amend the levels of a section of string by applying the crossfall between two other strings.

This minor option will amend the levels in a section of an existing string between normals erected on a reference string. The levels are derived by applying the crossfall determined along the normals between the reference and subsidiary strings. The string to be amended may lie between or outside of the reference or subsidiary strings or cross these strings. Optionally a constant vertical offset may also be applied.



**Figure 8 - 44 Example 1 - option 134**



**Figure 8 - 45 Example 2 - option 134**

**Input**

**Graphics**

IGDESIT.DAT, DES002, DES015, DES030

<b>DESIGN options</b>	<b>Add levelsAdd/amend levels</b>	<b>Ext crossfall (2 strings)</b>
Add comments to input log	Add comments to input log	Existing string label
Define system parameters	Constant vertical offset	Subsidiary string label
Define linear units	Linear vertical offset	Reference string label
Add/amend string	Curved vertical offset	Start chainage / X coord
Add levelsAdd/amend levels	Spline vertical offset	Start point no. / Y coord
Add M-string	Constant crossfall	End chainage / X coord
Report displacements	Linear crossfall	End point no. / Y coord
End DESIGN	Curved crossfall	
	Superelevation	
	Ext crossfall (2 strings)	

IGDESIT.DAT, DES002, DES015, DES031

DESIGN options	Add levelsAdd/amend levels	Ext (slope defined by 104)
Add comments to input log	Ext (slope defined by 104)	Existing string label
Define system parameters	Tilted plane	Reference string label
Define linear units	End DESIGN	Start chainage / X coord
Add/amend string		Start point no. / Y coord
Add levelsAdd/amend levels		End chainage / X coord
Add M-string		End point no. / Y coord
Report displacements		String 1 defining slope
End DESIGN		String 2 defining slope
		Vertical offset

Linemode

Minor option 134

- \* Field 1      Reference string.
- Field 2      Subsidiary string.  
If field 2 is coded the slope is calculated between the reference string and this string.  
If field 2 is left blank then a complementary option 104 must follow to define the strings dictating the slope.
- \* Field 3      String to be amended.
- Field 5 & 6    SPRD start.
- Field 8 & 9    SPRD end.

Minor option 104

(Only required if field 2 on option 134 is left blank.)

- Field 2      First string defining slope (SUB1).
- Field 3      Second string defining slope (SUB2).
- Field 4      Vertical offset to be applied.

Example

```
134 ,M003 , , CCL2
104 , , E101 ,OC01
```

If the reference string also acts as one of the strings from which the slope is extended, a complementary 104 is unnecessary.

```
134 ,M003 ,OC01 , CCL2
would have the same effect as:
```



134 , M003 , , CCL2  
104 , , M003 , OC01

## Minor option 135 Amend levels: reverse circular curve crossfall

Amend the levels of a section of string by vertical crossfall from an existing string according to a reverse circular curve formula.

This option must be preceded by an option 132 on which the start and end vertical crossfalls are left blank.

### Input

### Graphics

IGDESIT.DAT, DES025, DES015, DES024

Curved crossfall	Circular reverse curve	Circular reverse curve
Add comments to input log	Existing string label	First arc length
Cubic reverse curve	Subsidiary string label	Start crossfall
Circular reverse curve	Reference string label	Second arc length
Biquadratic reverse curve	Start chainage / X coord	End crossfall
	Start point no. / Y coord	
	End chainage / X coord	
	End point no. / Y coord	

### Linemode

#### Minor option 132

- \* Field 1 Reference string
- Field 2 Subsidiary string (optional)
- \* Field 3 String to be amended.
- Field 5 & 6 SPRD start
- Field 8 & 9 SPRD end

#### Minor option 135

- Field 5 Length of first arc
- Field 7 Vertical crossfall to be applied at start
- Field 8 Length of second arc
- Field 10 Vertical crossfall to be applied at end

Example

```
DESIGN, NEWTHORNBOROUGH
132, M006, , M002, 5=2000, 8=500
135, 5=100, , -037, 100, , -1.53
999
```

**Minor option 136 Amend levels: biquadratic reverse curve crossfall**

Amend the levels of a section of a string by the application of crossfall relative to another string.

This minor option will amend the levels in a section of an existing string between normals erected on a reference string. The levels are derived by the application of crossfall relative to a subsidiary string according to a biquadratic reverse curve function.

Input

Graphics

IGDESIT.DAT, DES015, DES025, DES061

Add levelsAdd/amend levels	Curved crossfall	Biquadratic reverse curve
Add comments to input log	Add comments to input log	Existing string label
Constant vertical offset	Cubic reverse curve	Subsidiary string label
Linear vertical offset	Circular reverse curve	Reference string label
Curved vertical offset	Biquadratic reverse curve	Start chainage / X coord
Spline vertical offset		Start point no. / Y coord
Constant crossfall		Crossfall at start
Linear crossfall		End chainage / X coord
Curved crossfall		End point no. / Y coord
Superelevation		Crossfall at end
Ext crossfall (2 strings)		

Linemode

Minor option 136

- \* Field 1 Reference string.
- Field 2 Subsidiary string (optional)
- \* Field 3 String to be amended.
- Field 5 & 6 SPRD start.
- \* Field 7 Crossfall required at start point.
- Field 8 & 9 SPRD end.

Field 10      Crossfall required at end.

## Minor option 099      Invoke the simplified design process

### Simple design process

All design options in the range 100 - 135 may be used as qualifying options for minor option 099. The process is appropriate to the design of regular profiles or standard templates.

The full extent of the string to be designed is defined relative to the reference and subsidiary strings. The variations within the string, both horizontally and vertically are then specified to produce the completed string. There is no difference between the string designed by this method and the full comprehensive method, and the string may be subsequently amended by the existing Design options.

The simple design process is invoked by option 099 defining the reference, subsidiary and new strings together with standard point reference data for the extent of the application. The associated minor options, which may be any of the existing standard options (100-135) then define the intermediate extents and the offsets or crossfalls, but do not re-define the string labels. Indeed if any of the string labels are change or re-defined this indicates that the current simple design process is at an end and the string is generated in the model.

### Input

#### Linemode

#### Minor option 099

- \* Field 1      Reference string.
- Field 2      Subsidiary string (optional)
- \* Field 3      New, extended or amended string.
- Field 5 & 6    Global start point. SPRD. This point defines the lower extent of the range of the following options.
- Field 8 & 9    Global end point. SPRD.

The following options may be any of the existing range (100 -139) but fields 1 to 3 must be left blank. All other fields are coded as described under the appropriate option.

The options may be run in any sequence but the horizontal options should naturally precede the vertical options.

Should another option 099 be invoked or an option with any fields 1 to 3 be coded, the string is deemed complete.

If the string defined as the new string already exists in the model it is amended but note that if the string was not created relative to the defined reference string the stored plan coordinates may be change. This is because points are generated which lie on normals from the points on the

reference string, and normals are not dropped from points on the new string to the reference string.

### Example

The example shows the inclusion of a lay-by in the Thornbrough Interchange

```
DESIGN, NEW THORNBROUGH
099,M003,E101,OCO1
100,4=0,7=-27.0
100,5=5250,7=-37.0,5300
101,5=5230,7=-27.0,5250,, -37.0
101,5=5300,7=-37.0,5320,, -27.0
999
```

## Minor option 140 Add M-string

Generate a six dimensional master alignment string in a horizontal plane, described by a circle, option 141 or defined by a straight line, option 142.

Minor option 140 provides the initial data for minor options 141 and 142 and the string created from both options has six dimensions. The circular string created by option 141 must always be specified by a chainage which may be different to the chainage of the initial point defining the string.

### Input

#### Graphics

◇ *This option is automatically included in options 141 and 142 when invoked in graphics.*

#### Linemode

### Initial data for options 141 and 142

#### Minor option 140

- \* Field 3      New string label - must start with M
  - \* Field 4      Chainage interval
  - Field 5      Start chainage. If blank it is assumed to be the same as the chainage of the initial point.
  - Field 6      Chainage of initial point. If blank it is assumed to be zero.
- The following fields are only coded for option 141
- Field 7      Tolerance for straight line fitChord-to-arc tolerance ( (The default chord-to-arc tolerance is determined by the variable AHDETOLR in the parameter file. )default value 0.1)
  - \* Field 8 & 9   X and Y coordinates of circle centre
  - \* Field 10     Circle radius, +ve for right hand or clockwise and -ve, for left hand or anti-clockwise curve.

## Minor option 141 Create curve

This option generates a string of points on a circle.

The initial and final points on the string are defined where a line emanating from the circle centre intersects the circle and the line may be specified by a bearing or by a further pair of coordinates.

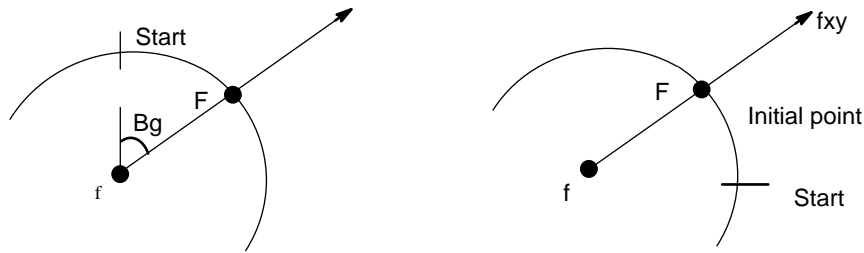


Figure 8 - 46 generation of points on a circle

The end of the string may also be defined by an end chainage.

The initial and final points may also be defined from existing strings instead of absolute x,y values.

### Input

### Graphics

IGDESIT.DAT, DES034, DES035, DES036

Add M-string	Create curve XY - XY	Create curve XY - XY
Add comments to input log	New string label	Z coordinate
Create curve XY - XY	Chainage interval	Start X coordinate
Create curve XY - BRG	Start point	Start Y coordinate
Create curve BRG - XY	Initial point chainage	End X coordinate
Create curve BRG - BRG	Straight line tolerance	End Y coordinate
Create straight XY - XY	Centre X coordinate	End chainage
Create straight XY - BRG	Centre Y coordinate	
Create circular	Circle radius	
Create three centre curve		
End DESIGN		

**IGDESIT.DAT, DES034 , DES037, DES038**

Add M-string	Create curve XY - BRG	Create curve XY - BRG
Add comments to input log	New string label	Z coordinate
Create curve XY - XY	Chainage interval	Start X coordinate
Create curve XY - BRG	Start point	Start Y coordinate
Create curve BRG - XY	Initial point chainage	End bearing
Create curve BRG - BRG	Straight line tolerance	End chainage
Create straight XY - XY	Centre X coordinate	
Create straight XY - BRG	Centre Y coordinate	
Create circular	Circle radius	
Create three centre curve		
End DESIGN		

**IGDESIT.DAT, DES034, DES040, DES040**

Add M-string	Create curve BRG - XY	Create curve BRG - XY
Add comments to input log	New string label	Z coordinate
Create curve XY - XY	Chainage interval	Start bearing
Create curve XY - BRG	Start point	End X coordinate
Create curve BRG - XY	Initial point chainage	End Y coordinate
Create curve BRG - BRG	Straight line tolerance	End chainage
Create straight XY - XY	Centre X coordinate	
Create straight XY - BRG	Centre Y coordinate	
Create circular	Circle radius	
Create three centre curve		
End DESIGN		

**IGDESIT.DAT, DES034, DES041, DES042**

Add M-string	Create curve BRG - BRG	Create curve BRG - BRG
Add comments to input log	New string label	Z coordinate
Create curve XY - XY	Chainage interval	Start bearing
Create curve XY - BRG	Start point	End bearing
Create curve BRG - XY	Initial point chainage	End chainage
Create curve BRG - BRG	Straight line tolerance	
Create straight XY - XY	Centre X coordinate	
Create straight XY - BRG	Centre Y coordinate	
Create circular	Circle radius	
Create three centre curve		
End DESIGN		

**Linemode**

This option generates a string of points on a circle and must always be preceded by option 140.

**Minor option 141**

- Field 1 String to define initial point using SPRD in fields 5 & 6
- Field 2 String to define final point using SPRD in fields 8 & 9
- Field 4 Level of string. If blank the level is set to -999.0
- \* Field 5 Initial Point easting or bearing (centesimal) or SPRD if field 1 coded
- \* Field 6 Initial Point northing (optional) or SPRD if field 1 coded
- \* Field 8 End Point easting or bearing (centesimal) or SPRD if field 2 coded
- \* Field 9 End Point northing (optional) or SPRD if field 2 coded
- \* Field 10 End chainage (optional)

**Minor option 142 Create straight**

This option generates a string of points on a straight line. The straight may be defined by a point and bearing or two points. An end chainage is required for the first situation but may be omitted when two points are defined whence the string will end at the second point. The initial and final points may also be defined from existing strings instead of absolute x, y values.

Input

Graphics

IGDESIT.DAT, DES034, DES043, DES044

Add M-string	Create straight XY - XY	Create straight XY - XY
Add comments to input log	New M-string label	Z coordinate
Create curve XY - XY	Chainage interval	Start X coordinate
Create curve XY - BRG	Start point	Start Y coordinate
Create curve BRG - XY	Initial point chainage	End X coordinate
Create curve BRG - BRG		End Y coordinate
Create straight XY - XY		End chainage
Create straight XY - BRG		
Create circular		
Create three centre curve		
End DESIGN		

IGDESIT.DAT, DES034, DES045, DES046

Add M-string	Create straight XY - BRG	Create straight XY - BRG
Add comments to input log	New M-string label	Z coordinate
Create curve XY - XY	Chainage interval	Start X coordinate
Create curve XY - BRG	Start point	Start Y coordinate
Create curve BRG - XY	Initial point chainage	Bearing
Create curve BRG - BRG		End chainage
Create straight XY - XY		
Create straight XY - BRG		
Create circular		
Create three centre curve		
End DESIGN		



Linemode

This option generates a string of points on a straight line and must always be preceded by option 140.

Minor option 142

- \* Field 1 String to define initial point using SPRD in field 5 & 6
- \* Field 2 String to define final point using SPRD in field 8 & 9
- Field 4 Level of string. If blank the level is set to -999.0
- Field 5 Initial Point easting or SPRD if field 1 coded
- Field 6 Initial Point northing or SPRD if field 1 coded
- \* Field 8 End Point easting or bearing (centesimal) or SPRD if field 2 coded
- Field 9 End Point northing (optional) or SPRD if field 2 coded
- Field 10 End chainage. Essential if bearing specified in field 8 otherwise optional.

A final special case is catered for by the following combination on the 142 option.

- Field 1 Reference string
- Field 5 & 6 SPRD on reference string
- \* Field 8 Bearing adjustment clockwise relative to reference string (default-0) -centesimal
- Field 10 End chainage

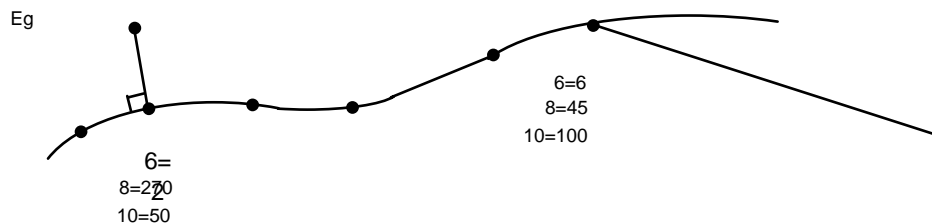


Figure 8 - 47 Example - option 142

Example

The following input illustrates the use of the options.

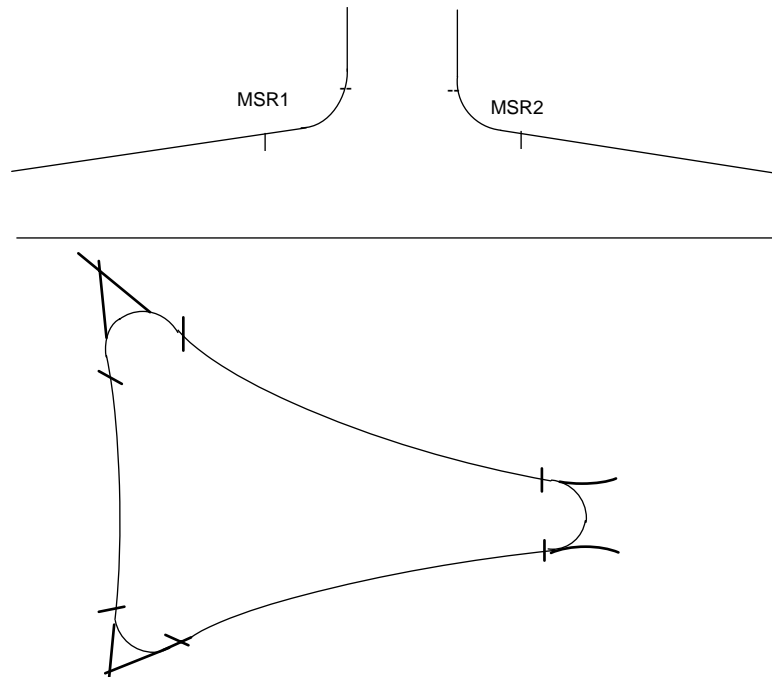
```

DESIGN. NEW THORNBOROUGH
  GENERATE A CIRCULAR STRING
140,3=M007,20.0,,637.5,,3482.80,4622.75,-40.0
141,5=3494.0,4637.0,,317.2
  GENERATE A STRAIGHT LINE STRING
140,3=M008,20.0
142,4=126.4,5267.8,3978.2,,58.286,10=527.0
  
```

## Minor option 145 Create circular

Generate a circular master alignment between two strings.

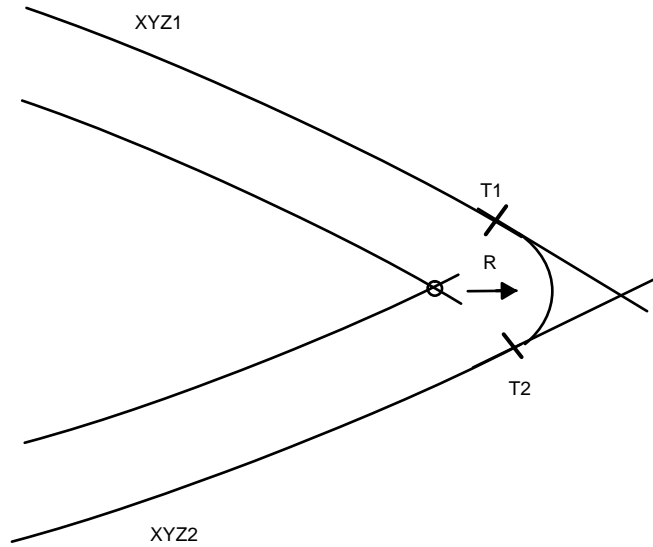
This minor option allows a circular arc of specified radius to be located between two strings. The main application will be for detail design as illustrated in the following examples.



**Figure 8 - 48 Examples - circular master alignment**

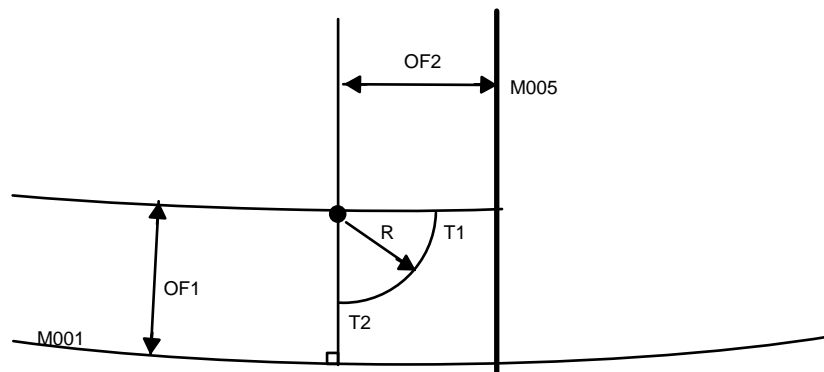
The option generates the required circular arc as a master alignment and provides details of the generating strings for subsequent editing and for creating the vertical alignment of the new string.

The theory for calculation is that imaginary strings are designed at specified offsets from the defined radius, which is generated between the perpendiculars from the centre to the defined strings. If the offsets and radius are the same this will be the two tangent points as illustrated below.



**Figure 8 - 49 Example - circular alignment between perpendiculars**

A curve may be generated remotely from the defined strings if the offsets are different to the radius.



**Figure 8 - 50 Example - Offset not equal to radius**

The hand of the generated curve is defined by the radius and it proceeds from the first specified string. The offsets must be specified as +ve (right) and -ve (left) relative to the direction of the strings to correctly locate the radius. Where there is more than one intersection of the strings approximate coordinates of the arc centre are necessary to identify the required solution.

The option can also be used in a limited form as a Report option for determining the intersection of two offset lines. This application is described in Chapter 4.

Input

Graphics

IGDESIT.DAT, DES002, DES034, DES047

DESIGN options	Add M-string	Create circular
Add comments to input log	Add comments to input log	New M-string label
Define system parameters	Create curve XY - XY	1st string label
Define linear units	Create curve XY - BRG	2nd string label
Add/amend string	Create curve BRG - XY	M-string radius
Add levelsAdd/amend levels	Create curve BRG - BRG	Chainage interval
Add M-string	Create straight XY - XY	Point 1 chainage
Report displacements	Create straight XY - BRG	Centre offset from str 1
End DESIGN	Create circular	Centre X coordinate
	Create three centre curve	Centre Y coordinate
	End DESIGN	Centre offset from str 2

Linemode

Minor option 145

- \* Field 1 First string label.
- \* Field 2 Second string label.
- \* Field 3 String to be created which must start with M.  
If this field is omitted the option will be considered simply as a Report option.
- \* Field 4 Radius of string to be created. For left hand curve code -ve radius.
- \* Field 5 Chainage interval.  
If a negative chainage interval is specified, the points where the new string is tangential to the first and second strings will not be added to the first and second strings.
- Field 6 Chainage of initial point. This is the point at which the string is tangential to the string defined in field 1. (Point T1 in Figure 8 - 50).
- \* Field 7 Offset of element centre from first string.
- Field 8 & 9 Approximate coordinates of element centre (optional).
- Field 10 Offset of element centre from second string.  
If omitted the value as coded in field 7 will be assumed. This will normally have the same absolute value as field 7 but depending on the direction of the string it may be of different sign.

- ◇ This option will may create an additional point on each reference string to ensure that, should the model subsequently be triangulated and passed to the MOSS Visualisation System for rendering, no anomalies exist in the triangulated surfaces. These points can be omitted by specifying a negative chainage in field 4.
- ◇ Points are not added to 5D interface strings.
- ◇ If triangulation and visualisation are not proposed, the additional points may be deleted by specifying a negative chainage interval in field 4..

## Output

The output provides details of the tangent points and centre of the generated arc together with the tangent point details on the originating strings.

## Example

```

DESIGN, NEW THORNBROUGH
  CONSIDER THE BRIDGE AREA
  DESIGN STRINGS M103,M108,M107,M108
  USING DESIGN OPTION 145 TO TAILOR THE INTERFACES
  INTO ONE ANOTHER
  NOTE THAT THE OFFSETS ARE 24.99 RATHER THAN 25.0
  SO AS TO ENSURE INTERSECTIONS WITH LATER EDITING
  145, IXX1, IXX2, M103, -25.0, 1, 0, -24.99, 10=24.99
  999
  
```

The example illustrates the use of the option in the Thornbrough Interchange design to join two interface strings.

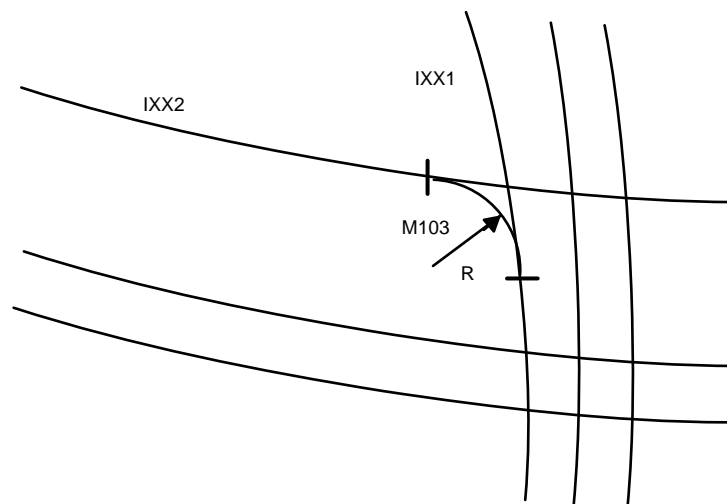


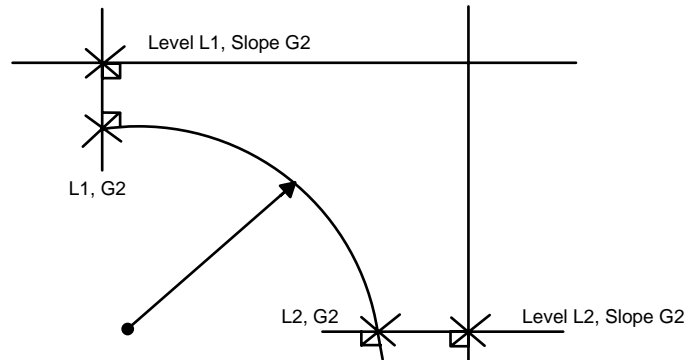
Figure 8 - 51 Example - option 145

## Design considerations

The minor options allows the introduction of circular arcs for design detailing. If it is intended to trim the originating strings back to the tangent

points by specifying the intersection, the radius of the new arc should be specified slightly larger (0.01) than the specified offset to locate the centre. This is illustrated in the previous example.

Where slope and level information is available at both tangent points levels are introduced along the generated string. These are calculated from a vertical cubic spline fitted between the two end points with grades derived from the tangencing strings. If the generated string is not coincident with the two other strings then the associated information is found by taking normals.



**Figure 8 - 52 Example - vertical cubic spline**

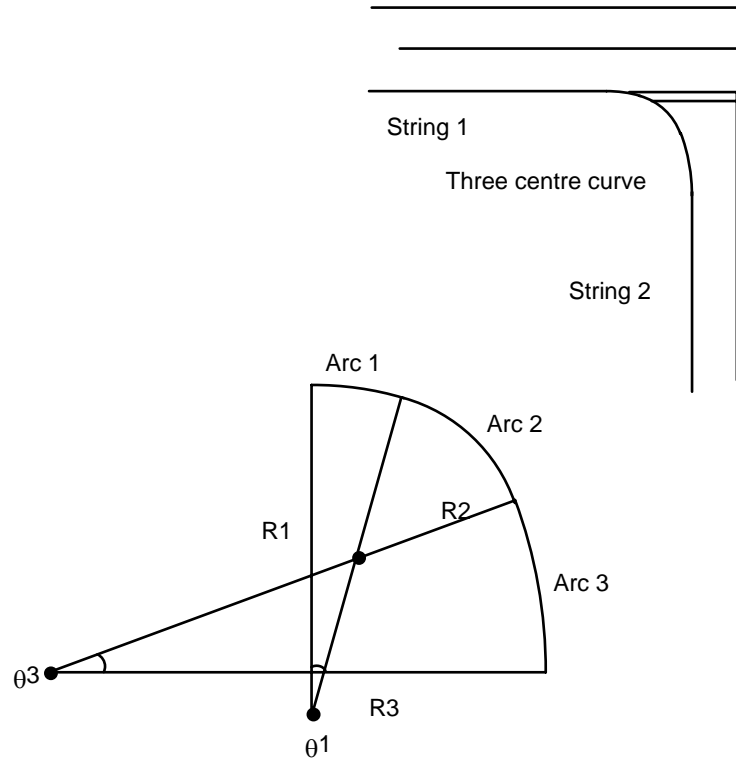
The inclusion of level information is automatic and no extra data is needed. However, if the levels so generated are unsatisfactory then they may be subsequently amended. For situations such as traffic islands, the DESIGN 152 option may be appropriate; or if the surrounding design detail is well defined, the new string, may be run as a long section (SECTION 171) to determine its own levels.

### Minor option 146/147 Create three centre curve

Generate a three centre curve and insert it between two strings.

Three centre curves are commonly used in junction design. The radius of the middle arc of the curve is defined by the user, and from this a ratio is used to calculate the radii of the outer arcs. The length of each outer arc is determined by a stored subtended angle, or is specified by the user.

The default ratio and subtended angles of the outer arcs are stored in the parameter file.



$R1 : R2 : R3 = 2 : 1 : 3$

$\theta 1$  and  $\theta 3$  are set in the parameter file

Figure 8 - 53 Three centre curve

Input

Graphics

IGDESIT.DAT, DES002, DES062, DES063

Add M-string	Create three centre curve	Create three centre curve
Add comments to input log	New M-string label	Radius of arc 2
Create curve XY - XY	1st string label	Radius of arc 1
Create curve XY - BRG	2nd string label	Angle of arc 1
Create curve BRG - XY	Radius of arc 2	Length of arc 1
Create curve BRG - BRG	Chainage interval	Radius of arc 3
Create straight XY - XY	Point 1 chainage	Angle of arc 3
Create straight XY - BRG	Offset from string 1 (T)	Length of arc 3
Create circular	Arc 2 X coordinate	
Create three centre curve	Arc 2 Y coordinate	
End DESIGN	Offset from string 2 (T)	

Linemode

Minor option 146

- \* Field 1 First string label
  - \* Field 2 Second string label
  - \* Field 3 New master string label
  - \* Field 4 Radius of arc 2  
The radius should be coded negative for a left hand arc and positive for a right hand arc.
  - \* Field 5 Chainage interval along the new string  
Field 6 Chainage of initial point (default 0).  
This is the point at which the new string is tangential to the first string.
  - \* Field 7 Location of new string relative to the first string  
-1 New string is to the left.  
1 New string is to the right.
  - Field 8 Approximate X coordinate of the centre of arc 2
  - Field 9 Approximate Y coordinate of the centre of arc 2
  - \* Field 10 Location of new string relative to the second string  
-1 New string is to the left.  
1 New string is to the right.
- ◇ *This option may create an additional point on each reference string to ensure that, should the model subsequently be triangulated and passed to the MOSS Visualisation System for rendering, no anomalies exist in the triangulated surfaces.*
- ◇ *Points are not added to 5D interface strings.*
- ◇ *If triangulation and visualisation are not proposed, the additional points may be deleted.*

Minor option 147

- Field 4 Radius of arc 1  
By default, the parameter file ratio is used to calculate this radius from the radius of arc 2.
- Field 5 Subtended angle of arc 1  
By default, the angle stored in the parameter file is used.
- Field 6 Length of arc 1  
If specified, this length overrides the subtended angle in Field 5.
- Field 7 Radius of arc 3  
By default, the parameter file ratio is used to calculate this radius from the radius of arc 2.
- Field 8 Subtended angle of arc 3  
By default, the angle stored in the parameter file is used.



- Field 9      Length of arc 3  
If specified, this length overrides the subtended angle in Field 8.
- ◇ *All radii should be specified with the same sign, ie, negative for a left hand arc and positive for a right hand arc.*
  - ◇ *If no field data is specified for minor option 147, all the default values are used.*

### Example 1

A three centre curve MARC is designed to the right of string C001 and to the left of string C002. All the fields in minor option 147 are blank and so all the default values are taken from the parameter file.

```
DESIGN, DESIGN MODEL
146, C001, C002, MARC, 8, 1, 0, 1, 10=-1
147
999
```

### Example 2

A three centre curve MARC is designed to the left of both C001 and C002. The default radii of arcs 1 and 3 have been overridden and specified as 12m and 20m respectively. Arc 3 is given an arc length of 5m rather than the subtended angle given in the parameter file.

```
DESIGN, DESIGN MODEL
146, C001, C002, MARC, -8, 1, 0, -1, 10=-1
147, 4=-12, 7=-20, 9=5
999
```

## Minor option 152    Tilted plane

Determine the levels of a string defined in plan which lies on a tilted plane surface.

Input

Graphics

IGDESIT.DAT, DES015, DES032, DES033

Add levelsAdd/amend levels	Tilted plane	Tilted plane
Ext (slope defined by 104)	Existing string label	Point 1 X coordinate
Tilted plane	Reference string label	Point 1 Y coordinate
End DESIGN	Start chainage / X coord	Point 1 Z coordinate
	Start point no. / Y coord	Point 2 X coordinate
	End chainage / X coord	Point 2 Y coordinate
	End point no. / Y coord	Point 2 Z coordinate
		Point 3 X coordinate
		Point 3 Y coordinate
		Point 3 Z coordinate

Linemode

The tilted plane is defined by three points of known coordinates and level. The volume of data requires three 152 options. The first record specifies the string for which the levels are to be determined and the limits for the calculation, either on the string itself or between normals erected from a reference string. The second and third records specify the three points on the plane.

**Type 1**

Minor option 152

- Field 1 Reference string.
- \* Field 3 String to be amended.
- Field 5 & 6 SPRD start.
- Field 8 & 9 SPRD end.

**Type 2 - two required**

Minor option 152

- \* Field 5, 6 & 7 First point on plane (third point on plane).
- \* Field 8, 9&10 Second point on plane.

Example

The following input illustrates the data to generate the levels for the string created by options 140/141

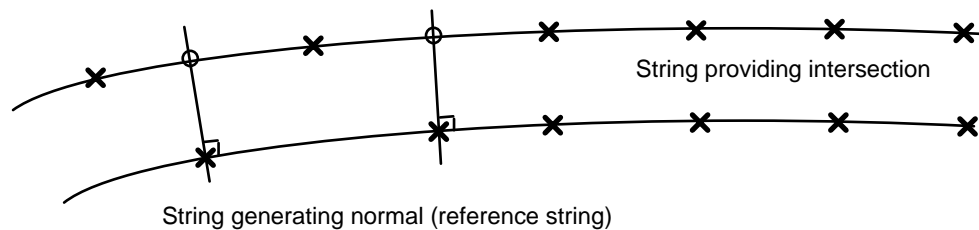
```

DESIGN, NEW THORNBROUGH
  GENERATE THE LEVEL ON STRING M007 FROM A TILTED
  PLANE (SEE OPTION 141)
152,3-M006,5=627.5,8=680.0
152,5=3494.0,4637.0,129.74,3473.0,4337.6,130.39,
152,5=3477.7,4622.2,124.90
999
  
```

## Minor option 160 Report displacements

Determines the level difference and plan distance between points on a reference string and a string specified by the user.

At each point on the reference string a normal is erected and, once an intersection is found, the level difference and plan distance are reported.



**Figure 8 - 54 Example - normal intersections**

Minor option 160 may also be used to assess the accuracy of model data prepared by DIGIT, SURVEY or GENIO. For further details, refer to “Survey accuracy validation” in Chapter 5.

The maximum length of normal is known as the section offset tolerance. It has a default value of 100 units but you may change this value using global minor option 017.

◇ *Curve fitting cannot be turned off with this minor option.*

Input

Graphics

IGDESIT.DAT, DES002, DES048

DESIGN options	Report displacements
Add comments to input log	Reference string
Define system parameters	Intersecting string
Define linear units	Subsidiary string
Add/amend string	Start chainage / X coord
Add levelsAdd/amend levels	Start point no. / Y coord
Add M-string	Sig level for vert disp
Report displacements	End chainage / X coord
End DESIGN	End point no. / Y coord
	Sig level for horiz disp

Linemode

Minor option 160

- Field 1 Reference string, from which normal is erected.  
This string must be in the first DESIGN model specified.
  - Field 2 Subsidiary string, from which displacements are measured.
  - Field 3 String to be intersected by normal.
  - Field 5 & 6 SPRD for start point of reference string where normal is erected.
  - Field 7 Significance level for vertical displacement.  
Values used may be 50, 80, 90, 95, 98 or 99.
  - Field 8 & 9 SPRD for end point of reference string where normal is erected.
  - Field 10 Significance level for horizontal displacement.
- ◇ *The significance levels in Fields 7 and 10 are only relevant for statistical analysis of the horizontal and vertical displacements. For further details, refer to 'Survey Accuracy Validation' in Chapter 5.*

Example

The following example shows the output generated by minor option 160 for two points on a reference string.

```
DESIGN, DEMONSTRATION GROUND
160, C001, , L007, 6=17, 9=18
999
```

**Output:**

LATERAL AND VERTICAL DISPLACEMENTS OF STRING L007 FROM STRING C001

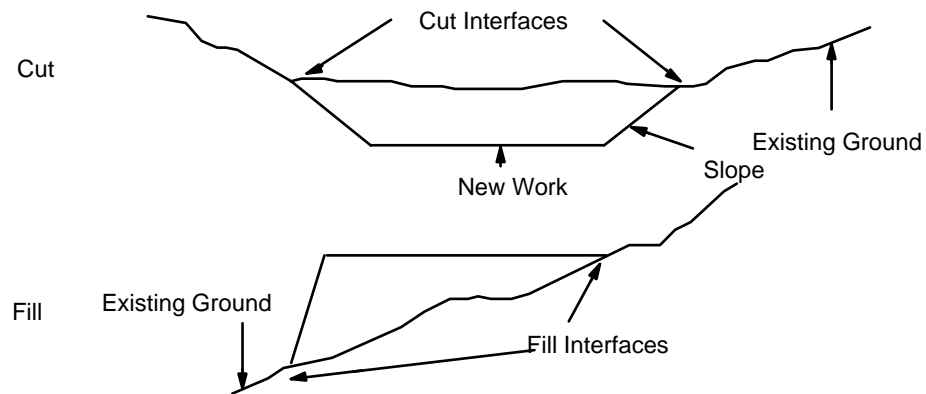
```
-----REFERENCE STRING C001 ----- --DIFF L007 FROM C001
POINT      DIST/CHAIN- ---LEVEL--- ---OFFSET-- LEVEL DIFF.
    17          160.007      57.440      -13.947      -2.348
    18          170.007      58.019      -14.095      -2.321
```

## Interface analysis

Major option INTERFACE calculates the string(s) through the points where slopes projected from one model intersect another model. The strings calculated at the INTERFACE therefore are of prime importance in the calculation of areas and volumes in a scheme.

In engineering terms the model from which the slopes are projected is likely to contain the new work (carriageway or similar) and the model into which the slopes are projected is the existing ground.

Whilst major option INTERFACE is simple to use for straightforward cases as shown in Figure 8 - 55 it is also a highly sophisticated option which can be used to calculate complex earthworks using similar techniques.



**Figure 8 - 55 Simple interface examples**

### Facilities within INTERFACE

The specification of slopes and overall shapes of earthworks varies greatly from scheme to scheme according to:-

- The nature of the scheme
- The geotechnical conditions prevailing on site
- Local engineering practice.

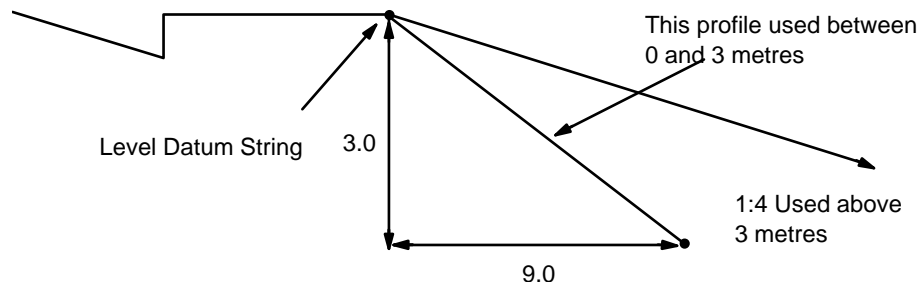
Many varying requirements for earthworks have been analysed and incorporated within INTERFACE major option.

The facilities can be separated into a number of distinct categories although in many cases these categories may be used in conjunction with one another.

### Alternative profile criteria

Major option INTERFACE allows the definition of different profiles which are calculated by the program according to height criteria set in the data. Thus, for example, a specification calling for 1 in 3 gradients for a fill height between 0 and 3 metres and for 1 in 4 gradients above this fill height can be

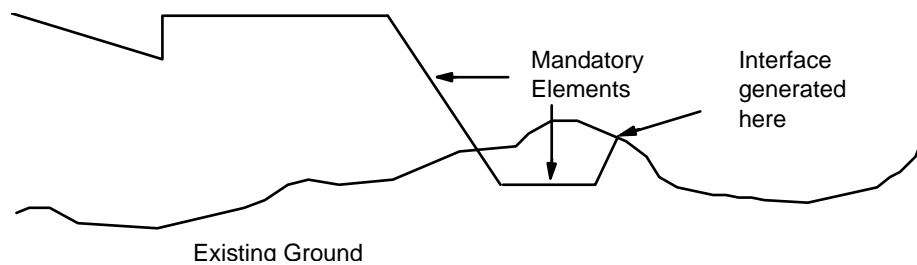
easily handled by INTERFACE as shown in Figure 8 - 56. The height used may be measured at the level datum string (as shown) or at the interface.



**Figure 8 - 56 Example – alternative profile criteria**

### Mandatory elements of profiles

Major option INTERFACE allows the mandatory inclusion of elements of profiles regardless of whether these elements intersect the ground. This facility enables, for instance, features such as ditches to be placed at all fill sections as shown in Figure 8 - 57.



**Figure 8 - 57 Example – mandatory elements of profiles**

### Automatic generation of strings through intermediate points on the profile.

Major option INTERFACE enables strings to be generated through any distinct point on the profile. This is achieved by giving a string label at the outer end of the element as it is defined. Thus it is possible to define a label for and generate strings at points defining the edges of berms or beds of ditches. This is more convenient than developing these strings by the alternative method using the DESIGN option. In Figure 8 - 58 strings will be developed through points AAAA and BBBB, so that if a section is taken across this profile it will be plotted as shown on the right. Whilst this may not be what is required, the technique of 'missing points' can be used to advantage in some complex cases.

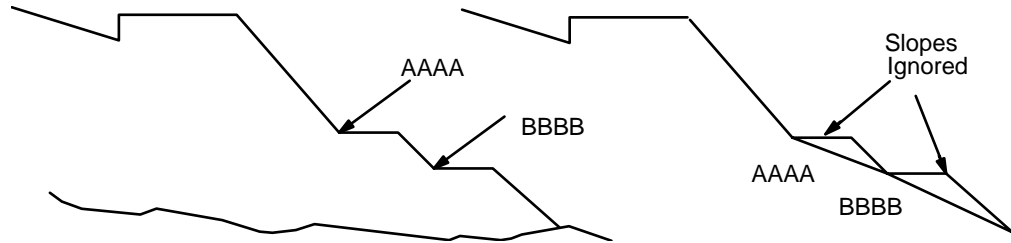


Figure 8 - 58 Example – intermediate points on the profile

Differentiation between cut and fill interface strings

There are 2 methods of handling interface strings:-

1. Generation of the interface as one string regardless of the cut/fill condition of the scheme.
2. Differentiation of the interface into separate strings for cut and fill.

The first is the more usual case and is suitable for boundary formation and when it is required to set out other strings such as fence lines from the interface string.

Where a drawing convention is used which places a cut/fill indicator on the interface string itself (rather than ‘tadpole’ hachure notation) the second method should be used.

In either case INTERFACE interpolates the plan position and level of zero cut/fill points and introduces these into the interface string (or strings) together with bearing discontinuities. The zero cut/fill point is an example of a transition area in INTERFACE ie where the profile changes between adjacent sections. In these transition areas intermediate strings (see section immediately above) are automatically trimmed to give an interpretation of how berms and ditches run in these complex positions.

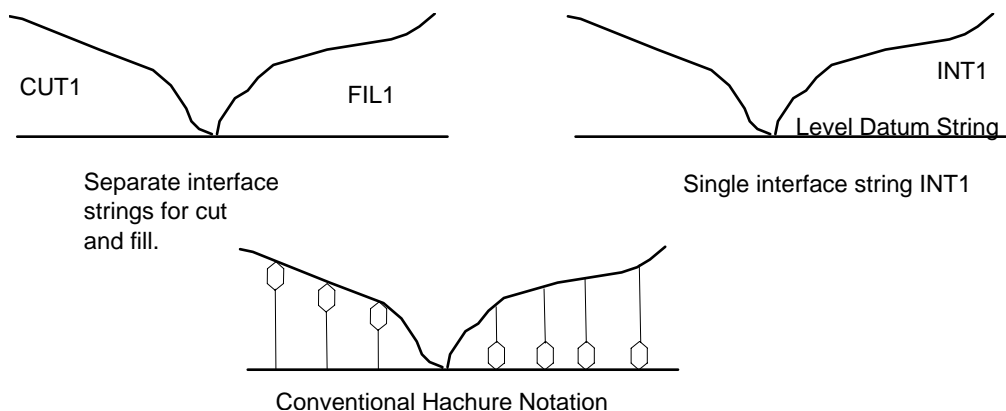


Figure 8 - 59 Example cut and fill interface strings

Interfacing into multi-strata models

Complex profiles can be generated where the gradient varies according to the stratum through which the profile passes. Not only can gradient vary



according to the stratum but berms or ditches can be introduced in a particular stratum to accommodate stability criteria and drainage requirements.

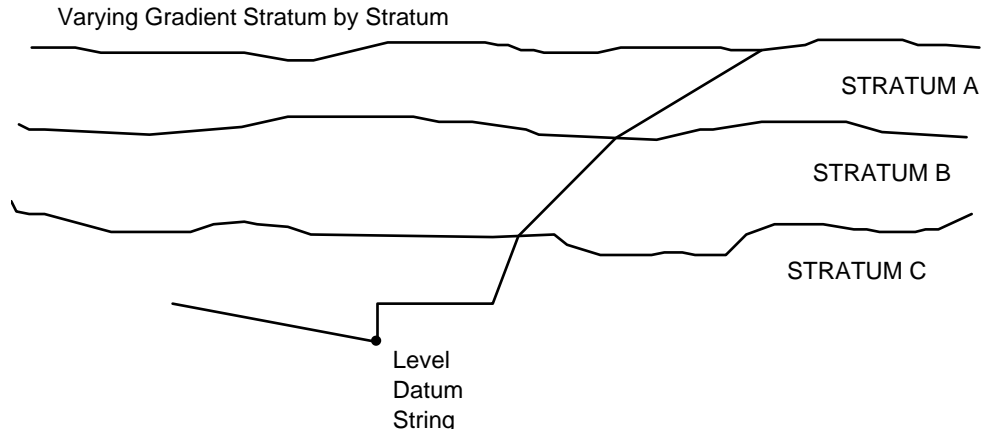


Figure 8 - 60 Example – interfacing into multi-strata models

Forward and reverse interfaces

The most common way of calculating the interface is the forward style. This is where the calculation proceeds from the new work to the ground. The reverse style is a variation on this where the calculation proceeds from the ground to the new work. The result of this can be seen in Figure 8 - 61 which shows the outcome of the same interface calculated in both forward and reverse styles. Note particularly the difference between the two styles in the placing of the variable width element and its effect on the relative levels of the berm, ground and level datum string.

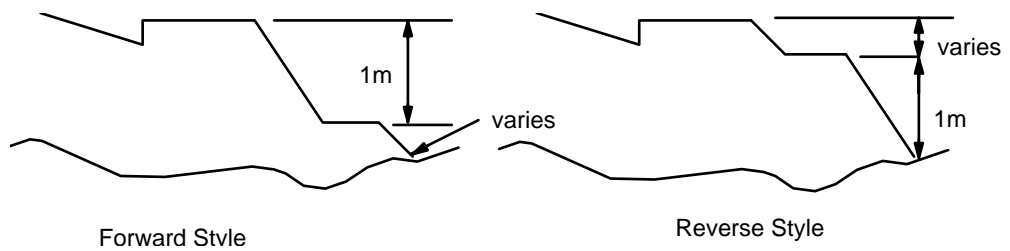


Figure 8 - 61 Examples – forward and reverse interfaces

Interface to a specific level

Slopes may be projected to a specific level regardless of whether or not there is a ground surface at that level in the model. This is particularly convenient for developing horizontal berms and benches. This facility can be mixed with others within INTERFACE so that a slope system can be specified which projects both to ground or subsurface strata and to specific levels.

### Repeat pattern interfaces

Major option INTERFACE has a facility for setting up repeat patterns in the data. Quarrying applications frequently require the repetition of a pattern of slopes and benches (berms) down the quarry face until an interface is found. These patterns may be either straightforward pairs of slopes and benches or more complex involving several slope/bench elements. Repeat patterns may be specified for cut or fill or both and they may be mixed with other Interface facilities as required.

### Principles of interface calculation

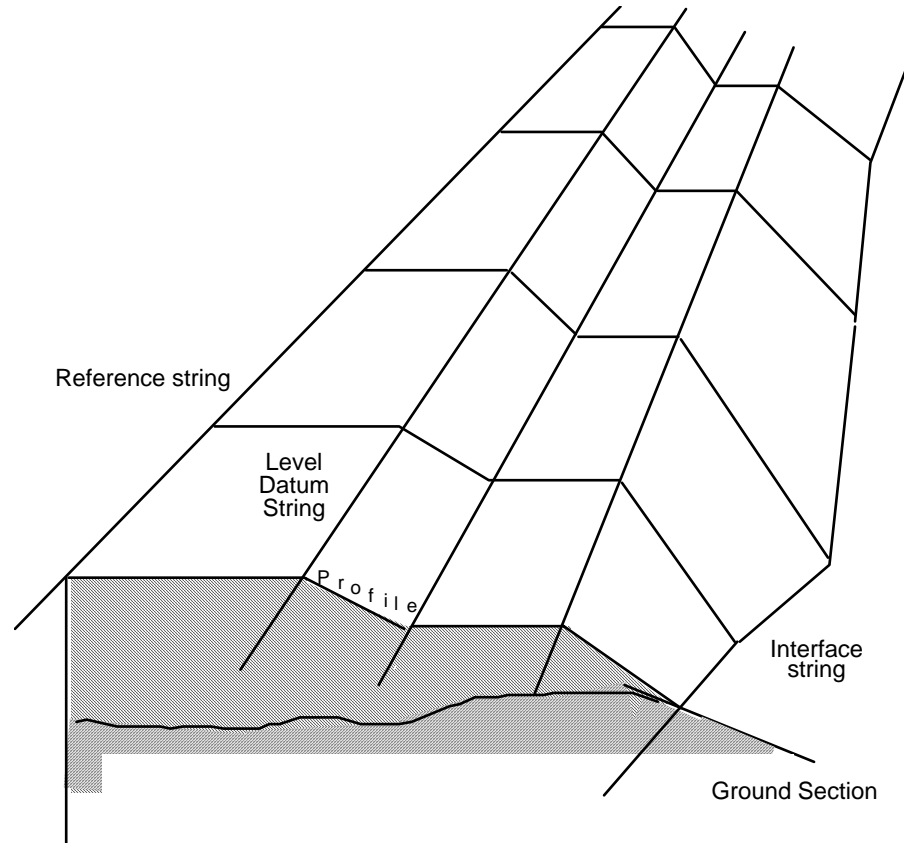
Although the facilities offered by major option INTERFACE are very sophisticated, every use of the option employs one straightforward principle. This is the computation of the position in space where a section through one model intersects a section through another model, the two sections being coincident in plan. The calculation itself is straightforward coordinate geometry but an understanding of the steps leading up to this calculation will greatly assist in the use of the major option.

The principles of INTERFACE can be readily seen from Figure 8 - 62 which shows interfacing being applied to a road design scheme.

The ground section is taken through the ground model along a normal through a point on a selected existing string in the model of the proposed surface. This string is termed the 'REFERENCE STRING'.

A 'PROFILE', representing part of a cross section through the new work, is defined along the same plan line as the ground section. The start point of the PROFILE is the point where this line cuts a selected existing string in the proposed model, this string being termed the LEVEL DATUM STRING.

The PROFILE is projected from the calculated point on the LEVEL DATUM STRING to intersect with the ground cross section at the INTERFACE.



**Figure 8 - 62 Example – showing key features for Interface calculation**

This process is repeated for each point on the reference string within the required range.

The reference string and the level datum string may be one and the same - this frequently occurs in mining and quarrying applications.

The following minor options are used to define INTERFACE data:-

- 260 Define reference string, interface string and SPRD for the range of application
- 261 Define cut elements
- 262 Define fill elements
- 263 Invoke INTERFACE analysis
- 264 Invoke rounding

In highway terms the REFERENCE STRING is likely to be a master alignment string - possibly the carriageway centre line. The Interface calculation is then performed according to the current chainage specifications. The LEVEL DATUM STRING is likely to be the back of verge or similar point from which the profile is projected to intersect with the ground at the INTERFACE either at the top of a cutting (back of verge below existing ground) or at the foot of embankment (back of verge above existing ground).

There are many instances in Civil Engineering and in Mining and Quarrying where successive uses of INTERFACE can be used to model complex earthworks by interfacing into one model and using the interface string created as the LEVEL DATUM STRING for the next calculation. The use of INTERFACE to develop ditches running at specific hydraulic gradients is shown in the examples which follow. Example 11 shows how this can be achieved by interfacing into the ground and from there to a hydraulic surface model. This principle can be readily extended into mining and quarrying particularly when regard is also taken of multi-strata interfacing. In the design of dams INTERFACE can be used to calculate the intersection points of the dam with the existing ground. A model of the dam may be developed from which strings around the periphery of the top of the dam will be used as REFERENCE STRINGS and LEVEL DATUM STRINGS. The profiles may be projected from here to intersect with the existing ground and other sub-surface models if required. The volume of material in the construction can then be calculated.

INTERFACE has widespread application in site layout work for calculating the geometry of plant foundations and in all circumstances in which a relationship between two models can be defined by means of a slope system between them.

### Profile construction

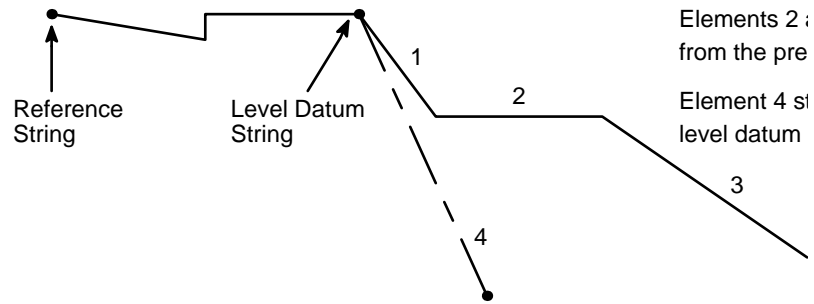
A profile is made up of one or more ELEMENTS, each of which is defined by the user. Associated with each ELEMENT are a start point, a horizontal width, a gradient and an end point (although in many situations width and/or end point may be omitted). ELEMENTS are only related to one another by their start and end points. Identification of these start and end points is by means of labels, which can be provided either by the program or by the user.

Each element is defined by one INTERFACE minor option (261 or 262) which specifies the start point, the width, the gradient and the end point, and a profile is defined by a series of one or more of these options. There is significance in the order in which the elements are defined, in that the start point of each element must be the end point of a previous element in the series. Other than this connection, the elements are independent of one another.

The first element must have a point on an existing string as its start point. This is achieved by specifying the label of the string in the data: this string is the level datum string. The element can then be fully defined in space, with known coordinates at the start and end points.

The next element is defined in a similar fashion, except that the start point can be either the level datum string or the end point of the first element. This second element can then be fully defined in space. Subsequent elements can start at either the level datum string or the end of any of the previous elements.

A profile has been fully defined when all the elements have been defined.



**Figure 8 - 63 Example – profile construction**

**Calculation of the interface**

Each of the elements in a profile is taken in order. Given the coordinates of the start point by reference to either the level datum string or to a previous element, the coordinates of the end point are calculated and an intersection with the ground profile is sought. If an intersection is found then this becomes an interface point; if not, subsequent elements are processed in the same way until an intersection is found. Any remaining elements are not processed. If no intersection is found then no interface point is generated.

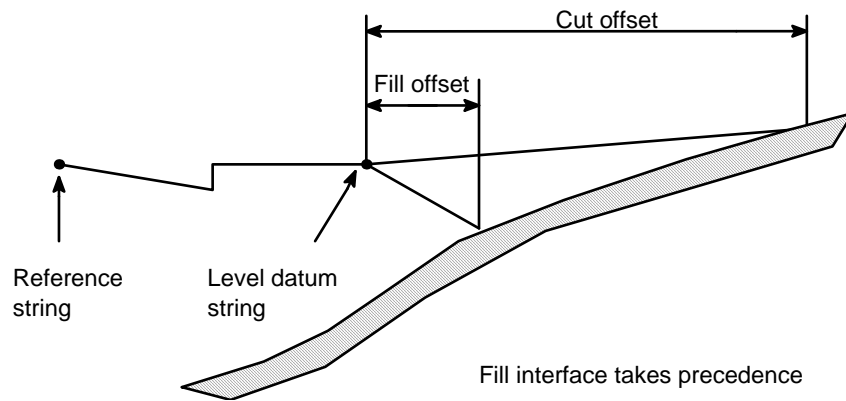
**Cut/fill precedence**

In some situations, both a cut and fill interface are equally valid. There are two ways of specifying whether the cut or the fill interface takes precedence:

- Cut and fill 261 and 262 minor option order
- Shorter offset method

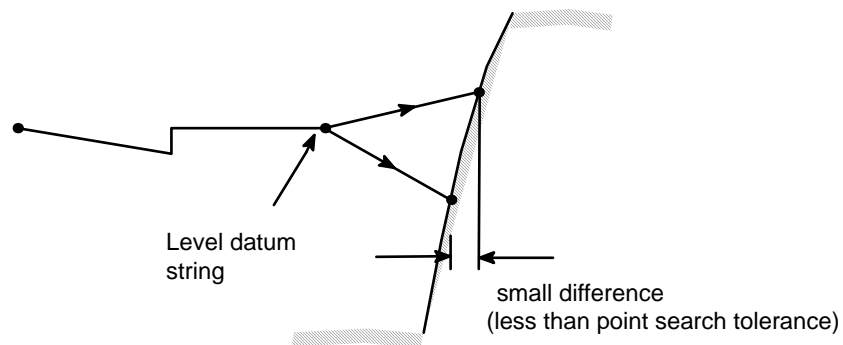
With the first method, the data set of 261 and 262 minor options may be regarded as a decision table. Each line of the table is processed in order to find the interface regardless of whether it is a 261 or 262 option. The first valid intersection is taken as the interface point and no further records are processed. If at the end of the data a valid intersection has not been found a warning message is printed and the calculation progresses to the next cross section.

With the second method, the interface with the shorter offset from the level datum string takes precedence, as shown in Figure 8 - 64.



**Figure 8 - 64 Cut and fill interface offsets (large difference)**

In some applications, such as quarrying, where the ground profile is almost vertical, the distance between the cut and fill interfaces can be very small. In this case, if, at a section, the difference between the cut and fill offset is less than the point search tolerance (see global minor option 017), the same interface as that taken at the previous section is used. For the first section (where there are no previous sections), if the difference between the cut and fill offset is small, the decision table method is used.



**Figure 8 - 65 Cut and fill interface offsets (small difference)**

In complex cases it may be helpful to consider the amount of freedom INTERFACE is given to arrive at its result. This 'freedom' applies to the specification of width of elements. Because INTERFACE has to project a slope from one model to the other it is as well to give the program the freedom to do this by not restricting the width of one of the elements. In the forward style this 'stretchable' element will be that between the last point on the profile and the interface with the ground. In reverse style the 'stretchable' element will be between the level datum string and the first point on the profile. In either case the 'stretchable' element will change in width (and hence in depth or height) to accommodate varying depth of cut or height of fill.

By default (achieved by leaving field 5 blank on the 261 or 262 minor option) the 'stretchable' element will be projected over a maximum width of 1000

units. However in conditions of very shallow slopes this may be extended by specifying a width greater than 1000 metres which in effect increases the range of 'stretchability' of the element.

Widths may be specified for every element but this restricts the freedom of the solution as it can only calculate the interface within this overall width of the profile specified. At sections where this is inadequate the 'INTERFACE NOT FOUND' warning message will be printed. The technique of restricting depth of cut and/or height of fill in this way may however be helpful when earthworks must be restricted within a range (imposed in the data by width restrictions) as the location of any violation will be highlighted by the warning messages.

### **Use of sections by INTERFACE**

INTERFACE uses ground or strata cross sections as already described. In general these sections may be those already stored by the SECTION major option or sections may be generated automatically by INTERFACE.

Automatic sections are generated through each point on the reference string but are not stored following INTERFACE. Automatically generated sections are labelled according to the convention -

Axxx            where xxx is the point sequence number on the reference string through which the section is taken to find the interface. The range is A001 to AZZZ inclusive.

When automatic sections are used the model into which the profiles are projected contains the strings defining the existing surface.

The section sets for the stored sections method are generated using the SECTION major option. In this case the model into which the profiles are projected contain these ground cross sections. Care should be taken not to duplicate effort by generating automatic sections when a suitable set of sections is already stored.

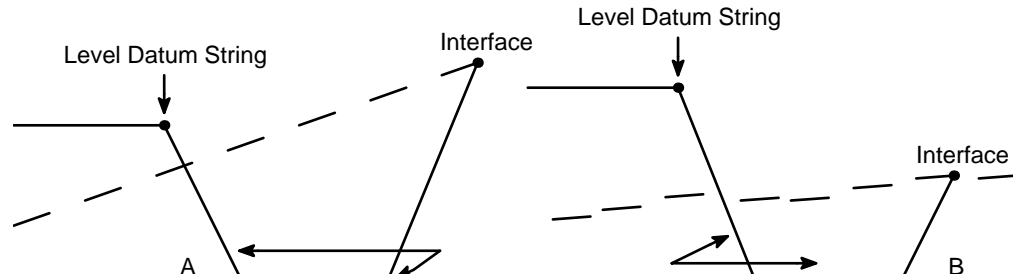
It is a matter of engineering judgement to decide at what intervals sections should be taken to define an interface string of sufficient accuracy. A longer interval will be permissible in straightforward situations with few transitions from cut to fill. In this consideration the behaviour of the interface and the intermediate points at transition areas should be borne in mind.

### **Interface design considerations**

In the preparation of data for INTERFACE the user should be aware of some more subtle considerations particularly if dealing with complex profiles and/or multi strata ground. These considerations concern what is meant by cut or fill, the generation of hachure notation, and the use of mandatory elements.

### **Cut and Fill**

The convention that elements are defined for use in cut by minor option 261 and for use in fill by minor option 262 is useful although to some extent it is a notional distinction. The reason being the potential dilemma between what is a cut profile and what is a fill profile.



**Figure 8 - 66 Example – showing complex cut and fill profiles**

Figure 8 - 66A shows a section which at first sight seems to be in cut. The reason for this is that the interface point is above the level datum string. However the ground at the level datum string is below the profile so by another criterion the section is in fill. In Figure 8 - 66B the interface string is below the level datum string and so would seem to be in fill; the ground is also below the level datum string and would seem to be in fill; yet by a third valid criterion (the gradient of the last element of the profile) it seems to be in cut. Furthermore the profile is in essence no different from that in A.

Because of this the user must decide which elements are for cut (on 261s) and which are for fill (on 262s). In straightforward cases this will be obvious but for these and for ambiguous cases as described above the following rules apply:-

1. Interface points found on profiles defined by 261 minor options will be stored on the interface string defined in field 2 of the preceding 260 minor option.
2. Interface points found on profiles defined by 262 minor options will be stored on the interface string defined in field 3 of the preceding 260 minor option.
3. Where a profile changes from one defined on 261 elements to one defined by 262 elements (or vice-versa) between adjacent sections the interface string will be interpolated back to the level datum string at an intermediate point between the sections. This process is described in the section on transitions between profiles. The zero offset point generated is at the position of zero cut/fill. If such a point is not required at a transition between profiles then the choice of 261/262 will need to be reconsidered.

Because of the decision table approach the cut/fill condition of the scheme itself is disregarded in the calculation of the interface - only geometrical considerations apply to find the first valid intersection. However the secondary considerations of string storage and interpolation at transitions make it necessary to give careful consideration to the choice of 261 and 262 minor options for elements of profiles.

### Hachure notation

When drawn with major option DRAW using detail interpretation interface strings have hachure notation associated with them. General drafting convention is that all sloping elements on profiles have hachure whereas



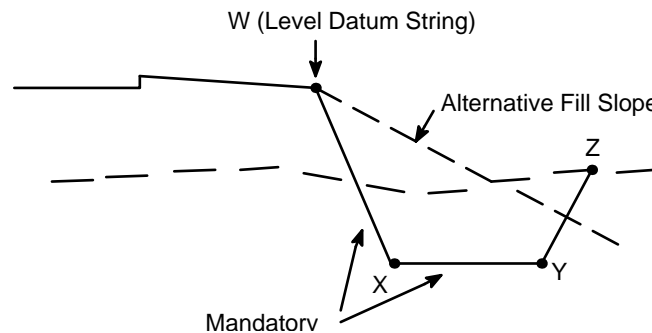
flat elements, (berms, tops of benches, ditch beds etc), do not. As a nominally cut slope can have elements which should be shown with fill hachure notation and vice versa, the method of hachure calculation needs explanation. The rules are:-

1. Hachure notation for elements is calculated automatically from geometrical considerations of level difference between points on adjacent string provided the string at the outer end of the slope is 5 dimensional (which is the default case).
2. Hachure can be omitted if the string at the outer edge of an element is generated as a 3 dimensional string (by using field 4 of 261 or 262 records).

Thus hachure notation is always included unless otherwise specified (as would be usual for flat element) and is independent of element specification via 261 or 262.

### Mandatory elements on profiles - general case

Certain situations require profile elements which are mandatory regardless of whether the element intersects the ground. An example is shown in Figure 8 - 67 where the ditch is always required if the point z is in cut. This means that intersections with the ground in elements WX and XY must be ignored in the interface calculation and this can be achieved using ignore the intersection indicator IGN in the data as explained below.



**Figure 8 - 67 Example – mandatory elements on profiles**

However this case raises the question of what happens when the cut criterion is as above and the fill profile extends from point W. Both profiles are then equally valid. The profile can be chosen automatically by specifying that the profile with the shorter offset from the level datum string takes precedence, or the user may determine the precedence by the order in which he submits the minor options (261, 262), the first taking priority over the second.

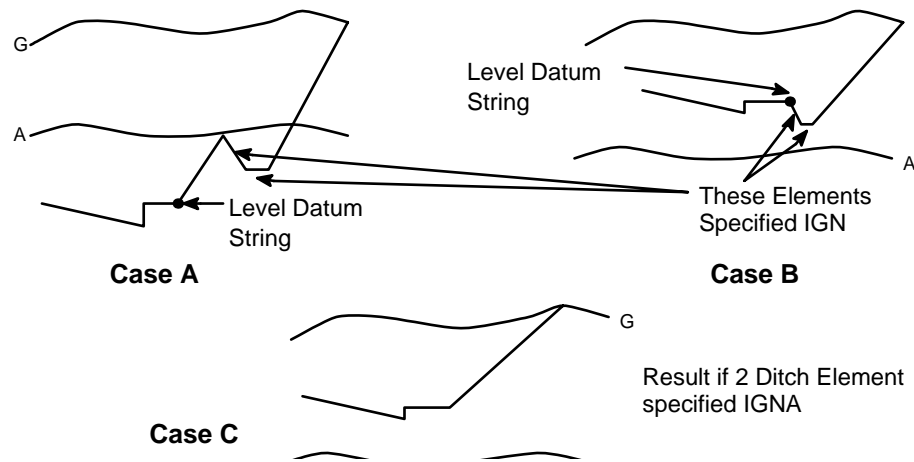
### Mandatory elements in multi-strata - special case

When defining profile elements in several strata, the program recognises the change from one stratum to the next, usually by reference to section set letters. When an IGN record is coded, this information is not available. If the records on either side of a block of IGN records are to different strata, then

these IGN records are assumed to be the first profile elements in the following stratum, ie the change point between strata is taken as the first IGN record.

There are circumstances in which the application of this rule would not give the desired result.

Consider Figure 8 - 68:



**Figure 8 - 68 Example – mandatory elements in multi-strata exceptions**

Case A shows an example of multi-strata interfacing where two elements forming a ditch are constrained to be present at the interface with stratum A by means of the IGN indicator on the 261 records defining these elements. This is satisfactory but may only be so when the scheme is below section set A.

Case B shows what happens if the scheme lies between the sections sets G and A so that no interface can be found with A. By using IGN the ditch elements are placed immediately on the level datum string and then the gradient for section set G applies from the outer edge of the ditch. This may not be what is generally required but it follows the general rule that IGN applies to the section set which follows next in the 261/262 minor options. (Although IGN is not transferred between 261 and 262 or vice versa).

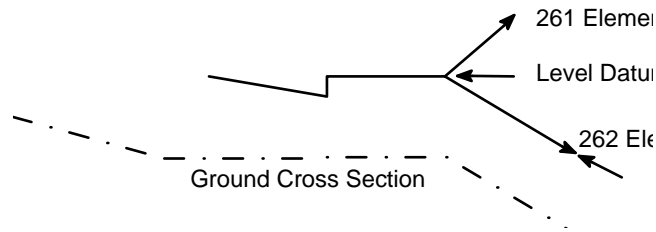
Case C shows the result which is more likely to be that needed. The elements which make up the ditch are only required if an interface has been found into section set A. If this interface is not found, then these elements are to be omitted, and processing should continue with the first element after the ditch elements.

To attach this special significance to these ditch elements, a fourth character must be added to the IGN indicator on each of these records. The program then produces the desired result. This fourth character may be any character.

**Interface not found**

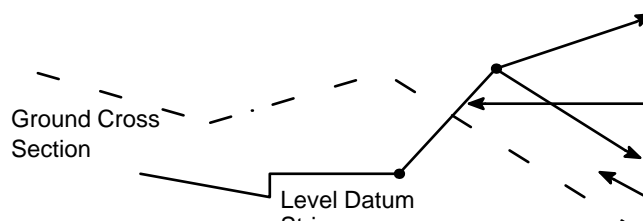
There can be several situations where none of the elements in the decision table of the 261 and 262 minor options will intersect with the ground. Among these are:-

An element being parallel to the ground - Figure 8 - 69.



**Figure 8 - 69 Example – Interface not found**

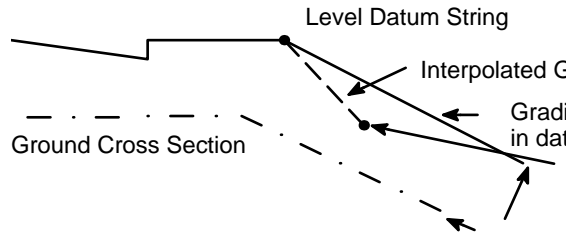
An IGN element forcing all the elements on which intersections are allowed outside of a ground section - Figure 8 - 70. This case can cause confusion in multi-strata situations.



**Figure 8 - 70 Example – Interface not found**

A warning message will be printed for every section where interface can not be found. The scheme should be examined carefully in such areas because INTERFACE will proceed to calculate an interface point by the interpolation process used to calculate zero cut/fill points and to trim intermediate strings. This point cannot be the true interface point and may be outside of the scheme in plan and/or level. This is best detected by examination of graphic cross sections and any unacceptable results may be corrected by use of the EDIT major option. The position of the interpolated interface point may not be far from a realistic solution. However as it depends on the position of the interface at adjacent cross sections it is unlikely to be suitable in areas of undulating ground.

Note that the gradient of elements as defined in the data is not used in the interpolation process with gradients being calculated from the interpolated points. Accordingly gradients will not be as entered and may be unsuitable as indicated in Figure 8 - 71.



**Figure 8 - 71 Example – Interface not found**

The same interpolation process applies to any intermediate points between the level datum string and the interface so the strings through such points are subject to the comments made above.

### Styles of Interface

There are 4 styles of interface:-

- Forward
- Reverse
- Multi-strata
- Forward with surface height adjustment

Each of these styles can be used with stored section or fixed level interfaces. Only forward and reverse styles can be used with auto-section.

### Forward interface style

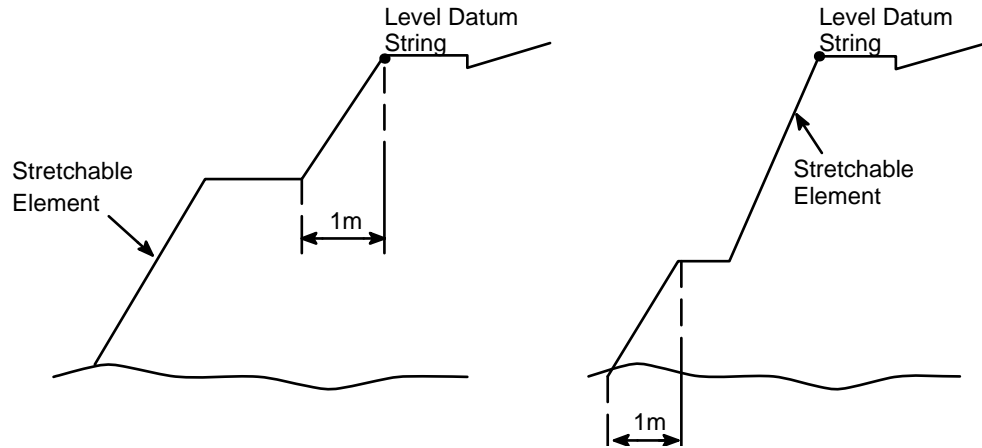
This is the usual and most straightforward style. The calculation progresses from the level datum string to the interface with the ground. The major consequence of using forward, rather than reverse, style concerns the treatment of intermediate points, such as those on berms and ditches.

Forward style interfaces are invoked by the use of an indicator on the 260 minor option. (See section on data preparation).

### Reverse interface style

The reverse style allows the calculation of the interface working in the direction from the interface string to the level datum string.

The reverse style is used where it is required that intermediate strings on the profile run parallel to the interface string rather than parallel to the level datum string. Note in Figure 8 - 72 the contrasting positions of the 'stretchable' element in the profile.



**Figure 8 - 72 Examples – forward and reverse styles**

Reverse style interfaces are invoked by the use of an indicator on the 260 minor option.

### Multi-strata interface style

This style is used when interfacing into models where several strata are defined. This style enables different elements to be used in the different strata of the model.

The Interface style for multi-strata work is not defined directly in the data. INTERFACE itself decides if multi-strata style is appropriate by detecting multiple section sets, changes in surface height adjustment or changes in fixed levels. Reverse style does not apply to multi-strata interfacing.

The key to successful multi-strata interfacing is to realise that each stratum is considered as a separate interface calculation, and that the same rules apply within each stratum as apply in a single stratum data set. Each has a level datum string as explained below, a series of profile elements and a final interface string.

The level datum string for each stratum is that specified as the start point of the first element in that stratum. This must be an existing string only in the first stratum; thereafter it is generated by the program.

Profile elements can be defined for each stratum in the same combinations and sequences as for a single stratum.

The string label for all intermediate interfaces is taken as that specified as the level datum string in the following stratum. It is significant that this label is used for the intermediate interface regardless of which profile element intersects with this surface. This ensures a continuous string at the junction between strata.

The string label for the final stratum is specified in the appropriate field on the 260 record.

If an intermediate interface is not found, the stratum is ignored, except that its level datum string, being the intermediate interface for the preceding stratum, is carried forward to replace the level datum string for the next

stratum. A warning is issued, and the analysis continues. However, if the final interface is not found, no string points are stored at that section.

**Forward with surface adjustment**

This case is a variation on the usual forward case where the gradient is constrained to change at a specified depth above or below the surface of the ground.

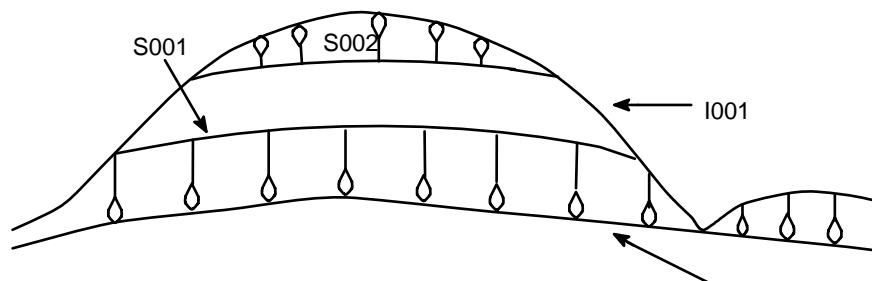
This style is not defined directly in the data. The 261 minor option for the cut element defines the depth above or below ground for which the element with this gradient is appropriate and this acts as the trigger for MOSS to detect this style of interface. (See section on data preparation). Surface adjustments may also be entered on 262 minor options. Example 9 shows this style in use.

**Generation of strings**

Interface will calculate strings through any intermediate points on a profile which have labels defined on the appropriate 261/262 minor options. These strings are generated subsequent to the generation of the interface string and the generation process involves the trimming of the strings at transition areas.

Care must be taken that strings with the correct number of dimensions are generated so that drawings with detail interpretation may be successfully produced. Also labels for strings through intermediate points on profiles defined by elements on 261 minor options must not be the same as the labels for points on profiles defined by elements on 262 minor options.

Interface strings themselves always have 5 dimensions which enables them to be drawn with hachure notation. When intermediate points are introduced between the level datum string and the interface string the strings through these points will also, by default, be generated with 5 dimensions. However this could lead to too much hachure notation being included in some circumstances so an option is available to reduce the number of dimensions to 3 to avoid this. This is demonstrated in Figure 8 - 73.



**Figure 8 - 73 Example – hachure notation**

String Label	Sub Reference	Dimension	Interpolation
I001	INTC	5	with hachures (cut)
S001	INTC	5	with hachures (cut)

S002	-	3	without hachures
I002	INTF	5	with hachures (fill)

The above table shows the correct way to generate the strings. However if string S002 had been generated with 5 dimensions, hachure notation would be drawn across the bed of the ditch which is obviously not required.

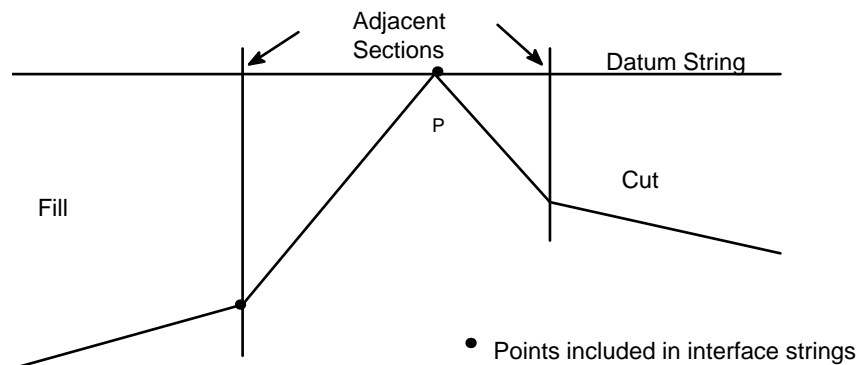
In this example S001 and S002 would be generated by naming them on the 261 minor options. The same names must not be used on 262 minor options.

### Transitions between profiles

Transitions between profiles will occur in either of two situations within the range of application of an INTERFACE major option:-

1. A cut to fill transition has occurred. This is detected by the profile at one section being defined on 261 elements and at its neighbouring section being defined on 262 elements (or vice-versa)
2. A different element or combination of elements has been used because the depth of cut (or height of fill) has reached one of the critical values specified by the data.

It would be coincidental that a profile transition occurred exactly on a section used for calculation of the interface. The INTERFACE option calculates the transition point and introduces this point together with the appropriate discontinuities into the interface string(s) as shown in Figure 8 - 74 .



**Figure 8 - 74 Transition from fill to cut**

Intermediate points across profiles, such as those defining berms and ditches, need special treatment at transitions as shown in the plan views below. The extra points added to the interface string may give rise to results which, whilst correct, may seem inconsistent in level with the rest of the interface string.

Where berm or ditch strings are included the intermediate strings must be terminated. At the termination points a point is also included in the interface string at the level of the berm string - this maintains the integrity of the model at that point. This is shown in Figure 8 - 75.

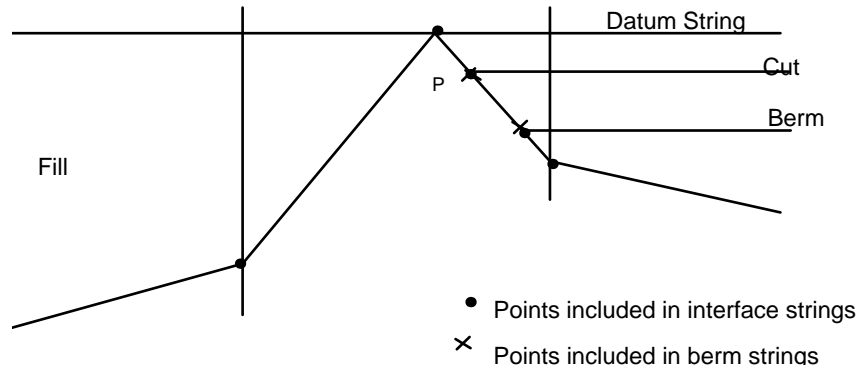


Figure 8 - 75 Transition from fill to cut with berms

For the reverse case berm strings will be parallel to interface strings. There will be points where berm strings meet the level datum string and additional points are generated for the berm strings at these points.

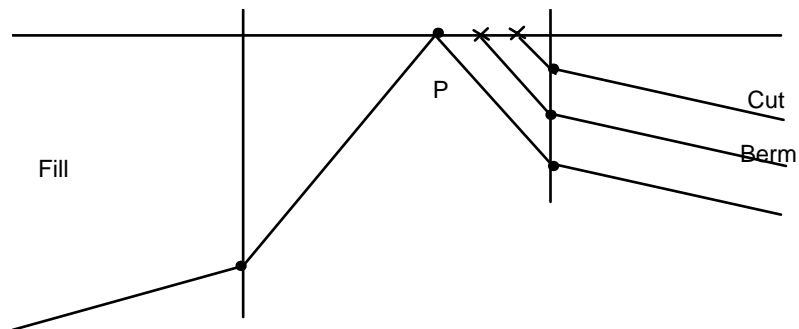


Figure 8 - 76 Transition from fill to cut with berms - reverse case

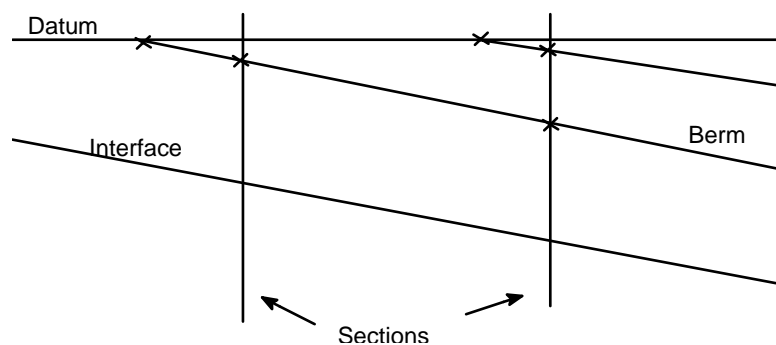
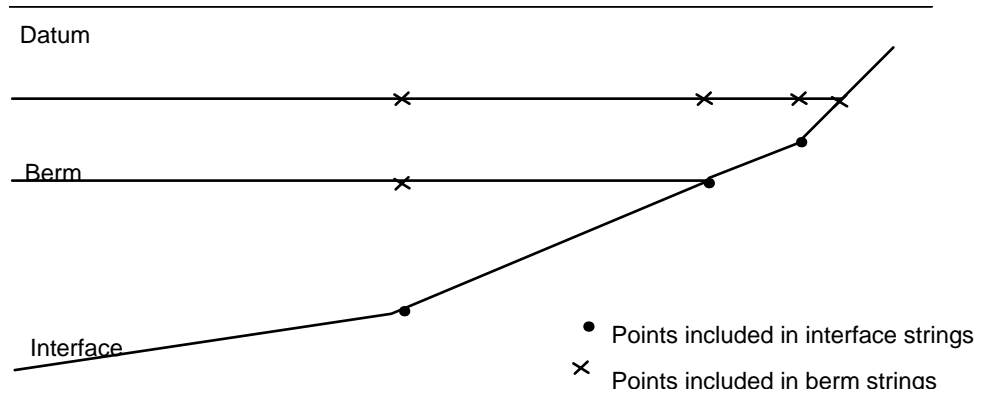


Figure 8 - 77 Foreshortening of profile

The profile itself can become foreshortened because of the position of the interface point and in this case the intermediate strings are extended to meet the level datum string.

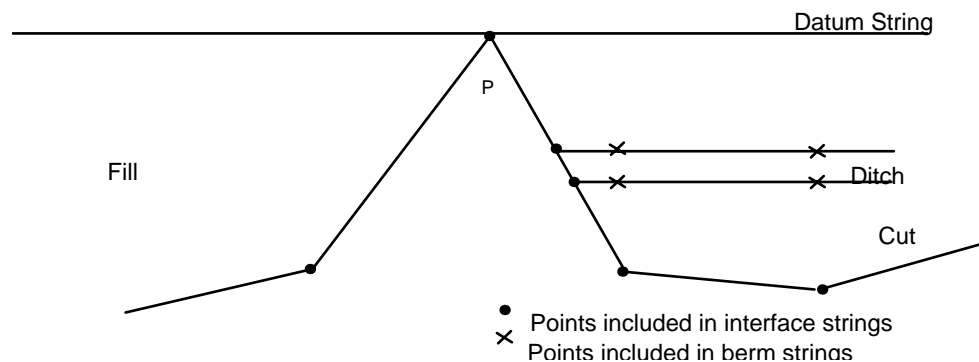




**Figure 8 - 78 Extension of profile**

The profile itself can become extended because of the position of the interface point and in this case the intermediate strings are extended to meet the interface string. Again the common point between the interface and the intermediate string is included in both strings with level taken as that of the intermediate string.

The most complex transition between profiles occurs when two consecutive profiles are unrelated. An example of this is when an embankment slope is replaced by a complex cutting slope



**Figure 8 - 79 Complex transition**

The correct position of the point P does not occur at the datum string, but no single solution criterion will always be acceptable. A warning is therefore output and the point P is still generated and included in both cutting and embankment interface strings.

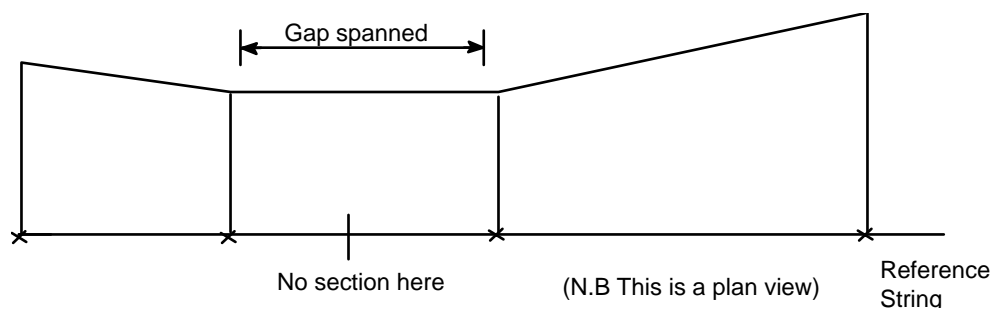
As can be seen there are several complex situations involved here. INTERFACE can only generate intermediate points according to its mathematical rules and where this happens corrective action may be needed. The interface and other generated strings should be examined carefully in the area of transitions to see that the model represents the intended engineering solution. If not the strings may be easily modified using EDIT options.

In multi-strata interfacing there are cases where intermediate strings are only generated at the section points without interpolation taking place. This is because the interpolated result would be less helpful than the truncated strings because of inevitable inconsistencies in level.

**Inadequate ground section**

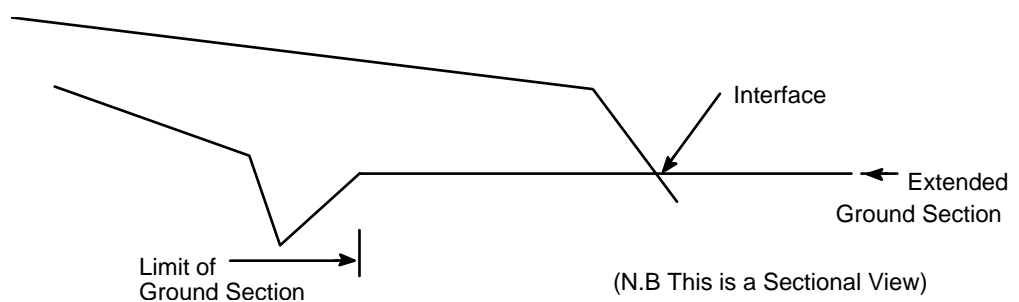
There are two situations where the interface string is computed even though there would seem to be inadequate ground information to allow this.

The first is where using stored sections a section is missing from one or more points on the reference string. In this case the interface string is generated to span the gap at the missing section as shown in Figure 8 - 80 and a warning is printed.



**Figure 8 - 80 Inadequate ground section – spanned gap**

The second is where the ground section is of insufficient width at a particular point to allow the profile to intersect with the ground. In this situation the ground section is projected horizontally 1000 metres from the extreme point on the ground section. This would normally allow the intersection to be found but if not a warning is printed. This is shown in Figure 8 - 81. Where ground section extension has been necessary an indication is given on the output.



**Figure 8 - 81 Inadequate ground section requiring extension**

### Standard and rounded interfaces

Interfaces can be generated which conform to national design criteria. For example, German design standards stipulate that embankments which have a height equal to or greater than 2m should have a standard slope of 1:1.5. Refer to 'Design standards for rounded/standard slopes' for further details.

Rounding can be applied to standard design interfaces. A single curve approximating to a parabola is inserted between the interface profile and the ground surface when rounding is invoked. The resulting rounded surface can be viewed in three dimensions using VIEW or EPIC.

The standard values stored in the parameter file are:

- Tangent length at rounding
- Standard slope
- General slope

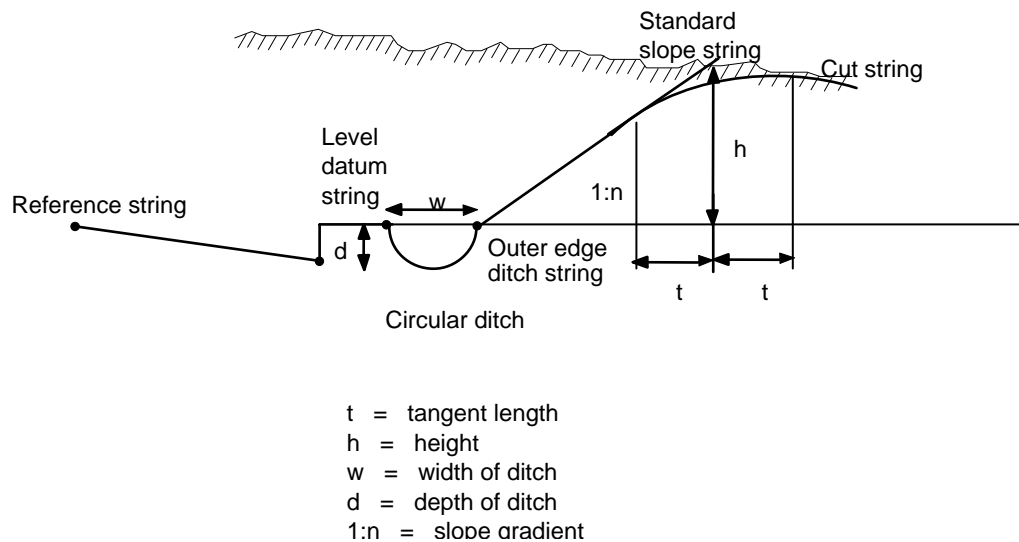


Figure 8 - 82 Rounded interfaces and ditches

### Circular ditch

Circular ditches can be created using a section of a circular arc defined by a width and a depth.

The circular ditch record (identified by 'CIRC' in the first field) produces subsidiary 261 or 262 records for each of the slopes which define the cross section of the ditch.

The widths and slopes of the generated records are obtained by dividing the arc of the ditch into equal length sub arcs as shown in Figure 8 - 83.

The labels of the intermediate strings generated by the circular ditch option are derived from the label of the string at the outer edge of the ditch. The form of this label should be AANN+1 where AA are any two characters and NN is the number of intermediate strings.

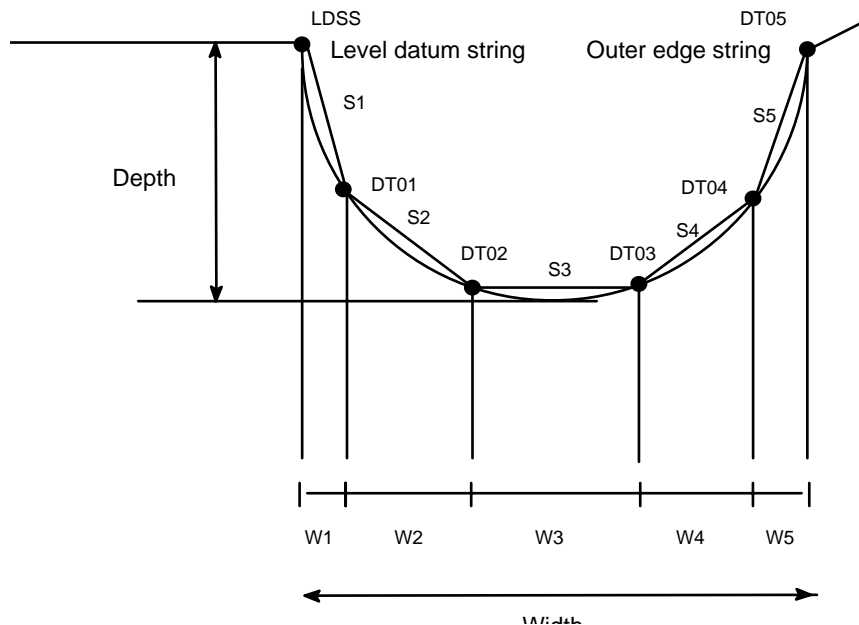


Figure 8 - 83 Circular ditch

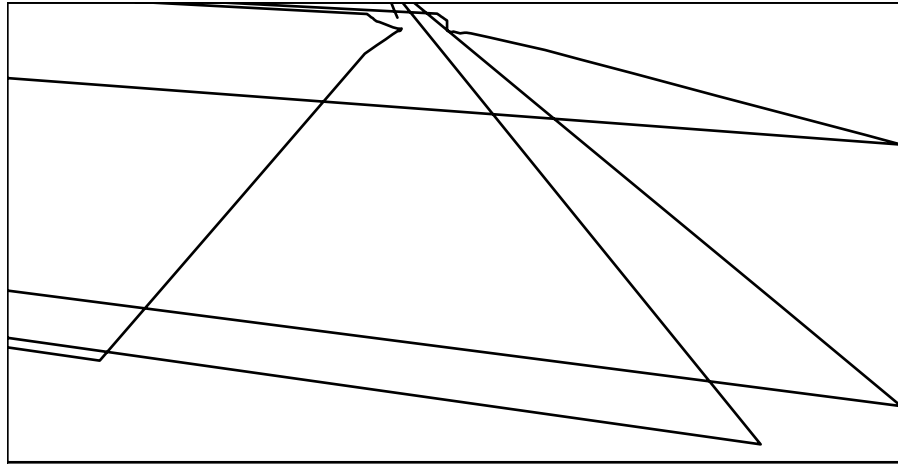
In general, a record of the form:

261, CIRC, LDSS, DT05, 4=3, 5=WIDTH, 6=DEPTH, 8=4

is equivalent to the following:

- 261, IGN, LDSS, DT01, 4=3, 5=W1, 7=S1
- 261, IGN, , DT02, 4=3, 5=W2, 7=S2
- 261, IGN, , DT03, 4=3, 5=W3, 7=S3
- 261, IGN, , DT04, 4=3, 5=W4, 7=S4
- 261, IGN, , DT05, 4=3, 5=W5, 7=S5

Figure 8 - 84 Composite drawing of rounded interfaces and ditches



**Figure 8 - 85** Perspective drawing of rounded interfaces and ditches

Detailed description of INTERFACE minor options

The following minor options are available:-

- 260 Define Reference string, Interface string(s) and the direction and range of application
- 261 Define cut elements.
- 262 Define fill elements.
- 263 Invoke the Interface analysis.
- 264 Invoke rounding

The INTERFACE major option precedes a number of blocks of minor options 260, 261, 262, 264 and 263. Each of these blocks of minor options constitutes a set of interfacing data and defines slopes, their range of application via SPRD and the labels of interface and other strings to be created.

A typical arrangement of minor options may be:-

```

INTERFAC      ....Define models
260           ....Define interface labels and SPRD
261           ....)
261           ....) Profile definition (cut)
261           ....)
-----
261           ....Profile definition (alternative cut)
-----
262           ....)
262           ....) Profile definition (fill)
-----
263           ....) Generate interface and associated strings
-----
260           ....) Define interface labels and SPRD for second
                ....) interface with same models
261           ....)
261           ....) Profile definition (cut)
261           ....)
-----
261           ....) Profile definition (alternative cut)
-----
262           ....)
262           ....) Profile definition (fill)
-----
263           ....) Generate interface and associated strings
999

```

Thus several interfaces may be calculated within a single INTERFACE major option. There are some rules to follow in preparing data for the INTERFACE option.

1. The maximum combination total of 261 and 262 options that may be used in one set (ie between 260 and 263) is 100.
2. Either 261 records or 262 records may be omitted from the data. However this does run the risk of obtaining more 'Interface not found' messages than may be required and also not writing points to the appropriate interface string. In this case no zero cut/fill points can be generated.

3. If a fill profile must take preference over a cut then the 262 records must precede the 261 records.
4. It is recommended that standard profile data be built into macro commands, or standard data sets.
5. The INTERFACE major option is additive in that if either of the strings named on the 260 minor option already exists with the design model then INTERFACE will add further points to it. Thus an unwanted interface string will need to be deleted prior to its recalculation by a further INTERFACE run.
6. For linear schemes such as roads and railways it is strongly recommended that the interface string on the left hand side be given a different label from that on the right. Otherwise the calculation will progress in the direction of increasing chainage on, say, the left and assign points to the interface string. On completion of this side the calculation passes to the right hand side and writes to the same interface string. However there will be a string between the last point on the left and the first point on the right. Which, besides being not what is required, can cause considerable confusion when any further cross sections are taken.

This can be avoided by the use of different labels for the interface strings on either side.

## Major option INTERFACE

Major option INTERFACE is one of the few MOSS major options where the name has to be truncated to the maximum allowable - 8 letters. Hence INTERFAC.

The features available in major option INTERFACE may be selected and operated from either interactive graphics or linemode. The approach used in graphics does not always parallel that used in linemode, consequently the documentation for the two modes is separate and in the following order -

- Graphics
- Linemode

### Major option INTERFACE - Graphics

### Access to major option INTERFACE

Design Options
INTERFACE



## Model selection

IGINTET.DAT, INT001, INT002

Models for INTERFACE	INTERFACE option details
Model to be interfaced	Add comments to input log
Reference and output model	Define system parameters
	Define linear units
	Define string masking
	Interface environment
	Define strings
	End INTERFACE

**Add comments to input log** provides access to global minor option 000.

**System parameters** provides access to global minor option 017.

**Define strings** provides access to the INTERFACE minor options.

## Height criteria

This option is equivalent to minor option 259, 'Height criteria' to which you should refer for a full description.

IGINTET.DAT, INT002, INT016

**Input**

INTERFACE option details	Interface environment
Add comments to input log	Height criteria (T)
Define system parameters	
Define linear units	
Define string masking	
Interface environment	
Define strings	
End INTERFACE	

**Height criteria** may be toggled between INTI and DATM.

INTI selects the height criteria used to be the height difference between the level datum string and the interface (default).

DATM selects the height criteria used to be the height difference between the level datum string and a point vertically above or below.

## Define strings

### Input

IGINTET.DAT, INT005, INT006

Define strings	Interface details
Reference string label	Input macro data
Label for cut	Simple single slope
Label for fill	Simple slope/berm
Style of interface (T)	Rounded/standard slope
Smaller cut/fill width (T)	Add discontinuities (T)
Start chainage / X coord	
Start point no. / Y coord	
Profile points limit	
End chainage / X coord	
End point no. / Y coord	

**Reference string label** defines the string on which the interface is based.

- ◇ *In IGmode stored sections can only be accessed from within a macro. If stored sections are used they must have been determined relative to this reference string.*

**Label for cut** is the label used for CUT strings.

**Label for fill** is the label used for FILL strings.

- ◇ *TEither the 'Label for cut' or 'Label for fill' fields may be left blank in which case the label from the non-blank field will be used for the vacant field. This has the same effect as entering the same label in both of these fields - the same string is used for cut and fill interfaces. It is incorrect to leave fields 2 and 3 blank.*

**Style of interface** is a toggle indicating the direction (forward or reverse) of the cut and fill strings generated to the right or left of the reference strings.

**Smaller cut/fill width** is a toggle which determines whether cut/fill interface precedence is determined by shorter offsets or minor option order.

**SPRD for start** defines the point where interfacing is to begin on the reference string.

**Profile points limit** is the maximum number of profile points generated on any one section. This is set by default at 50 which will suffice for most jobs and therefore in most instances it will not be necessary to enter a value for this field. If required it can be set within the range 2-200 although setting this limit unnecessarily high may have a detrimental effect on processing time.

**SPRD for end** defines the point where interfacing is to end on the reference string.

Select Proceed to display the 'Interface details' menu.

## Input macro data

Input macro data should be used for complex interface calculations which have been put into a macro. The macro should contain only 261/262 options. When selected you will be requested to input the macro name and any variables.

### Input

IGINTET.DAT, INT006

Interface details
Input macro data
Simple single slope
Simple slope/berm
Rounded/standard slope
Add discontinuities (T)

## Simple single slope

A simple single slope is produced using automatic sections.

### Input

IGINTET.DAT, INT006, INT007

Interface details	Simple single slope
Input macro data	Level datum string label
Simple single slope	Cut width
Simple slope/berm	Cut gradient
Rounded/standard slope	Fill width
Add discontinuities (T)	Fill gradient

Select Proceed to create the interface string(s) and draw them on the picture.

Cut and/or fill strings are created depending upon whether the relevant width and gradient are specified.

## Simple slope/berm

A simple slope/berm is produced using automatic sections.

### Input

IGINTET.DAT, INT006, INT008

Interface details	Simple slope/berm
Input macro data	Level datum string label
Simple single slope	Slope width
Simple slope/berm	Slope gradient
Rounded/standard slope	Berm width
Add discontinuities (T)	Berm gradient

Select Proceed to create the interface string(s) and draw them on the picture.

## Rounded/standard slope

### Input

IGINTET.DAT, INT006, INT011

Interface details	Rounded/standard slope
Input macro data	Include cut slope (T)
Simple single slope	Include fill slope (T)
Simple slope/berm	Include cut ditch (T)
Rounded/standard slope	Apply slope rounding (T)
Add discontinuities (T)	

Select the type of interface you wish to produce by carrying out the following:

- Set the appropriate toggles on the rounded/standard slope menu.
- Select Proceed and fill in the required fields for each menu displayed.

The route taken through the subsequent menus is dependent upon which toggles are set but in general the following sequence is used:

Cut ditch  
 Cut slope  
 Fill slope  
 Rounding

If you do not set the toggle for any of the above, then the appropriate menu is skipped.

If you select Quit from any of the menus, you are returned to the 'Rounded/standard slope' menu.

When you have completed the last menu, select Proceed to perform the interface analysis and return to the 'Define strings' menu. The strings created will then be drawn and appear on the screen.

## Cut slope

This menu will only be displayed if the toggle 'Include cut slope' is set to YES in the 'Rounded/standard slope' menu.

### Input

IGINTET.DAT, INT013

Include cut slope
Slope rounding
Level datum string label
Std slope string label
Slope at start
Slope at end

**Slope rounding** is for information only.

**Level datum string label** identifies the level datum for the cut slope. If you have selected 'Cut ditch', the level datum string label in the 'Cut slope' menu is set by default to the outer edge string label.

If you have selected rounding, enter a **standard slope string label** if you wish to create the standard interface string in addition to the profile rounding strings.

If you have not selected rounding, the standard slope string label is set by default to the cut or fill string label specified in the 'Define strings' menu.

**Slope at start** is the gradient at the start of the cut slope.

**Slope at end** is the gradient at the end of the cut slope.

- ◇ *You may override the default values for slope by filling in the appropriate fields. Refer to the section 'Design standards for rounded/standard slopes' at the end of this chapter for details of the defaults used.*
- ◇ *If a constant gradient is required across the range, the slope at start and slope at end values should be the same.*



## Fill slope

This menu will only be displayed if the toggle 'Include fill slope' is set to YES in the 'Rounded/standard slope' menu.

### Input

IGINTET.DAT, INT015

Include fill slope
Slope rounding
Level datum string label
Std slope string label
Slope at start
Slope at end

**Slope rounding** is for information only.

**Level datum string label** identifies the level datum for the fill slope. If you have selected both 'Cut slope' and 'Fill slope', the level datum string label in the 'Fill slope' menu is set by default to the level datum string label specified in the 'Cut slope' menu.

If you have selected rounding, enter a **standard slope string label** if you wish to create the standard interface string in addition to the profile rounding strings.

If you have not selected rounding, the standard slope string label is set by default to the cut or fill string label specified in the 'Define strings' menu.

**Slope at start** is the gradient at the start of the fill slope.

**Slope at end** is the gradient at the end of the fill slope.

- ◇ *You may override the default values for slope by filling in the appropriate fields. Refer to the section 'Design standards for rounded/standard slopes' at the end of this chapter for details of the defaults used.*
- ◇ *If a constant gradient is required across the range, the slope at start and slope at end values should be the same.*

## Rounded ditches

This menu will only be displayed if both the toggles 'Include cut slope' and 'Include cut ditch' are set to YES in the 'Rounded/standard slope' menu.

### Input

IGINTET.DAT, INT012

Rounded ditches
Level datum string label
Outer edge string label
Ditch width
Ditch depth
Number of strings

**Level datum string label** identifies the level datum string and defines the inner edge of the ditch .

**Outer edge string label** defines the string at the outer edge of ditch.

The labels of the intermediate strings generated by the circular ditch option are derived from the label of the string at the outer edge of the ditch. The form of this label should be AANN+1 where AA are any two characters and NN is the number of intermediate strings.

**Ditch width** and **ditch depth** define the dimensions of the ditch. The depth of the ditch must not be greater than 50% of the width.

**Number of strings** is the number of intermediate strings to be generated excluding the level datum string and the ditch outer edge string.

- ◇ *If a cut ditch is required, a cut slope must also be specified.*
- ◇ *You may override the default values for ditch width and ditch depth by filling in the appropriate fields.*
- ◇ *For details of how cut ditches are generated, refer to Figure 8 - 83.*



## Add discontinuities

Adds a discontinuity between the last point of an interface string and the start of the next section where these two points do not coincide.

By default, discontinuities are included in the interface string.

### Input

IGINTET.DAT, INT006

Interface details
Input macro data
Simple single slope
Simple slope/berm
Rounded/standard slope
Add discontinuities (T)

## Major option INTERFACE - Linemode

Major option INTERFAC

1st Model 1 Model in which the interface is to be determined - usually the ground. If automatic sections through a triangulation model are used, then this must be the required triangulation model containing the triangulation string.

If stored sections are used this must be the ground section model.

2nd Model 2 Model containing the reference string from which the interface is determined and the level datum string. This will be the model in which the Interface String(s) and any strings through intermediate points on profiles will be stored.

### Global minor options

The global minor options 000, 017, 019, 900 and 999 may be used in INTERFAC.

## Minor option 259 Height criteria

Major option INTERFACE allows you to define alternative profiles and automatically selects a profile according to the height criteria you specify in the input data.

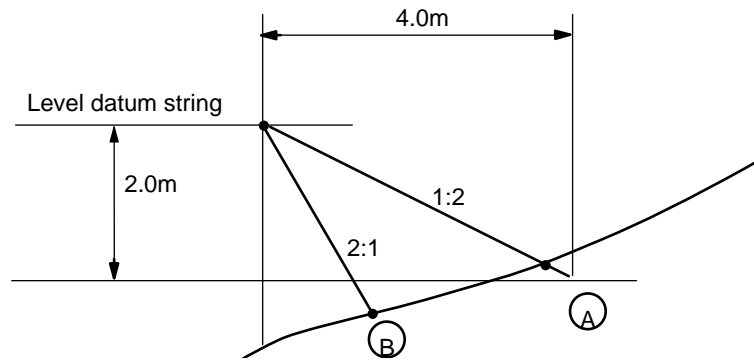
When creating an interface, you specify a width and a gradient for each element in each profile. These two values together correspond to a height measurement.

There are two different methods of specifying where the height is measured.

The first method calculates the height difference between the level datum string and the interface.

The second method calculates the height difference between the level datum string and a point vertically above or below.

For example, consider the two alternative profiles A and B in Figure 8 - 86.



**Figure 8 - 86 Vertical height criteria - simple case**

Using the first method, profile A is selected because the height difference between the level datum string and the intersection of the profile with the ground is less than 2m.

Using the second method, profile A is not considered because the height difference between the level datum string and the ground immediately below is greater than 2m. Profile B is therefore used.

### Input

#### Minor option 259

Field 1	Vertical height criteria indicator
INTI	Height difference between the level datum string and the interface (default).
DATM	Height difference between the level datum string and a point vertically above or below.

◇ *This option must precede minor option 260, 'Define strings'.*

Example

This example creates the interface strings A, B and C in Figure 8 - 87.

```
INTERFAC,GROUND MODEL,DESIGN MODEL
259,DATM
260,M001,IR01,,1
262,AUTO,VR01,5=4,7=-0.5
262,AUTO,VR01,5=9,7=-0.333
262,AUTO,VR01,7=-0.25
```

Using the second method (DATM), directly below the level datum string each of the three ground profiles lies in a different height band, so

- Slope A is generated for ground profile 1 (ie, less than 2m)
- Slope B is generated for ground profile 2 (ie, between 2m and 3m)
- Slope C is generated for ground profile 3 (ie, over 3m)

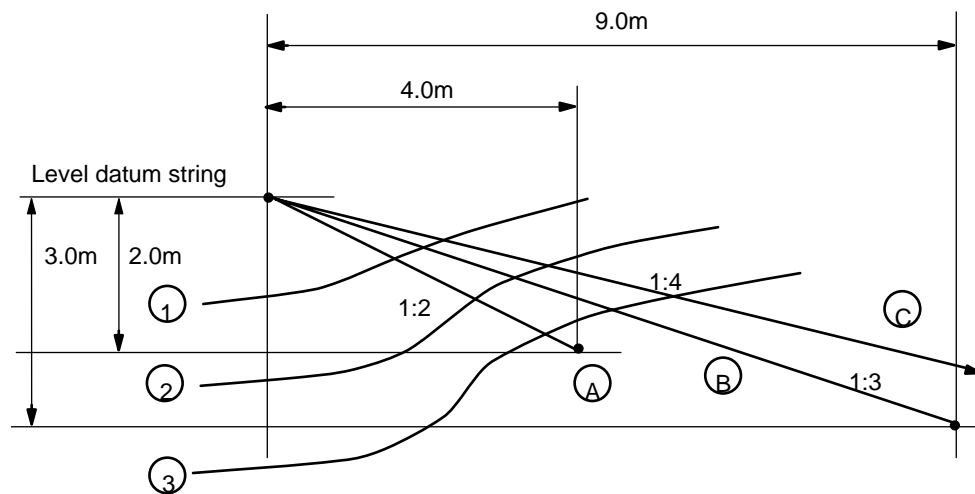


Figure 8 - 87 Vertical height criteria

If the first method (INTI) had been specified, at the end of slope A, ground profiles 1, 2 and 3 all lie within the first 2m height band and so slope A would be produced for any of the three ground profiles.

Minor option 260 Define strings

Define the reference string, the interface strings to be determined, the style of interface and the SPRD for its application.

Input

Minor option 260

- \* Field 1 Reference string on which the interface is based  
If stored sections are used they must have been determined relative to this reference string.

- Field 2 The label of the interface string for CUT strings.
- Field 3 The label of the interface string for FILL strings.
- Either field 2 or 3 may be left blank in which case the label from the non-blank field will be used for the vacant field. This has the same effect as entering the same label in both of these fields - the same string is used for cut and fill interfaces. It is incorrect to leave fields 2 and 3 blank.
- Field 4 Style of interface
- Interfacing to the right of the reference string using minor option order precedence:
- |         |                              |
|---------|------------------------------|
| 1 or 11 | forward 261's, forward 262's |
| 2 or 22 | reverse 261's, reverse 262's |
| 12      | forward 261's, reverse 262's |
| 21      | reverse 261's, forward 262's |
- Interfacing to the left of the reference string using minor option order precedence:
- |           |                              |
|-----------|------------------------------|
| -1 or -11 | forward 261's, forward 262's |
| -2 or -22 | reverse 261's, reverse 262's |
| -12       | forward 261's, reverse 262's |
| -21       | reverse 261's, forward 262's |
- Interfacing to the right of the reference string using shorter offset precedence:
- |           |                              |
|-----------|------------------------------|
| 91 or 911 | forward 261's, forward 262's |
| 92 or 922 | reverse 261's, reverse 262's |
| 912       | forward 261's, reverse 262's |
| 921       | reverse 261's, forward 262's |
- Interfacing to the left of the reference string using shorter offset precedence:
- |             |                              |
|-------------|------------------------------|
| -91 or -911 | forward 261's, forward 262's |
| -92 or -922 | reverse 261's, reverse 262's |
| -912        | forward 261's, reverse 262's |
| -921        | reverse 261's, forward 262's |
- Field 5 & 6 SPRD for start point on reference string
- Field 7 Limit on the number of profile points generated on any one section.
- This is set by default at 50 which will suffice for most jobs and therefore in most instances it will not be necessary to code this field. If required it can be set within the range 2-200 although setting this limit unnecessarily high may have a detrimental effect on processing time.
- Field 8 & 9 SPRD for end point on reference string.
- Field 10 A value of 1 invokes rounded/standard interfaces.

## Minor option 261, 262 Interface details

The data preparation for minor options 261 (cut strings) and 262 (fill strings) is similar and one description is used for both. Each set of records may contain the following record types:

- Stored or automatic sections
- Fixed level elements
- Mandatory elements
- Barrier strings

### Stored and automatic sections

Interface analysis may be carried out using stored sections, automatic sections or fixed level elements. Automatic sections can be taken through either a ground model or a triangulation. Each type of analysis applies to a full set of 261/262 records and need only be specified once between the 260 and 263 minor options.

Stored section analysis is invoked by specifying the stored section set reference character in Field 1. The referenced section set is assumed to apply to 261 or 262 records subsequent to the first unless a different entry is used in this field in these subsequent records.

Forward and reverse cases in single stratum interfacing require the same section set reference letter to apply to all 261/262 records. Multi-strata models use a different section set to model each stratum.

Automatic sectioning through the ground model is invoked by setting Field 1 to 'AUTO'. This will be assumed by default after the first occurrence. is invoked by setting Field 1 to 'AUTO'. This will be assumed by default after the first occurrence.

Automatic sectioning through a triangulation is invoked by specifying the triangulation string label in Field 1.

Interfacing to a fixed level may be carried out by setting Field 1 to 'LEVL'.

### Input

#### Stored and automatic sections

##### Minor option 261 or 262

- \* Field 1            Stored section set reference character  
                         or AUTO  
                         or LEVL  
                         or triangulation string label for auto sections through  
                         triangulation.
- ◇ *If a triangulation string is given, Model 1 must be a triangulation model. The exact points generated on the final interface string will provide greater definition than those generated using AUTO. The quality of the interface between these points can only be improved by generating an 'interface surface' and using isopachytes with the triangulation model.*



- Field 2 Label of the level datum string.
- Field 3 The string to which the element of the profile defined on this minor option is to be extended.  
If this is left blank then no string will be generated through this point on the cross section. Field 3 may also contain a partial string label when using repeat patterns. This is the first character defining the label of strings to be developed in a repeat pattern. If this field is coded with a partial label, then field 8 must also be coded. This defines the number of 261/262 records following and including the current one which constitute a repeat pattern.
- Field 4 The number of dimensions of the string created at the profile definition point.  
If this is left blank a 5D string will be created but a 3D string will be created if 3 is entered here.
- Field 5 Element width at start SPRD as defined in the immediately preceding 260 record.).  
The horizontal width of the element - if this is left blank a width of 1000 will be used to enable projection of this element to find the interface (ie stretchable element).
- Field 6 Surface adjustment height.  
This is only entered when it is required to vary a gradient at a fixed depth above or below ground surface as shown in the figure in worked example 9.
- Field 7 Gradient at the start of the range of application of the interface as defined by SPRD in the immediately preceding 260 record.  
This is specified as vertical component divided by horizontal component - not as a percentage.
- Field 8 The number of elements (n) in the pattern which is defined on this and the next n-1 261/262 records.  
This field is used only on the first 261/262 record which starts a repeat pattern. (see field 3 above).
- Field 9 Element width at end SPRD as defined in the immediately preceding 260 record or level to which the interface is to be calculated if LEVL is coded in field 1. If LEVL is specified in field 1 then field 9 contains the level at which the interface is to be found.
- Field 10 Gradient at the end of the range of application of the interface as defined by SPRD in the immediately preceding 260 record.  
This is specified as vertical component divided by horizontal component - not as a percentage.
- ◇ *For flat elements a gradient of 0 may be entered. INTERFACE changes this to a positive gradient of 0.001 to avoid numerical difficulties associated with trigonometrical functions and zero angles. For very wide slopes this effect may be noticed as a very small vertical component on*

*what was specified as a flat surface. This is unavoidable but has no practical significance.*

- ◇ *Variable width and variable gradient cannot be coded on the same record.*

## Mandatory elements

If the element of a profile defined on a particular 261/262 record is mandatory, all intersections with the ground on this element are ignored. Mandatory elements are specified using the ignore intersection indicator IGN in Field 1.

In multi-strata interfacing a fourth character may be appended to IGN to signify that the element is only to be included if an interface is found in the preceding stratum. See worked example 16 for further details.

## Input

### Mandatory elements

Minor option 261 or 262

- \* Field 1      IGN  
                  IGN Suffixed with any fourth character
- Field 2      Label of the level datum string.
- Field 3      The string to which the element of the profile defined on this minor option is to be extended.  
  
If this is left blank then no string will be generated through this point on the cross section. Field 3 may also contain a partial string label when using repeat patterns. This is the first character defining the label of strings to be developed in a repeat pattern. If this field is coded with a partial label then field 8 must also be coded. This defines the number of 261/262 records following and including the current one which constitutes a repeat pattern.
- Field 4      The number of dimensions of the string created at the profile definition point.  
  
If this is left blank a 5D string will be created but a 3D string will be created if 3 is entered here. See earlier section on this point.
- Field 5      Element width.  
  
The horizontal width of the element - if this is left blank a width of 1000 will be used to enable projection of this element to find the interface. (ie a stretchable element).
- Field 7      Gradient at the start of the range of application of the interface as defined by SPRD in the immediately preceding 260 record.  
  
This is specified as vertical component divided by horizontal component - not as a percentage.

- Field 8      The number of elements (n) in the pattern which is defined on this and the next n-1 261/262 records.  
This field is used only on the first 261/262 record which starts a repeat pattern. (see field 3 above).
- Field 10     Gradient at the end of the range of application of the interface as defined by SPRD in the immediately preceding 260 record. If this is entered and is different value from that in field 7 then a linear change of gradient will apply over the range.
- ◇ *For flat elements a gradient of 0 may be entered. INTERFACE changes this to a positive gradient of 0.001 to avoid numerical difficulties associated with trigonometrical functions and zero angles. For very wide slopes this effect may be noticed as a very small vertical component on what was specified as a flat surface. This is unavoidable but has no practical significance.*

## Barrier string

A barrier string is a string created in the interface profile which acts as a constraint to the interface. Once a string has been nominated as a barrier string, all strings between the barrier string and the level datum string are created.

A typical use of a barrier string would be in motorway design where the back of verge requires a positive crossfall in cut and a negative crossfall in fill. The back of verge must also be continuous. These conditions can be fulfilled by nominating the back of verge as a barrier string, which prevents the generated interface string from encroaching on the area between the barrier string and the level datum string.

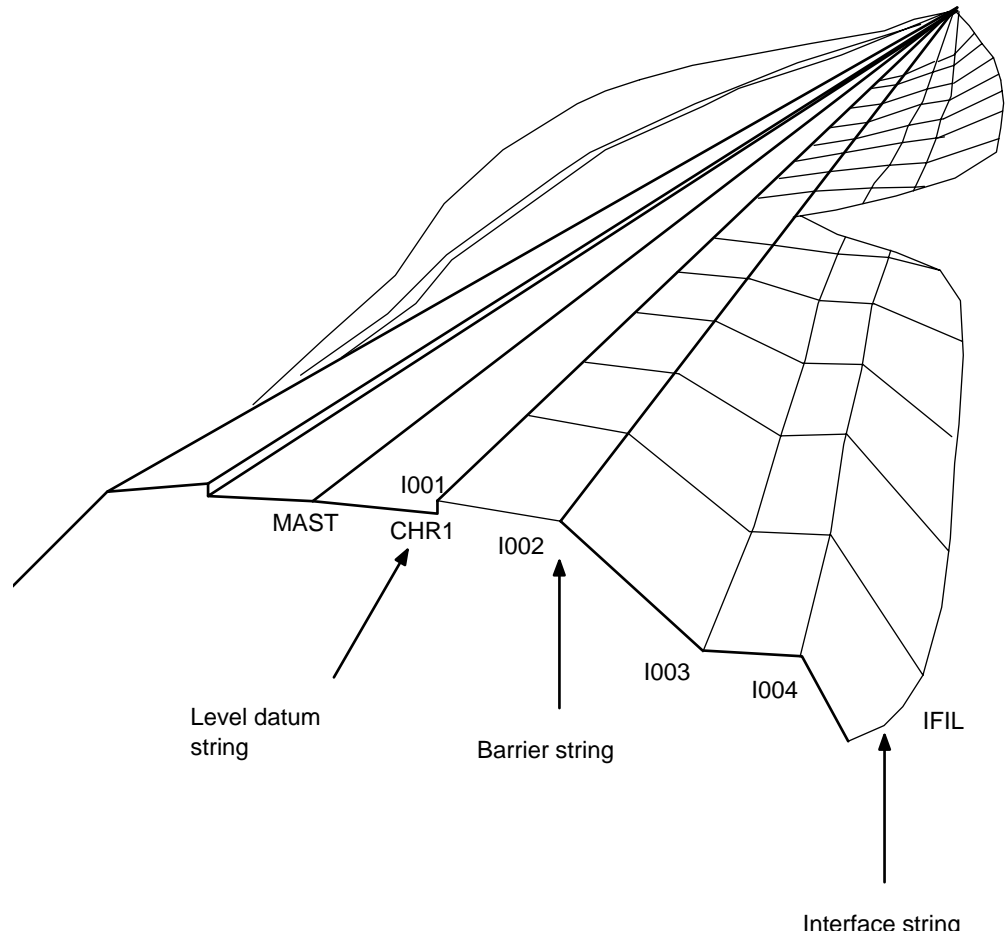
## Input

### Barrier string

#### Minor option 261 or 262

- \* Field 1      BARR
- Field 2      Label of the level datum string.
- \* Field 3      Label of barrier string.
- Field 4      The number of dimensions of the string created at the profile definition point.  
If this is left blank a 5D string will be created but a 3D string will be created if 3 is entered here.
- \* Field 5      Element width.  
The horizontal width of the element - if this is left blank a width of 1000 will be used to enable projection of this element to find the interface (ie stretchable element).
- \* Field 7      Gradient at the start of the range of application of the interface as defined by SPRD in the immediately preceding 260 record.

- This is specified as vertical component divided by horizontal component - not as a percentage.
- Field 10 Gradient at the end of the range of application of the interface as defined by SPRD in the immediately preceding 260 record. This is specified as vertical component divided by horizontal component - not as a percentage.
- ◇ *Only one barrier string is allowed per set of 261/262 minor options.*
  - ◇ *Barrier strings can only be created with the forward analysis style of interface.*
  - ◇ *All strings between the barrier string and level datum string are continuous and should be coded separately for cut and fill with IGN in Field 1. If a single string is required at a particular offset from the level datum string, use the same label for both cut and fill.*
  - ◇ *Any string following the barrier string can have either the same or different labels for cut and fill.*
  - ◇ *For flat elements a gradient of 0 may be entered. INTERFACE changes this to a positive gradient of 0.001 to avoid numerical difficulties associated with trigonometrical functions and zero angles. For very wide slopes this effect may be noticed as a very small vertical component on what was specified as a flat surface. This is unavoidable but has no practical significance.*



**Figure 8 - 88 Interface with barrier string**

## Cut ditch

### Input

#### Cut ditch

Minor option 261 or 262

Field 1 CIRC

Field 2 Label of the level datum string.

Field 3 Label of string at outer edge of ditch

The labels of the intermediate strings generated by the circular ditch option are derived from the label of the string at the outer edge of the ditch. The form of this label should be AANN+1 where AA are any two characters and NN is the number of intermediate strings, as defined in Field 8.

Field 4 The number of dimensions of the intermediate strings being generated (default = 5).

Field 5 Width of ditch

Field 6 Depth of ditch

The depth of the ditch must not be greater than 50% of the width.

Field 8 Number of strings to be generated excluding the level datum string and the ditch outer edge string.

◇ *Field 10 in minor option 260 Define strings must be set to 1 before this option is used.*

## Cut/fill slope

Standard slopes are invoked by setting Field 10 in the preceding 260 Define string record to 1.

### Input

#### Cut/fill slope

Minor option 261 or 262

Field 1 Stored section set reference character or AUTO or triangulation string label for auto sections through triangulation.

Field 2 Label of the level datum string

Field 2 Label of the level datum string.

Field 3 Label of standard slope string.

If this label is specified, the standard slope string is created in addition to the strings created by the rounding process. This is only relevant if a 264 record is to follow to invoke rounding.

- Field 4      The number of dimensions of the interface string (default = 5).
- Field 7      Gradient at the start of the range of application of the interface as defined by SPRD in the immediately preceding 260 record. This is specified as vertical component divided by horizontal component - not as a percentage. If this field is left blank, the standard design gradient is used
- Field 10     Gradient at the end of the range of application of the interface as defined by SPRD in the immediately preceding 260 record. If this is entered and is different value from that in field 7 then a linear change of gradient will apply over the range. If this field is left blank, the standard design gradient is used
- ◇ *If a constant gradient is required across the range, fields 7 and 10 should have the same value.*
  - ◇ *Only one non-IGN record is allowed per set of 261 and 262 standard interface minor options.*
  - ◇ *If rounding is required on a standard slope, minor option 264 should be specified following the 261/262 record set. If rounding is not required, no 264 is necessary and only a single interface string is generated.*
  - ◇ *Field 10 in minor option 260 Define strings must be set to 1 before this option is used.*

## **Minor option 263    Invoke interface analysis**

The 263 minor option invokes the interface analysis using all data defined on the minor options between the preceding 260 minor option. The models used are those on the preceding INTERFACE major option.

### **Input**

#### **Minor option 263**

- Field 1      Discontinuity indicator  
               DISC - include discontinuities  
               NODI - exclude discontinuities  
               Discontinuities are included or excluded in interface strings when the last point of the interface string is not coincident with the start of the next section.

## **Minor option 264    Invoke rounding**

Minor option 264 indicates that parabolic rounding is to be carried out.

**Input**

Minor option 264

- Field 3      Initial character to be used for labelling the intermediate strings used to describe the parabola.  
The final string is given the label specified in field 3 of the 260 record.
- Field 4      The number of dimensions of the generated strings (default = 5)
- Field 5      Tangent length at the start of the range of application of the interface as defined by SPRD in the immediately preceding 260 record.  
If this field is left blank, the standard tangent length is used.
- Field 6      Tangent length at the end of the range of application of the interface as defined by SPRD in the immediately preceding 260 record.  
If this field is left blank, the standard tangent length is used.
- Field 8      Number of intermediate strings to be generated
  - ◇ *If a constant tangent length is required across the range, fields 5 and 6 should have the same value.*
  - ◇ *Field 10 in minor option 260 Define strings must be set to 1 before this option is used.*
  - ◇ *Only one initial character can be specified in Field 3.*

**Output from major option INTERFACE**

The output from the INTERFACE major option is a commentary on the interface strings and the associated strings as they are created. This output, whilst helpful, is not a substitute for using the REPORT major option on these strings which is the only way of obtaining the fullest information. The commentary only includes interface points at the sections at which they are generated but does include warnings of how many extra points are included because of interpolation at transitions.

The general form of output is shown in the example below. The tables in section 1 are reported for the 261 and 262 options - there is one line in each table for each of the relevant minor options. The output comprises:-

OPTION	261 OR 262
SECTION	The section set letter relevant to this minor option or AUTO if automatic sections are used.
START	The string label at the start of this element of the profile. A sequential number if no label has been given.
END	The string label at the end of this element of the profile. This is a sequential number if no label has been given



	or '++++' when the element is the last on the profile and the end point will be the interface point.
WIDTH	Width of element.
ST-OFF	The offset of the start point of the element. This is measured from the level datum string.
END-OFF	The offset of the end point of the element - again measured from the level datum string.
ST-SLOPE	The gradient of the element at the start of the application.
END-SLOPE	The gradient of the element at the end of the application.
3D/5D	The number of dimensions which will be assigned to the string at the end of the application.

◇ *When using reverse style the elements in this table are rearranged from the order in which they were entered to correspond to the order in which they are processed within INTERFACE for this style.*

Section 2 of the output is a report of the style of the interface and the labels of the reference strings and the interface strings. Where the same label is reported for both the cut and fill interface strings the string of that label will contain both cut and fill interface points.

Section 3 of the output is a table headed:-

**INTERFACE PRIMARY ANALYSIS**

This table gives a commentary on the interface string(s) as they are created. The table is different from a report of a string in that, in most cases, two interface strings will be intermeshed in the table - the cut (261) string and the fill (262) string.

The contents of the table are as follows:-

SECTION	This is the section reference at which the point on the interface is produced. When using stored sections this will be the section letter referenced in the 261 or 262 minor options plus the 3 character reference for the section at this point. When using automatic sections the internally generated section reference will be listed here. When Interfacing to a fixed level 'LEVL' is listed.
CHAINAGE	Chainage at which the section is produced. If the reference string is not a master alignment string then the heading and contents of this column of the table are omitted.
X, Y, Z	The coordinates of the interface point at this section.
OFFSET	The offset of the interface point measured from the level datum string. If this value is suffixed with the letter E then the ground section has had to be extended at this section to find the interface.
PTS	The number of points across the profile including the level datum string point and the interface point. This is

particularly helpful when, for instance, berms are not present at some sections where there is inadequate depth of fill to warrant them. This would be indicated by variations in the value in this column.

C/F

C (Cut; 261 Minor option

F (Fill - 262 Minor option)

This column shows the normal cut/fill condition of the interface point, thus indicating the string into which the point will be placed. A point generated on an element defined by 261 minor options will have a C in this column and will be written to the CUT interface string as defined by 260 minor option. A point generated on an element defined by 262 minor options will have an F in this column and will be written to the FILL interface string as defined on the 260 minor option.

In most cases the output will be followed by a number of warning messages. The purpose of these is to alert the user to the following:-

- Extra points will have been generated on the Interface at zero cut/fill points and by the truncation of intermediate strings as explained above. These points will not be in the primary analysis table and their inclusion in the string can only be seen from use of the REPORT major option.
- Points will be generated on strings passing through intermediate points on the profile which have been given labels in the 261/262 options. This is reported on the output for each string on which points are created.

## Worked examples

A series of worked examples is given to demonstrate the wide range of applications for this major option.

The examples are as follows:-

1. Simple interfaces.
2. Multi-element profiles.
3. Cutting with a ditch at its foot.
4. Fill conditions with benching.
5. Alternative slopes - simple case.
6. Multi-element profiles in conjunction with alternative slopes.
7. Steeper slopes with increasing depth.
8. Multi-element profiles with alternate vertical offsets to give transition of equal horizontal offset.
9. Gradient change at specific depth below ground.
10. Use of subgrade-road profile intersection for interfacing.
11. Embankments with ditches at specified hydraulic gradients.
12. Ditch at back of verge.

13. Multi-strata interfaces using successive single strings.
14. Multi-strata interfaces using alternative single slopes.
15. Multi-strata interfaces using using multi-element profiles.
16. Multi-strata, multi-elements, cutback condition.
17. A complex multi-strata example.
18. Interfacing to a fixed level.
19. Repeat patterns.
20. Repeat patterns in multi-strata.
21. Simple interface with no rounding - German standards
22. Simple interface with rounding - German standards
23. Stored simple interface with rounding - German standards
24. Interface with non-uniform rounding - German standards
25. Interface with cut/fill comparison
26. Interface with barrier string

In these examples data is shown between the INTERFACE major option and the 263 minor option. A mixture of automatic sections and stored sections has been used. The model names used are:-

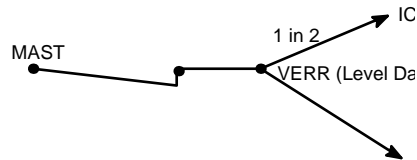
GROUNDMODEL	Containing the model of the ground (auto sections) or the ground cross sections (stored sections).
NEWWORKMODEL	Containing the model which includes the reference string and the level datum string and into which the interface strings will be filed.
HYDRAULICMODEL	Used to contain the model of hydraulic surface when this is used.

The 260 minor options always reference two separate interface strings for cut and fill. The reference string is always MAST in NEWWORKMODEL and generally examples run between chainages 10 and 100 defined by SPRD.

The more complex examples omit the inappropriate cut/fill condition for clarity - this is indicated on the comments which precede each of the examples. The labels for all generated strings start with the letter I but this is convention only and is not mandatory.

**Example 1 Simple interface**

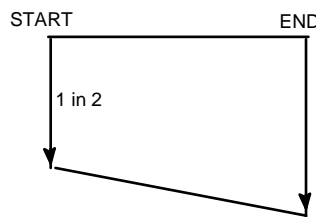
- This is an example of the most straightforward use of INTERFACE where a single element is extended from the level datum string to the ground model.
- Although the gradients have the same value (apart from sign) in cut and fill (261/262) they may be different.
- The gradient at the end of the range of the application may be different from that at the beginning. The range of the application is defined via SPRD on the 260 minor option. The gradient at an intermediate point along the application will be linearly interpolated between that at the beginning and that at the end.
- It would not be appropriate to consider this case in reverse style.



**Figure 8 - 89 Example 1a - Simple interfaces - cross section**

```

EXAMPLE 1a SIMPLE INTERFACES
AUTOMATIC SECTIONS - CONSTANT SLOPE
INTERFAC, GROUNDMODEL, NEWWORKMODEL
260, 1=MAST, 2=IC01, 3=IF01, 4=1, 5=10, 8=100
261, 1=AUTO, 2=VERR, 7=0.5
262, 2=VERR, 7=-0.5
263
    
```



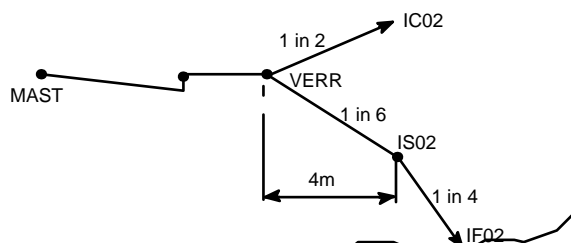
**Figure 8 - 90 Example 1b - Simple interfaces - plan**

```

EXAMPLE 1b
STORED SECTIONS - VARYING SLOPE
INTERFAC, GROUNDMODEL, NEWWORKMODEL
260, 1=MAST, 2=IC01, 3=IF01, 4=1, 5=10, 8=100
261, 1=G, 2=VERR, 7=0.5, 10=0.33
262, 1=G, 2=VERR, 7=-0.5, 10=-0.33
263
    
```

**Example 2 Multi-element profiles**

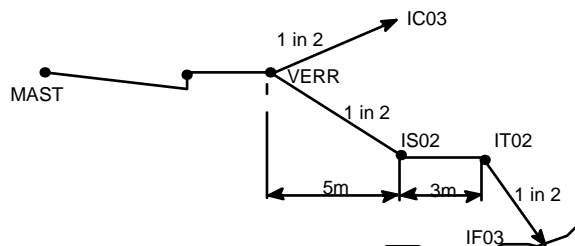
- This example shows how profiles with several different elements may be specified so that features such as berms and ditches may be included.
- INTERFACE will determine those elements of the profile to be included by consideration of depth of cut or fill criteria. Contrast this with examples 5, 6 and 7 where INTERFACE selects complete alternative slopes according to depth of cut or fill criteria.
- Note that strings will be generated at each intermediate point where a label is specified.
- The reverse case is highly pertinent here as described in earlier section.



**Figure 8 - 91 Example 2a Broken back slopes**

```

EXAMPLE 2a MULTI-ELEMENT PROFILES
BROKEN BACK SLOPES-AUTO SECTIONS
INTERFAC, GROUNDMODEL, NEWWORKMODEL
260, 1=MAST, 2=IC02, 3=IF02, 4=1, 5=10, 8=100
261, 1=AUTO, 2=VERR, 7=0.5
262, 2=VERR, 3=IS02, 5=4.0, 7=-0.16
262, 7=-0.25
263
    
```

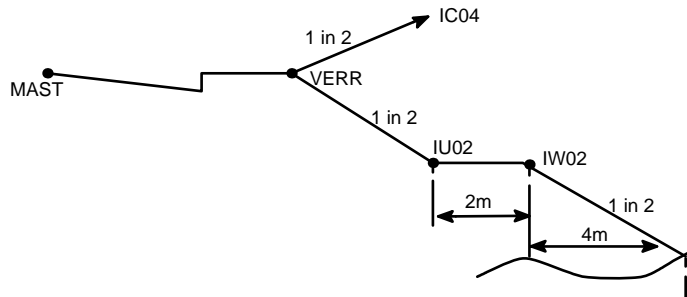


**Figure 8 - 92 Example 2b Reverse style**

```

EXAMPLE 2b
FILL SLOPES WITH BERM - FORWARD STYLE -
STORED SECTION SET G
INTERFAC, GROUNDMODEL, NEWWORKMODEL
260, 1=MAST, 2=IC03, 3=IF03, 4=1, 5=10, 8=100
261, 1=G, 2=VERR, 7=0.5
262, 2=VERR, 3=IS02, 5=5, 7=-0.5
    
```

```
262,3=IT02,4=3,5=3,7=0
262,7=-0.5
263
```

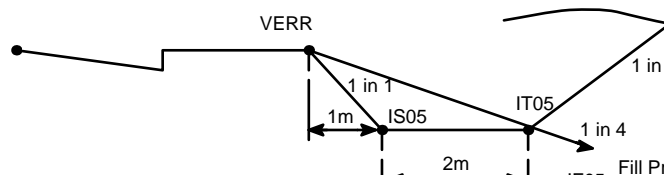


**Figure 8 - 93 Example 2c Multi-element profiles**

```
EXAMPLE 2c
FILL SLOPES WITH BERM - REVERSE STYLE - AUTO
SECTIONS
INTERFAC, GROUNDMODEL, NEWWORKMODEL
260,MAST,2=IC04,3=IF04,4=12,5=10,8=100
261,1=AUTO,2=VERR,7=0.5
262,2=VERR,3=IU02,7=-0.5
262,3=IW02,4=3,5=2,7=0
262,5=4,7=-0.5
263
```

**Example 3 Cutting with ditch at its foot**

- This example shows the use of the IGN, ignore intersection indicator to produce a ditch when point IT05 is in cut.
- The priority profile for this cutting condition will have to be specified first on a 261 minor option. This will prevent an embankment condition being used where the profile extends directly from the level datum string which could be defined on a subsequent 262 record.
- The plan below shows how the strings will be trimmed when the scheme goes from cut to fill and the profile defined on 261 record(s) is replaced by that on 262 record(s). Points will be added to the Interface string and the strings on the bed of the ditch if these have been labelled as discussed previously.
- The reverse case is not appropriate as shown because the example is similar to example 1 above if the elements with IGN are considered as fixed elements of the profile.



**Figure 8 - 94 Example 3 Cutting with ditch at its foot**

```

EXAMPLE 3 CUTTING WITH DITCH AT ITS FOOT
CUT SLOPES - STORED SECTION SET G
INTERFAC, GROUNDMODEL, NEWWORKMODEL
260, 1=MAST, 2=IC05, 3=IF05, 4=1, 5=10, 8=100
261, 1=IGN, 2=VERR, 3=IS05, 5=1, 7=-1
261, 1=IGN, 2=IS05, 3=IT05, 4=3, 5=2, 7=0
261, 1=G, 2=IT05, 7=1
262, 2=VERR, 7=-0.25
263
    
```

itch

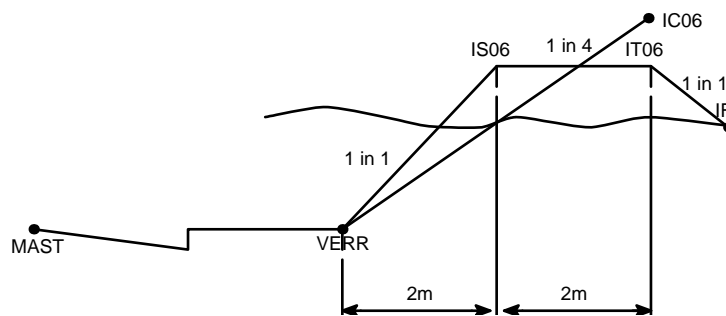
tum

**Figure 8 - 95 Example 3 string trimming – transition cut to fill**



**Example 4 Fill conditions with benching**

- This example is similar but opposite to that shown in example 3. Here the IGN indicator is used to generate the benching when point IT06 is in fill.
- Again the order of minor options is crucial but the fill profile defined on 262 minor options must take precedence over cut profile on 261s. This is to prevent the use of unwanted cut profile extending from the level datum string. The 262 minor options must precede the 261s in the data.
- The plan below shows how the strings will be trimmed as the scheme passes from fill to cut.
- The reverse case is not appropriate as shown because the example is similar to example 1 above if the elements with IGN are considered as fixed elements of the profile.



**Figure 8 - 96 Example 4 Fill conditions with benching**

```

EXAMPLE 4 FILL CONDITIONS WITH BENCHING
FILL SLOPES - AUTOMATIC SECTIONS
INTERFAC, GROUNDMODEL, NEWWORKMODEL
260, 1=MAST, 2=IC06, 3=IF06, 4=1, 5=10, 8=100
262, 1=IGN, 2=VERR, 3=IS06, 5=2, 7=1
262, 1=IGN, 3=IT06, 4=3, 5=2, 7=0
262, 1=AUTO, 7=-1
261, 2=VERR, 7=0.25
263
    
```

bench

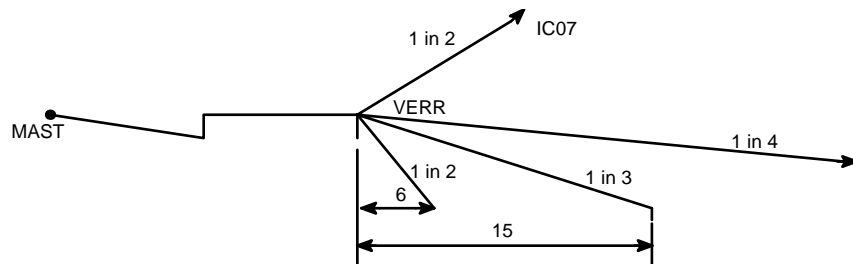
atum

||

**Figure 8 - 97 Example 4 string trimming – transition fill to cut**

**Example 5 Alternative slopes - simple case**

- This is the first of the examples where INTERFACE calculates the elements to be used according to the depth of cut or fill.
- The use of the profile element is determined by reference to width criteria - which, in turn, defines depth of cut or height of fill.
- It is not advisable to have varying gradient across a range of application when using alternative slopes - ie a gradient should be specified in field 7 but no gradient given in field 10 on the 261/262 record.
- It is not appropriate to use the reverse style here.



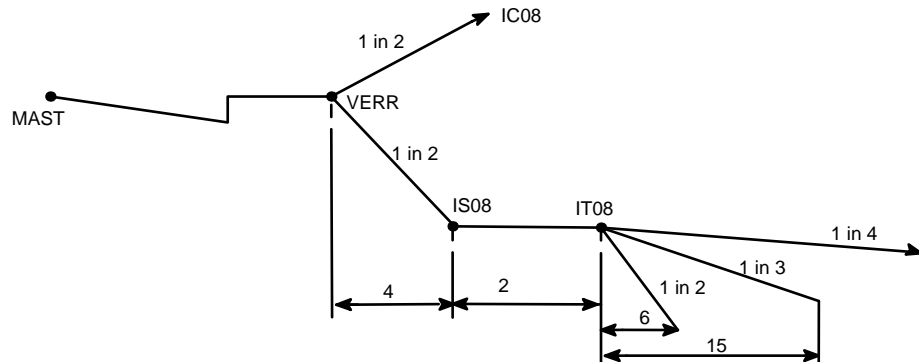
**Figure 8 - 98 Example 5 Alternative slopes - simple case**

```

EXAMPLE 5 ALTERNATIVE SLOPES SIMPLE CASE
ALTERNATIVE FILL SLOPES - STORED SECTION SET G
INTERFAC, GROUNDMODEL, NEWWORKMODEL
260, 1=MAST, 2=IC07, 3=IF07, 4=1, 5=10, 8=100
261, 1=G, 2=VERR, 7=0.5
262, 2=VERR, 5=6, 7=-0.5
262, 2=VERR, 5=15, 7=-0.33
262, 2=VERR, 7=-0.25
263
    
```

**Example 6 Multi-element profiles in conjunction with alternative slopes**

- This example shows the use of a profile incorporating a berm where the alternative slopes are used outside the outer element of the berm using width criteria defined from this latter point as described for example 5 above.



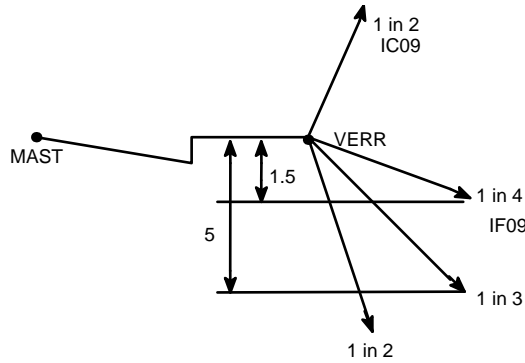
**Figure 8 - 99 Example 6 Multi-element profiles in conjunction with alternative slopes**

```

EXAMPLE 6 MULTI-ELEMENT PROFILES IN CONJUNCTION
WITH ALTERNATIVE SLOPES
SIMPLE CUT SLOPE - MULTI ELEMENT FILL SLOPES
- AUTOMATIC SECTIONS
INTERFAC, GROUNDMODEL, NEWWORKMODEL
260, 1=MAST, 2=IC08, 3=IF08, 4=1, 5=10, 8=100
261, 1=AUTO, 2=VERR, 7=0.5
262, 2=VERR, 3=IS08, 5=4, 7=-0.5
262, 2=IS08, 3=IT08, 4=3, 5=2, 7=0
262, 2=IT08, 5=6, 7=-0.5
262, 2=IT08, 5=15, 7=-0.33
262, 2=IT08, 7=-0.25
263
    
```

**Example 7 Steeper slopes with increasing depth**

- This is a variation on example 5 showing how INTERFACE can be used to specify steeper slopes with increasing depth of cut or height of fill.
- There is intrinsically no difference between this and example 5 and the reverse case is inappropriate here.



**Figure 8 - 100 Example 7 Steeper slopes with increasing depth**

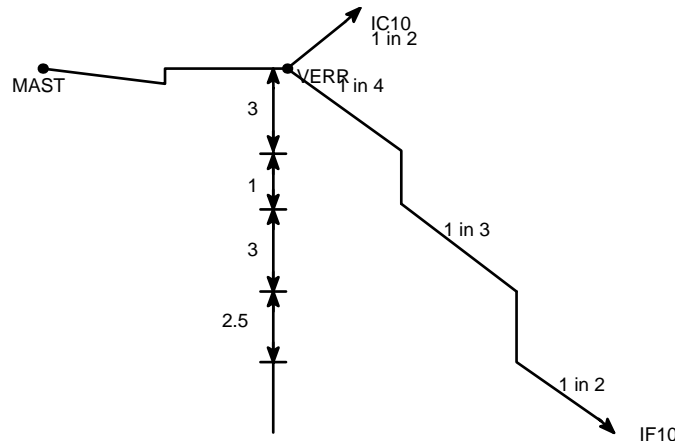
EXAMPLE 7 STEEPER SLOPES WITH INCREASING DEPTH  
SINGLE CUT SLOPE - ALTERNATIVE FILL SLOPES  
- STORED SECTION SET G

```

INTERFAC, GROUNDMODEL, NEWWORKMODEL
260, 1=MAST, 2=IC09, 3=IF09, 4=1, 5=10, 8=100
261, 1=G, 2=VERR, 7=0.5
262, 2=VERR, 5=6, 7=-0.25
262, 2=VERR, 5=15, 7=-0.33
262, 2=VERR, 7=-0.5
263
    
```

**Example 8 Transition slope of equal horizontal offset**

This is an example where it is required to have earthworks of constant width between defined slopes. Because of the omission of labels for intermediate strings no berms are provided. The slope when the interface is found in the 'transition' (ie between 3 and 4 metres below the level datum string in the example above) will vary. However, it is in all cases a plane slope between the level datum string and the interface.



**Figure 8 - 101 Example 8 Transition slope of equal horizontal offset**

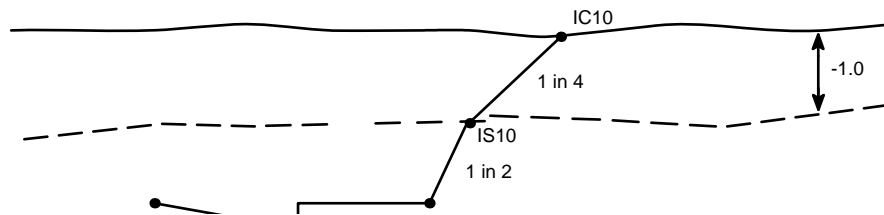
EXAMPLE 8 TRANSITION SLOPE OF EQUAL HORIZONTAL  
OFFSET SINGLE CUT SLOPE - MULTI ELEMENT FILL SLOPE  
AUTOMATIC SECTIONS

```

INTERFAC, GROUNDMODEL, NEWWORKMODEL
260, 1=MAST, 2=IC10, 3=IF10, 4=1, 5=10, 8=100
261, 1=AUTO, 2=VERR, 7=0.5
262, 2=VERR, 5=12, 7=-0.25
262, 5=0.001, 7=-1000
262, 5=9, 7=-0.33
262, 5=0.001, 7=-2500
262, 5=-0.5
263
    
```

**Example 9 Gradient change at specific depth above or below ground**

- This example shows how the gradient may be modified at a fixed depth below ground.
- This is in fact a simplified version of multi-strata interfacing (which follows) allowing depth dependent criteria to be set without setting up multiple section sets.
- This situation can also apply with embankments where the depth specified could be that of a layer of unsuitable material.



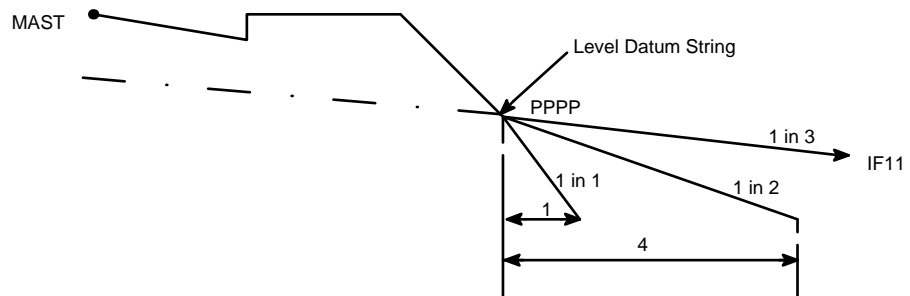
**Figure 8 - 102 Example 9 Gradient change at specific depth above or below ground**

```

EXAMPLE 9 GRADIENT CHANGE AT SPECIFIC DEPTH BELOW
GROUND CUT SLOPES ONLY SHOWN FOR CLARITY
STORED SECTION SET G
INTERFAC, GROUNDMODEL, NEWWORKMODEL
260, 1=MAST, 2=IC10, 4=1, 5=10, 8=100
261, 1=G, 2=VERR, 6=-1.0, 7=0.5
261, 2=IS10, 7=0.25
263
    
```

**Example 10 Use of subgrade-road profile intersection for interfacing**

- This example shows how the intersection point of the subgrade (formation) and the road profile may be used as the level datum string for interfacing.
- This point, PPPP in the diagram, could be defined by a DESIGN option prior to its use as the level datum string for Interfacing, or could be developed by INTERFACE itself.
- All interface facilities may be used in this case.



**Figure 8 - 103 Example 10 Use of subgrade-road profile intersection for interfacing**

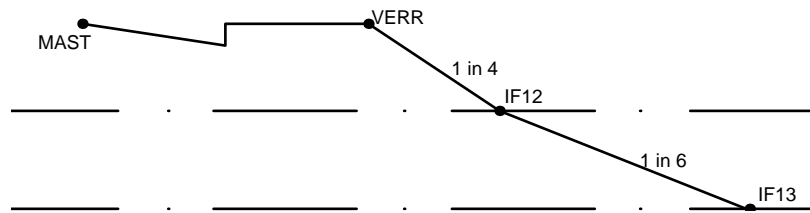
```

EXAMPLE 10 USE OF SUBGRADE-ROAD SURFACE
INTERSECTION FOR INTERFACING FILL SLOPES ONLY
SHOWN FOR CLARITY - AUTOMATIC SECTIONS
INTERFAC,GROUNDMODEL,NEWWORKMODEL
260,MAST,3=IF11,4=1,5=10,8=100
262,1=AUTO,2=PPPP,5=1,7=-1
262,2=PPPP,5=4,7=-0.5
262,2=PPPP,7=-0.33
263
    
```



**Example 11 Embankments with ditches at specified hydraulic gradients**

- These examples show how INTERFACE may be used to develop ditches at the foot of embankments and how these ditches may be run at specific hydraulic gradients.
- In the first example INTERFACE is used at least twice. Firstly the required embankment is projected from the first level datum string (chosen as the back of verge in this case) to the ground. The interface string thus generated is used as the level datum string for the second interfacing to the hydraulic surface which will have been generated earlier by DESIGN or other methods. The gradient in this case is that of the side of the ditch. The outer point of the ditch can be defined by DESIGN and a further INTERFACE carried out to determine the intersection of the outer side of the ditch with the ground. Alternatively IGN could be used on the bed of the ditch to achieve the same end.
- The second situation shows how the reverse style can be used to position a berm at a fixed height above the bed of the ditch. This is done by interfacing in reverse style directly to the hydraulic surface. Note however that if this is done there will be no intersection with the ground which may cause difficulties if the interface strings are to be used in volumetric calculations. This is resolved if the ditch is completed with the interface string.



**Figure 8 - 104 Example 11a Embankments with ditches at specified hydraulic gradients**

EXAMPLE 11 EMBANKMENT WITH DITCHES AT SPECIFIED HYDRAULIC GRADIENTS

EXAMPLE 11A - FORWARD - INTERFACE SEPARATE MODELS FOR GROUND AND HYDRAULIC SURFACES - AUTOMATIC SECTIONS INTO EACH -

FILL SLOPES ONLY SHOWN FOR CLARITY

INTERFAC, GROUNDMODEL, NEWWORKMODEL

260, MAST, 3=IF12, 4=1, 5=10, 8=100

262, AUTO, VERR, 7=-0.25

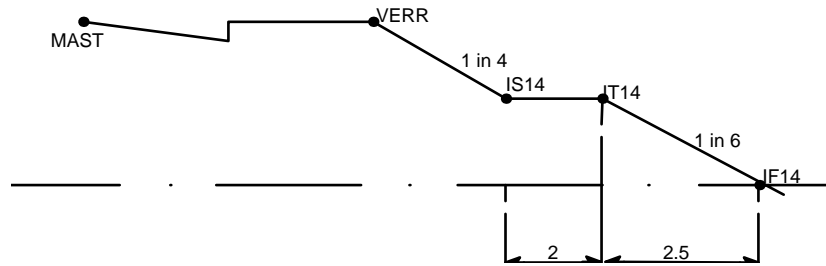
263

INTERFAC, HYDRAULICMODEL, NEWWORKMODEL

260, MAST, 3=IF13, 4=1, 5=10, 8=100

262, AUTO, IF12, 7=-0.166

263

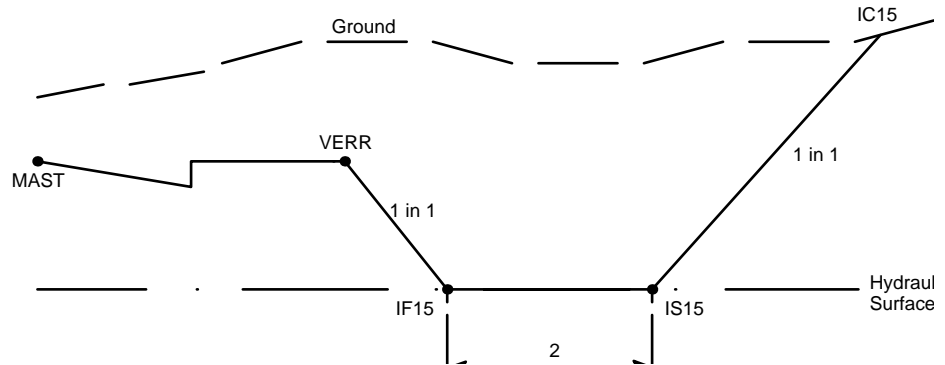


**Figure 8 - 105 Example 11b Embankments with ditches at specified hydraulic gradients**

EXAMPLE 11B - REVERSE INTERFACE - FILL SLOPE ONLY  
 SHOWN FOR CLARITY - AUTOMATIC SECTIONS  
 INTERFAC, HYDRAULICMODEL, NEWWORKMODEL  
 260, MAST, 3=IF14, 4=2, 5=10, 8=100  
 262, AUTO, VERR, 3=IS14, 7=-0.25  
 262, 2=IS14, 3=IT14, 4=3, 5=2, 7=0  
 262, 2=IT14, 5=2.5, 7=-0.166  
 263

**Example 12 Ditch at back of verge**

- This is a variation on those shown in example 11 when a ditch is required at the back of verge, the bed of the ditch to follow a hydraulic gradient longitudinally and not the design vertical alignment.



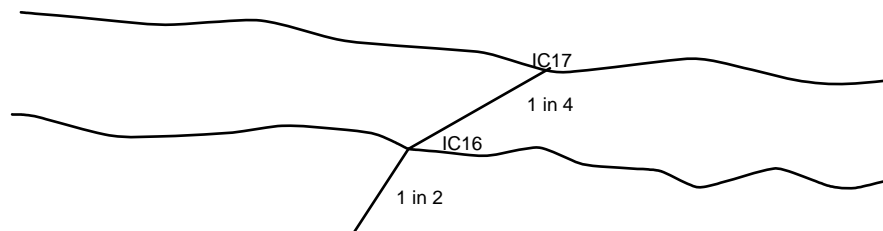
**Figure 8 - 106 Example 12 Ditch at back of verge**

```

EXAMPLE 12 - DITCH AT BACK OF VERGE
SEPARATE MODELS USED FOR GROUND AND HYDRAULIC
SURFACES AUTOMATIC SECTIONS USED IN BOTH
INTERFAC, HYDRAULICMODEL, NEWWORKMODEL
260, MAST, 3=IF15, 4=1, 5=10, 8=100
262, AUTO, VERR, 7=-1
263
999
INTERFAC, GROUNDMODEL, NEWWORKMODEL
260, MAST, 2=IC15, 4=1, 5=10, 8=100
261, IGN, IF15, IS15, 4=3, 5=2, 7=0
261, AUTO, 7=1
263
    
```

**Example 13 Multi-strata interfaces using successive single interfaces**

- This shows a basic use of the multi-strata interface to generate a string where the profile cuts a stratum. Contrast this with the later examples which shows how INTERFACE can be used to project profiles through multi-strata ground to develop the interface with the ground surface.
- The commentary on this type of interface will mark it as FORWARD rather than MULTI-STRATA as only one section set at a time is involved.
- This method can be used repeatedly if necessary to produce an interface string at the intersection with each stratum using the previously generated interface string as the level datum string.



**Figure 8 - 107 Example 13 Multi-strata interfaces using successive single interfaces**

```

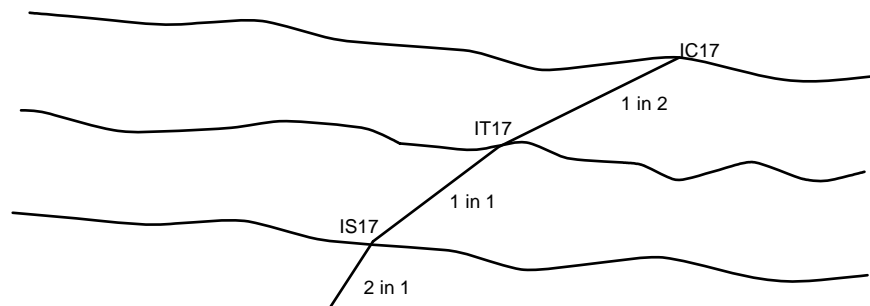
EXAMPLE 13 - MULTI-STRATA INTERFACES USING
SUCCESSIVE SINGLE INTERFACES
CUT SLOPES ONLY SHOWN FOR CLARITY
MANDATORY STORED SECTION SETS (C AND G) USED
INTERFAC,GROUNDMODEL,NEWWORKMODEL
260,MAST,IC16,4=1,5=10,8=100
261,C,VERR,7=0.5
263
260,MAST,IC17,4=1,5=10,8=100
261,G,IC16,7=0.25
263

```

**Example 14 Multi-strata interfaces using successive single slopes**

This style is used when interfacing into models where several strata are defined. This style enables different elements to be used in the different strata of the model.

- This example shows the use of INTERFACE to determine the elements to be used according to the stratum through which the profile passes.
- Models of the different strata are developed and sections taken through each (using the SECTION major option). The sections through each of the strata will be given a different section set character.
- All sets of stored sections used in multi-strata interfacing must be in the same model. They must have been generated across the same reference string, which will be the string in Field 1 of the minor option 260.
- Note the reverse style may not be used in this or other cases of multi-strata interfacing.



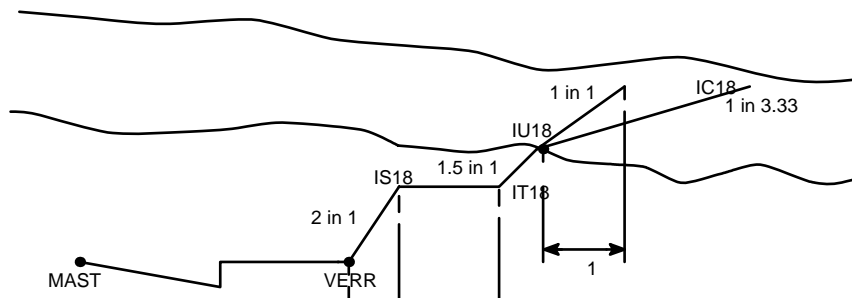
**Figure 8 - 108 Example 14 Multi-strata interfaces using successive single slopes**

```

EXAMPLE 14 - MULTI STRATA INTERFACES SUCCESSIVE
SINGLE SLOPES CUT SLOPES ONLY SHOWN FOR CLARITY
MANDATORY STORED SECTION SETS (G, B AND C USED)
INTERFAC, GROUND MODEL, NEW WORK MODEL
260,1=MAST,2=IC17,4=1,5=10,8=100
261,1=C,2=VERR,3=IS17,7=2
261,1=B,2=IS17,3=IT17,7=1
261,1=G,2=IT17,7=0.5
263
    
```

**Example 15 Multi-strata interfaces using multi-element profiles**

- This example shows how a multi-element portion of a profile may be introduced within a single stratum.
- This is in essence the same as the previous examples but special action is taken in the case shown below. The data for that portion of the profile in stratum B requires a berm to be placed when the level datum string is in this stratum. However the levels can be such that the berm would be in stratum A. In this case the berm is not used and the profile is generated as shown in Figure 8 - 109.



**Figure 8 - 109 Example 15 Multi-strata interfaces using multi-element profiles**

EXAMPLE 15 - MULTI-STRATA INTERFACES MULTI ELEMENT PROFILES

CUT SLOPES ONLY SHOWN FOR CLARITY

MANDATORY STORED SECTION SETS (G AND B USED)

NOTE ALTERNATIVE SLOPES IN SECTION SET G

INTERFAC, GROUNDMODEL, NEWWORKMODEL

260, MAST, 2=IC18, 4=1, 5=10, 8=100

261, 1=B, 2=VERR, 3=IS18, 5=2, 7=2

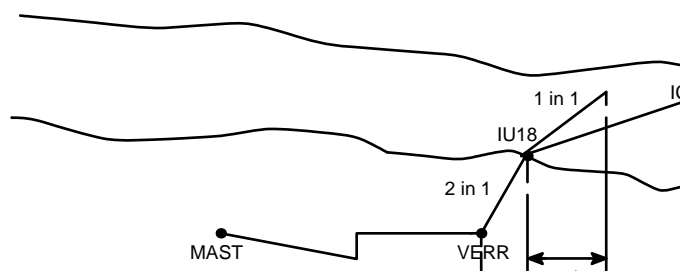
261, 3=IT18, 4=3, 5=4, 7=0

261, 7=1.5

261, 1=G, 2=IU18, 5=1, 7=1

261, 2=IU18, 7=0.3

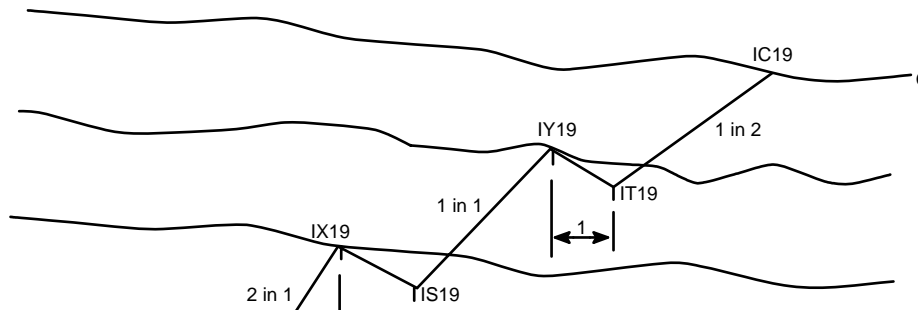
263



**Figure 8 - 110 Example 15 Multi-strata interfaces multi-element profiles special case**

**Example 16 Multi-strata, multi-elements, cutback condition**

- This shows how INTERFACE may be used to project a cut profile to a change of stratum, cut the slope back into the lower stratum and then project a profile to the next higher change of stratum.
- Note the use of a fourth character with IGN to signify that the element is only to be included if an interface is found in the preceding stratum. For example the cutback from IX19 to IS19 is only applicable when VERR is below the C sections.
- This has several practical applications which are more readily appreciated when the cut back portion is considered as a more complex profile than the single element shown. The cut back portion could represent a rock trap in areas of friable rock, a cut off ditch in areas where flash flooding has to be considered, or simply a bench.



**Figure 8 - 111 Example 16 Multi-strata, multi-elements cutback condition**

```

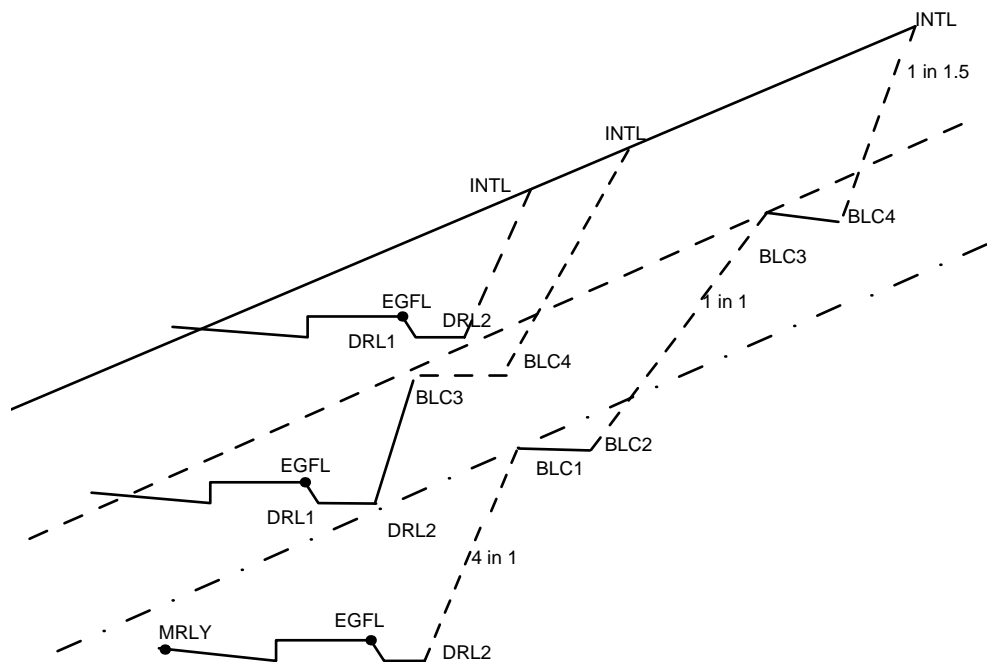
EXAMPLE 16 - MULTI STRATA MULTI-ELEMENTS CUTBACK
CONDITION
CUT SLOPES ONLY SHOWN FOR CLARITY
MANDATORY STORED SECTION SETS (G, B, C) USED
INTERFAC, GROUNDMODEL, NEWWORKMODEL
260, 1=MAST, 2=IC19, 4=1, 5=10, 8=100
261, 1=C, 2=VERR, 7=2
261, IGNC, 2=IX19, 3=IS19, 5=1.5, 7=-0.25
261, B, 7=1
261, IGNB, 2=IY19, 3=IT19, 5=1.0, 7=-0.25
261, 1=G, 7=0.5
263
    
```

**Example 17 Complex multi-strata interfacing**

This example is a practical case from railway engineering which shows how various elements of a profile may be included only in a particular stratum. This has two significant points. Firstly in the ground model a stratum may taper away to nothing in a particular area. Secondly the levels may mean that the profile ‘misses’ a stratum and corrective action as described for example 16 is taken. The 261 option element sequence is automatically updated when named strata do not exist, with the appropriate IGN records being omitted and the level datum updated.

In this case (and only the cut profile (261 records) on one side are described for brevity) the elements EFGL-DRL1 and DRL1-DRL2 are constrained to be present in all strata by use of the IGN indicator. The element in section H is DRL2-BLC1. The bench BLC1-BLC2 only exists if stratum H is present. Likewise the bench BLC3 BLC4 only exists if stratum S is present. This is demonstrated by Figure 8 - 112 and the data shown below.

Whilst there is nothing different from any of the other examples this case does show the sophistication of the INTERFACE option for dealing with complex earthworks.



**Figure 8 - 112 Complex Multi-strata interfacing**

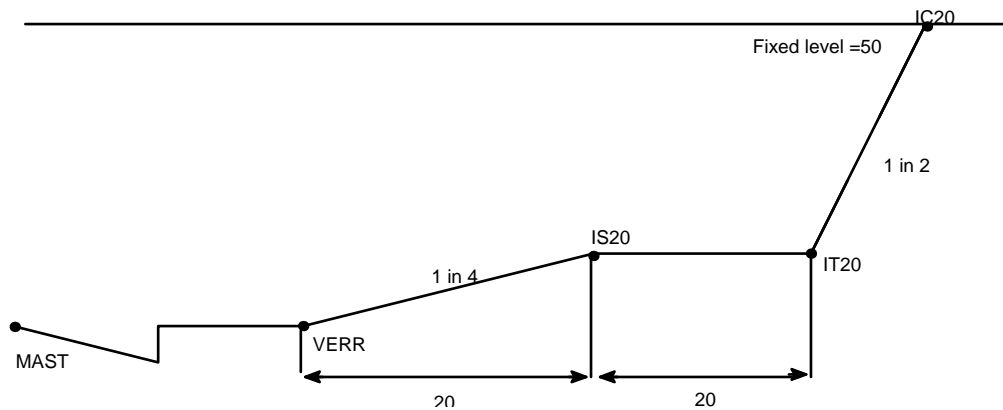


```
EXAMPLE 17 COMPLEX MULTI-STRATA INTERFACING  
CUT SLOPE ONLY SHOWN FOR CLARITY  
MANDATORY STORED SECTIONS X, S, H  
INTERFAC, GROUNDMODEL, NEWWORKMODEL  
260, MRLY, 2=INTL, 4=1, 5=10, 8=100  
261, IGN, EGFL, DRL1, 5=0.45, 7=-1  
261, IGN, DRL1, DRL2, 4=3, 5=0.6, 7=0  
261, H, 7=4  
261, IGNH, BLC1, BLC2, 4=3, 5=3.0, 7=0  
261, S, 7=1  
261, IGNS, BLC3, BLC4, 4=3, 5=3.0, 7=0  
261, X, 7=0.66  
263
```

**Example 18 Interface to a fixed level**

This example shows how INTERFACE may be used to create an interface string at a specified level. A practical application of this technique would be to locate one side of a horizontal berm ie string IC20, then use another INTERFACE data set (with IC20 as the level datum string) to complete the slope profile to the ground.

- ◇ *GROUNDMODEL is specified as the first model, even though it is not used.*
- ◇ *The level into which the slope interfaces is specified in the first minor option 261 field 9.*
- ◇ *The fill slope of -0.5 ie 1 in 2, is not drawn for clarity.*



**Figure 8 - 113 Example 18 Interface to a fixed level**

```

EXAMPLE 18 INTERFACE TO A FIXED LEVEL
INTERFACING TO A FIXED LEVEL
INTERFAC, GROUNDMODEL, NEWWORKMODEL
260, MAST, IC20, 4=1, 5=10, 8=100
261, LEVL, VERR, IS20, 5=20.0, 7=0.25, 9=50
261, 3=IT20, 4=3, 5=20.0, 7=0.005
261, 7=0.5
262, 2=VERR, 7=-0.5
263
    
```

**Example 19 Repeat patterns**

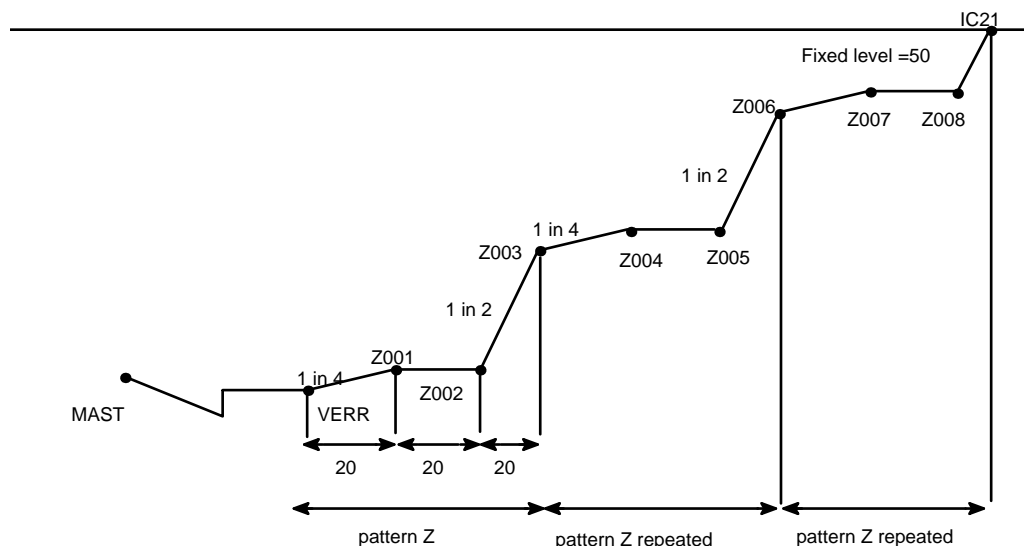
In this example, a repeat pattern extending to a fixed level is specified. Alternatively the repeat pattern may extend to the ground model or a stored section set.

With repeat patterns more than one string may be created. The created strings are automatically labelled from the initial character specified in field 3 (Z in this case).

The number of elements which make up the repeat pattern is specified in field 8 of the first element definition. In this example the first 261 option has '8=3', showing that the current and the next two lines make up the repeat pattern.

The repeat pattern will continue to generate points on the profile until either the interface is found or the limit of profile points on the profile is reached. (Limit of profile points is specified in minor option 260 field 7).

◇ *The fill slope of -0.5, ie 1 in 2, is not drawn for clarity.*



**Figure 8 - 114 Example 19 Repeat patterns**

```

EXAMPLE 19 - REPEAT PATTERN OF 3 TO SINGLE
STRATUM, FIXED LEVEL
INTERFAC, GROUNDMODEL, NEWWORKMODEL
260, MAST, IC21, 4=1, 5=10, 8=100
261, LEVL, VERR, Z, 5=20.0, 7=0.25, 8=3, 9=50
261, 4=3, 5=20.0, 7=0.005
261, 5=20.0, 7=0.5
262, 2=VERR, 7=-0.5
263
    
```

**Example 20 Repeat patterns**

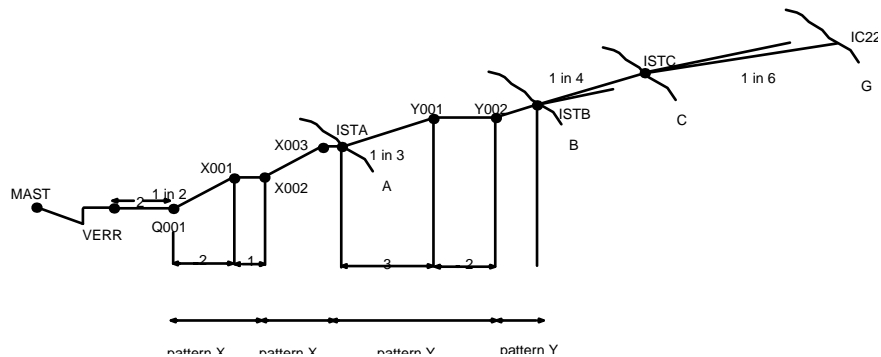
This example shows the use of repeat patterns and alternative slopes with multi strata analysis.

After string Q001 has been created, a slope/berm pattern is specified to interface with stratum A. The interface string label at stratum A has not been given but is assumed to be the next level datum string specified (string ISTA in this case).

Likewise, the next repeat pattern to stratum B creates the interface with the label ISTB.

The alternative slopes specified in strata C and G are similar to example 5.

◇ *Stored sections are required when doing multi strata analysis.*



**Figure 8 - 115 Example repeat patterns**

EXAMPLE 20 REPEAT PATTERNS IN MULTI-STRATA INTERFAC, SECTION MODEL, NEWWORKMODEL standard 260 record, but note field 7  
260,MAST,IC22,,1,7=35

standard 261 record, level datum to Q001  
261,A,VERR,Q001,5=2.5,7=0.0

repeat pattern - character 'X' - from string 'Q001' to stratum 'A'  
261,2=Q001,3=X,5=2,7=0.5,8=2  
261,4=3,5=1,7=0.0

repeat pattern - character 'Y' - from stratum 'A' to stratum 'B'  
261,B,ISTA,Y,5=3,7=0.333,8=2  
261,4=3,5=2,7=0.0

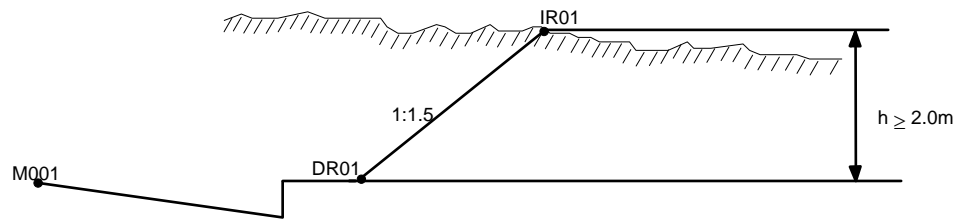
alternative slopes from stratum 'B' to stratum 'C'  
261,C,ISTB,5=5.0,7=0.2  
261,,ISTB,7=0.25

```
alternative slopes from stratum 'C' to  
stratum 'G'  
261,G,ISTC,5=15.0,7=0.2  
261,,ISTC,7=0.1666  
263
```

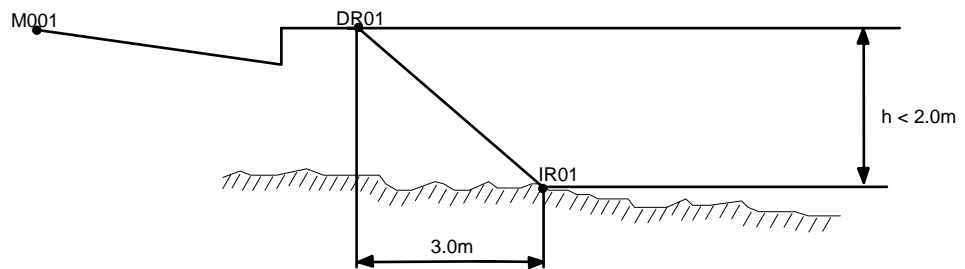
**Example 21 Simple interface with no rounding - German standards**

This example shows the effect of applying German standards to INTERFACE. Both the cut and the fill situations are shown. To show a wider range of circumstances, the cut case is shown for 'h' ≥ 2m and the fill case for 'h' < 2m.

- ◇ German standards are invoked by setting field 10 = 1 in the 260 record.
- ◇ All default German rules are used as fields 7 and 10 in the 261 and 262 records have not been coded. Refer to the section 'German design standards' at the end of this chapter for details of the defaults used.



**Figure 8 - 116 Simple interface - no rounding (cut)**



**Figure 8 - 117 Simple interface - no rounding (fill)**

```

EXAMPLE 21 - SIMPLE INTERFACE TO GERMAN STANDARDS
WITH NO ROUNDING
INTERFAC, GROUNDMODEL, NEWWORKMODEL
260,M001,,IR01,10=1
261,AUTO,DR01
262,,DR01
263

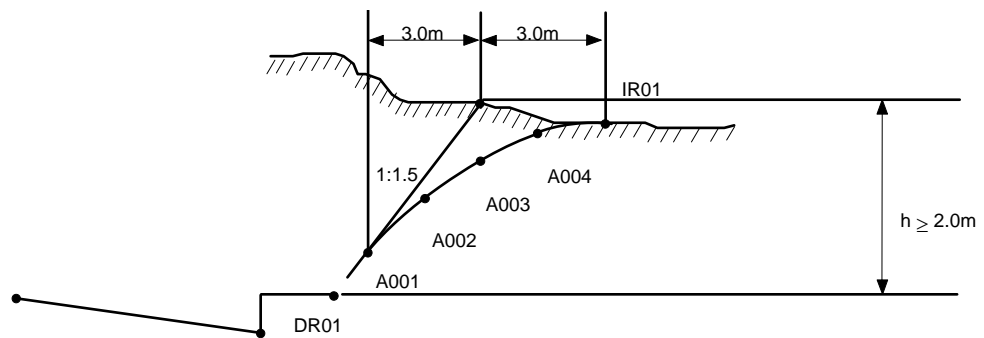
```

**Example 22 Simple interface with rounding - German standards**

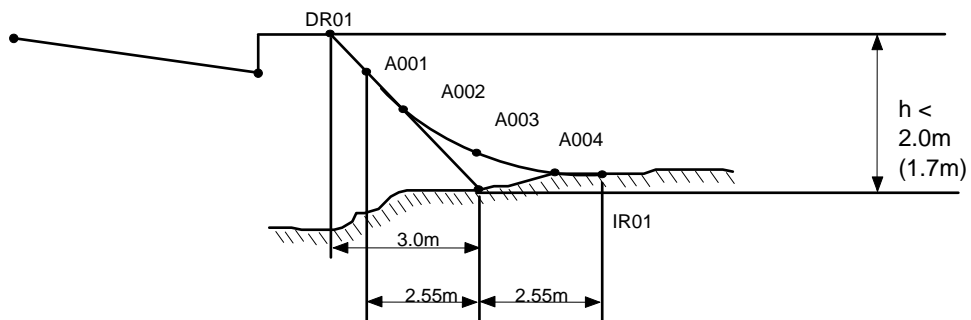
This example shows the effect of applying German standards and rounding to INTERFACE. Both the cut and the fill situations are shown. To show a wider range of circumstances, the cut case is shown for 'h' ≥ 2m and the fill case for 'h' < 2m.

Five strings are created on the parabola used for rounding. The first four are labelled A001, A002 etc and the final string is labelled IR01 (as specified in the 260 record).

- ◇ German standards are invoked by setting field 10 = 1 in the 260 record.
- ◇ All default German rules are used as fields 7 and 10 in the 261 and 262 records have not been coded. Refer to the section 'German design standards' at the end of this chapter for details of the defaults used.
- ◇ Rounding is invoked by the 264 record.



**Figure 8 - 118 Simple interface - with rounding (cut)**



**Figure 8 - 119 Simple interface - with rounding (fill)**

```

EXAMPLE 22 - SIMPLE INTERFACE TO GERMAN STANDARDS
WITH ROUNDING
INTERFAC, GROUNDMODEL, NEWWORKMODEL
260, M001, , IR01, 10=1
261, AUTO, DR01
262, , DR01
    
```

264, 3=A, 8=4

263



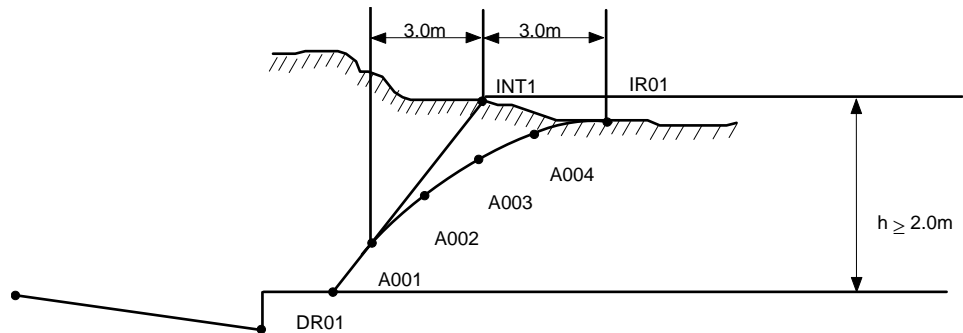
**Example 23 Stored simple interface with rounding - German standards**

This example shows the effect of applying German standards and rounding to INTERFACE. Both the cut and the fill situations are shown. To show a wider range of circumstances, the cut case is shown for 'h' ≥ 2m and the fill case for 'h' < 2m.

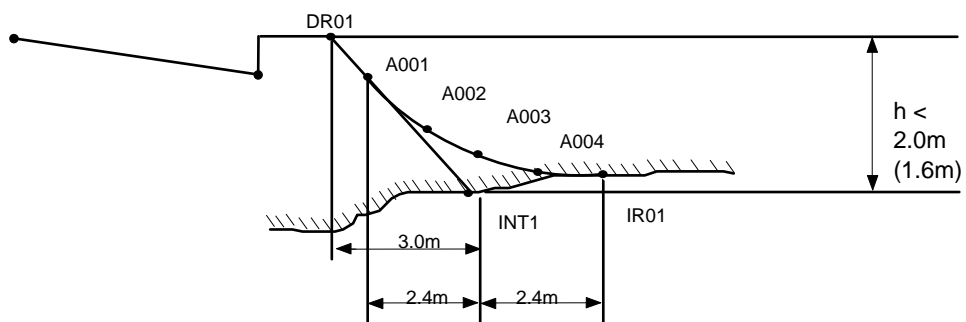
Five strings are created on the parabola used for rounding. The first four are labelled A001, A002 etc and the final string is labelled IR01 (as specified in the 260 record).

The conventional interface string is stored in NEWWORKMODEL as INT1.

- ◇ German standards are invoked by setting field 10 = 1 in the 260 record.
- ◇ All default German rules are used as fields 7 and 10 in the 261 and 262 records have not been coded. Refer to the section 'German design standards' at the end of this chapter for details of the defaults used.
- ◇ Rounding is invoked by the 264 record.



**Figure 8 - 120 Stored simple interface - with rounding (cut)**



**Figure 8 - 121 Stored simple interface - with rounding (fill)**

```

EXAMPLE 23 - SIMPLE INTERFACE TO GERMAN STANDARDS
WITH ROUNDING. STORE CONVENTIONAL INTERFACE STRING
INTERFAC, GROUNDMODEL, NEWWORKMODEL
260,M001,,IR01,10=1
261,AUTO,DR01,INT1
262,,DR01,INT1
    
```



## CHAPTER 8 MAJOR OPTION INTERFACE

---

264, 3=A, 8=4

263

**Example 24 Interface with non-uniform rounding - German standards**

This example assumes that a simple rounding case gives an unacceptable parabola over a 50m section of embankment/cutting. To rectify this, the tangent length is modified over the 50m section to give a smaller parabola.

- ◇ *German standards are invoked by setting field 10 = 1 in the 260 record.*
- ◇ *All default German rules are used as fields 7 and 10 in the 261 and 262 records have not been coded. Refer to the section 'German design standards' at the end of this chapter for details of the defaults used.*
- ◇ *Rounding is invoked by the 264 record.*

EXAMPLE 24 - INTERFACE TO GERMAN STANDARDS WITH  
NON UNIFORM ROUNDING  
INTERFAC, GROUNDMODEL, NEWWORKMODEL

Use default tangent length across range  
260,M001,,IR01,8=100,10=1  
261,AUTO,DR01  
262,,DR01  
264,3=A,8=4  
263

Default tangent length at start of range,  
1.5m at end of range  
260,M001,,IR01,5=100,8=150,10=1  
261,AUTO,DR01  
262,,DR01  
264,3=A,6=1.5,8=4  
263

1.5m tangent length across range  
260,M001,,IR01,5=150,8=200,10=1  
261,AUTO,DR01  
262,,DR01  
264,3=A,5=1.5,6=1.5,8=4  
263

1.5m tangent length at start of range,  
default at end of range  
260,M001,,IR01,5=200,8=250,10=1  
261,AUTO,DR01  
262,,DR01  
264,3=A,5=1.5,8=4  
263

Default tangent length across range  
260,M001,,IR01,5=250,10=1  
261,AUTO,DR01



## CHAPTER 8 MAJOR OPTION INTERFACE

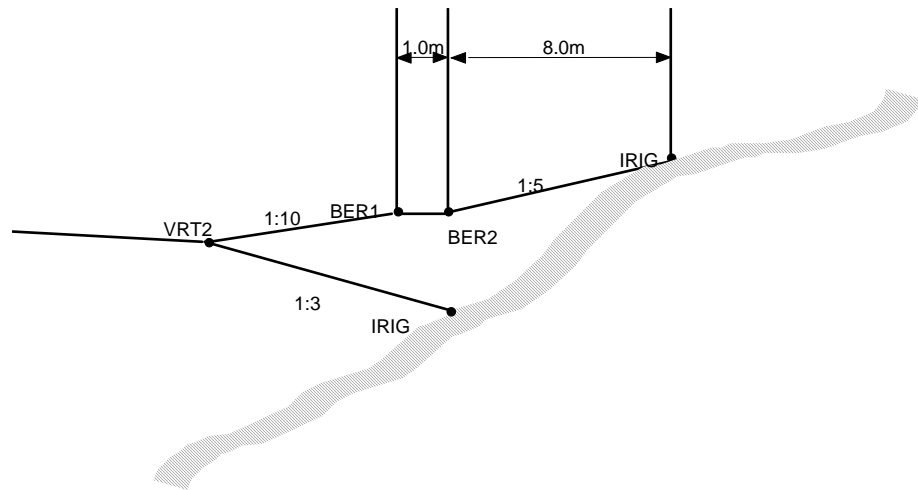
---

262 , , DR01  
264 , 3=A, 8=4  
263

**Example 25 Interface with cut/fill comparison**

This example generates an interface to the right of the reference string MAST using forward cut and reverse fill. Where both the cut and fill cases are equally valid, the interface with the shorter offset from the level datum string is used.

```
EXAMPLE 25 - COMPARISON OF CUT AND FILL INTERFACES  
INTERFAC, GROUNDMODEL, NEWWORKMODEL  
260, MAST, , IRIG, 921, 6=43, 9=87  
261, G, VRT2, BER1, 7=0.1  
261, , BER1, BER2, 4=3, 1, 7=0  
261, , BER2, 7=0.2  
262, , VRT2, 7=-0.333  
263
```



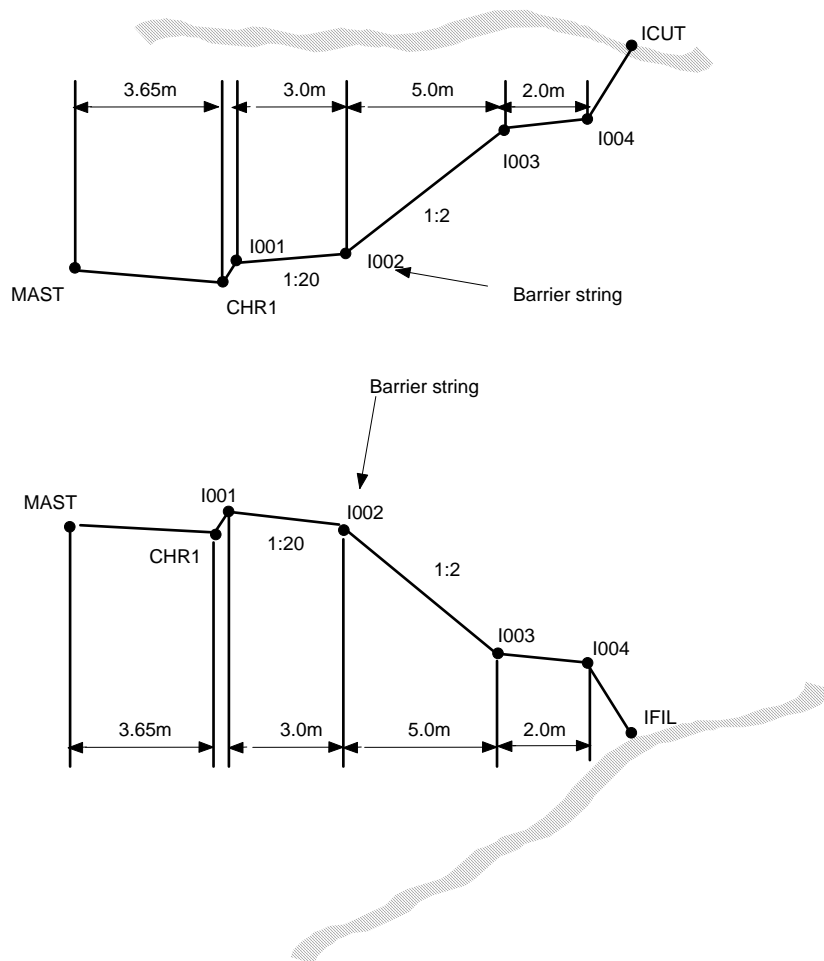
**Figure 8 - 122 Interface with cut/fill comparison**

**Example 26 Interface with barrier string**

This example generates an interface to the right of the reference string MAST using forward analysis. The interface is prevented from reaching the level datum string CHR1 by the barrier string I002.

```

EXAMPLE 26 - INTERFACE WITH BARRIER STRING
INTERFAC, GROUNDMODEL, NEWWORKMODEL
260, MAST, ICUT, IFIL, 1
261, IGN, CHR1, I001, 3, 0.125, , 1.0
261, BARR, , I002, , 3.000, 7=0.05
261, IGN, , I003, 5=5.000, 7=0.5
261, IGN, , I004, 5=2.000, 7=0.01
261, AUTO, 7=0.5
262, IGN, CHR1, I001, 3, 0.125, , 1.0
262, BARR, , I002, 5=3.000, 7=-0.05
262, IGN, , I003, 5=5.000, 7=-0.5
262, IGN, , I004, 5=2.000, 7=-0.01
262, AUTO, , 7=-0.5
263
    
```

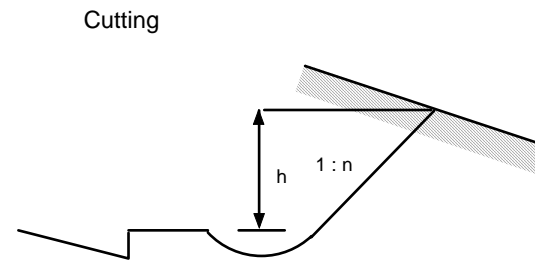
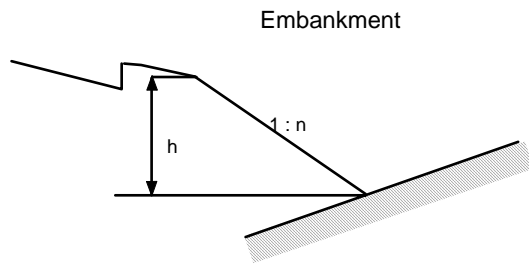


**Figure 8 - 123 Interface with barrier string**

## Design standards for rounded/standard slopes

### German design standards

Slope height  $h \geq 2.0\text{m}$

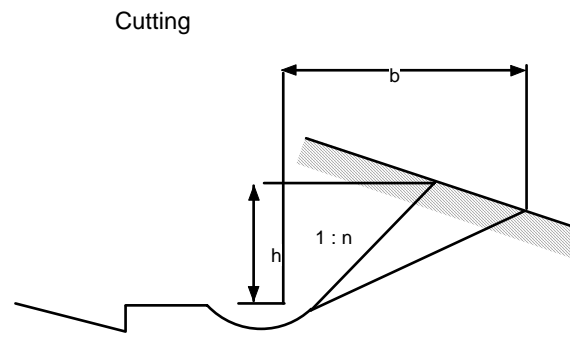
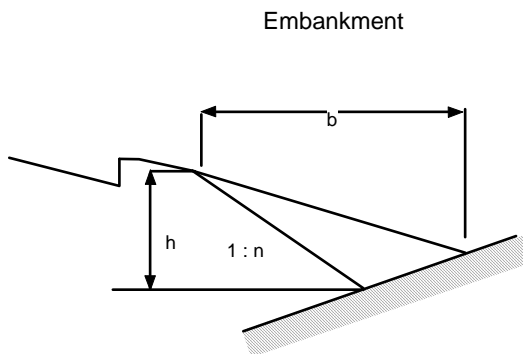


Default values:

*Slope gradient* 1 : 1.5

*Tangent length* 3.0m  
*at rounding*

Slope height  $h < 2.0\text{m}$



Default values:

*Slope width (b)* 3.0m

*Tangent length*  $1.5 \cdot h$   
*at rounding*

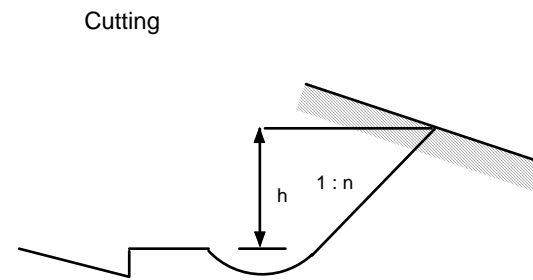
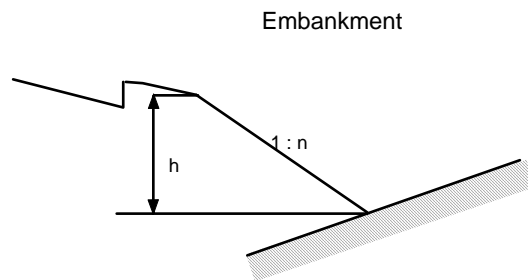
Figure 8 - 124 Rounded/standard slope: German design standards

## User defined

The critical height ( $h_c$ ) is the height below which the slope is changed to accommodate the calculated tangent length. It is given by the formula:

Critical height ( $h_c$ ) = Slope gradient \* tangent length.

Slope height  $h \geq h_c$

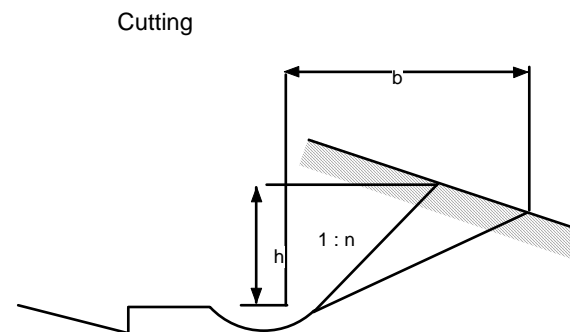
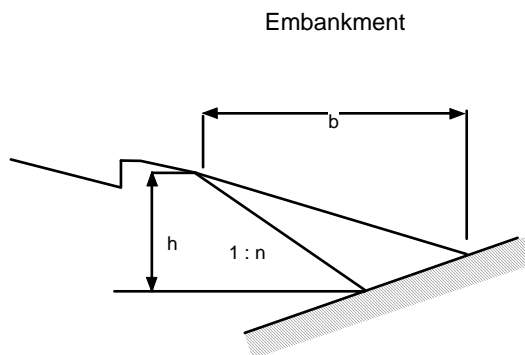


User defined values:

*Slope gradient* as specified, or default in parameter file.

*Tangent length at rounding* as specified, or default in parameter file.

Slope height  $h < h_c$



User defined values:

*Slope width (b)* tangent length as specified, or default in parameter file

*Tangent length at rounding*  $\frac{\text{slope\_height (h)}}{\text{slope gradient}}$

**Figure 8 - 125 Rounded/standard slope: user defined**



# Chapter 9 Analysis by Section

## Extraction of sections through models

MOSS provides a variety of options for the determination of sections through models. These may be long sections taken along a string or sets of cross sections taken at right angles to a string. The sections, particularly cross sections play an important role in many of the MOSS major options including those dealing with the calculation of volumes and the design of interfaces and an understanding of the methods used in extracting sections is extremely important.

The extraction of sections is invoked in one of two ways, either directly using major option SECTION in which case the sections will be stored permanently on the model file for subsequent use or indirectly by other major options which use sections as the basis for performing calculations. Where sections only exist for the duration of a major option and are lost once the operation is complete, they are referred to as 'automatic sections'.

As an aid to efficiency, those major options which use sections as the basis for calculation have been designed to operate in two ways, either using stored sections created previously or by extracting the sections automatically. The major options VOLUME, INTERFACE fall into this category.

The advantage of using stored sections is one of economy in that the sections, once stored, can be used repeatedly for the determination of interfaces, volumes, perspectives, contour models and section drawings.

The following table shows the relationship between the major and minor options and the temporary and permanent storage of sections.

Major option	Minor option	Calculation process	Section type	End product
SECTION	170 - 174	Extraction of section information from model data.	Permanent	Stored section strings on model file.
	175 - 176	Report visibility distance	-	Visibility string
	177 - 178	Extraction of sectional information for triangulation model data.	Permanent	Stored section strings on model file.
GENIO	082	Input of Section Information	Permanent	Stored section strings on model file.
GENIO	083	Output of Section	-	Stored section strings written

		Information		to external file.
INTERFACE	260 - 263	Derivation of Interface between surfaces	Temporary or Permanent	Interface string
VOLUME	050 - 053 058	Volume calculations	Temporary	Volume information and volume string (058)
VOLUME	050 - 056 058	Volume Calculations	Permanent	Volume information and volume string (058)
DRAW	800 - 899	Draw long and cross sections.	Permanent	Graphics drawings

Although the MOSS design procedures require ground surfaces to be stored as models, a facility has been provided within major option GENIO (minor option 082) to permit the storage of ground cross sections recorded in the field as a series of points offset from a line with associated levels. This data is related to the specified master alignment and stored in identical form to the cross sections extracted from a surface model by the system. This feature is particularly useful for processing ground information from manually designed schemes.

The GENIO option also permits the transfer of stored sections to an external file (minor option 083) for use with other programs.

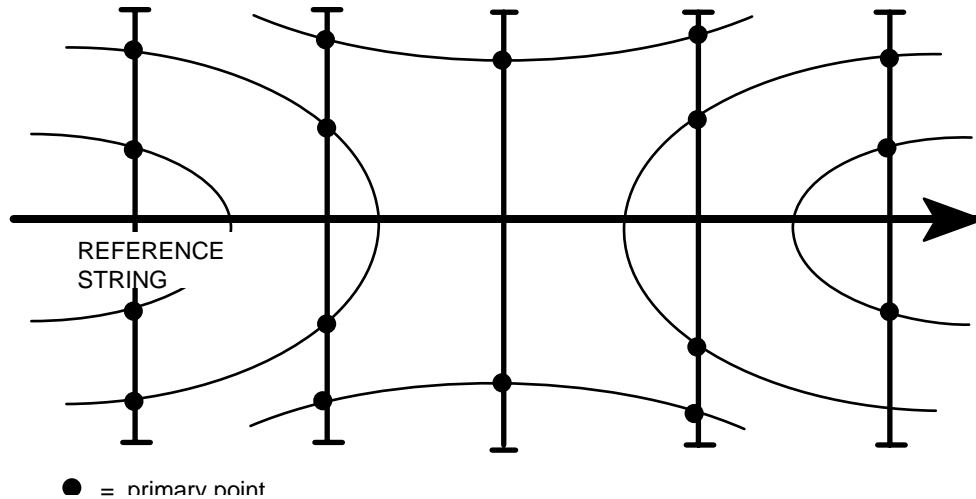
### **Cross section extraction**

Sections may be taken across any model whether it is a series of discrete strings such as a pipe network or a contour and feature string model representing a continuous surface.

The initial process is to determine the intersection points of the section with the strings in the model. This is known as the primary analysis and produces a section string containing these primary intersection points. For continuous surface models this process may provide insufficient points and may be inadequate in certain situations. Therefore, it is also possible to interpolate laterally at intermediate points along the primary section to improve the section definition and this is known as secondary interpolation.

### **Primary interpolation**

The initial sectioning process determines where the defined sections cut the strings within the model.



**Figure 9 - 1 Example – primary interpolation**

The primary points for each section are sorted and stored in left to right order relative to the reference string. The levels of the primary points are linearly interpolated from the links of the string cut.

A primary point is reported as -

Point	X	Y	Z	Offset	Label	Cut
1	501432.433	111172.482	49.923	-22.828	D004	

### Secondary interpolation

Secondary interpolation is invoked by the user and will take place -

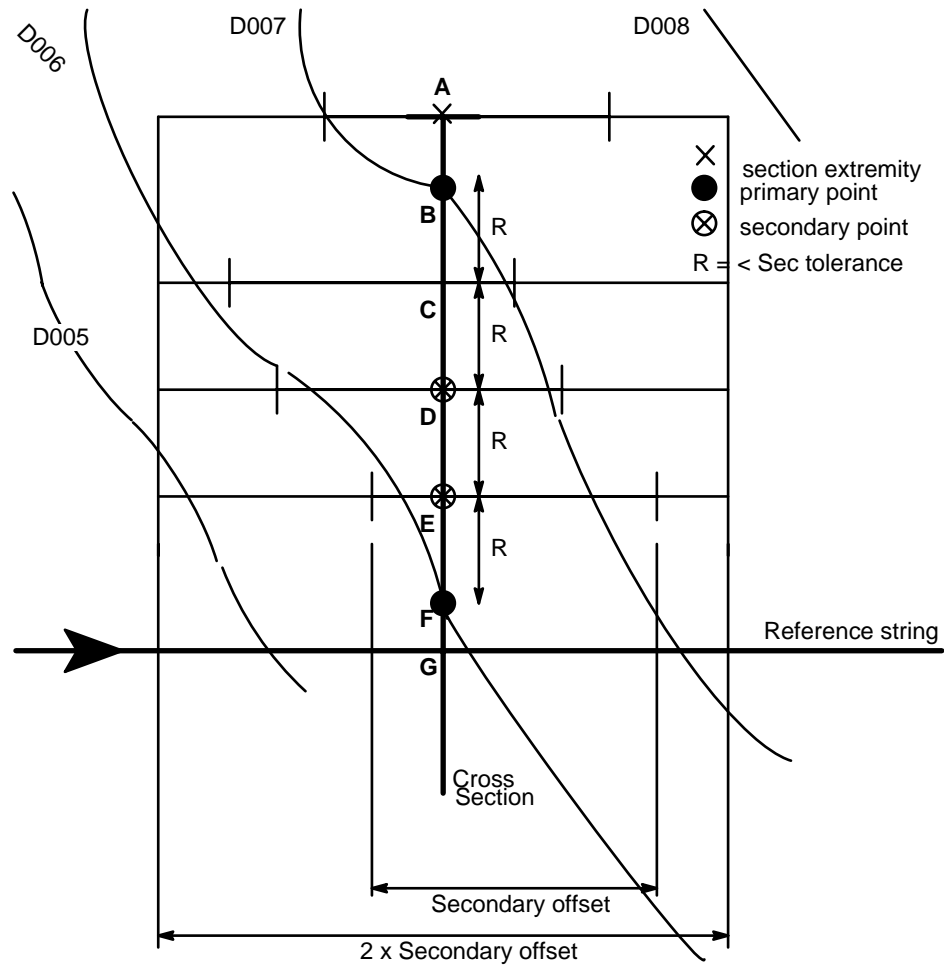
- when the distance between primary points is greater than the secondary interpolation tolerance as defined in minor option 017 field 4.
- at the section extremities.
- when adjacent primary points have identical levels.

The method of secondary interpolation is outlined below -

- the distance between an adjacent pair of primary points, or between a primary point and an extremity, is halved again and again until the distance between the possible secondary points is less than the user defined tolerance.
- at each possible secondary point another section is erected at right angles to the first. The offsets either side are known as the secondary interpolation offsets and are defined by minor option 017 field 9.
- the system searches for two strings, one either side of the primary section, cutting the secondary section. If the distance between these two strings is less than the secondary interpolation offset then a level will be interpolated on the primary section at the secondary point.

A secondary point uses the notation 'TR', which is an abbreviation of Transversely interpolated point. It is reported as:

Point	X	Y	Z	Offset	Label	Cut
1	501432.433	111172.482	49.923	-22.828	*TR*	



**Figure 9 - 2 Example - Secondary interpolation**

In the example shown in Figure 9 - 2 the following should be noted -

- ◇ *points B and F are primary points*
- ◇ *the distance between B and F is greater than the defined secondary tolerance and has therefore been halved and halved again until the distance R is less than the tolerance.*
- ◇ *points A and C failed to find the necessary cuts within the required band width and therefore will not have levels interpolated.*
- ◇ *points D and E are secondary points their levels are determined by interpolation from intersections with D006 and D007.*
- ◇ *the report for the section would be as follows -*

Point	X	Y	Z	Offset	Label	Cut
1 (B)	501426.263	111189.261	53.332	-15.373	D007	
2 (D)	501427.361	11186.274	51.846	-8.132	*TR*	
3 (E)	501429.860	11179.478	50.793	-6.320	*TR*	
4 (F)	501432.433	111172.482	49.923	-2.968	D006	

The restriction on the extent of search is governed by the secondary tolerance and offsets and is intended to produce only local improvement. It can not be stressed too highly that the model content should be sufficient to ensure secondary interpolation is unnecessary excepting the following special cases.

### Transverse curvature

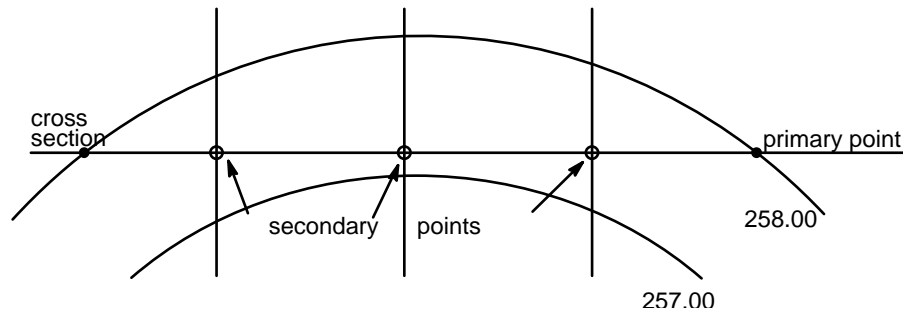


Figure 9 - 3 Example – transverse curvature

This is a common situation where the primary process fails to detect transverse curvature. Whenever adjacent primary points have the same level the secondary process attempts to determine at least one intermediate value, even if the distance between primary points is less than the tolerance.

### Section parallel to strings

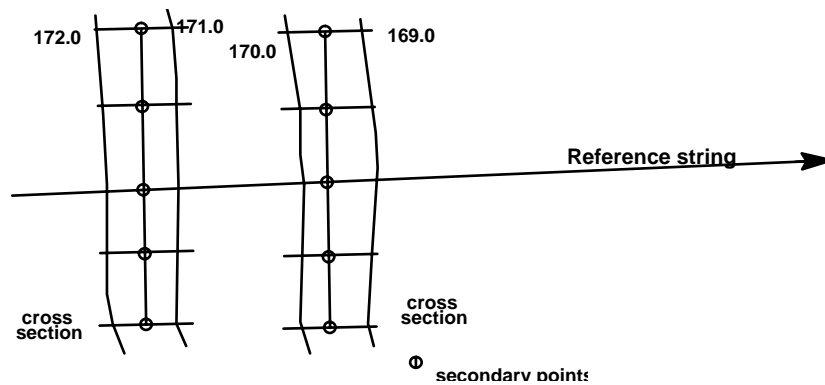
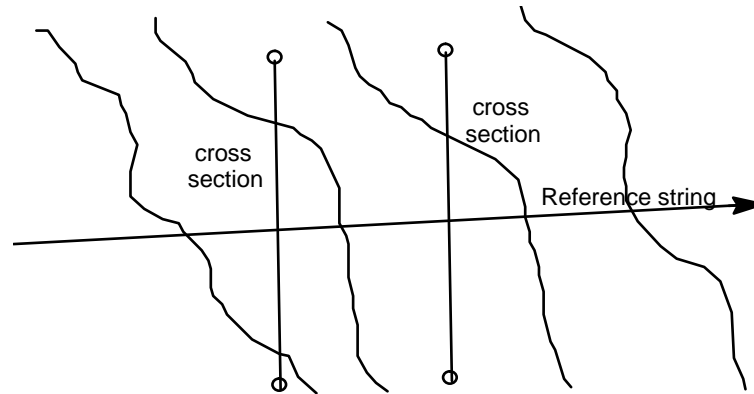


Figure 9 - 4 Example – Section parallel to strings

Occasionally the primary direction for the section is parallel to the string detail. This situation may also be resolved by secondary interpolation whereby the complete section length goes through the secondary process to attempt to put levels onto the section.

Section extremities



**Figure 9 - 5 Example – Section extremities**

Sections are requested to be a certain width and secondary interpolation is used to determine the level of the points at the extremities.

The techniques of primary and secondary interpolation apply to the extraction of both cross sections and long sections. It should be noted that for long sections each string link on the reference string is considered as an individual section and the levels for the section string points at the end of these links are determined by secondary interpolation as described for section extremities.

It will be obvious that to guarantee a complete section from a model both primary and secondary interpolation are required. Each method of interpolation requires complete processing of the stored model and because in many instances primary interpolation is sufficient the secondary process is requested by the user within the option. It is suggested that only detailed and final designs require highly accurate sections and in preliminary design the extra processing overhead may not be warranted. Research has been completed proving that as long as a surface is adequately defined by strings then the described method of extracting sections is very accurate and reliable.

**Tolerances**

The tolerance specified for the secondary interpolation defines the maximum distance required between adjacent points and limits the extent of the search for additional points. The default tolerance is 20.0 units which is the value in metres recommended for detailed highway design at 1/500 scale. At 1/2500 scale the tolerance should be set to 50.0 metres. These values are recommended having consideration of the details of the ground model.

**Masks**

The masking facility is particularly applicable to the extraction of sections because it allows both the unique identification and temporary elimination of

model strings. Using this facility sections may be taken of only the selected content of any model.

### Section points

The determination of the points on sections is a special case of string intersections where the section intersects the straight line links of the surface strings. Curve fitting cannot be invoked in SECTION. When the section cuts are sorted into the final section the adjacent points are compared for having identical offsets (with corresponding X, Y and Z coordinates). This can occur if the section passes through an exact point or if two strings are coincident or cross at that point. The section strings must be inspected for such an occurrence, and the offending points may be removed using EDIT. Up to 1000 points may be stored on each section.

### Stored sections

All sections determined by the options in major option SECTION are stored in a section model, each section being stored as a separate string. These stored sections may be used by major option INTERFACE, VOLUME etc. Options 170, 171 and 177 produce only one section and this is given a label defined by the user. Options 173, 174 and 178 produce a series of sections and each is referenced by a label formed of a unique first character specified by the user, followed by a reference to the point on the string from which the section was generated, ie C307. The sub-reference of the section string contains the label of the string from which the section was generated. Several series of sections may be stored within a section model and each series will have its own unique identification with a different initial character for the string label.

When specifying the section offsets for options 173, 174 and 178 the offsets are given as distances to the left and right relative to the direction of proceeding along the string (which may not be the direction of the stored string).

Section strings are stored as a series of points, each point being defined by its X and Y coordinates, offset from the reference line, level and the cutting string label. To ensure consistency the points on the stored section are always ordered from left to right in the direction of the reference string. Long sections are always stored in the same direction as the reference string: each point is defined by its X and Y coordinates, chainage along the reference string, level and the cutting string label. For 6D strings the chainage is that for the corresponding point on the reference string. For other strings the chainage is the sum of the straight line distances from the start of the reference string.

The stored sections are used by several major options and the detail of their application is fully described in the documentation for the relevant options.

- ◇ *Reference strings are used in the generation of sections. If a reference string is edited after the generation of sections then the sections will be incorrect when drawn. It is therefore necessary to regenerate sections after a reference string has been changed.*

Long sections

The techniques of primary and secondary interpolation, as described with reference to cross sections, also apply to the extraction of long sections. There is also one additional feature which is unique to long sections. Each string link on the reference string is considered as an individual section. Primary points are determined where these links intersect model detail. The levels for the section string points, which form the ends of these links, may be determined by secondary interpolation when invoked. However, if the normal secondary interpolation process fails to find a level then linear interpolation will take place.

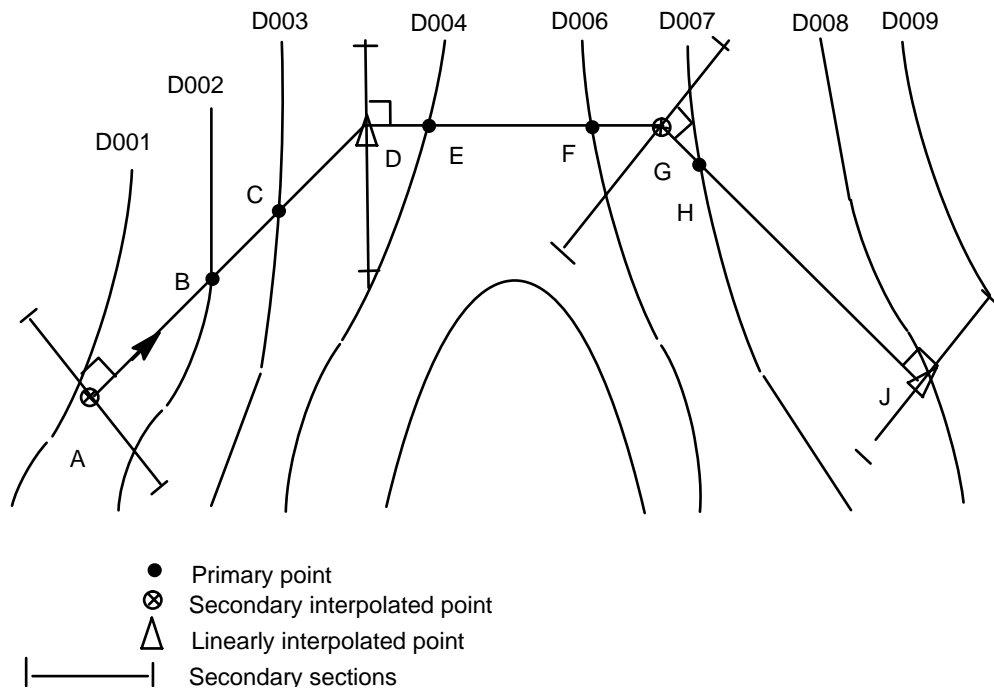


Figure 9 - 6 Example - linear interpolation

In the example in Figure 9 - 6 the following should be noted -

- ◇ *The secondary sections are at right angles to the string link following the considered point except for the last point which uses the preceding link. (The last point is either the very last point on the string or the point defined as the end point on the option).*
- ◇ *Primary points were determined at points B, C, E, F and H.*
- ◇ *Points derived by the normal secondary interpolation process gave levels at points A and G.*
- ◇ *Linear interpolation gave levels at points D and J. the level at D is interpolated from C and E. the level at J is transferred from H.*
- ◇ *The report of the section would be as follows -*

*where 'LN' is an abbreviation of Linearly Interpolated point.*



Point	X	Y	Z	Offset	Label	Cut
1 (A)	501426.263	111189.261	53.332	0.000	*TR*	
2 (B)	501431.769	111193.186	54.000	5.683	D002	
3 (C)	501435.386	111197.313	55.000	8.239	D003	
4 (D)	501442.175	111201.686	55.761	12.635	*LN*	
5 (E)	501446.513	111201.689	56.000	14.012	D004	
6 (F)	501452.890	111201.692	56.000	18.263	D006	
7 (G)	501456.484	111201.695	55.666	20.013	*TR*	
8 (H)	501462.136	111195.201	55.000	23.506	D007	
9 (J)	501475.916	111189.213	55.000	32.686	*LN*	

### Design feature

The long section options (171 and 177) are generally used to extract and store a new long section along the line of an existing string. However, these options have the additional facility of putting levels back onto the original string points only. Secondary interpolation must be invoked to do this.

### Section labelling

Up until Version 8 sections were stored with string labels formed by adding a unique character to the front of the sequence number of the point on which the section is based. For example the section at point 34 on string MASR would be stored as SO34 if the initial character had been given as S. This sequencing technique imposes a restriction of 999 onto the number of possible sections.

From Version 8 the algorithm has been changed to follow the standard labelling convention adopted throughout MOSS. Consequently strings are labelled 0-9, A-Z before incrementing the next character.

All options which access section strings use the labelling convention described.

◇ *Models containing section strings created previously to version v8 must be updated using minor option 020 in EDIT.*

### Visibility

SECTION minor option 175 (176) is a facility to calculate and present visibility distances. It is used in conjunction with option 174 which generates a series of cross sections along a reference string. Option 175 (or 176) moves a target away from an eye point and examines the intervening sections to see if the target is still visible. This process of moving the target away from an eye point continues until visibility is lost, or until a user defined 'minimum visibility' is reached. In the case of visibility being lost, an interpolated point is calculated between the target point last seen, and the target that is now out of sight. The distance from eye to target is output and the process moves on to the next eye point. Option 176 allows the eye and target to run in the reverse direction along the master alignment.

## Major option SECTION

Major option SECTION consists of several minor options for the extraction of sections from a model. The options provide for the extraction of cross sections for calculating volumes, profiles along strings and along straight lines. The minor options available are as follows:-

170	Long - between 2 points
171	Long - along a string
173	Cross - relative to a string
174	Cross - relative to a master
175	Visibility along section
176	Visibility against section
177	Long - through triangulation
178	Cross - through triangulation

The procedure to determine the sections involves two stages known as primary and secondary analysis. The primary analysis finds those points of intersection of the section with the strings in the model and these are the primary points defining the feature lines or contours. In the case of continuous surfaces where insufficient strings are cut by the section the system can be requested to search at right angles to the section. If this secondary search detects a 'cut' on either side of the section within a defined tolerance then a level is generated by linear interpolation.

It should be stressed that it is the users responsibility to ensure that sufficient strings exist in the model to produce an accurate model profile.

The major option provides several techniques for extracting sections. Minor option 170 permits the determination of a single profile between two points which is useful for checking visibility. A long section along a string is determined by minor option 171. The primary analysis determines all the cuts with the model strings on the long section. If levels are required at the points on the reference string, secondary interpolation must be requested. Minor option 173 is a general purpose option which extracts sections at right angles to any string. The string is curve fit to determine the direction of the sections. Option 174 is more specific in that the string must be a master alignment as required in highway design, and the sections are determined at a regular chainage interval. Minor options 175 and 176 both use sectioning techniques to determine visibility information. Minor options 177 and 178 provide similar facilities to options 171 and 173 but using the techniques of threading through a triangulation.

The width of the sections for minor option 173 and 174 are specified by left and right offsets to a reference line or string. It is important to note that offsets to the left of the reference line or string must be specified as negative numbers, otherwise if both the left and right offsets are positive numbers the section will be completely to the right of the reference string or line. Note that such a situation may be desirable in certain cases.

All the extracted sections are stored in a defined model with unique labels. The output from the minor options lists only the offset and level of the points on each section. The complete section information may be reported with minor option 994 or 985/986 in REPORT which will interpret the string labels.

### Appended sections

Appended sections are used so that different secondary interpolation tolerances and offsets may be specified between different points along a reference string.

Within a single use of major option SECTION, a set of cross sections can be built up from adjacent subsets taken between specified points on a reference string. This is achieved by calling the appropriate minor option to generate each subset and using SPRD to indicate where the subset starts and ends.

In a similar way, a long section can be constructed from adjacent portions taken between specified points on a reference string.

The following rules apply when generating appended sections:

- The same reference string must be used for generating each subset of cross sections or portion of a long section.
- The start point of a subset or portion must be the same as the end point of the previous subset or portion.
- On exit from major option SECTION, no more subsets or portions can be appended.

## Access to major option SECTION

IGENLT.DAT, GEN002

Analysis options
AREA
TRIANGLE
SECTION
VOLUME
SURFACE
PRISM
EDIT
COPY
REPORT

## Model for SECTION

### Input

#### Graphics

IGSECTT.DAT, SEC001

<b>Model to be Sectioned</b>
Model to be sectioned
Reference model (optional)
<b>Model to contain sections</b>

## Linemode

Major option SECTION

Model 1 Model containing the strings used to determine the sections, or model containing the triangulation to be sectioned (must be a .TRIA type model). This model must also contain the section reference string if no second model is specified.

Model 2 Model containing the section reference string.

Major option SECTION

Model 3 Model for storing the extracted sections.

## Global minor options

The global options 000, 017, 019, 900 and 999 may be used with SECTION.

It is not permissible to use a string containing a discontinuity between the start and end points as a reference string.

**Minor option 017    Define section parameters****Input**

## Graphics

IGSECTT.DAT, SEC002, SEC003

SECTION option details	Define section parameters
Define section parameters	SINT tolerance
Define linear units	SINT offsets
Define string masking	
Long - Between 2 points	
Long - Along a string	
Cross - relative to string	
Cross - relative to master	
Visibility along section	
Visibility against section	
Long - thru triangulation	

## Linemode

**Minor option 017**

Field 4        Secondary interpolation tolerance, default 20.0

Field 9        Secondary interpolation offset, default equal to secondary interpolation tolerance.

The section offset tolerances permitted in fields 7 and 10 of this minor option, do not apply to major option SECTION and are ignored. These offsets are specified with the relevant minor option data.

**Minor option 170    Long - between 2 points**

Determination of a long section along a line defined by a pair of coordinates.

Input

Graphic

IGSECTT.DAT, SEC002, SEC004

SECTION option details	Long - between 2 points
Define section parameters	Label of generated string
Define linear units	Secondary interpolation (T)
Define string masking	Start chainage / X coord
Long - between 2 points	Start point no. / Y coord
Long - along a string	End chainage / X coord
Cross - relative to string	End point no. / Y coord
Cross - relative to master	
Visibility along section	
Visibility against section	
Long - thru triangulation	

Linemode

Minor option 170

Field 2 If secondary interpolation is required specify SINT.

- \* Field 3 A unique four character label for storing the section string.
- \* Field 5 & 6 Coordinates of the start of the section.
- \* Field 8 & 9 Coordinates of the end of the section.

Example

```

MOSS>SECTION,NEW THORNBROUGH
SECTION NEW THORNBROUGH

SECT>SECTION,THORNBROUGH SECTIONS
SECTION THORNBROUGH SECTIONS

SECT>170,3=SEC1,,3110,30350,,3410,30480
170      SEC1          3110    30350          3410    30480

STRING SEC1
-----
NPT  -OFFSET-  -LEVEL-  NPT  -OFFSET-  -LEVEL-  NPT  -OFFSET-  -LEVEL-
  1    64.817  129.665   7    134.798  138.923  13   186.664  137.604
  2    74.891  129.673   8    139.316  138.918  14   195.687  137.164
  3    91.121  137.740   9    147.323  138.915  15   208.034  131.000
  4   100.158  138.180  10    154.377  138.513  16   218.047  131.000
  5   103.170  138.257  11    166.425  138.189
  6   130.279  138.928  12    167.233  138.191

NUMBER OF CUTS =      16
-----

```

Minor option 171 Long - along a string

Determination of a long section along a previously created string.

If secondary interpolation is requested, levels at all points on the string are interpolated either by the secondary process or by linearly interpolating between adjacent points. In this way there will be no lateral differences between the reference string and the string being generated.

It is also possible to attach the extracted levels directly to the reference string so that in effect the option is used as a design function. This facility necessitates requesting secondary interpolation but not specifying the unique 4 character string label for storing the section string. It should be noted that no new points will be added into the string and only the existing points will have levels attached. Note that no printout is given so it is advisable to obtain a report of the resulting string using Report option 992.

Input data

Graphics

IGSECTT.DAT, SEC002, SEC005

SECTION option details	Long - along a string
Define section parameters	Label of generated string
Define linear units	Reference string label
Define string masking	Secondary interpolation
Long - between 2 points	Start chainage / X coord
Long - along a string	Start point no. / Y coord
Cross - relative to string	End chainage / X coord
Cross - relative to master	End point no. / Y coord
Visibility along section	
Visibility against section	
Long - thru triangulation	

Linemode

Minor option 171

- \* Field 1 Reference string.
- Field 2 If secondary interpolation is required specify SINT.
- Field 3 A unique 4 character label for storing the section string. If levels are to be supplied to the reference string leave blank but note that in this instance SINT must be defined in Field 2.
- Field 5 & 6 SPRD start
- Field 8 & 9 SPRD end.

If levels are requested at points corresponding to the reference string, secondary interpolation must be requested.



- ◇ *If field 3 is blank a temporary long section string is created with default label TTTT. If the string already exists in the model the 'string already exists' error message results.*
- ◇ *Drainage strings may be used as the reference string.*

Example 1

A highway master alignment, superimposed upon a ground model of the area, for which points are stored at a regular 20 metre interval. Secondary interpolation is not required to introduce additional points at a smaller interval, but levels are required at each chainage point and the secondary interpolation offset search is defined as 50 metres on the 017 minor option. The output string is stored under the label LSCT.

```

MOSS>SECT,THORNBROUGH GROUND MODEL,NEW THORNBROUGH
SECT THORNBROUGH GROUND SECTIONS NEW THORNBROUGH

SECT>SECT NEW THORNBROUGH SECTIONS
SECT NEW THORNBROUGH SECTIONS

STANDARD DESIGN RULES APPLIED.

SECT>017,9=50
017
50
W120 SYSTEM VALUES HAVE BEEN MODIFIED

VALUES ADOPTED :TOLERANCE 0.0100

LEFT OFFSETS -100.0000
RIGHT OFFSETS 100.0000
SECONDARY TOLERANCE 20.0000
SECONDARY OFFSET 50.0000
REFERENCE ANGLE 0.00000
CURVE FITTING INVOKED
STANDARD CONTENTS 7700
STATIONS STRING PSSA
ANGLE DEFINITION:
INPUT: NORM OUTPUT: NORM
COORDINATE DEFINITION:
INPUT: XY OUTPUT: XY
STANDARD DESIGN RULES APPLIED.

SECT>171,M003,SINT,LSCT,5=3900,8=5700
171M003SINTLSCT 3900 5700

STRING LSCT
-----
NPT -OFFSET- -LEVEL- NPT -OFFSET- -LEVEL- NPT -OFFSET- -LEVEL-

1 3900.000 132.142 51 4512.500 130.283 101 5087.500 122.369
2 3912.500 132.142 52 4525.000 130.202 102 5100.000 122.306
3 3925.000 132.142 53 4537.500 130.121 103 5112.500 122.306
4 3937.500 132.142 54 4550.000 130.039 104 5125.000 122.318
5 3950.000 132.142 55 4556.031 130.000 105 5137.500 122.354
6 3962.500 132.142 56 4575.000 129.739 106 5150.000 122.384
7 3975.000 132.142 57 4587.500 129.567 107 5162.500 122.373
8 3987.500 132.142 58 4600.000 129.395 108 5175.000 122.365
9 4000.000 132.142 59 4612.500 129.223 109 5187.500 122.369
10 4012.500 132.142 60 4625.000 129.051 110 5200.000 122.394
11 4025.000 132.142 61 4628.726 129.000 111 5212.500 122.417

etc

44 4425.000 130.853 94 5000.000 122.710 144 5613.932 122.000
45 4437.500 130.772 95 5012.500 122.675 145 5625.000 122.181
46 4450.000 130.690 96 5025.000 122.642 146 5640.586 122.500
47 4462.500 130.609 97 5037.500 122.611 147 5650.000 122.684
48 4475.000 130.527 98 5050.000 122.558 148 5666.739 123.000
49 4487.500 130.446 99 5060.413 122.500 149 5675.000 123.167
50 4500.000 130.365 100 5075.000 122.426 150 5691.282 123.500

STRING LSCT
-----
NPT -OFFSET- -LEVEL- NPT -OFFSET- -LEVEL- NPT -OFFSET- -LEVEL-

151 5700.000 123.770

NUMBER OF CUTS = 151

-----
SECT>999
MOSS>REPO NEW THORNBROUGH SECTIONS
REPO NEW THORNBROUGH SECTIONS

----- M O D E L N A M E ----- RECORD SECURITY DATE LAST USED -----
NEW THORNBROUGH SECTIONS 4548 FREE 21JAN91

REPO>992LSCT
992LSCT

LABEL SUBREF CONTENTS NO.PTS X -MIN Y -MIN X -MAX Y -MAX RECORD LOC.

```

LSCT	M003	7705	151	3079	29315	3745	30979	4549	1
POINT	-----X-----	-----Y-----	-----Z-----	---OFFSET---	-LABEL CUT-				
1	3079.555	30978.150	132.142	3900.000	*LN*				
2	3082.113	30965.915	132.142	3912.500	*LN*				
3	3084.671	30953.679	132.142	3925.000	*LN*				
4	3087.289	30941.456	132.142	3937.500	*LN*				
5	3089.907	30929.234	132.142	3950.000	*LN*				
6	3092.585	30917.024	132.142	3962.500	*LN*				
7	3095.263	30904.814	132.142	3975.000	*LN*				
8	3098.001	30892.618	132.142	3987.500	*LN*				
9	3100.738	30880.421	132.142	4000.000	*LN*				
10	3103.536	30868.238	132.142	4012.500	*LN*				
11	3106.334	30856.056	132.142	4025.000	*LN*				
12	3109.191	30843.886	132.142	4037.500	*LN*				
13	3112.049	30831.717	132.142	4050.000	*LN*				
14	3114.966	30819.563	132.142	4062.500	*LN*				
15	3117.883	30807.408	132.142	4075.000	*LN*				
16	3120.860	30795.267	132.142	4087.500	*LN*				
17	3123.837	30783.127	132.142	4100.000	*LN*				
18	3126.873	30771.002	132.142	4112.500	*LN*				
19	3129.909	30758.876	132.142	4125.000	*LN*				
20	3133.005	30746.765	132.142	4137.500	*LN*				
21	3136.101	30734.655	132.142	4150.000	*TR*				
22	3139.256	30722.560	132.109	4162.500	*TR*				
23	3142.411	30710.464	132.079	4175.000	*TR*				
24	3145.626	30698.385	132.068	4187.500	*TR*				
25	3148.841	30686.305	132.054	4200.000	*TR*				
26	3153.398	30669.511	132.000	4217.402	0004				
27	3155.388	30662.178	131.959	4225.000	*LN*				
28	3158.721	30650.130	131.891	4237.500	*LN*				
29	3162.054	30638.083	131.824	4250.000	*LN*				
30	3165.446	30626.052	131.756	4262.500	*LN*				
31	3168.839	30614.021	131.689	4275.000	*LN*				
32	3172.290	30602.007	131		*LN*				
33	3175.741	30589							
34	3179								
35									

Example 2a

This example, taken from the example used for the DESIGN minor option 145, illustrates the creation of levels along the string M103. The levels for M103 may be obtained from the ground model with the 171 minor option.

```

MOSS>SECT, THORNBROUGH GROUND MODEL, NEW THORNBROUGH
SECT THORNBROUGH GROUND MODEL NEW THORNBROUGH

SECT>SECT, NEW THORNBROUGH SECTIONS
SECT TEMP

SECT>017, 4=100
017 100

W120 SYSTEM VALUES HAVE BEEN MODIFIED
VALUES ADOPTED :
SEARCH TOLERANCE 0.0100
LEFT OFFSETS -100.0000
RIGHT OFFSETS 100.0000
SECONDARY TOLERANCE 100.0000
SECONDARY OFFSET 100.0000
REFERENCE ANGLE 0.00000
CURVE FITTING INVOKED
STANDARD CONTENTS 7700
STATIONS STRING PSSA
ANGLE DEFINITION:
INPUT: NORM OUTPUT: NORM
COORDINATE DEFINITION:
INPUT: XY OUTPUT: XY
STANDARD DESIGN RULES APPLIED.

SECT>171MI03SINT
171MI03SINT
SECT>999
999

REPO>REPO, NEW THORNBROUGH
REPO NEW THORNBROUGH

----- M O D E L N A M E ----- RECORD SECURITY DATE LAST USED -----
NEW THORNBROUGH 2976 FREE 21JAN91

REPO>992MI03
992MI03

LABEL SUBREF CONTENTS NO.PTS X -MIN Y -MIN X -MAX Y -MAX RECORD LOC.
MI03 7706 38 3628 29685 3640 29719 3049 1

POINT -----X-----Y-----Z-----C-----B-----R-----
1 3628.837 29686.064 122.936 0.968 55 9 33.4 -25.000
2 3628.863 29686.082 122.936 1.000 55 5 13.4 -25.000
3 3629.672 29686.670 122.936 2.000 52 47 42.8 -25.000
4 3630.456 29687.291 122.936 3.000 50 30 12.2 -25.000
5 3631.214 29687.942 122.936 4.000 48 12 41.6 -25.000

```

6	3631.947	29688.623	122.936	5.000	45	55	11.0	-25.000
7	3632.651	29689.333	122.936	6.000	43	37	40.4	-25.000
8	3633.326	29690.070	122.936	7.000	41	20	9.8	-25.000
9	3633.971	29690.834	122.936	8.000	39	2	39.2	-25.000
10	3634.586	29691.623	122.936	9.000	36	45	8.7	-25.000
11	3635.168	29692.436	122.936	10.000	34	27	38.1	-25.000
12	3635.717	29693.272	122.936	11.000	32	10	7.5	-25.000
13	3636.232	29694.129	122.936	12.000	29	52	36.9	-25.000
14	3636.713	29695.006	122.936	13.000	27	35	6.3	-25.000
15	3637.158	29695.901	122.936	14.000	25	17	35.7	-25.000
16	3637.567	29696.813	122.936	15.000	23	0	5.1	-25.000
17	3637.940	29697.741	122.936	16.000	20	42	34.5	-25.000
18	3638.274	29698.684	122.936	17.000	18	25	3.9	-25.000
19	3638.571	29699.638	122.936	18.000	16	7	33.3	-25.000
20	3638.830	29700.604	122.936	19.000	13	50	2.7	-25.000
21	3639.049	29701.580	122.938	20.000	11	32	32.1	-25.000
22	3639.230	29702.563	122.941	21.000	9	15	1.5	-25.000
23	3639.371	29703.553	122.943	22.000	6	57	31.0	-25.000
24	3639.472	29704.548	122.946	23.000	4	40	0.4	-25.000
25	3639.533	29705.546	122.949	24.000	2	22	29.8	-25.000
26	3639.555	29706.546	122.951	25.000	0	4	59.2	-25.000
27	3639.536	29707.546	122.954	26.000	357	47	28.6	-25.000
28	3639.478	29708.544	122.957	27.000	355	29	58.0	-25.000
29	3639.379	29709.539	122.959	28.000	353	12	27.4	-25.000
30	3639.241	29710.529	122.962	29.000	350	54	56.8	-25.000
31	3639.064	29711.513	122.965	30.000	348	37	26.2	-25.000
32	3638.847	29712.489	122.967	31.000	346	19	55.6	-25.000
33	3638.591	29713.456	122.970	32.000	344	2	25.0	-25.000
34	3638.297	29714.412	122.972	33.000	341	44	54.4	-25.000
35	3637.965	29715.355	122.974	34.000	339	27	23.8	-25.000
36	3637.596	29716.284	122.976	35.000	337	9	53.3	-25.000
37	3637.189	29717.198	122.978	36.000	334	52	22.7	-25.000
38	3637.110	29717.365	122.978	36.185	334	26	57.1	-25.000

Example 2b

A centre line of carriageway string, CCL1 is created with design minor option 100. To illustrate the use of the 171 minor option the levels for CCL1 are obtained by sectioning between the adjacent detail strings. This technique is suitable for determining the levels on detail strings defining traffic islands etc.

```

MOSS>DESIGN,NEW THORNBROUGH
DESIGN NEW THORNBROUGH
DESI>100,M003,,CCL1,5=3900,, -19.5,5700
100M003 CCL1 3900 -19.5 5700
DESI>999
999

MOSS>SECT,NEW THORNBROUGH
SECT NEW THORNBROUGH
SECT>SECT,NEW THORNBROUGH
SECT NEW THORNBROUGH
SECT>017,4=100
017 100

W120 SYSTEM VALUES HAVE BEEN MODIFIED
VALUES ADOPTED :
SEARCH TOLERANCE 0.0100
LEFT OFFSETS -100.0000
RIGHT OFFSETS 100.0000
SECONDARY TOLERANCE 100.0000
SECONDARY OFFSET 100.0000
REFERENCE ANGLE 0.00000
CURVE FITTING INVOKED
STANDARD CONTENTS 7700
STATIONS STRING PSSA
ANGLE DEFINITION:
INPUT: NORM OUTPUT: NORM
COORDINATE DEFINITION:
INPUT: XY OUTPUT: XY
STANDARD DESIGN RULES APPLIED.

SECT>019,EI01,4=1
019EI01 1
SECT>019,OC01,4=1
019OC01 1
SECT>019,4=-1
019 -1
SECT>171,CCL1,SINT
171CCL1SINT
SECT>999
999

MOSS>REPORT,NEW THORNBROUGH
REPORT NEW THORNBROUGH

----- M O D E L N A M E ----- RECORD SECURITY DATE LAST USED -----
NEW THORNBROUGH 2976 FREE 21JAN91

REPO>992CCL1
992CCL1
LABEL SUBREF CONTENTS NO.PTS X -MIN Y -MIN X -MAX Y -MAX RECORD LOC.
CCL1 7703 73 3098 29325 3761 30983 4556 1
POINT -----X-----Y-----Z-----
1 3098.652 30982.094 132.835

```

2	3103.748	30957.716	132.835
3	3108.964	30933.365	132.984
4	3114.300	30909.039	133.144
5	3119.754	30884.739	133.313
6	3125.328	30860.467	133.493
7	3131.021	30836.222	133.684
8	3136.833	30812.005	133.885
9	3142.764	30787.817	134.096
10	3148.814	30763.659	134.318
11	3154.982	30739.531	134.550
12	3161.268	30715.433	134.793
13	3167.672	30691.366	135.046
14	3174.195	30667.331	135.309
15	3180.836	30643.329	135.583
16	3187.594	30619.359	135.867
17	3194.470	30595.423	136.162
18	3201.463	30571.520	136.465
19	3208.573	30547.653	136.769
20	3215.801	30523.820	137.073
21	3223.145	30500.024	137.377
22	3230.607	30476.263	137.681
23	3238.184	30452.540	137.985
24	3245.878	30428.854	138.288
25	3253.689	30405.206	138.592
26	3261.615	30381.597	138.896
27	3269.657	30358.	200
28	3277.8		
29			

Example 3

This example illustrates the use of appended sections, allowing the secondary interpolation tolerance to be changed for each portion of the long section.

SECTION, ROAD MODEL  
SECTION, REFERENCE MODEL  
017, 4=50, 9=250  
171, LINE, SINT, HARE, 6=10, 9=20

```
STRING HARE -----
```

NPT	-OFFSET-	-LEVEL-	NPT	-OFFSET-	-LEVEL-	NPT	-OFFSET-	-LEVEL-
1	0.000	50.000	3	69.563	50.000	5	105.789	50.000
2	34.781	50.000	4	87.676	50.000	6	150.000	53.976

NUMBER OF CUTS = 6

017, 4=20, 9=250  
171, LINE, SINT, HARE, 6=20, 9=30

```
STRING HARE -----
```

NPT	-OFFSET-	-LEVEL-	NPT	-OFFSET-	-LEVEL-	NPT	-OFFSET-	-LEVEL-
6	150.000	54.005	9	208.060	47.271	12	251.207	43.117
7	169.353	51.814	10	227.413	45.000	13	263.103	42.057
8	188.707	49.543	11	239.310	45.000	14	275.000	41.634

NUMBER OF CUTS = 9

017, 4=50, 9=250  
171, LINE, SINT, HARE, 6=30, 9=50

```
STRING HARE -----
```

NPT	-OFFSET-	-LEVEL-	NPT	-OFFSET-	-LEVEL-	NPT	-OFFSET-	-LEVEL-
14	275.000	41.663	17	382.779	40.000	20	470.012	45.000
15	288.518	40.000	18	386.803	40.231	21	499.118	45.000
16	335.649	40.000	19	428.408	42.615	22	528.224	45.000

NUMBER OF CUTS = 9

## Minor option 173 Cross - relative to a string

Extraction of a series of cross sections perpendicular to a previously created string.

### Input

#### Graphics

IGSECTT.DAT, SEC002, SEC006

SECTION option details	Cross - relative to string
Define section params	Section set initial char.
Define linear units	Reference string label
Define string masking	Secondary interpolation (T)
Long - between 2 points	Start chainage / X coord
Long - along a string	Start point no. / Y coord
Cross - relative to string	Leftmost offset
Cross - relative to master	End chainage / X coord
Visibility along section	End point no. / Y coord
Visibility against section	Rightmost offset
Long - thru triangulation	

### Linemode

#### Minor option 173

- \* Field 1 Reference string. The string may be any dimension (eg master alignment or simply two dimensions) and sections will be produced for all points on the string.
- Field 2 If secondary interpolation is required specify SINT.
- \* Field 3 Specify an initial character to give a unique reference to the stored sections eg C.
- Field 5 & 6 SPRD start.
- \* Field 7 Left most offset - specify sign if negative.
- Field 8 & 9 SPRD end.
- \* Field 10 Right most offset - specify sign if negative.

### Example

This example illustrates sections being taken along a three dimensional string C002 which represents the centre line of an existing road. Secondary interpolation is requested and the section strings are stored with labels commencing with the character F.

SECTION SAMPLE GROUND MODEL								
SECTION SECTIONS MODEL								
173C002SINTP								
	1.0	-40.0		7.0		40.0		
-----								
STRING F001								
NPT	-OFFSET-	-LEVEL-	NPT	-OFFSET-	-LEVEL-	NPT	-OFFSET-	-LEVEL-
1	0.000	46.332	3	11.078	47.871	5	24.248	49.974
2	7.700	47.458	4	17.753	48.770			
NUMBER OF CUTS = 5								
-----								
STRING F002								
NPT	-OFFSET-	-LEVEL-	NPT	-OFFSET-	-LEVEL-	NPT	-OFFSET-	-LEVEL-
1	-33.301	41.491	7	-0.320	48.018	13	8.632	49.538
2	-28.035	42.191	8	0.000	47.838	14	10.566	49.363
3	-26.351	42.225	9	2.955	47.990	15	17.593	50.258
4	-23.284	42.682	10	5.840	47.924	16	24.786	51.627
5	-3.434	46.639	11	6.240	48.128	17	34.319	53.082
6	-1.270	48.069	12	7.470	48.921			
NUMBER OF CUTS = 17								
-----								
STRING F003								
NPT	-OFFSET-	-LEVEL-	NPT	-OFFSET-	-LEVEL-	NPT	-OFFSET-	-LEVEL-
1	-35.389	41.951	7	-2.617	47.875	13	7.655	49.685
2	-24.766	43.145	8	-0.090	48.559	14	8.754	50.243
3	-6.798	46.391	9	0.000	48.516	15	10.887	50.038
4	-5.565	46.831	10	3.200	48.678	16	17.663	50.925
5	-4.368	47.434	11	5.960	48.615	17	25.324	52.292
6	-3.211	47.570	12	6.340	48.858	18	34.884	53.792
NUMBER OF CUTS = 18								
-----								
STRING F004								
NPT	-OFFSET-	-LEVEL-	NPT	-OFFSET-	-LEVEL-	NPT	-OFFSET-	-LEVEL-
1	-39.974	42.426	7	-1.270	49.237	13	7.452	50.314
2	-29.440	43.332	8	-0.250	49.392	14	8.630	50.840
3	-19.018	44.995	9	0.000	49.220	15	10.777	50.686
4	-8.596	47.369	10	3.060	49.320	16	17.605	51.550
5	-5.976	47.622	11	5.890	49.276	17	25.553	52.940
6	-3.298	48.016	12	6.240	49.491	18	35.179	54.462
NUMBER OF CUTS = 18								
-----								
STRING F005								
NPT	-OFFSET-	-LEVEL-	NPT	-OFFSET-	-LEVEL-	NPT	-OFFSET-	-LEVEL-
1	-39.716	43.242	7	0.000	49.830	13	10.785	51.299
2	-22.442	45.121	8	3.200	49.962	14	17.537	52.154
3	-5.168	48.064	9	5.970	49.915	15	25.946	53.575
4	-3.478	48.687	10	6.240	50.101	16	35.541	55.083
5	-1.660	50.004	11	7.604	51.043			
6	-0.260	50.057	12	8.591	51.460			
NUMBER OF CUTS = 16								
-----								
STRING F006								
NPT	-OFFSET-	-LEVEL-	NPT	-OFFSET-	-LEVEL-	NPT	-OFFSET-	-LEVEL-
1	-39.533	44.094	7	0.000	50.542	13	10.716	51.992
2	-34.809	44.353	8	3.110	50.639	14	17.546	52.785
3	-18.988	46.450	9	5.921	50.572	15	26.289	54.329
4	-3.167	49.332	10	6.251	50.752	16	35.943	55.789
5	-1.680	50.632	11	7.638	51.704			
6	-0.340	50.729	12	8.521	52.160			
NUMBER OF CUTS = 16								
-----								
STRING F007								
NPT	-OFFSET-	-LEVEL-	NPT	-OFFSET-	-LEVEL-	NPT	-OFFSET-	-LEVEL-
1	-39.056	45.015	7	0.000	51.254	13	10.945	52.696
2	-21.458	46.748	8	3.230	51.346	14	16.143	53.352
3	-3.860	49.707	9	6.190	51.241	15	26.942	55.093
4	-3.144	49.978	10	6.500	51.501	16	28.884	55.382
5	-1.480	51.375	11	7.727	52.312			
6	-0.210	51.485	12	8.542	52.869			
NUMBER OF CUTS = 16								

## Minor option 174 Cross - relative to a master

Extraction of a series of cross section perpendicular to a master alignment at a regular chainage interval.

### Input

#### Graphics

IGSECTT.DAT, SEC002, SEC007

SECTION option details	Cross - relative to master
Define section params	Section set initial char.
Define linear units	Reference string label
Define string masking	Secondary interpolation (T)
Long - between 2 points	Chainage interval
Long - along a string	Start chainage / X coord
Cross - relative to string	Start point no. / Y coord
Cross - relative to master	Leftmost offset
Visibility along section	End chainage / X coord
Visibility against section	End point no. / Y coord
Long - thru triangulation	Rightmost offset

### Linemode

#### Minor option 174

- Field 1 Reference string, must be a master alignment.
- Field 2 If secondary interpolation is required, code SINT.
- \* Field 3 Specify an initial character to give a unique reference to the stored sections eg D
- \* Field 4 Chainage interval between sections
- Field 5 & 6 SPRD start
- Field 7 Left most offset - specify sign if negative
- Field 8 & 9 SPRD end
- Field 10 Right most offset - specify sign if negative

This option is similar to minor option 173 but only applies to master alignments and sections are determined at regular chainage intervals. The start and end chainage need not be on a regular chainage interval but every point considered must exist on the master alignment.

### Example

```
MOSS>SECT,SIMPLE DESIGN GROUND,SIMPLE DESIGN ROAD
SECT  SIMPLE DESIGN GROUND          SIMPLE DESIGN ROAD
SECT>SECT,SECTIONS MODEL
SECT  SECTIONS MODEL
```

```

SECT>174,MAST,SINT,H,20,100,7=-40,140,10=40
174MASTSINTH      20      100      -40      140      40

STRING H00C--CHAINAGE =      100.000 -----

NPT  -OFFSET-  -LEVEL-  NPT  -OFFSET-  -LEVEL-  NPT  -OFFSET-  -LEVEL-

  1  -22.828  49.923  7  -1.573  53.220  13  11.447  55.073
  2  -15.373  50.793  8  1.437  53.090  14  18.678  56.118
  3  -8.132  51.846  9  1.786  53.306  15  28.330  57.622
  4  -6.320  53.292  10  2.705  54.063  16  38.149  58.944
  5  -4.950  53.332  11  3.787  54.660
  6  -4.734  53.178  12  5.841  54.415

NUMBER OF CUTS =      16

STRING H00F--CHAINAGE =      120.000 -----

NPT  -OFFSET-  -LEVEL-  NPT  -OFFSET-  -LEVEL-  NPT  -OFFSET-  -LEVEL-

  1  -23.529  51.465  7  -2.951  54.566  13  10.582  56.322
  2  -16.131  52.322  8  0.065  54.444  14  18.488  57.481
  3  -9.578  53.160  9  0.352  54.501  15  28.823  58.919
  4  -7.305  54.614  10  1.487  55.285  16  38.597  60.205
  5  -6.389  54.647  11  2.333  55.851  17  40.000  60.483
  6  -6.058  54.510  12  4.100  55.610

NUMBER OF CUTS =      17

STRING H00H--CHAINAGE =      140.000 -----

NPT  -OFFSET-  -LEVEL-  NPT  -OFFSET-  -LEVEL-  NPT  -OFFSET-  -LEVEL-

  1  -28.903  52.260  7  -8.076  55.932  13  2.449  56.984
  2  -26.932  52.464  8  -4.908  55.965  14  9.208  57.743
  3  -19.013  53.669  9  -2.058  55.892  15  18.089  58.959
  4  -11.243  54.682  10  -1.781  55.985  16  28.585  60.407
  5  -9.264  56.125  11  -0.550  56.753  17  38.293  61.640
  6  -8.409  56.083  12  0.219  57.187  18  40.000  61.888

NUMBER OF CUTS =      18

-----
SECT>999
999

MOSS>REPO,SECTIONS MODEL,SIMPLE DESIGN ROAD
REPO  SECTIONS MODEL      SIMPLE DESIGN ROAD

----- M O D E L  N A M E -----  RECORD  SECURITY  DATE LAST USED -----
SECTIONS MODEL      4559  FREE      21JAN91
SIMPLE DESIGN ROAD  2874  FREE      21JAN91
REPO>019,H,4=1
019H      1
REPO>019,4=-1
019      -1
REPO>992
992

LABEL  SUBREF  CONTENTS NO.PTS  X -MIN  Y -MIN  X -MAX  Y -MAX  RECORD LOC.
H00C  MAST      7705  16  501411  111172  501433  111230  4560  1

CHAINAGE      100.000
-----

POINT  -----X----- -----Y----- ----Z----- ---OFFSET--  -LABEL CUT-

  1  501432.433  111172.482  49.923  -22.828  F004
  2  501429.860  111179.478  50.793  -15.373  L006
  3  501427.361  111186.274  51.846  -8.132  T000
  4  501426.735  111187.975  53.292  -6.320  H001
  5  501426.263  111189.261  53.332  -4.950  V002
  6  501426.188  111189.464  53.178  -4.734  C002
  7  501425.097  111192.430  53.220  -1.573  C001
  8  501424.058  111195.255  53.090  1.437  C000
  9  501423.938  111195.583  53.306  1.786  V001
  10  501423.620  111196.445  54.063  2.705  V000
  11  501423.247  111197.461  54.660  3.787  F001
  12  501422.538  111199.389  54.415  5.841  L003
  13  501420.603  111204.650  55.073  11.447  L003
  14  501418.107  111211.437  56.118  18.678  L003
  15  501414.776  111220.496  57.622  28.330  L003
  16  501411.387  111229.711  58.944  38.149  L003

LABEL  SUBREF  CONTENTS NO.PTS  X -MIN  Y -MIN  X -MAX  Y -MAX  RECORD LOC.
H00F  MAST      7705  17  501392  111164  501414  111226  4560  161

CHAINAGE      120.000
-----

POINT  -----X----- -----Y----- ----Z----- ---OFFSET--  -LABEL CUT-

  1  501413.207  111164.958  51.465  -23.529  F004
  2  501410.845  111171.968  52.322  -16.131  L006
  3  501408.752  111178.178  53.160  -9.578  T000
  4  501408.026  111180.332  54.614  -7.305  H000
  5  501407.734  111181.200  54.647  -6.389  V002
  6  501407.628  111181.514  54.510  -6.058  C002
  7  501406.636  111184.458  54.566  -2.951  C001
  8  501405.673  111187.316  54.444  0.065  C000

```



9	501405.581	111187.588	54.501	0.352	V001			
10	501405.218	111188.664	55.285	1.487	V000			
11	501404.948	111189.466	55.851	2.333	F001			
12	501404.384	111191.140	55.610	4.100	L003			
13	501402.314	111197.283	56.322	10.582	L003			
14	501399.789	111204.775	57.481	18.488	L003			
15	501396.489	111214.569	58.919	28.823	L003			
16	501393.367	111223.831	60.205	38.597	L003			
17	501392.919	111225.160	60.483	40.000	*TR*			
LABEL	SUBREF	CONTENTS NO.PTS	X -MIN	Y -MIN	X -MAX	Y -MAX	RECORD	LOC.
H00H	MAST	7705	18	501374	111153	501396	111220	4560 331
						CHAINAGE	140.000	
						-----		
POINT	-----X-----	-----Y-----	-----Z-----	---OFFSET---	-LABEL	CUT-		
1	501395.096	111153.497	52.260	-28.903	F004			
2	501394.520	111155.382	52.464	-26.932	L007			
3	501392.207	111162.956	53.669	-19.013	L007			
4	501389.937	111170.387	54.682	-11.243	T000			
5	501389.358	111172.280	56.125	-9.264	H000			
6	501389.109	111173.097	56.083	-8.409	V002			
7	501389.011	111173.416	55.932	-8.076	C002			
8	501388.086	111176.446	55.965	-4.908	C001			
9	501387.253	111179.171	55.892	-2.058	C000			
10	501387.172	111179.436	55.985	-1.781	V001			
11	501386.813	111180.613	56.753	-0.550	V000			
12	501386.588	111181.349	57.187	0.219	F001			
13	501385.936	111183.482	56.984	2.449	L003			
14	501383.962	111189.946	57.743	9.208	L003			
15	501381.367	111198.439	58.959	18.089	L003			
16	501378.301	111208.477	60.407	28.585	L003			
17	501375.465	111217.762	61.640	38.293	L003			
18	501374.966	111219.394	61.888	40.000	*TR*			

## Minor option 175/176 Visibility along/against a section

This option allows visibility distances to be measured between an eye point of known position and height and a series of target points of known position and height in either direction along a reference string.

A sectional approach is adopted. A target positioned relative to a string over a series of sections is checked for visibility from an eye point positioned relative to a string on one section. The process of moving the target away from the eye point continues until visibility is lost or until a user defined minimum visibility distance is achieved. The point where visibility is lost is calculated using an approximate interpolation allowing the achieved visibility distance to be listed and stored if required. By default the eye and target intervals will be set to five times the section interval.

The relationship of eye and target points to their respective reference strings will be negative to the left and positive to the right in the direction of increasing chainage. The use of minor option 176 for reverse analysis will not affect this.

Any 175 or 176 minor options must be preceded by minor option 174. The initial minor option 174 creates the sections over which the visibility analysis is required and the section interval coded in the 174 minor option will determine the accuracy to which the visibility distance can be interpolated.

Graphics

IGSECTT.DAT, SEC002, SEC009

SECTION option details	Visibility along section
Define section params	Eye string label
Define linear units	Target string label
Define string masking	Visibility string label
Long - between 2 points	Min. visibility distance
Long - along a string	Eye horizontal offset
Cross - relative to string	Eye vertical offset
Cross - relative to master	Eye chainage interval
Visibility along section	Target horizontal offset
Visibility against section	Target vertical offset
Long - thru triangulation	Target chainage interval

IGSECTT.DAT, SEC002, SEC010

SECTION option details	Visibility against section
Define section params	Eye string label
Define linear units	Target string label
Define string masking	Visibility string label
Long - between 2 points	Min. visibility distance
Long - along a string	Eye horizontal offset
Cross - relative to string	Eye vertical offset
Cross - relative to master	Eye chainage interval
Visibility along section	Target horizontal offset
Visibility against section	Target vertical offset
Long - thru triangulation	Target chainage interval

Linemode

Minor option 175/176

- \* Field 1 String label to define the eye position
- \* Field 2 String label to define target position
- Field 3 Visibility string label if visibility details are to be stored
- \* Field 4 Minimum visibility distance
- Field 5 Eye horizontal offset
- Field 6 Eye vertical offset

Field 7	Eye chainage interval
Field 8	Target horizontal offset
Field 9	Target vertical offset
Field 10	Target chainage interval.

Option 176 allows the eye and target to run in the reverse direction along the master alignment without having to change the 174 data. Option 175 or 176 must be preceded by a 174 option which will provide some additional data, such as master alignment label, standard point reference data, and initial character of sections to be assessed by the visibility run. The eye and target chainage intervals must be integer multiples of the 'chainage interval between sections' entered in the 174 option.

The relationship of eye and target points to their respective reference strings will be negative to the left and positive to the right, in the direction of increasing point number. The use of option 176 for reverse analysis will not affect this.

### Example

Analyse the model DESIGN MODEL for a minimum visibility distance of 200m and store the results in VISIBILITY RESULTS.

```
SECT, DESIGN MODEL
SECT, VISIBILITY RESULTS
174, M001, SINT, V, 5, 7=-70, 10=70
175, CL01, CR01, VISI, 200, 2.0, 1.5, 25, -2, 0.25, 25
999
```

The initial 174 minor option demonstrates that the model DESIGN MODEL is to be sectioned at 5 metre intervals with a section width of 70 metres either side of M001. It must be ensured that the sections are sufficiently wide to allow for a visibility distance of 200m. Insufficiently wide sections will cause a 'SECTION TOO NARROW' error.

The 175 minor option shows that visibility analysis is required along M001 in a forwards direction with the eye point 2.0 metres to the right of CL01 and 1.5 metres above the section at the horizontal offset specified. The target point is 1.5 metres to the left of CR01 and 0.25 metres above the section. The interval at which both the eye and target points are to be placed along the sections is 25 metres.

At the first section the target is moved away from the eye point at 25 metre intervals until either a minimum visibility of 200 metres is achieved or until visibility of the target is lost.

When visibility is lost the target is repositioned at the section at which it was last visible and then moved away from the eye at the smaller section interval. In the example the target will be moved at the smaller 5 metre interval. When the two sections between which visibility is lost and the section causing the infringement are established an interpolative procedure takes over to calculate the actual visibility distance somewhere in between these two sections. See Figure 9 - 7.

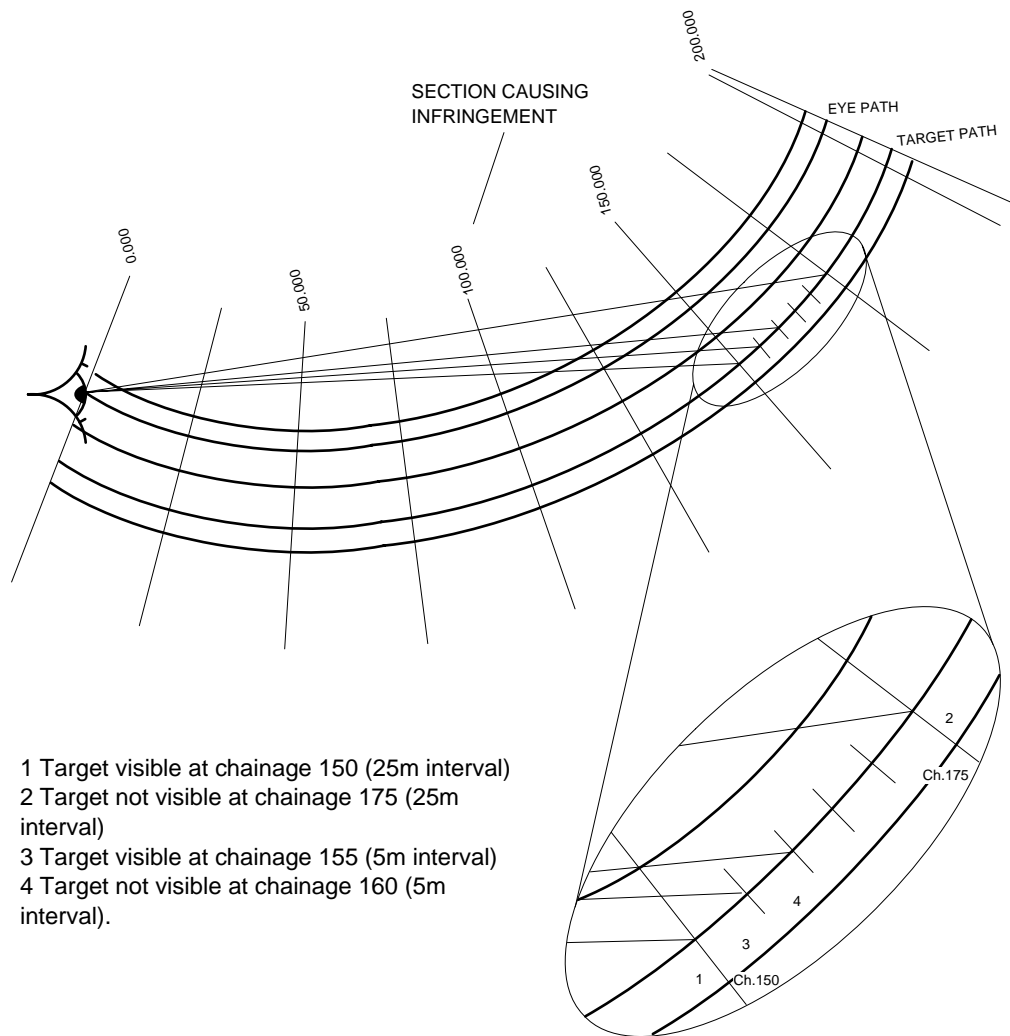


Figure 9 - 7 Example of visibility

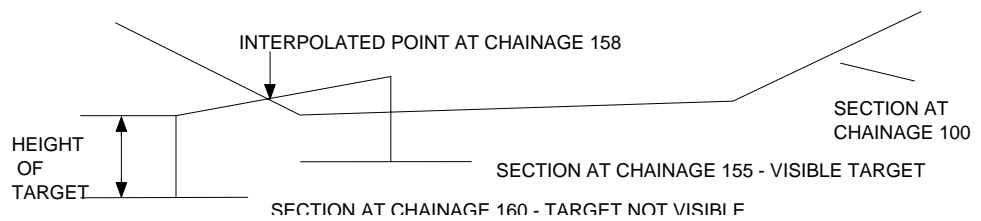


Figure 9 - 8 Sections restricting visibility

Imagine looking from the eye point towards the section at which visibility is lost. A line of sight is projected from the eye point through the interpolated point on the section to the target path. The distance between the eye point and where this line of sight intersects the target path is the calculated visibility distance. It is advisable to store the created visibility string in a separate model as the third dimension of the visibility string is an X coordinate and will be interpreted as a level should it be sectioned.

## Minor option 177 Long - through triangulation

Determination of a long section along a previously created string by threading through a triangulation.

### Input

### Graphics

IGSECTT.DAT, SEC002, SEC011

SECTION option detail:	Long - thru triangulation
Define section param:	Reference string
Define linear units:	Triangulation label
Define string masking:	Section label
Long - between 2 point:	Start chainage / X coord
Long - along a string:	Start point no / Y coord
Cross - relative to string:	End chainage / X coord
Cross - relative to master:	End point no. / Y coord
Visibility along section:	
Visibility against section:	
Long - thru triangulation:	

### Linemode

#### Minor option 177

- \* Field 1 Reference string
- \* Field 2 Triangulation label
- \* Field 3 Section label

If the label in field 3 is the same as the label in field 1, only levels on the reference string are amended.

Field 5 & 6 SPRD of start

Field 8 & 9 SPRD of end

◇ *A drainage string may be used as the reference string.*

**Derive the level at a point**

Minor option 177

- \* Field 2      Triangulation label
- Field 5 & 6   Code the easting and northing of the point.

**Derive the level of a point on a string**

Minor option 177

- \* Field 1      Reference string
  - \* Field 2      Triangulation label
  - Field 4      Code 1.0 to indicate single point identifier
  - Field 5 & 6   SPRD of point
- ◇ *This use of the option does not amend levels on the reference string.*

**Derive the levels at a series of points along a string**

Minor option 177

- \* Field 1      Reference string
  - \* Field 2      Triangulation label
  - Field 5 & 6   SPRD start
  - Field 8 & 9   SPRD end
- ◇ *This use of the option does not amend levels on the reference string.*

**Minor option 178    Cross - through triangulation**

Extraction of a series of cross section perpendicular to a previously created string at a regular interval by threading through a triangulation.

Input

Graphics

IGSECTT.DAT, SEC002, SEC012

SECTION minor options	Cross -thru triangulation
Long - thru triangulation	Reference string
Cross - thru triangulation	Triangulation label
End SECTION	Section set initial char.
	Chainage interval
	Start chainage / X coord
	Start point no / Y coord
	Leftmost offset
	End chainage / X coord
	End point no. / Y coord
	Rightmost offset

Linemode

Minor option 178

- \* Field 1 Reference string
- \* Field 2 Triangulation label
- \* Field 3 Section set initial character
- Field 4 Chainage interval, if blank use all points on the reference string
- Field 5 & 6 SPRD of start
- Field 7 Leftmost offset
- Field 8 & 9 SPRD of end
- Field 10 Rightmost offset.

Section drawing details

The SECTION drawing details menus are displayed after the creation and presentation of the sections in the graphics area. These allow you to draw the sections in a specified layout and to a specified scale. You may then save the DPF so that the section drawing may be recalled at a future date.

## Draw long sections

### Input

#### Graphics

IGSECTT.DAT, SEC015, SEC016

SECTION - drawing details	Draw long sections
Draw sections (T)	Horizontal scale
	Vertical scale
	PAGE (T)

**Horizontal scale** is the horizontal scale of the drawing (ie, 500 for 1:500). The default is 1:1000.

**Vertical scale** is the vertical scale of the drawing (ie, 500 for 1:500). The default is 1:100.

**PAGE** is a toggle which allows you to invoke automatic paging or to use one page only.



## Draw cross sections

### Input

#### Graphics

IGSECTT.DAT, SEC015, SEC017

SECTION - drawing details	Draw cross sections
Draw sections (T)	Horizontal scale
	Vertical scale
	PAGE (T)
	No. of rows
	No. of columns

**Horizontal scale** is the horizontal scale of the drawing (ie, 500 for 1:500). The default is 1:1000.

**Vertical scale** is the vertical scale of the drawing (ie, 500 for 1:500). The default is 1:100.

**PAGE** is a toggle which allows you to invoke automatic paging or to use one page only.

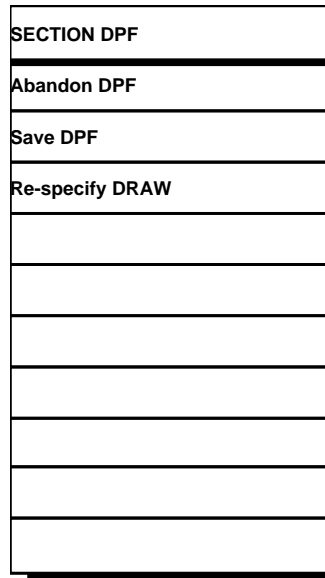
**No. of rows** is the number of rows containing cross sections

**No. of columns** is the number of columns containing cross sections

## Section DPF

Once the sections have been drawn, the 'SECTION DPF' menu is displayed.

**IGSECTT.DAT, SEC008**



**Abandon DPF** allows you to quit major option SECTION without saving the drawing.

**Save DPF** allows you to save the DPF for future use.

**Respecify DRAW** allows you to change values in the 'drawing details' menu and redraw the sections.

## Calculation of volumes

MOSS permits the determination of volumes between two model surfaces based on sectional information within a boundary or section limit. The options provided may be used to accurately determine the volumes of the most complex earthwork forms, such as highway interchanges and quarries and also the more regular earthworks of standard highway alignments. Additionally the calculated volumes may be stored in a model for subsequent use in mass haul analyses.

There are two methods for computing volumes using either parallel sections at constant intervals normal to a specified axis or sections at right angles to a given string. The choice of method will depend upon the complexity of the problem and the accuracy required. In highway design the two methods may be complementary, the volumes of interchange areas being determined by parallel sections and the volume of the intermediate highway, of regular profile, being determined by sections normal to a string, usually a centreline or channel.

A further simple method is provided for calculating volumes between a regular surface defined by a standard profile and a model. This feature is ideally suited for producing preliminary main route earthworks for highway route planning. Where volumes are a constant depth over a specified area, the major option AREA should be used.

Major option SURFACE and PRISM contain options which provide AREA and VOLUME information based on a triangulation of the surfaces.

### Method of computation

The method of computing volumes between two surfaces can be considered in three stages -

- Stage 1 The extraction of sections
- Stage 2 Formation of sectional polygons
- Stage 3 Calculation of volumes.

### Stage 1 The extraction of sections

First a series of sections is required through each model surface either at an interval along a specified axis or along a string. These sections may be derived automatically within the volume option, or be a series of previously stored sections, or in the case of the road model be defined by a standard section profile. Where sections have been derived previously using SECTION they can be used, removing the need to recompute them. However, it is essential that the two sets of sections are coincident in plan, ie that they were extracted with respect to the same axis or string at the same interval.

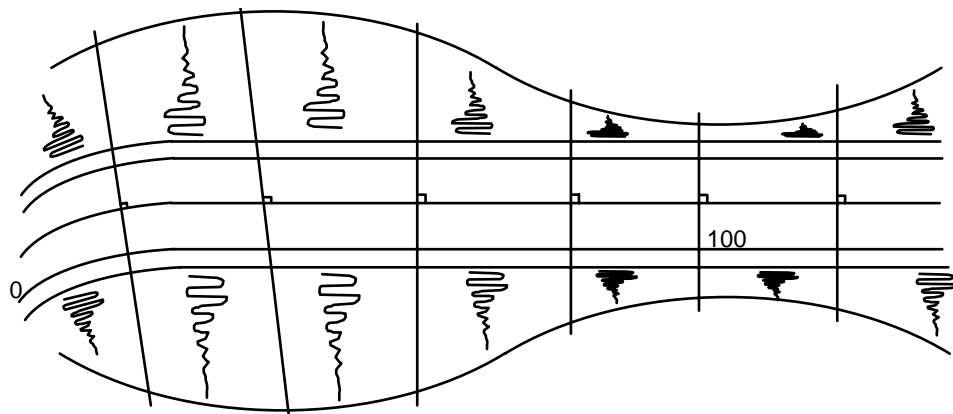
**Parallel sections**

The methods using parallel sections produce the most accurate volumes and can be considered as taking a series of elemental strips through the area. The interval between the sections may be as small as considered realistic and the accuracy of the result is influenced only by the model content and accuracy of the data used.

This method is ideally suited for determining the volumes of highway interchanges and other complex features such as quarries, stockpiles, land reclamation schemes etc. Applications show that for two independent calculations of the volumes of complex earthworks, where parallel sections are determined along different axes, the results compare to within two percent. Parallel sections avoid the errors introduced by the curvature when volumes are computed from sections taken normal to a string.

**Sections normal to a string**

This method has been most commonly used for highway earthwork calculations and although there are minor errors inherent in the method when the adjacent sections are not parallel, in many circumstances these errors are negligible and the method acceptable.

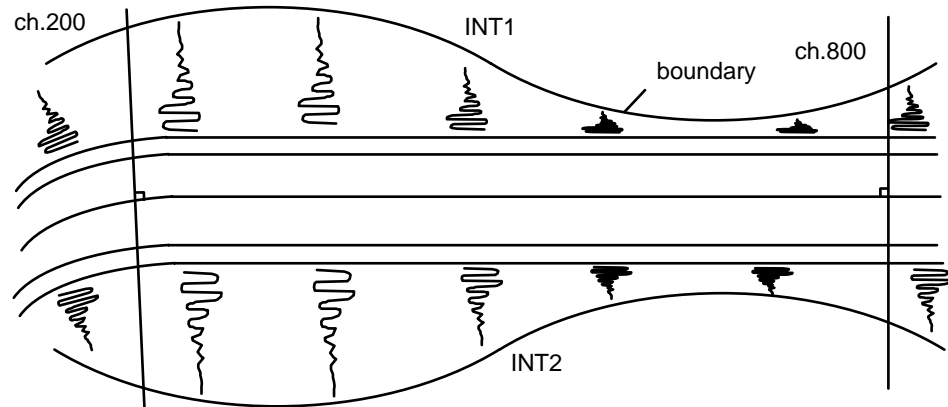


**Figure 9 - 9 Highway plan showing sections normal to a string**

For highways this method provides running volumes associated with the chainage of a reference string.

**Using boundary strings**

Boundary strings are used to define an area of interest and are usually created for temporary use. Unless the boundary represents an actual feature on the ground it should be excluded from the process of taking sections. The reason for this is that boundaries generated from several strings may not provide a correct vertical profile of the surface. This is illustrated in Figure 9 - 10.



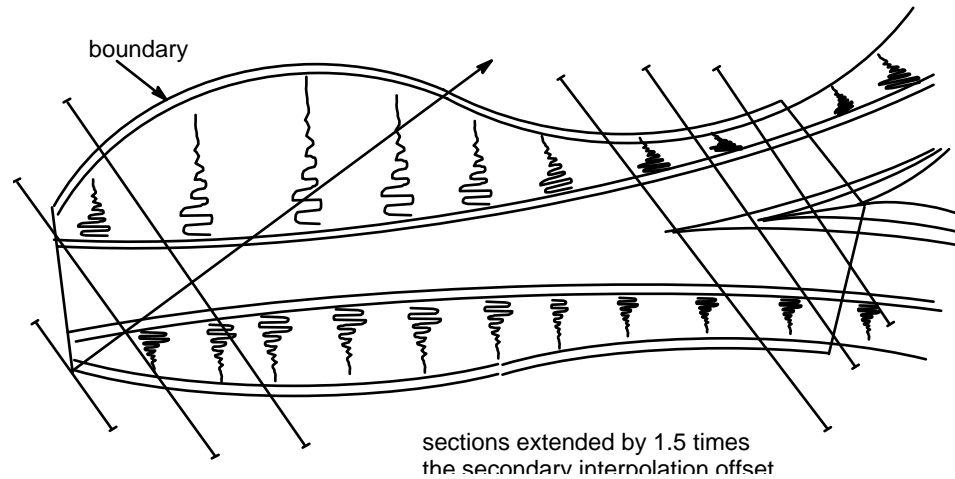
**Figure 9 - 10 Plan showing example boundary string**

The required volume is between the interface lines and chainages 200 and 800. The boundary is formed by joining strings INT1 and INT2. This is adequate but the boundary line at chainages 200 and 800 simply joins the two interface lines and is not representative of the ground or road model. To achieve accurate volumes the boundary at chainages 200 and 800 must be defined in both plan and elevation. You can do this by creating a section (SECTION 170) at the required limits of the road model, and using the section to provide the necessary definition.

Generally boundaries are only temporary features. Their permanent storage of them is not recommended as they may be inaccurate. The problem is easily resolved by masking out the boundary string. The mask facility allows the string to be retrieved from the model for the boundary but ensures it is ignored when sections are extracted. If several boundaries are stored within a model they all have to be masked out for each volume calculation.

### Parallel sections and boundary strings

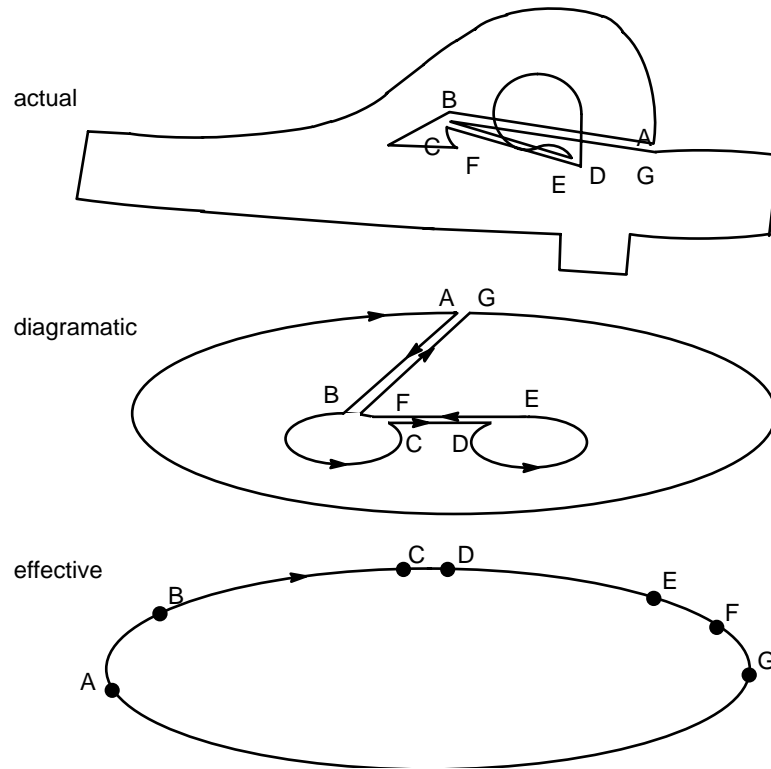
Within minor option 050 parallel sections are taken normal to a specified axis within a boundary. If the section interval is not specified the default of 25 equal intervals will be adopted. The limits of these sections are set to the boundary width plus a distance of 1.5 times the secondary interpolation offset each side of the boundary to ensure section definition along the boundary.



**Figure 9 - 11 Highway interchange plan showing parallel extended sections within a boundary**

### The complex boundary

The boundary may be of complex form as a continuous line linking internal loops. The parallel sections may intersect the boundary several times producing complex sections from which accurate volumes are calculated. The sequence of joining the internal boundaries, along coincident lines must ensure that when theoretically expanded, the boundary is an encompassing line with no intersections. The following diagram shows how this is achieved.



**Figure 9 - 12 The complex boundary**

Within minor option 052, sections are taken normal to a reference string and the intersection points with the boundary are determined. The search for the intersection points is limited to within the preset section offset tolerance of 100 units either side.

- ◇ *It is possible, where a reference string is highly curved, that a section having crossed out of the boundary could reenter the boundary and this would lead to incorrect volumes. Thus the section offset tolerance is critical and must be large enough to ensure that the sections cut the boundary, but small enough to ensure that the boundary is not reentered. The section offset tolerance can be amended with the 017 option.*
- ◇ *Once the intersection point of the section with the boundary has been found the section is extended by 1.5 times the secondary interpolation offset to ensure section definition across the boundary.*
- ◇ *There may be up to 3000 points on the boundary.*

### General sections

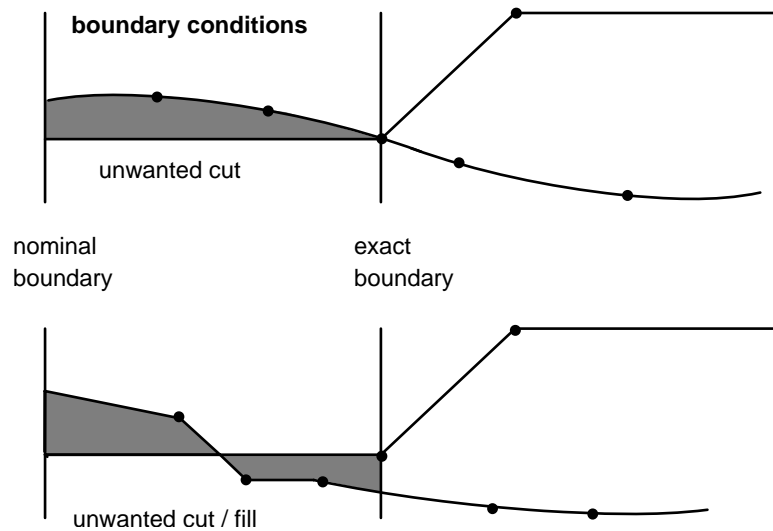
For minor option 053 there is no boundary to define the section limits. The initial section width is set to the default of 100 units either side of the reference string. The default can be changed with minor option 017 and must be large enough to ensure that the area where the volume is required is covered. (Similar considerations apply when using major option SECTION to store sections for subsequent use with minor options 054, and 056. and 057.)

## Stage 2 Formation of sectional polygons

The second stage is to form the corresponding sections into two polygons in the vertical plane. There may be certain cases where the section points will not form a closed polygon and it is necessary to make certain assumptions to extend or limit the sections as follows;

### Defined boundaries

Where boundaries are defined in options 050 and 052, the sections for the two surfaces are joined at the boundary. It is very important that the boundary string follows the exact extent of the area for which the volume is required. Where section detail falls short of the boundary the sections are extended laterally and this can produce unwanted quantities as illustrated.



**Figure 9 - 13 Section showing boundaries unmatched in plan**

### Incomplete boundaries

Where boundaries are incomplete the sections are closed in the following manner.

- The sections from the second model, or assumed new surface, terminate at vertical lines through the extreme leftmost and rightmost points, Figure 9 - 14a
- The sections from the first model, or assumed existing surface, are extended laterally, Figure 9 - 14b
- The points of closure to the left and right of the section are where these two lines intersect, Figure 9 - 14c.



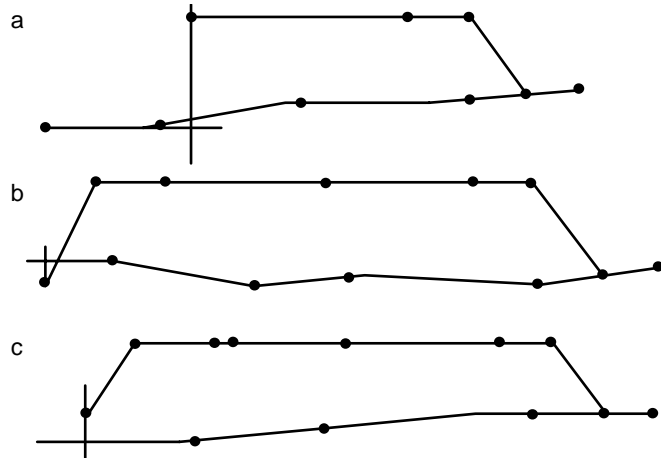
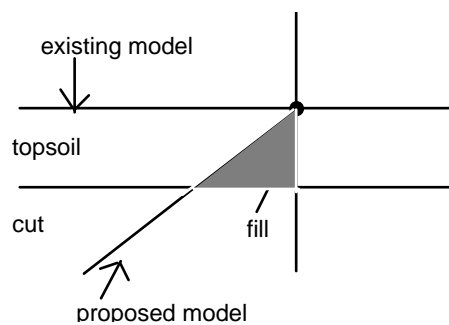


Figure 9 - 14 Closing section polygons with incomplete boundaries

### Stage 3 Calculation of volumes

Volumes which do not allow for curvature corrections are determined between adjacent sections by multiplying the average of the two successive polygon areas by the intervening distance. If one or a pair of sections do not exist they are simply ignored and the distance between the adjacent sections is used to determine the through volume.

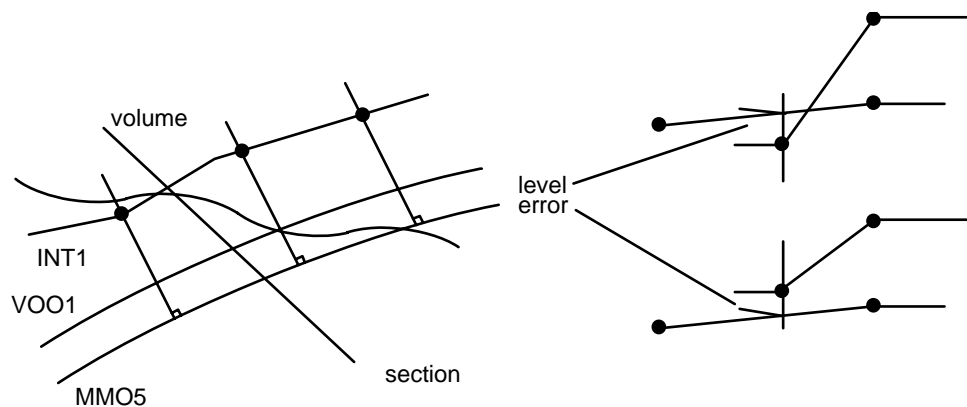
If a top soil depth is specified the sections from the first model, or assumed existing surface, are reduced in height by this amount. This technique may produce minute quantities of fill in areas of cut or cut in areas of fill, when the topsoil is almost equal to the soiling depth.



**Figure 9 - 15 Sections showing small cut/fill errors due to soiling**

Small volumes of cut and fill can be calculated at locations where they are not expected. These small errors will occur if the interface strings have been created from a different reference string to that which has been used for the ground sections.

Figure 9 - 15 shows how the errors occur because the volume sections interpolate points between them on the interface string. These errors are minimised if the interface is used as the boundary. Obviously these errors do not occur if the sections used to determine the interface are coincident with the sections used to calculate the volume.



**Figure 9 - 16 Errors due to difference in interface/ground level**

**Curvature corrections**

Curvature corrections may be introduced into the volume calculation by taking into account the radius of the alignment at adjacent cross sections and the distance of the centre of gravity of the cross sections from the centre line.

When curvature corrections are considered, the volume of cut/fill between two sections is given by:

$$V_{ab} = D \frac{(A_a + A_b)}{2} \frac{(K_a + K_b)}{2}$$

where:

$A_a$  and  $A_b$  are the areas of sections A and B

$K_a$  and  $K_b$  are the curvature correction (k) factors of sections A and B

$D$  is the distance between the two sections

The curvature correction, or k, factor is given by:

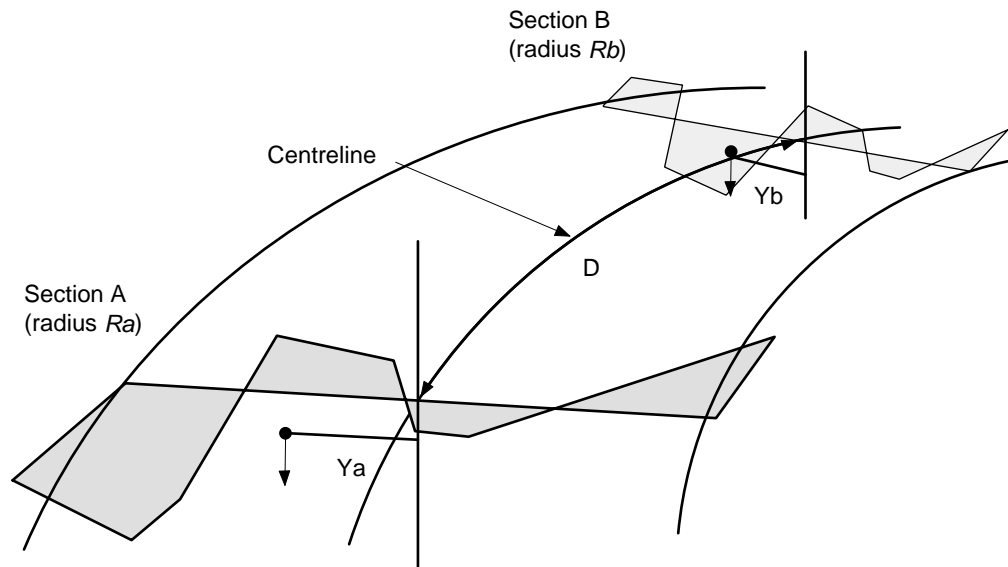
$$K_n = \frac{R_n - Y_n}{R_n}$$

where:

$K_n$  is the curvature correction factor of section N

$R_n$  is the radius at section N

$Y_n$  is the offset of the acting centre of gravity of section N from the centreline



**Figure 9 - 17 Curvature correction calculations**

If a section lies on a discontinuity, ie, where there is an instantaneous change in radius, two different radii are used to calculate different k factors for the preceding and following volumes.

Discontinuities which lie between sections may be ignored. This is because the errors introduced by these discontinuities are minimal and partially self

correcting. Any small errors can be reduced by using a smaller section interval.

## Major option VOLUME

Volumes in MOSS are calculated from sectional information within a boundary or section limits. Several minor options are available for the determination of volumes for various situations and accuracies.

The minor options provided are

- 050            Volume using parallel sections.  
Calculate volumes between two models inside a boundary string using parallel sections.
- 051            Volume environment  
Specifies certain aspects of the volume output layout, allowing an initial value to be added to the calculated volume and an output summary to be included. Curvature correction may also be switched on or off.
- 052            Volume using cross sections.  
Calculate volumes between two models within a boundary string using cross sections normal to a reference string.
- 053            Auto standard profile.  
Calculate volumes between a model and a 'standard profile' (see 055) using cross sections normal to a reference string.
- 054            Standard profile and existing sections.  
Calculate volumes between an existing set of sections (produced by major option SECTION) and a 'standard profile'.
- 055            Define a standard profile. For use in minor option 053/054.
- 056            Two existing cross sections.  
Calculate volumes between two existing sets of sections (produced by major option SECTION) from a reference string.
- 058            Storage of calculated volumes information in a string.

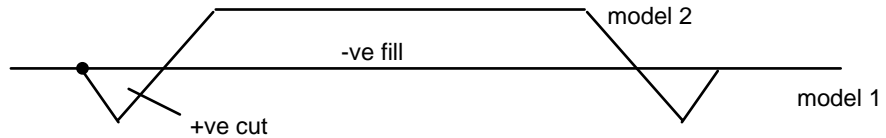
The procedure for calculating volumes is to initially determine sections at the appropriate direction and spacing through the two defined models. Each of the pairs of sections produces a closed polygon for which the area is calculated.

A facility is included to allow a topsoil depth to be specified and in this instance the levels from the appropriate set of sections are reduced by this amount prior to the formation of the polygons.

The required volumes are determined between adjacent sections by multiplying the average of the two successive polygon areas by the distance between them. These intermediate volumes are printed out together with the running volumes at each section. The running volumes printed at a section are the total volumes up to that section (the calculation does NOT span the section by half the adjacent interval distances). For options 052, 053, 054 and 056 the distance between the sections is calculated along the reference string which was used to extract the sections.

**Conventions**

Where two models are interrogated, producing two sets of sections, the volumes are assumed to be positive where Model 1 is above Model 2. Therefore it is conventional to give existing surfaces as Model 1 and new surfaces as Model 2 such that 'fill' is negative and 'cut' is positive.



**Figure 9 - 18 Example cut and fill**

In options 053/054 where only one model yields a set of cross sections, the standard profile is assumed to be equivalent to Model 2 (ie new surface). Where topsoil depths are specified they apply to the sections specified in the first model which is the existing surface as described above. In options 050 and 052 where boundary definition is required. Model 2 is searched first, if the boundary is not found, Model 1 is searched.

**Access to major option VOLUME**

IGENLT.DAT, GEN002, IGVOLUT.DAT, VOL001, VOL002

ANALYSIS OPTIONS	Models for VOLUME	VOLUME minor options
AREA	Existing/Sections model	Define system parameters
TRIANGLE	Proposed/Reference model	Define linear units
SECTION	Model to store volumes	Define string masking
<b>VOLUME</b>		Volume environment
SURFACE		Using parallel sections
PRISM		Using cross sections
		Auto standard profile
EDIT		Using exist cross sections
COPY		Define standard profile
REPORT		2 exist. cross sections

Selection of VOLUME in the top level menu will cause display of the Model for VOLUME menu.

## Model for VOLUME

### 1st Model 1

- for options 050, 052, 053 and 054 the model defining the existing surface
- for options 050 and 052 the model containing the boundary string, if it does not exist in the second model.
- for option 056 and 057 the model containing both sets of sections.

### 2nd Model 2

- for options 050 and 052 the model containing the new surface and boundary string
- for options 056 and 057 the model containing both sets of sections
- for options 052, 053, 054 and 056 the model containing the cross section reference string.

### 3rd Model 3

- for all options the model for storing volume strings and End Area strings.. (This record is only needed if volumes information is to be stored).

## Global minor options

The global options 000, 017, 019, 900 and 999 may be used with VOLUME.

**Minor option 017 Define system parameters**

This minor option may be used to define required parameters prior to the volume options.

**Input**

IGVOLUT.DAT, VOL002, VOL003a, VOL003b

VOLUME minor options	Define system parameters	Define system parameters
Define system parameters	Curve fitting status (T)	Survey station str label
Define linear units	Input coord notation (T)	Secondary interp. tolerance
Define string masking	Angular input units (T)	Point search tolerance
Volume environment	English/French design (T)	Left section offset tol.
Using parallel sections	Triangle error echo (T)	Section baseline bearing
Using cross sections	Triangle FLAT/NO FLAT (T)	Secondary interp. offset
Auto standard profile	French Road type (T)	Right section offset tol.
Using exist cross sections	Output coord notation (T)	
Define standard profile	Angular output units (T)	
2 exist. cross sections	Survey station str label	

**Linemode**

**Minor option 017**

- Field 4      Secondary interpolation tolerance, default 20.0.
- Field 7      Section offset tolerance left, (default - 100.0).
- Field 8      Bearing of baseline for automatic sections, default centesimal (option 050).
- Field 9      Secondary interpolation offset, default equal to secondary interpolation tolerance.
- Field 10     Section offset tolerance right, (default + 100.0).



Minor option 019 String masking

This option may be used to define masks to exclude or select strings from the searches when determining section information, but when two different models are interrogated, difficulty may arise if strings from both models satisfy a mask and are acceptable in one model, but not the other. In this case, string re-labelling options may be used to clear the problem.

Minor option 050 Volume using parallel sections

Calculate volumes between two models inside a boundary using sections normal to a specified axis.

Input

Graphic

IGVOLUT.DAT, VOL002, VOL004

VOLUME minor options	Using parallel sections
Define system parameters	Sint (T)
Define linear units	Boundary string label
Define string masking	Topsoil depth
Volume environment	Cross section interval
Using parallel sections	Hatching default (T)
Using cross sections	
Auto standard profile	
Using exist. cross sections	
Define standard profile	
2 exist. cross sections	

Linemode

Minor option 050

- Field 2 If secondary interpolation is required code SINT.
- \* Field 3 The boundary string label.
- Field 7 Topsoil depth
- Field 10 The required cross section interval. If blank an interval of 1/25 of the axis length is assumed.

The bearing of the baseline generating the sections is assumed to be 0.0 angular units. This may be altered by defining the required value with the 017 minor option.

Example 1

Figure 9 - 19 illustrates a highway interchange. A boundary has been constructed, using the EDIT options 009 and 010, defining the limits of the interchange and the quantities are required between the new road model NW 500 SCHEME and ground model EXISTING GROUND. Parallel sections are required at 5 metre intervals with the secondary interpolation tolerance set to 10.0 and the secondary interpolation offset set to 30.0.

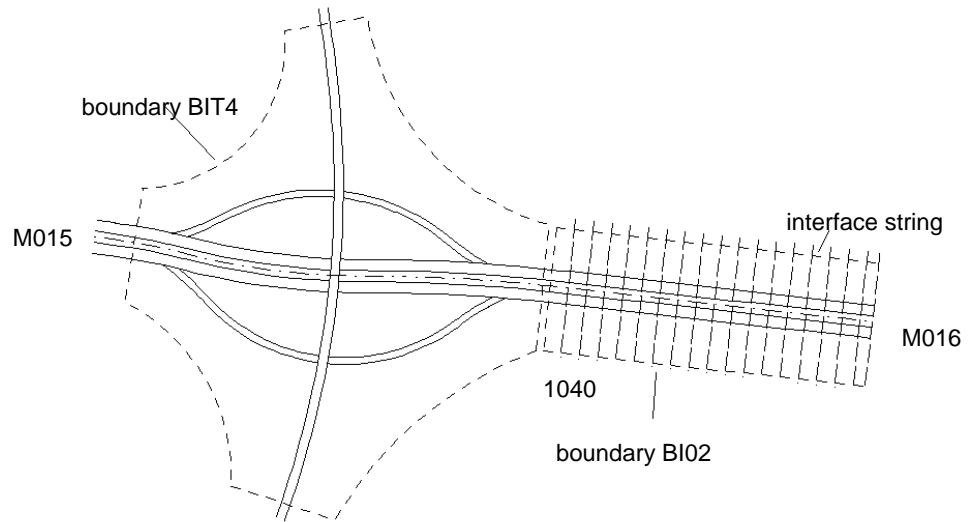


Figure 9 - 19 NW 500 SCHEME – Highway interchange

```
VOLUME, EXISTING GROUND, NW 500 SCHEME
017, , , , 10.0, 9=30.0
050, , SINT, BIT4, 10=5.0
999
```

Example 2

The boundary string BDRY is created around a highway interchange. The sections are to be taken normal to an axis of bearing 45.0 degrees at intervals of 50.0 units. Secondary interpolation tolerance and offset are set to 50 units.

```
VOLUME, THORNBROUGH GROUND MODEL, NEW SUBSURFACE MODEL
019, BDRY, 4=-1.0
017, , , , 20.0, 8=135.0, 50.0
050, , SINT, BDRV, 7=1.0, 10=50.0
999
```

```
VOLUME THORNBROUGH GROUND MODEL NEW SUBSURFACE MODEL
MASK THE BOUNDARY STRING FROM THE SECTION DETERMINATION
019BDRV -1
AXIS FOR SECTIONS SET AT 135 DEGREES
017 20 135. 50
W120 SYSTEM VALUES HAVE BEEN MODIFIED
VALUES ADOPTED :
SEARCH TOLERANCE 0.0100
LEFT OFFSETS -100.0000
RIGHT OFFSETS 100.0000
SECONDARY TOLERANCE 20.0000
```

```

SECONDARY OFFSET          50.0000
REFERENCE ANGLE          135.00000
CURVE FITTING INVOKED
STANDARD CONTENTS          7700
STATIONS STRING          PSSA
ANGLE DEFINITION:
INPUT: NORM OUTPUT: NORM
COORDINATE DEFINITION:
INPUT: XY   OUTPUT: XY
STANDARD DESIGN RULES APPLIED.

050   SINTBDRV          1          50

VOLUME WITHIN BOUNDARY DESIGNATED 'BDRV'

BASELINE DETAILS :
START POINT          3045.5316          30977.9506 FINISH POINT          4242.0500          29781.4321
MAXIMUM LEFT OFFSET          -58.8060 MAXIMUM RIGHT OFFSET          790.2120
NUMBER OF SECTIONS - 35 AT          50.000 INTERVAL, PERPENDICULAR TO A LINE AT AN ANGLE OF 135.0000 DEGREE

-CHAINAGE-          ---SECTIONAL AREAS---          -INTERMEDIATE VOLUMES-          -ACCUMULATIVE VOLUMES-
/DISTANCE-          ---CUT---          ---FILL---          ---CUT---          ---FILL---          ---CUT---          ---FILL---

                                W821 SECTION 2 CH 0.000 OMITTED
                                W820 SECTIONAL AREA AT CHAINAGE
                                0.000 ASSUMED ZERO
                                0.000          0.00

          0.000          0.000          0.000          1205.501          -341.609          1205.501          -341.609
          50.000          48.220          -13.664          1735.836          -917.546          2941.337          -1259.155
          100.000          21.213          -23.038          1146.087          -1163.566          4087.423          -2422.721
          150.000          24.630          -23.505          882.545          -2375.043          4969.968          -4797.764
          200.000          10.672          -71.497          308.013          -5384.698          5277.981          -10182.462
          250.000          1.649          -143.891          41.221          -9928.194          5319.202          -20110.656
          300.000          0.000          -253.236          0.000          -17312.913          5319.202          -37423.568
          350.000          0.000          -439.280          0.000          -24495.052          5319.202          -61918.620
          400.000          0.000          -540.522          0.000          -29889.026          5319.202          -91807.646
          450.000          0.000          -655.039          0.000          -35885.458          5319.202          -127693.104
          500.000          0.000          -780.379          0.000          -42482.457          5319.202          -170175.560
          550.000          0.000          -918.919          0.000          -49937.836          5319.202          -220113.397
          600.000          0.000          -1078.594          0.000          -60946.641          5319.202          -281060.038
          650.000          0.000          -1359.271          0.000          -80075.140          5319.202          -361135.178
          700.000          0.000          -1843.734          0.000          -105359.908          5319.202          -466495.085
          750.000          0.000          -2370.662          0.000          -131879.557          5319.202          -598374.64
          800.000          0.000          -2904.520

999

```

## Minor option 051 Volume environment

Specifies certain aspects of the volume output layout, allowing an initial value to be added to the calculated volume and an output summary to be produced. Curvature correction may also be switched on or off.

Input

Graphic

IGVOLUT.DAT, VOL002, VOL012

VOLUME minor options	Volume environment
Define system parameters	Printout heading for Cut
Define linear units	Column 1 text
Define string masking	Cut initial volume
Volume environment	Printout heading for Fill
Using parallel sections	Column 1 text
Using cross sections	Fill initial volume
Auto standard profile	Curve corrections (T)
Using exist. cross sections	Format for output (T)
Define standard profile	
2 exist. cross sections	

Linemode

Minor option 051

Fields 1 & 2 Text to be displayed in each row of the 'Position' column of the volume output (maximum 8 characters).

Field 4 Cut/fill indicator  
1 = cut, 2=- fill

Field 5 Curvature correction indicator  
0 = curve correction off  
1 = curve correction on

Curve correction may be used by minor options 052 and 056.

Field 6 Output format  
0 = full output (default)  
1 = full output with summary  
2 = summary only

Field 7 Initial volume. The value specified must be positive.

Field 10 Title indicator  
1.0 = title follows in a 001 record. The title can have a maximum of 80 characters.

Example 1

VOLUME, HAVERHILL GROUND SECTIONS, HAVERHILL DESIGN  
 051,4=1,1,7=1253.210,10=1  
 001,Cut volumes as measured on 1/9/91 at 10 am  
 051,4=2,1,7=2388.995,10=1  
 001,Fill volumes as measured on 1/9/91 at 10 am  
 056,MD03,G,R,5=240,8=416.5  
 999

VOLUME CALCULATIONS FROM CROSS SECTIONS

POSITION	CHAINAGE	AREA	VOLUME	RADIUS	Ys	K FACTOR	ADJUSTED VOLUMES	ACCUMULATIVE VOLUMES
							INITIAL VOLUME	1253.210
Cut volumes as measured on 1/9/91 at 10 am								
CUT	240.000	0.000	0.000	INFINITY	0.000	1.0000000	0.000	1253.210
CUT	260.000	0.000	0.000	INFINITY	0.000	1.0000000	0.000	1253.210
CUT	280.000	11.834	118.341	INFINITY	-3.112	1.0000000	118.341	1371.551
CUT	300.000	28.233	360.631	INFINITY	1.020	1.0000000	360.631	1735.182
CUT	300.000	28.233		396.065	1.020	0.9734495		1735.182
CUT	320.000	0.000	282.333	396.065	1.020	0.9734495	255.345	1990.527
CUT	340.000	10.539	105.390	396.065	-0.639	1.0916134	105.390	2095.917
CUT	360.000	1.231	112.310	396.065	-1.139	1.2023455	121.330	2108.247
CUT	380.000	1.354	13.037	467.354	-0.833	1.1327824	16.081	2124.328
CUT	400.000	25.677	129.644	INFINITY	-0.546	1.0000000	129.644	2253.972
CUT	416.500	0.000	84.700	INFINITY	-0.123	1.0000000	84.700	2338.672

VOLUME CALCULATIONS FROM CROSS SECTIONS

POSITION	CHAINAGE	AREA	VOLUME	RADIUS	Ys	K FACTOR	ADJUSTED VOLUMES	ACCUMULATIVE VOLUMES
							INITIAL VOLUME	2388.995
Fill volumes as measured on 1/9/91 at 10 am								
FILL	240.000	10.988	0.000	INFINITY	0.000	1.0000000	0.000	2388.995
FILL	260.000	8.432	94.432	INFINITY	0.000	1.0000000	94.432	2483.427
FILL	280.000	9.111	87.452	INFINITY	-1.531	1.0000000	87.452	2570.879
FILL	300.000	1.043	49.523	INFINITY	-0.531	1.0000000	49.523	2620.402
FILL	300.000	1.043		396.065	-0.531	0.9823470		2620.402
FILL	320.000	12.756	68.273	396.065	1.323	1.1239945	72.543	2692.945
FILL	340.000	6.431	91.420	396.065	2.351	1.3723679	126.121	2819.066
FILL	360.000	14.654	102.125	396.065	1.901	1.3015342	132.058	2951.124
FILL	380.000	14.742	146.432	467.354	2.427	1.3111628	169.218	3120.342
FILL	400.000	6.783	100.553	INFINITY	1.056	1.0000000	100.553	3220.895
FILL	416.500	0.000	54.122	INFINITY	1.056	1.0000000	54.122	3275.017

Example 2

This example (in German) shows the effect of specifying text for column 1 of the output.

```
VOLU, PFUNGSTADT GELANDEMODELL, PFUNGSTADT ENTWURFFMODELL
051, - 10 -, 4=1, 1, 7=1253.210, 10=1
001, Abtrag berechnet am 9/9/91 um 10.00
051, - 40 -, 4=2, 1, 7=2388.995, 10=1
001, Auftrag berechnet am 9/9/91 um 10.00
056, MD03, G, E, 5=240, 8=416.5
999
```

MASSENBERECHNUNG AUS QUERPROFILIEN

POSITION	STATION	FLAECHE	MASSE	RADIUS	Ys	K FAKTOR	K-MASSE	GESAMTMASSE		
Abtrag berechnet am 9/9/91 um 10.00								VORGABEMASSE	1253.210	- 40 -
240.000	0.000	0.000	0.000	0.000	1.0000000	0.000	1253.210			
- 40 -	260.000	0.000	0.000	0.000	0.000	1.0000000	0.000	1253.210		
- 40 -	280.000	11.834	118.341	0.000	-3.112	1.0000000	118.341	1371.551		
- 40 -	300.000	28.233	360.631	0.000	1.020	1.0000000	360.631	1735.182		
- 40 -	300.000	28.233		396.065	1.020	0.9734495		1735.182		
- 40 -	320.000	0.000	282.333	396.065	1.020	0.9734495	255.345	1990.527		
- 40 -	340.000	10.539	105.390	396.065	-0.639	1.0916134	105.390	2095.917		
- 40 -	360.000	1.231	112.310	396.065	-1.139	1.2023455	121.330	2108.247		
- 40 -	380.000	1.354	13.037	467.354	-0.833	1.1327824	16.081	2124.328		
- 40 -	400.000	25.677	129.644	0.000	-0.546	1.0000000	129.644	2253.972		
- 40 -	416.500	0.000	84.700	0.000	-0.123	1.0000000	84.700	2338.672		

MASSENBERECHNUNG AUS QUERPROFILIEN

POSITION	STATION	FLAECHE	MASSE	RADIUS	Ys	K FAKTOR	K-MASSE	GESAMTMASSE		
Auftrag berechnet am 9/9/91 um 10.00								VORGABEMASSE	2388.995	- 10 -
240.000	10.988	0.000	0.000	0.000	1.0000000	0.000	2388.995			
- 10 -	260.000	8.432	94.432	0.000	0.000	1.0000000	94.432	2483.427		
- 10 -	280.000	9.111	87.452	0.000	-1.531	1.0000000	87.452	2570.879		
- 10 -	300.000	1.043	49.523	0.000	-0.531	1.0000000	49.523	2620.402		
- 10 -	300.000	1.043		396.065	-0.531	0.9823470		2620.402		
- 10 -	320.000	12.756	68.273	396.065	1.323	1.1239945	72.543	2692.945		
- 10 -	340.000	6.431	91.420	396.065	2.351	1.3723679	126.121	2819.066		
- 10 -	360.000	14.654	102.125	396.065	1.901	1.3015342	132.058	2951.124		
- 10 -	380.000	14.742	146.432	467.354	2.427	1.3111628	169.218	3120.342		
- 10 -	400.000	6.783	100.553	0.000	1.056	1.0000000	100.553	3220.895		
- 10 -	416.500	0.000	54.122	0.000	1.056	1.0000000	54.122	3275.017		

Example 3

This example calculates volumes based upon G and D sections and outputs the results as a summary only.

```
VOLUME, SIMPLE DESIGN SECTIONS, SIMPLE DESIGN ROAD
VOLUME, SIMPLE DESIGN VOLUMES
051, 6=2
056, MAST, G, D
999
```

```
VOLUME SIMPLE DESIGN SECTIONS          SIMPLE DESIGN ROAD
VOLUME SIMPLE DESIGN VOLUMES
056MASTG D
-- VOLUME SUMMARY --
NUMBER OF SECTIONS WITH INITIAL LETTER 'G' IS 31
NUMBER OF SECTIONS WITH INITIAL LETTER 'D' IS 31
START CHAINAGE          :      0.000
END CHAINAGE            :     200.000
LENGTH OF SECTION      :     200.000
CUT VOLUME              :      0.000
FILL VOLUME             :    -11172.340
TOPSOIL VOLUME         :     1287.987
```

## Minor option 052 Volume using cross sections

Calculate volumes between two models within a boundary string using cross sections normal to a reference string.

The reference string need not be a master alignment unless curve corrections are required. For example, when the master alignment has been analysed in a channel position, and the centre line of the alignment is constructed from this string, the centre line string would be the reference string. If the reference string is not a master alignment sections will be taken through each point on the reference string between and including the start and end points.

### Input

### Graphic

IGVOLUT.DAT, VOL002, VOL005

VOLUME minor option:	Using cross sections
Define system parameter:	Reference string label
Define linear unit:	Volume string label
Define string masking	End Area string label
Volume environmen	Secondary interpolation (T)
Using parallel section:	Boundary string label
Using cross section:	Cross section interval
Auto standard profil	Start X Y
Using exist. cross section:	Topsoil depth
Define standard profil	End X Y
Using exist. cross section:	Hatching default (T)

### Linemode

#### Minor option 052

- \* Field 1 Reference string label

- If curve correction is on, this string must be a master alignment string.
- Field 2 If secondary interpolation is required code SINT
- \* Field 3 Boundary string
- Field 4 Cross section interval on reference string, only coded if the reference string is a master alignment.
- Field 5 & 6 SPRD start
- Field 7 Topsoil depth
- Field 8 & 9 SPRD end

**Example**

Figure 9 - 19 illustrates a highway interchange and dual carriageway. The volume of the dual carriageway is determined by creating a boundary string, B102 around the area and taking sections at right angles to string M016 between chainages 1040.0 to 2060.0.

```
VOLUME, EXISTING GROUND, NW 500 SCHEME
052, M016, SINT, B102, 20.0, 1040.0, , , 2020.0
```

**Minor option 053 Auto standard profile**

Calculate volumes between a model and a standard profile using cross sections normal to a reference string.

**Input**

**Graphic**

IGVOLUT.DAT, VOL002, VOL006, VOL008

VOLUME minor options	Auto standard profile	Define standard profile
Define system parameters	Reference string label	Start/end point (T)
Define linear units	Volume string label	Offset from ref. string
Define string masking	End Area string label	Level from ref. string
Volume environment	Sint (T)	Slope in cut
Using parallel sections	Cross section interval	Slope in fill
Using cross sections	Start X/Y	
Auto standard profile	Topsoil depth	
Using exist. cross sections	End X/Y	
Define standard profile	Hatching default (T)	
2 exist. cross sections		



- ◇ *The standard profile is set up using minor option 055 which automatically follows option 053. When the VOLUME 055 menu is first displayed you are prompted to define the start offset of the standard profile. VOLUME 055 will automatically prompt for the next offset. It will continue to prompt until you change the start/end point toggle to end.*

Linemode

The standard profile is set up using minor option 055 which must follow each 053 option ie they must be redefined for further 053 options in the same entry to the major option.

Minor option 053

- \* Field 1 Reference string for cross sections (need not be a master alignment).
- Field 2 If secondary interpolation is required code SINT
- Field 4 Cross section interval, coded if reference string is a master alignment.
- Field 5 & 6 SPRD start
- Field 7 Topsoil depth.
- Field 8 & 9 SPRD end

The printout details the running volumes and in addition lists the interface offsets at each chainage which may be used for the plotting of preliminary design land requirements.

Example

This example illustrates a simple two point section used to determine preliminary earthworks and interface offsets. The second model stores the reference string M003 for the standard profile.

```
VOLUME, THORNBROUGH GROUND MODEL, VOLUME MODEL
053, M003, 4=100.0, 3900.0, 8=5700.0
055, START, 4=-43.5, 0.0, 0.5, 0.5.
055, END, 4=43.5, 0.0, 0.5, 0.5.
999
```

VOLUME THORNBROUGH GROUND MODEL		NEW THORNBROUGH		
VOLUME	VOLUME MODEL			
053M003	100.0 3900.0		5700.0	
055START	-43.5 0.0	0.5	0.5	
055END	43.5 0.0	0.5	0.5	
NUMBER OF SECTIONS TO BE PROCESSED FROM MODEL 'THORNBROUGH GROUND MODEL' IS 19				
-CHAINAGE- /DISTANCE-	---SECTIONAL AREAS---		-INTERMEDIATE VOLUMES-	-ACCUMULATIVE VOLUMES-
	---CUT---	---FILL---	---CUT---	---FILL---
3900.000	0.000	-96.837		0.000 0.000
4000.000	0.000	-108.131	0.000	-10248.392
4100.000	0.000	-182.152	0.000	-14514.142
4200.000	0.000	-317.636	0.000	-24989.381
4300.000	0.000	-544.531	0.000	-43108.362
4400.000	0.000	-700.561	0.000	-62254.600
4500.000	0.000	-883.225	0.000	-79189.287
4600.000	0.000	-1140.644	0.000	-92860.277
4700.000	0.000	-1688.085	0.000	-155114.877
			0.000	-197781.386

4800.000	0.000	-2267.542	0.000	-246239.721	0.000	-674715.502
4900.000	0.000	-2657.252	0.000	-279823.217	0.000	-920955.222
5000.000	0.000	-2939.212	0.000	-307286.793	0.000	-1200778.440
5100.000	0.000	-3206.523	0.000	-334510.976	0.000	-1508065.233
5200.000	0.000	-3483.696	0.000	-358592.885	0.000	-1842576.209
5300.000	0.000	-3688.162	0.000	-379446.930	0.000	-2201169.094
5400.000	0.000	-3900.777	0.000	-397308.312	0.000	-2580616.024
5500.000	0.000	-4045.389	0.000	-405846.992	0.000	-2977924.336
5600.000	0.000	-4071.551	0.000	-400673.415	0.000	-3383771.327
5700.000	0.000	-3941.918			0.000	-3784444.742

CHAINAGE	LEFT OFFSET		RIGHT OFFSET	
3900.0	-45.67	FILL	45.67	FILL
4000.0	-45.32	FILL	46.53	FILL
4100.0	-46.45	FILL	48.47	FILL
4200.0	-50.37	FILL	50.37	FILL
4300.0	-54.60	FILL	54.60	FILL
4400.0	-57.03	FILL	58.48	FILL
4500.0	-59.46	FILL	61.46	FILL
4600.0	-62.50	FILL	65.89	FILL
4700.0	-70.33	FILL	74.33	FILL
4800.0	-76.76	FILL	82.76	FILL
4900.0	-81.79	FILL	86.72	FILL
5000.0	-86.62	FILL	89.62	FILL
5100.0	-90.05	FILL	92.06	FILL
5200.0	-92.48	FILL	96.58	FILL
5300.0	-94.82	FILL	98.69	FILL
5400.0	-97.59	FILL	100.59	FILL
5500.0	-99.16	FILL	99.16	FILL
5600.0	-99.41	FILL	98.41	FILL
5700.0	-98.33	FILL	98.33	FILL

999

## Minor option 054 Standard profile and existing sections

Calculate volumes between an existing set of cross sections (produced by major option SECTION) and a standard profile.

The set of sections to be used is referred to by a single character, and the model in which the sections are stored. Further explanation of cross section techniques can be found in major option SECTION.

Input

Graphic

IGVOLUT.DAT, VOL002, VOL007, VOL008

VOLUME minor options	Using exist cross sections	Define standard profile
Define system parameters	Reference string label	Start/end point (T)
Define linear units	Volume string label	Offset from ref. string
Define string masking	End Area string label	Level from ref. string
Volume environment	Section set label	Slope in cut
Using parallel sections	Start X / Y	Slope in fill
Using cross sections	Topsoil depth	
Auto standard profile	End X / Y	
Using exist cross sections	Hatching default (T)	
Define standard profile		
2 exist. cross sections		

◇ *The standard profile is set up using minor option 055 which automatically follows option 053. When the VOLUME 055 menu is first displayed you are prompted to define the start offset of the standard profile. VOLUME 055 will automatically prompt for the next offset. It will continue to prompt until you change the start/end point toggle to end.*

Linemode

Minor option 054

- \* Field 1 Reference string from which sections were taken.
- \* Field 2 The cross section set reference character in the first character position.
- Field 5 & 6 SPRD start
- Field 7 Topsoil depth.
- Field 8 & 9 SPRD end

The printout details the running volumes and the interface offsets similar to the 053 option.

Example

This is similar to the example for the 053 option but uses stored sections.

```
VOLUME, VOLUME TEST SECTIONS, VOLUME MODEL
054, M003, G, 5=3900.0, 8=5700.0
055, START, 4=-43.5, 0.0, 0.5, 0.5
055, END, 4=43.5, 0.0, 0.5, 0.5
999
```

## Minor option 055 Define standard profile

Define a standard profile for use in minor options 053 and 054.

A standard profile is defined by giving offset and level difference relative to a reference string in minor option 053 and 054. Each offset must be given in order from left (negative offsets) to right across the desired profile looking in the direction start point to end point. In addition, the first and last offsets have values for cut and fill slopes, which are used to extend the profile to meet the section through the model. Minor option 055 may have a minimum of 2 and a maximum of 20 offsets for each standard profile.

### Input

#### Graphic

IGVOLUT.DAT, VOL002, VOL008

VOLUME minor options	Define standard profile
Define system parameters	Start/end point (T)
Define linear units	Offset from ref. string
Define string masking	Level from ref. string
Volume environment	Slope in cut
Using parallel sections	Slope in fill
Using cross sections	
Auto standard profile	
Using exist. cross sections	
Define standard profile	
2 exist. cross sections	

- ◇ *When the VOLUME 055 menu is first displayed you are prompted to define the start offset of the standard profile. VOLUME 055 will automatically prompt for the next offset. It will continue to prompt until you change the start/end point toggle to be end.*

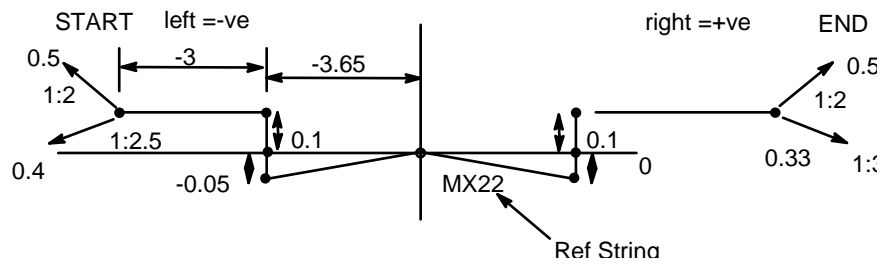
### Linemode

#### Minor option 055

- Field 1 Code START if first offset.  
Code END if last offset.
- \* Field 4 Code the offset value from the reference string (left hand offsets negative, options must be in order left to right).
- \* Field 5 Code the level difference from the reference string (negative value for a fall).

- Field 6 For START and END records only, code the required slope in cut (ie slope upwards) as a decimal fraction eg for a slope of 1 in 3, code 0.33.
- Field 7 For START and END records only, code the required slope in fill (ie slope downwards), as a decimal fraction.
- ◇ *The standard profile does not automatically pass through the reference string.*

**Example**



**Figure 9 - 20 Typical standard profile and coding**

```

055,START,4=-6.65,0.1,0.5,0.4
055,4=-3.65,0.1
055,4=-3.65,0.05
055,4=3.65,-0.05
055,4=3.65,0.1
055,END,4=6.65,0.1,0.5,0.33
999
    
```

**Minor option 056 Two existing cross sections**

Calculate volumes between two existing sets of section, produced by major option SECTION.

Both sets of sections must be contained within the same model, and must have been produced from identical points on the same reference string.

Input

Graphic

IGVOLUT.DAT, VOL002, VOL009

VOLUME minor options	2 exists cross sections
Define system parameters	Reference string label
Define linear units	Volume string label
Define string masking	End Area string label
Volume environment	Section set 1
Using parallel sections	Section set 2
Using cross sections	Start X/Y
Auto standard profile	Topsoil depth
Using exist. cross sections	End X/Y
Define standard profile	Hatching default (T)
2 exist cross sections	

Linemode

Minor option 056

- \* Field 1 Reference string label.  
If curve correction is on, this string must be a master alignment string.
- \* Field 2 Section set 1 prefix character.
- \* Field 3 Section set 2 prefix character.
- Field 5 & 6 SPRD start
- Field 7 Topsoil depth (metres)  
Depth reduced from section set specified in field 2.
- Field 8 & 9 SPRD end

Example

This example illustrates the use of two sets of stored sections between chainages 10.0 and 310.0 about the reference string MAST.

MOSS

VOLUME, SIMPLE DESIGN SECTIONS, SIMPLE DESIGN ROAD

VOLUME, SIMPLE DESIGN VOLUMES

056,MAST,G,R,,10,,0.1,310

999

MOSS

VOLUME SIMPLE DESIGN SECTIONS SIMPLE DESIGN ROAD

VOLUME SIMPLE DESIGN VOLUMES

056MASTG R 10 0.1 310

NUMBER OF SECTIONS WITH INITIAL LETTER 'G' IS 31

NUMBER OF SECTIONS WITH INITIAL LETTER 'R' IS 31

-CHAINAGE- -DISTANCE-	---SECTIONAL AREAS---		-INTERMEDIATE VOLUMES-		-ACCUMULATIVE VOLUMES-	
	(SQ. M.)		(CU. M.)		(CU. M.)	
	---CUT---	---FILL---	---CUT---	---FILL---	---CUT---	---FILL---
10.000	1.652	-0.801			0.000	0.000
20.000	1.396	-0.467	15.240	-6.340	15.240	-6.340
30.000	1.606	-0.778	15.008	-6.228	30.248	-12.568
40.000	1.447	-1.452	15.265	-11.153	45.513	-23.721
50.000	1.252	-1.762	13.496	-16.068	59.009	-39.789
60.000	1.099	-2.363	11.753	-20.621	70.762	-60.411
70.000	1.158	-2.785	11.286	-25.740	82.048	-86.151
80.000	1.323	-3.121	12.405	-29.533	94.453	-115.684
90.000	1.428	-3.653	13.752	-33.871	108.205	-149.555
100.000	1.423	-4.378	14.257	-40.157	122.461	-189.712
110.000	1.251	-4.892	13.372	-46.351	135.833	-236.063
120.000	1.061	-5.146	11.560	-50.191	147.393	-286.255
130.000	1.237	-4.786	11.492	-49.660	158.885	-335.915
140.000	1.238	-4.007	12.376	-43.963	171.261	-379.878
150.000	2.492	-3.093	18.647	-35.501	189.908	-415.379
160.000	1.214	-2.039	18.526	-25.662	208.434	-441.041
170.000	1.096	-1.135	11.548	-15.869	219.982	-456.910
180.000	1.142	-1.285	11.191	-12.096	231.173	-469.006
190.000	1.028	-1.948	10.853	-16.160	242.025	-485.167
200.000	0.724	-2.507	8.763	-22.272	250.789	-507.438
210.000	0.371	-3.088	5.474	-27.971	256.263	-535.410
220.000	0.510	-2.871	4.401	-29.792	260.665	-565.202
230.000	0.000	-11.828	2.548	-73.496	263.212	-638.698
240.000	0.000	-15.359	0.000	-135.935	263.212	-774.633
250.000	0.160	-19.291	0.799	-173.247	264.012	-947.880
260.000	0.000	-13.591	0.799	-164.409	264.811	-1112.288
270.000	0.000	-10.903	0.000	-122.468	264.811	-1234.757
280.000	0.000	-9.309	0.000	-101.057	264.811	-1335.814
290.000	0.000	-9.635	0.000	-94.718	264.811	-1430.532
300.000	0.000	-10.432	0.000	-100.335	264.811	-1530.867
310.000	0.000	-13.399	0.000	-119.156	264.811	-1650.023

999

W201 END OF INPUT DATA FILE REACHED



## Minor option 058    Models for VOLUME

### Input

#### Graphic

IGVOLUT.DAT, VOL001

Models for VOLUME
Existing/Sections model
Proposed/Reference model
Model to store volumes

- ◇ *In graphics mode the decision to store volumes information into a volume string can only be made on entry to major option VOLUME when the Models for VOLUME menu is displayed. If you enter a model name for model 3, storage of volumes information into a volume string will take place.*

#### Linemode

Mass Haul analyses are based on volume calculations which may be stored in special strings. The volume string is created on request, immediately after a volume calculation. Due to the special nature of the volume information the volume strings should be stored in a separate model, and for the purpose a third volume model may be specified.

The volume string is ten dimensional and is related to the reference string on which the volumes calculations are based. The first four dimensions are point coordinates (dimensions 1 and 2); level and chainage. Volumes are only stored at exact chainage interval multiples, and are only applicable after using minor options 052, 053, 054 and 056.

If a volume string is to be stored a second major option record VOLUME defining the model to store the string in must be coded.

The method of storing information in a string is to follow the chosen volume with a minor option 058.

- eg VOLUME, SECTIONS MODEL, REFERENCE MODEL  
VOLUME, VOLUMES MODEL
- 052 (volumes from 2 sets of sections and within a boundary)
- 058 (store the above calculated volumes in a volume string)
- 053 (volumes between a standard profile and sections)
- 058 (store the above volumes in a volume string)
- Minor option 058**
- Field 2 The label of the End Area string to be created.
- \* Field 3 The label of the volume string to be created.
- The first 3 string dimensions are those of the reference string from which the volumes have been calculated and the chainage interval defined. The fourth dimension is the chainage and the fifth and sixth are fill and cut volumes respectively.

# Mass haul analysis

Mass Haul analyses are a natural progression following the calculation of accurate earthworks quantities. The options provided in MOSS apply not only to linear schemes but can also include volumes defined inside boundaries within the overall project.

The volumes adjustment is provided to allow for:-

- Import and export of material.
- The removal of unsuitable material.
- Application of combined bulking and shrinkage factors.
- Different material types within cuttings.

The analysis may be considered as three phases:-

- The storage of volume quantities in a volume string for each volume calculation.
- The collecting together of a series of volume strings into a 'scheme volume string'.
- The Mass Haul analysis itself.

## Volume strings

If Mass Haul analysis is required then the calculation of volumes must be stored in a volume string. This volume string is generated within major option VOLUME at the time of running the volumes option and stored within a defined 'volumes' model. The volume string may only be generated when volumes have been calculated relative to a reference string and must start and end at an exact chainage multiple. There may be several volume strings contributing to an overall project.

## Scheme volume string

When several volume strings contribute to a project it is necessary to define the reference string for the project and associate each of the individual volume strings to it with the various corrections for additional overall earthworks. If there is only one previous volume string and no corrections this step is unnecessary.

The scheme volume string must start and end on an exact chainage multiple on the reference string, which must be a master alignment.

## Mass haul analysis

Once the scheme volume string is completed the Mass haul analysis may be carried out allowing for bulking and shrinkage of materials and the introduction of import and export quantities. The result of this stage will be tabular quantities, containing accumulated volume information.

Comprehensive graphic output may also be produced using major option DRAW.

### Multiple materials and rock

When it is required to carry out analyses for schemes which involve several materials and/or rock the following method is used.

The proportions of each material within a chainage range are specified together with opposite bulking/shrinkage factors for each. As quantities of each of the various materials, including rock, are no likely to be highly accurate at the tender stage this approach often allows for realistic estimates to be made base on straightforward modelling.

### Graphic output

Facilities are available within major option DRAW to produce Mass Haul diagrams. In particular various macro command options may be created for the drawing of curves for each of the contributing materials.

## Application of major option VOLUME to Mass Haul

The mass haul analysis is based on the results of the volume calculations which are stored in volume strings. The volume string is created on request, immediately after a volume calculation option and is stored in a model specially created for this purpose. For this purpose a third volume model may be specified.

The volume string is ten dimensional allowing for up to 5 strata volume values to be stored. The ten dimensions are:-

#### Dimension

1	Easting (X)
2	Northing (Y)
3	Elevation (Z)
4	Chainage (C)
5	Fill volume
6	Cut volume for upper stratum 1.
7	Cut volume for upper stratum layer 2.
8	Cut volume for upper stratum layer 3.
9	Cut volume for upper stratum layer 4.
10	Cut volume for upper stratum layer 5.

Valid volume strings are generated following minor options 052; 053; 054 and 056 ie following options which are related to a reference string. Other volumes options provide a total volume which may be distributed over a defined length of the scheme volume string.

Multi-strata analyses are not yet implemented and consequently dimensions 7-10 are not used other than being set to zero.

The storage of volumes is optional and is requested with an additional minor option 058. It is stored in a third volume model so as to keep it separate from other design or surface information.

## Mass haul analysis

The stored volume strings provide the basic data for the mass haul analysis. Different analyses may be produced by changing the values of variables and each analysis may be stored in a separate 'mass' string.

The volume option can produce the volume string from each volume calculation but the mass haul analysis may be carried out on a combination of volume strings, additional volumes and corrections. This is achieved by building a 'scheme' volume string on which the mass haul analysis may operate. If one volume string alone is being considered then it is unnecessary to build a 'scheme' volume string.

### Stage 1

Produce volume string containing quantities related to chainage.

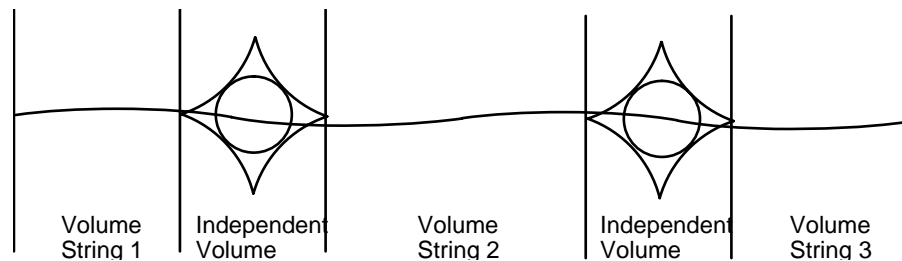


Figure 9 - 21 Volume string - quantities related to chainage

### Stage 2

Create scheme volume string including all earthworks quantities and corrections.

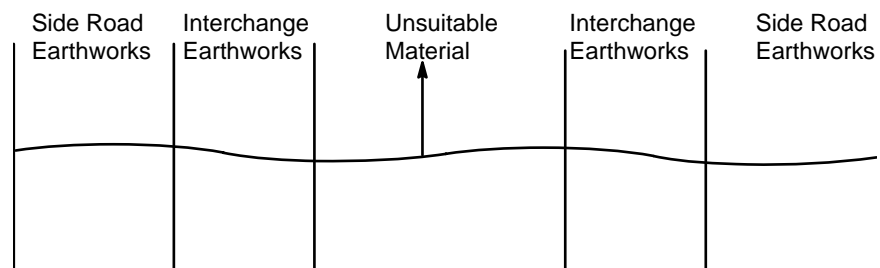
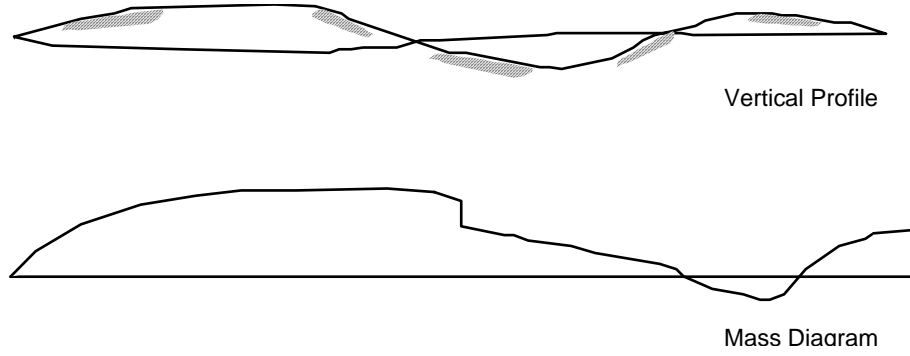


Figure 9 - 22 Volume string - earthwork quantities

### Stage 3

Production of Mass Haul allowing for bulking/shrinkage and import/export.



**Figure 9 - 23 Relationship between vertical profile and mass diagram**

## Major option HAUL

Major option HAUL is only available in linemode.

The minor options provided within HAUL are:-

- 070 Define a scheme volume string.
- 071
  - a) Define the constituent volume strings of the scheme volume string.
  - b) Define bulk quantities for inclusion in the scheme volume string.
- 072 Define a mass haul string.
- 073 Specify adjustment variables for cutting materials.
- 074 Specify adjustment variables for import/export and unsuitable materials.
- 075 Carry out a mass haul analysis.

The mass haul string is ten dimensional allowing for up to five strata mass values to be stored. The ten dimensions are:-

Dimension

- 1 Easting (X)
- 2 Northing (Y)
- 3 Level (Z)
- 4 Chainage (C)
- 5 Balance
- 6 Accumulated Cut for stratum 1.
- 7 Accumulated Cut for stratum 2.
- 8 Accumulated Cut for stratum 3.
- 9 Accumulated Cut for stratum 4.
- 10 Accumulated Cut for stratum 5.

## Model for HAUL

- Model 1 The model containing the volume string and the model in which scheme volume strings and mass haul analysis strings are stored.
- Model 2 The model containing any reference string if not contained within model 1.

## Global minor options

The global minor options 000, 017, 019, 900 and 999 may be used with HAUL.

## Minor option 070 Define a scheme volume string

This minor option sets up a scheme volume string about a reference alignment, with points at a specified chainage interval. The string dimensions which will hold volumes are set to zero. Each option 070 is followed by one or a series of 071 options which insert volume information into the string dimensions. The 070 defines the extent and range of the options 071 to follow.

### Input

#### Minor option 070

- \* Field 1 Reference string label
- \* Field 3 Scheme volume string to be created
- \* Field 4 Chainage interval
- Field 5 & 6 SPRD start
- Field 8 & 9 SPRD end

◇ *The start and end points must be at exact chainage multiples.*

## Minor option 071 Include volumes in scheme volume string

This minor option puts volumes into the appropriate dimensions of the scheme volume string by one of two methods:-

- a) Include an individual volume string.
- b) Include bulk quantities.

An individual volume string can only be included if it has been generated about an alignment collinear with the reference alignment and at the same chainage interval as that specified on the previous 070 option.

### Input

#### Minor option 071

##### Include an individual volume string

- \* Field 2 Individual volume string
- Field 5 & 6 SPRD start
- Field 8 & 9 SPRD end

◇ *The volume string specified in Field 2 must have been created from sections at regular intervals and with reference to the reference string used by minor option 070 'Define a scheme volume string'.*

##### Include a bulk quantity

#### Minor option 071

- Field 4 Code 1.0 to indicate single point identifier



- Field 5 & 6    SPRD start
- \* Field 7        Cut volume
- Field 8 & 9    SPRD end
- \* Field 10       Fill volume

As each 071 option is processed the volume information at a point is added to any information already held. The volumes input against the first point are not transferred, as they relate to the chainage interval preceding the start point. No duplication will then result if a chainage or point is used as the end point of one 071 option and the start point of another 071 option.

This also applies to bulk quantity input - the volumes are distributed evenly between the 2nd point and the specified end point.

- ◇ *Input at a single point is achieved by coding field 4. This means that fields 8 and 9 must be left blank.*
- ◇ *If SPRD are omitted the start and/or end points are taken as those specified in the preceding 070 option. (The default SPRD would normally apply to the full extent of the reference string).*
- ◇ *Cut volumes in field 7 will always be converted to a positive value.*
- ◇ *Fill volumes in field 10 will always be converted to a negative value.*

The final minor option of a range of option 071 should be totally blank apart from the minor option code. This indicates that all supporting details have been defined and the scheme volume string may be generated.

### Example

```
HAUL, THORNBROUGH VOLUMES, NEW THORNBROUGH
070, M003, , VM03, 50
071, M003, V061, VM03, 5=3900, 8=5400
071, M003, , VM03, 1.0, 5400, , 10000
071, M003, VL2, VM03, 5=5400, 8=5700
071
```

## Minor option 072    Mass haul analysis

Minor option 072 produces the mass haul analysis from the scheme volume string or an individual volume string. Complementary 073 and 074 options may be used to allow for bulking/shrinkage factors, additional material types and import/export of material.

The analysis may apply to all or any part of the scheme volume string.

### Input

#### Minor option 072

- \* Field 1        Reference string
- \* Field 2        Scheme volume string
- \* Field 3        Mass string

Field 4 Combined bulking/shrinkage factor (applied to material 1)  
(default value 1.0)

Field 5 & 6 SPRD start

Field 8 & 9 SPRD end

The start and end points identify the extent of the mass analysis, allowing different sections of the scheme to be analysed. Each section could represent the separate contracts within an overall project, or the investigation of local alternatives within a contract for accommodating rivers or railways which may form haulage barriers.

If SPRD are omitted the start and/or end of the scheme volume string are assumed to apply and not the reference string as would normally be the case.

The mass haul analysis can be produced with only the 072 option if there are no supporting 073 and 074 minor options. In this instance an option 075 invokes the analysis itself.

### Example

```
HAUL, THORNBROUGH VOLUMES, NEW THORNBROUGH  
072, M003, VM03, HM03, 1.2, 3900, 8=5700  
075
```

## Minor option 073 Bulking/shrinkage factors

Often there is insufficient geotechnical information to generate any strata models although the existence of different material types is known. The feature is available whereby the quantity of cut material of upper stratum may be distributed across the other strata by defining chainage extend, combined bulking/shrinkage factors and proportions.

A similar situation applies in the single stratum case where only total volumes are available but the bulking/shrinkage factors vary within different cuttings.

The 073 option allows the introduction of additional material types by specifying material types 2 - 5 as a proportion of the total volume of cut, in addition to specifying combined bulking/shrinkage factors as appropriate.

Each 073 option may apply to any part of or all to the mass string. Only cut volumes are considered. The sum of the proportions, at any point, expressed as decimals, cannot exceed 1.0. If the sum is less than 1.0 then the residual will be material type 1.

**Input****Minor option 073**

- \* Field 3      Material identifier (2 - 5)
- Field 4      Combined bulking/shrinkage factor (default 1.0)
- \* Field 5 & 6   SPRD start
- Field 7      Proportion of material, expressed as a decimal
- \* Field 8 & 9   SPRD end
- ◇ *This option must be preceded by an 072 option, which defines the reference and volume strings.*

If a combined bulking/shrinkage factor outside the range 0.4 - 1.6 is specified a warning is given but all positive values are accepted.

Default SPRD apply to the ends of the mass string, not the reference string.

**Minor option 074 Mass haul adjustment (Import and Export)**

The 074 option allows adjustment of the quantities to allow for import or export of the various materials. A 'stepped profile' showing the adjustment at an instantaneous point, is not available. The adjustment is applied over the chainage interval after the point specified. If a non-exact point is specified the adjustment is applied over the chainages interval containing the non-exact point.

Import and export cannot be specified at the same chainage point on the same 074 record.

**Minor option 074    Import    adjustment**

A combined bulking/shrinkage factor may be specified for the material and the adjusted volume added to the balance.

**Input****Minor option 074**

- Field 3      Material identifier (1 - 5)
- Field 4      Combined bulking/Shrinkage factor (default 1.0)
- Field 8 & 9   SPRD end
- \* Field 10     Import quantity
- ◇ *If field 4 is used, fields 8 and 9 must also contain information.*
- ◇ *This option must be preceded by an 072 option, which defines the reference and volume strings.*

## Minor option 074    Export adjustment

The export quantity is specified as a volume to be deducted from the quantities for a defined material type in the volume string. The output details the quantities after bulking/shrinkage and the appropriate combined bulking/shrinkage factor for the material is assumed the same as specified on the 072 or 073 options.

### Input

#### Minor option 074

Field 3        Material identifier (1 - 5)

Field 5 & 6    SPRD start

\* Field 7        Export quantity

◇ *If field 4 is used, fields 8 and 9 must also contain information.*

◇ *This option must be preceded by an 072 option, which defines the reference and volume strings.*

## Minor option 075    Carry out mass haul analysis

### Input data

#### Minor option 075

Leave all fields blank

### Example

```
HAUL, THORNBROUGH VOLUMES, NEW THORNBROUGH  
072, M003, VM03, VV03, 0.8, 3900, 8=5700.0  
075  
999
```

# HAUL macros

Major option DRAW provides the facilities to produce comprehensive mass haul diagrams. However a rapid means of graphically presenting an analysis is often required and a macro has been created for this purpose. The basic drawing using MASSDRAW may be supplemented using macro LONGLINE and the example illustrates this.

## Macro MASSDRAW

### Example

```
900 , MASSDRAW
HS=500 , VS=50000 , LB=M001 , LR=M001
```

Attributes are assigned similarly to macro PLANDRAW and again if they are not relevant or of no interest then they may be ignored.

In the following                    PV implies Any Positive Value  
     CV implies Any Characters

### Input

#### Sheet details

Code	Description	Alternatives	Default
FD	First drawing if there is overplotting	"	-
OD	Subsequent drawing if there is overplotting	"	-
TR	Truncation	NOTR TRUN	NOTR
SL	Sheet length	PV	120 (cms)
SW	Sheet width	PV	68 (cms)
FR	Frame	FRAM NOFR	NOFR
ML	Left margin	PV	1.0
MB	Bottom margin	PV	1.0
MT	Top margin	PV	1.0
MR	Right margin	PV	1.0
PA	Paged or non-paged drawing	NOPA PAGE	NOPA
XO	Offset to be added to the left of the leftmost point	PV	0.0

- ◇ *If SL or SW is defined then FD = " must also be requested.*
- ◇ *If SL is assigned but not SW an A size sheet is being specified, but if SW is assigned but not SL then a B size sheet is being specified.*

### Drawing details

Code	Description	Alternatives	Default
YO	Offset to be added to the lowest point	PV	0.0
LP	Box in which the parameter is to be annotated	PV	1
LD	Box in which the distance parameter is to be annotated	PV	2
HP	Box description of the level parameter	C = chainage D = distance E = existing P = proposed L = level * = whatever is written in TP	*
TP	Box description if HP=*	CV	-
HD	Box description of the distance parameter	C = chainage D = distance E = existing P = proposed L = level * = whatever is written in TD	D
TD	Box description if HD=*	CV	
HS	Horizontal scale	PV	
VS	Vertical scale	PV	
LC	String colour	CV	BLACK
TC	Text colour	CV	BLACK

### Model details

Code	Description	Alternatives	Default
LR	Reference string	CV	
LB	Section string	CV	
XS	Start point on reference string (SPRD)	PV	First point
YS		PV	
XE	End point on reference string (SPRD)	PV	Last point
YE		PV	
DN	Dimension to be drawn		

### Explanatory Notes

1. FD and OD are normally used when producing composite drawings. The assignment FD=" indicates to the macro that this is the first drawing and OD=" indicates it is a subsequent drawing.
2. The only essential variables which need to be assigned in the macro are HS, VS and LB and LR ie the horizontal and vertical scales, the string label being drawn and the reference string on which it is based.
3. When superimposing long section profiles it may well occur that the first section is defined in LONGDRAW with the boxes being in positions 1 and 4 say with subsequent sections being defined with LONGLINE to infill positions 2 and 3.

## Macro LONGLINE

### Drawing details

Code	Description	Alternatives	Default
LN	Box in which the 'level' parameter is to be annotated.	PV	-
HN	Box description to the 'level' parameter	C = chainage D = distance E = existing P = proposed L = level * = whatever is written in TN	L
TN	Box description of HN=*	CV	-
LC	String colour	CV	BLACK
TC	Text colour	CV	BLACK

### Model details

Code	Description	Alternatives	Default
LR	Reference string	CV	
LB	String to be drawn	CV	
XS	Start point on reference string (SPRD)	PV	First point
YS		PV	
XE	End point on reference string (SPRD)	PV	Last point
YE		PV	
DN	Dimension to be drawn	PV	3

### Example

#### Input

```

DELETE, GRINTVOL
CREATE, GRINTVOL
VOLUME, INTERFACE SECTIONS, INTER 1C
VOLUME, GRINTVOL
056, MAST, G, R
058, 3=V001
999
HAUL, GRINTVOL, INTER 1C
    CREATE MASS STRING HPR3
072, MAST, V001, HPR3, 5=0, 8=550
    THE VOLUME STRING V001 CONTAINS ONLY ONE MATERIAL.
    DIFFERENT MATERIALS MAY BE ESTIMATED WITH THE 073
OPTION
    BY SPECIFYING THE REQUIRED MATERIAL PROPORTIONS AND
    ASSOCIATED COMBINED BULKING AND SHRINKING FACTORS
073, 3=2, 1.5, 20, 7=0.2, 550
073, 3=3, 1.2, 20, 7=0.3, 550
073, 3=4, 1.5, 20, 7=0.1, 550
    
```

```

073,3=5,1.6,20,7=0.2,550
  EXPORT QUANTITIES
074,3=2,5=80,,10
074,3=3,5=120,,18
074,3=4,5=360,,35
074,3=5,5=480,,45
  IMPORT QUANTITIES
074,3=2,4=1.5,8=60,,1000
074,3=3,4=1.2,8=100,,1000
074,3=4,4=1.0,8=350,,1000
074,3=5,4=1.1,8=420,,1000
075
999
  
```

### Output

```

VOLUME  INTERFACE SECTIONS          INTER 1C
VOLUME  GRINTVOL
056MASTG  R
NUMBER OF SECTIONS WITH INITIAL LETTER 'G' IS  56
NUMBER OF SECTIONS WITH INITIAL LETTER 'R' IS  56

-CHAINAGE-    ---SECTIONAL AREAS---    -INTERMEDIATE VOLUMES-    -ACCUMULATIVE VOLUMES-
-DISTANCE-    ---CUT---    ---FILL---    ---CUT---    ---FILL---
0.000          0.000    -49.808          0.000    -491.807          0.000    0.000
10.000         0.000    -48.553          0.000    -479.257          0.000   -491.807
20.000         0.000    -47.298          0.000    -466.707          0.000   -971.065
30.000         0.000    -46.043          0.000    -454.157          0.000  -1437.772
40.000         0.000    -44.788          0.000    -454.157          0.000  -1891.930
50.000         2.548    -27.076          12.738    -359.321          12.738  -2251.251
60.000         3.642    -22.108          30.948    -245.919          43.686  -2497.170
70.000         3.889    -18.441          37.654    -202.742          81.340  -2699.912
80.000         4.261    -16.884          40.746    -176.622          122.086 -2876.534
90.000         4.750    -16.099          45.054    -164.911          167.140 -3041.444
100.000        0.000    -48.002          23.750    -320.505          190.891 -3361.949
  etc
470.000        20.296    -1.279          202.959    -12.793          7624.763 -6402.260
480.000        20.296    -1.279          202.959    -12.793          7827.723 -6415.053
490.000        20.296    -1.279          202.959    -12.793          8030.682 -6427.846
500.000        20.296    -1.279          202.959    -12.793          8233.641 -6440.639
510.000        45.372     0.000          328.338     -6.397          8561.980 -6447.036
520.000        46.627     0.000          459.992     0.000          9021.972 -6447.036
530.000        47.882     0.000          472.542     0.000          9494.514 -6447.036
540.000        49.137     0.000          485.092     0.000          9979.607 -6447.036
550.000        50.392     0.000          497.642     0.000         10477.249 -6447.036
058          V001
VOLUME STRING 'V001'  - REFERENCE STRING LABEL 'MAST'

--POINT--  -CHAINAGE-  ---FILL---  ---CUT---
  1          0.000    0.000    0.000
  2         10.000  -491.807    0.000
  3         20.000  -479.257    0.000
  4         30.000  -466.707    0.000
  5         40.000  -454.157    0.000
  6         50.000  -359.321   12.738
  7         60.000  -245.919   30.948
  8         70.000  -202.742   37.654
  9         80.000  -176.622   40.746
 10        90.000  -164.911   45.054
 11       100.000  -320.505   23.750
  etc
 48       470.000  -12.793   202.959
  
```



49	480.000	-12.793	202.959					
50	490.000	-12.793	202.959					
51	500.000	-12.793	202.959					
52	510.000	-6.397	328.338					
53	520.000	0.000	459.992					
54	530.000	0.000	472.542					
55	540.000	0.000	485.092					
56	550.000	0.000	497.642					
999								
HAUL	GRINTVOL		INTER 1C					
072MASTV001HPR3		0		550				
073	2	1.5	20	0.2	550			
073	3	1.2	20	0.3	550			
073	4	1.5	20	0.1	550			
073	5	1.6	20	0.2	550			
074	2		80		10			
074	3		120		18			
074	4		360		35			
074	5		480		45			
074	2	1.5			60	1000		
074	3	1.2			100	1000		
074	4	1.0			350	1000		
074	5	1.1			420	1000		
075								
MASS STRING 'HPR3'		-	REFERENCE STRING LABEL 'MAST'					
--POINT--	-CHAINAGE-	ACCUMULATED	---CUT1---	---CUT2---	---CUT3---	---CUT4---	---CUT5---	
		--VOLUME--						
1	0.000	0.000	0.000	0.000	0.000	0.000	0.000	
2	10.000	-491.807	0.000	0.000	0.000	0.000	0.000	
3	20.000	-971.065	0.000	0.000	0.000	0.000	0.000	
4	30.000	-1437.772	0.000	0.000	0.000	0.000	0.000	
5	40.000	-1891.930	0.000	0.000	0.000	0.000	0.000	
6	50.000	-2234.310	2.548	3.821	4.586	1.911	4.076	
7	60.000	-2439.067	8.737	13.106	15.727	6.553	13.980	
8	70.000	-1091.730	16.268	1524.402	29.282	12.201	26.029	
9	80.000	-1214.159	24.417	1536.626	43.951	18.313	39.068	
10	90.000	-1329.148	33.428	1540.142	60.170	25.071	53.485	
11	100.000	-1618.065	38.178	1547.267	68.721	28.634	61.085	
etc								
48	470.000	8475.675	1524.953	3777.429	3926.915	2108.715	3539.924	
49	480.000	8732.818	1565.545	3838.317	3999.980	2139.158	3604.871	
50	490.000	8944.961	1606.136	3899.205	4073.046	2169.602	3624.818	
51	500.000	9202.104	1646.728	3960.092	4146.111	2200.046	3689.765	
52	510.000	9632.397	1712.396	4058.594	4264.313	2249.297	3794.834	
53	520.000	10244.187	1804.394	4196.592	4429.910	2318.296	3942.031	
54	530.000	10872.668	1898.903	4338.354	4600.025	2389.177	4093.245	
55	540.000	11517.841	1995.921	4483.882	4774.658	2461.941	4248.474	
56	550.000	12179.706	2095.450	4633.175	4953.810	2536.587	4407.720	
999								

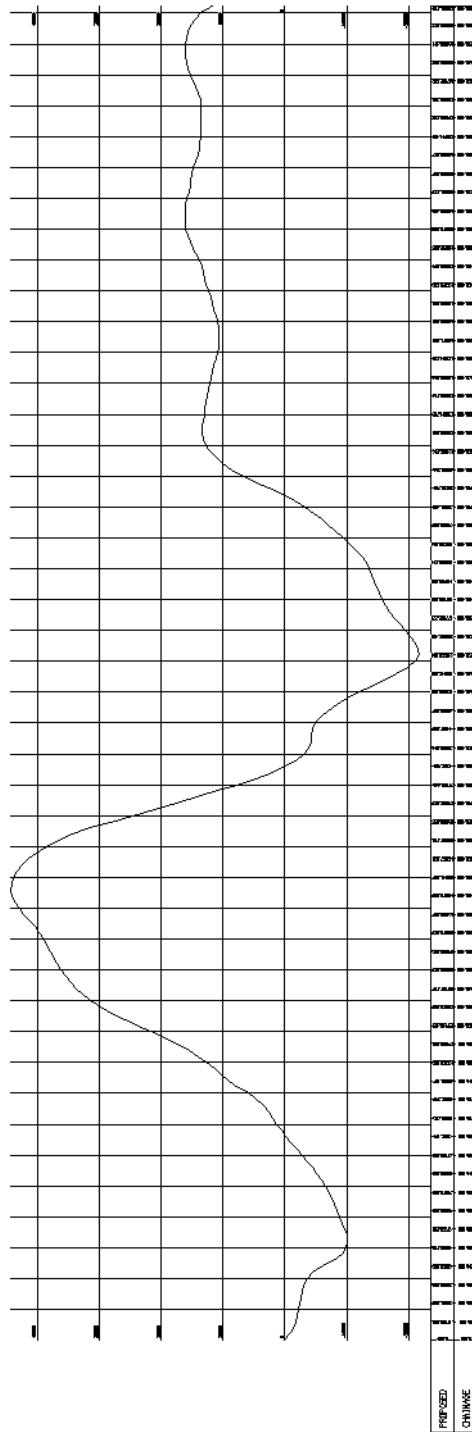


Figure 9 - 24 Example of Mass Haul diagram

# Chapter 10 Analysis by triangulation

## Analysis by triangulation

### Introduction

MOSS stores information in strings which are used to define surface models representing ground surfaces as recorded by aerial or ground survey, proposed works, geological models, etc. The accuracy to which the surface is recorded both in plan position and level depends upon the model content. However, although the model is adequately defined by a high saturation of strings and points which discretely describe the actual surface, no specified relationship exist between strings.

For many applications string relationships are unnecessary and information is extracted by a thorough geographic search, for example the production of interface strings. There are, however, applications such as contouring which require a knowledge of the model surface. It is, therefore, necessary to create the surface in a form that will allow these functions to operate.

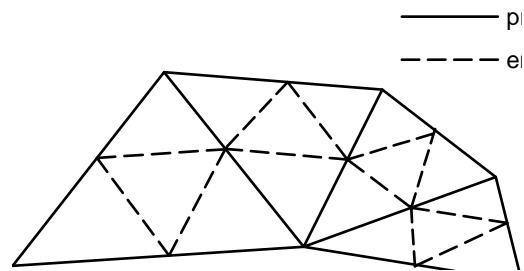
The most appropriate form of surface definition is considered to be formed of triangular plates which can be created from the recorded string and point information. A fundamental property of the MOSS concept is that because the strings define the surface, each string link can be considered as an edge of a surface triangle. The algorithms that have been developed ensure the efficient creation of the most appropriate triangles based on their plan relationship, ignoring level differences, except to avoid production of triangles with equal levels at all three vertices. These surface triangles are generated automatically by the major option TRIANGLE and are retained in such a form that access can be made from any triangle to its neighbours. The triangular mosaic may then be treated as a complete and continuous surface.

### Isopachyte analysis

Isopachyte analysis is an important extension to the theory of representing surfaces by a triangular mosaic. Rather than triangulating one surface only and then contouring it, two surfaces (ie two models) may be independently triangulated and the differences between them derived. The differences may themselves be analysed, with the result that the interface between two surfaces and also volumes may be accurately assessed. The method can be particularly appropriate for spoil heap analysis, open cast mining, or interchange design, where traditional sectioning techniques are less accurate.

### Smooth surface analysis

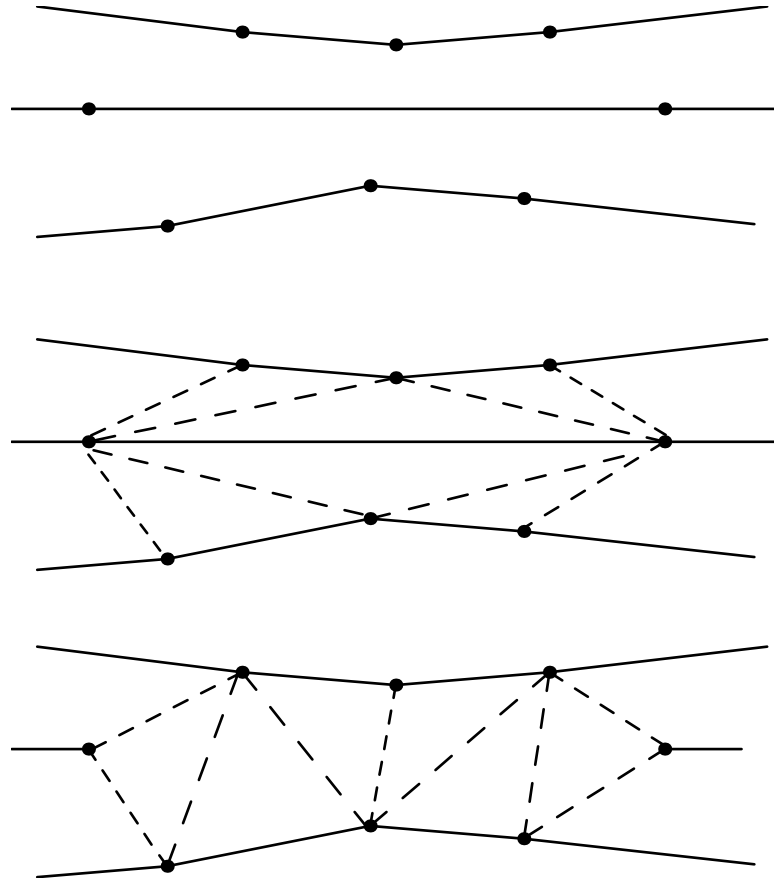
The initial or primary triangulation will faithfully reflect the data as a mosaic of planar triangles, but in areas of sparse data the resultant contours may not be sufficiently smooth for cartographic purposes. The primary surface may be enhanced by dividing each primary triangle into a number of smaller triangles whose vertices lie on a higher order surface than a plane. This subdivision accommodates the change in slope between adjacent triangles, provided the boundary between adjacent triangles is not part of a feature string, and the contours which are traced through the secondary triangulation reflect this continuity.



**Figure 10 - 1 Example primary and enhanced triangulations**

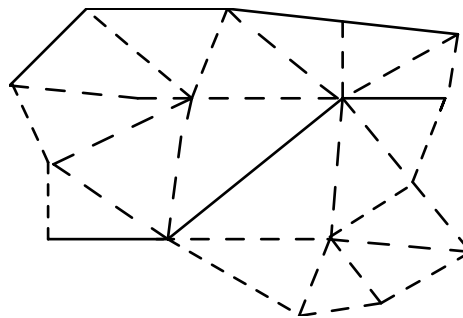
### Principles of surface triangulation

All the available model information is used to form a network of triangles. The most appropriate triangles selected by the algorithm can be described as being the most equiangular set of triangles satisfying the model content. The MOSS concept of defining surfaces and features as a series of strings requires that the string links must be maintained as sides of the triangles for the algorithm to guarantee an accurate representation of all the features.

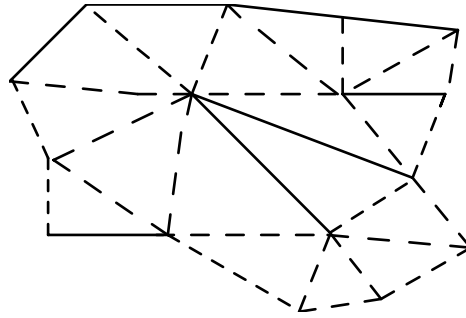


**Figure 10 - 2 Example - Triangulation maintaining string links**

The only strings that do not have their string links maintained as sides of triangles are P-strings as they normally represent random points and not features of the surface. The surface to be triangulated may be partially or completely represented by P-strings.



**Figure 10 - 3 Partial representation of the surface by P-strings**



**Figure 10 - 4 Complete representation of the surface by P-strings**

Links between discontinuities, null level points and the points adjacent to the null level points are also ignored. Any strings not considered suitable for inclusion within the triangulated surface can be omitted with the mask facility. The mask facility also allows strings to be interpreted as 'P' strings for triangulation purposes.

### Special conditions

There are certain situations where it is impossible for the triangulating algorithm to resolve the string information due to conflict in the recorded data. The conflicting circumstances and the assumptions made by the algorithm are as follows:-

1. intersecting string links.  
Both links are maintained by adding the intersection point to the triangulation. If the level at the intersection on one link is different to that on the other link, the first encountered level is taken.
2. duplicate point - different levels.  
The second point is replaced by the original point and all links are maintained.
3. duplicate link.  
This is a special case of duplicate points and the first link encountered is accepted.

A warning message may be given providing the coordinates of the points involved. These points should be checked for the possibility of error in the model content.

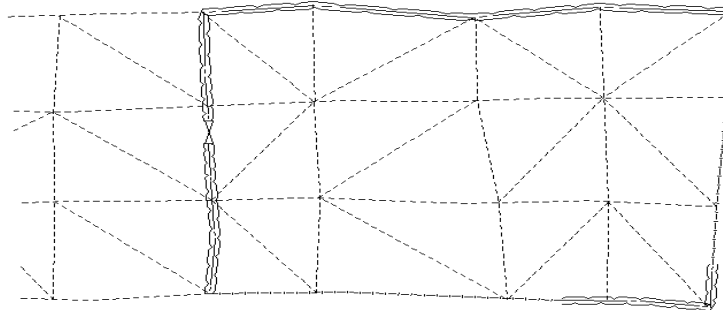
### Definition of area

Either the whole area can be triangulated or only a part may be triangulated by trimming to a boundary.

Points are only accepted if they lie within the common area or exist on the boundary. Points of intersection of strings with the boundary are included to improve the accuracy of low content models. If the boundary string is in the model the string links will be included.

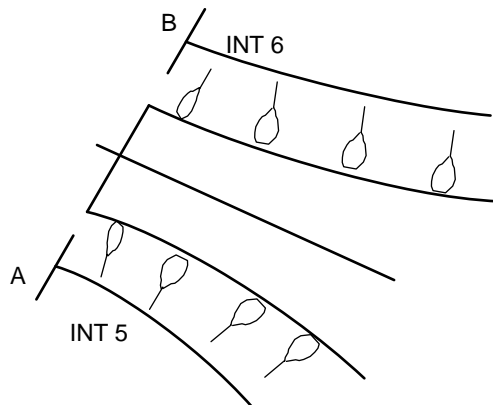
Defining the area by a boundary string created from existing features will often prove very practical because it naturally allows continuity of triangles between adjacent areas (although any links crossing the boundary will be

ignored). This method permits the sub-division of a large area into smaller areas for contouring. Such an example is in ground surveying where these boundaries could be formed from natural fence or hedge links around a group of fields.



**Figure 10 - 5 Example - definition of area for triangulation**

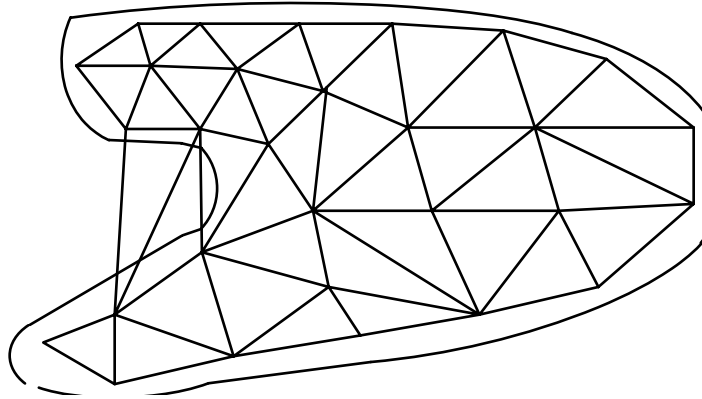
The boundary strings will duplicate existing features and may be in a separate model or masked out for the purpose of triangulation. If the boundaries are included the method allows for coincident links but the boundary must follow the actual ground surface. This is illustrated in Figure 10 - 6.



**Figure 10 - 6 Example - boundary for triangulation**

The link AB joining string INT5 to INT6 must be the road section A-B if the boundary is included in the model.

It is important to appreciate that the boundary string is only used to determine which points are to be included in the triangulation process. No attempt is made by the triangulation algorithm to ensure that the area within the boundary is completely covered by triangles or that triangles do not extend beyond the boundary.



**Figure 10 - 7 Example - boundary for triangulation**

### Restricting the extent of the triangulation

The triangular mosaic generated is convex in shape but because of the model content some of the triangle facets on the edge of the system may be quite meaningless. This is particularly noticeable when the area under consideration is concave, as can happen when contouring within a boundary. In Figure 10 - 7 the two triangles shown as dashed lines show how 'invalid' triangles can occur. One of two alternative methods may be chosen to restrict the triangulation to only those relevant. A triangle is simply flagged as being invalid by assigning null levels to each of its vertices.

#### Trimming method A (SHRINK)

All external triangles containing null levels are ignored. If an adjacent triangle to a null triangle has:

- i) a subtended internal angle greater than  $90^\circ$  and
- ii) the common edge is not a string link

then this triangle is considered a null triangle and is also ignored. Where a triangulation within a boundary has been requested any triangles whose centroid lies within the boundary is accepted as being a valid triangle.

This method is successful in ensuring that contours are omitted from undefined concave areas but it can mean that some valid triangles are cancelled. If a boundary string is used to select points this latter anomaly can result in the area not being fully covered and false plan and slope areas may be calculated. The method is very effective with survey data where it is not easy to define a boundary.

#### Trimming method B (ALL)

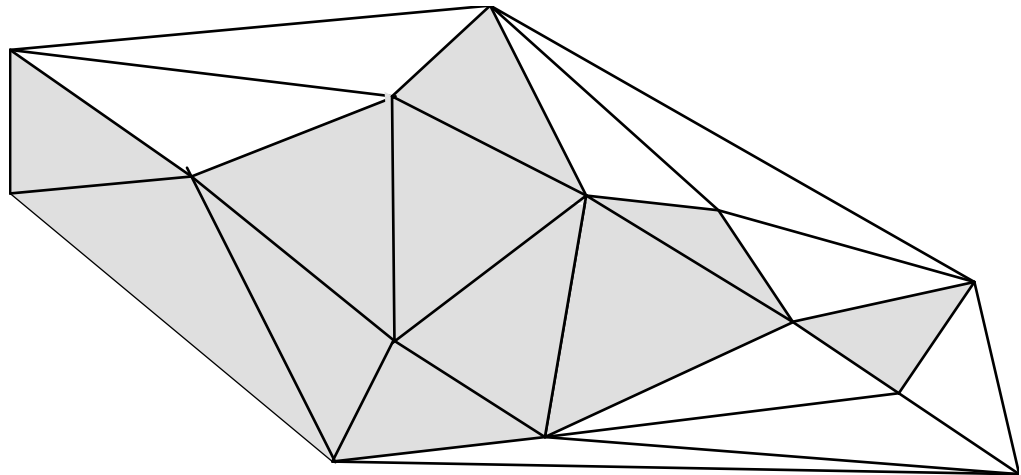
A more restrictive trimming method includes the same criteria but will not cancel a triangle if any of its sides is a string link. The added criteria is necessary to maintain a large enough triangulation for isopachyte analysis. This method, like method A, also checks that when a boundary is defined, the centroid of each triangle lies within the boundary.



By default the second trimming method is used but you may choose to use method A if necessary.

Figure 10 - 7 illustrates an example of the boundary condition being violated. However, in this case the boundary points have not been included therefore total coverage of the boundary is impossible. The example also illustrates that triangles may extend outside the boundary where the boundary is concave.

For the purposes of contouring and perspectives the fact that the boundary may not be completely covered can be in practice, of little consequence. It has been found that the extent of the triangulation can be foreseen and the creation and the inclusion of a boundary string is unwarranted in most cases. To predict the extent of the triangulation is to imagine the model contents triangulated to form a completely convex area then to remove from the edge of the area those triangles that have a non-string link outer edge and an obtuse angle subtending that outer edge.

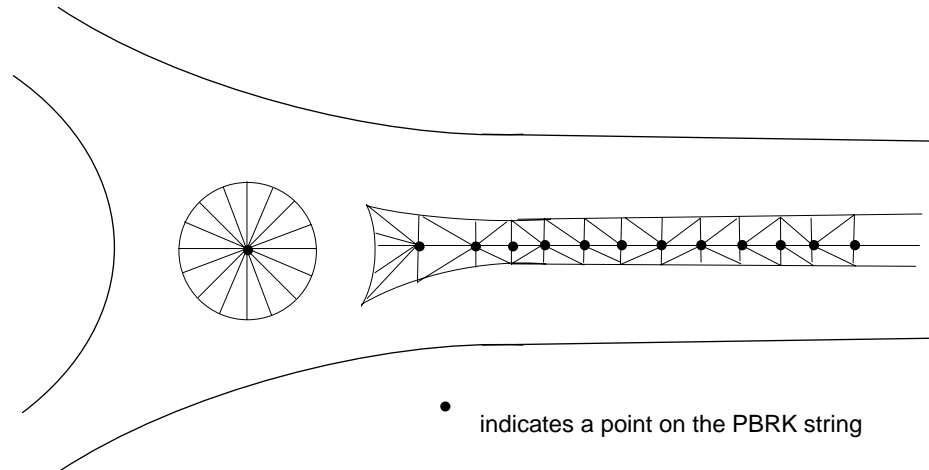


**Figure 10 - 8 Example - trimming method B**

### Triangle exclusion

Triangles can be excluded from an area of a model by the use of null level points, stored in a special string with the label PBRK. Normally, null level points are ignored during the building of the triangulation, but the points of the PBRK string are included in the calculation process. Any resulting triangles which have a null level at a vertex are excluded for the purpose of subsequent analysis of contours, flow arrows etc.

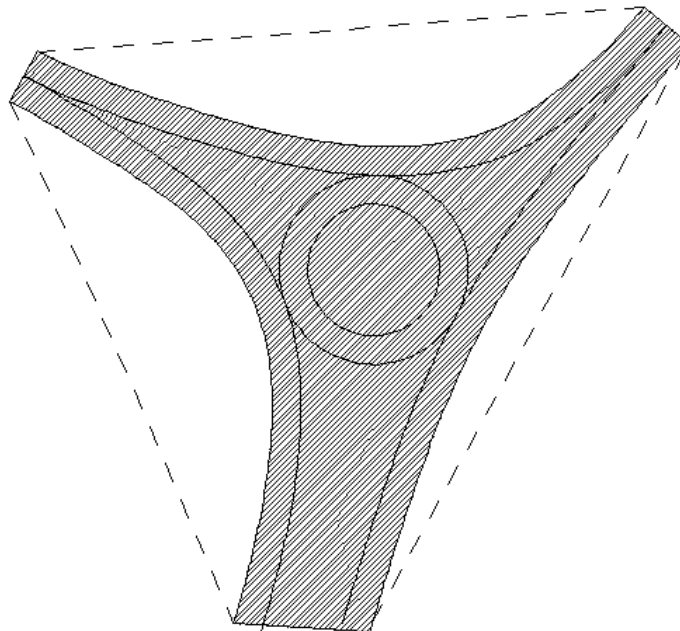
Only triangles with at least one null level point are cancelled. The centre of roundabouts can be cancelled by the inclusion of a single null level point near the central point. A central reservation along a carriageway can be cancelled by adding a series of null level points at a spacing similar to the carriageway edges. The spacing must be similar because the null level points being derived from a P-string do not form triangle edges automatically. Figure 10 - 9 shows the cancelled triangles in a typical situation.



**Figure 10 - 9 Excluding triangles**

**A general warning with triangulation**

Often section strings from both road and ground models are stored in the same section model. If this model is triangulated without proper care being taken to mask out one set of section strings representing one surface the resulting triangulation will be quite arbitrary. Normally this will result in an obviously incorrect surface mosaic.



**Figure 10 - 10 Example - area of acceptable triangulation**

In the above drawings the shaded area indicates that covered by acceptable triangles.

### Isopachyte analysis method

The method used to automatically produce isopachs relies on the triangulation of each surface to ensure all the surface features are considered. Two methods exist for the creation of an isopachyte triangulation.

#### Full method

- Both models are triangulated.
- Each vertex on the first triangulation is compared with the second triangulation to obtain a level difference.
- Each vertex on the second triangulation is compared with the first triangulation to obtain a level difference. Points of intersection between the triangulations are also considered.
- Both sets of level difference strings are combined and triangulated. This ensures that all angular features from both models are included in the analysis.
- Isopach contours or volume calculations are produced.

This method is very accurate but time-consuming for larger models.

#### Simple method

- Both models are triangulated.
- Each string point in the first string model is compared with the second triangulation to obtain a level difference.
- Each string point in the second string model is compared with the first triangulation to obtain a level difference.
- Both sets of level difference strings are combined and triangulated. This ensures that all angular features from both models are included in the analysis.
- Isopach contours or volume calculations are produced.

This method is less accurate than the full method because only the string points are compared with the triangulation of the other model, but it is less time-consuming than the full method.

#### Full and simple method comparison

Volumes calculated by major option PRISM when using both the simple and full isopachyte analysis methods yielded the following approximate errors in the simple isopachyte technique:

Cut            1.7%  
Fill            0.3%

This was based on the following test data:

	Full isopachyte (TRIANGLE 962)	Simple isopachyte (TRIANGLE 965)
<b>Calculated points</b>	<b>32317</b>	<b>7791</b>
<b>Calculated triangles</b>	<b>26300</b>	<b>13354</b>

<b>Modelfile records required</b>	<b>2630</b>	<b>1336</b>
<b>Approximate disk space required</b>	<b>5.3 Mbytes</b>	<b>2.7 Mbytes</b>

Triangulation model 1 contained 1949 points  
Triangulation model 2 contained 1556 points.

The results demonstrate that the simple isopachyte technique provides a solution within a reasonable band of error, with less demanding modelfile overheads.

### Modelfile storage

The storage and processing of a triangulation is carried out within the model file. It is advisable therefore to determine the model file requirements before generating the triangulation.

For triangulations, the number of triangles generated is approximately twice the number of string points in the model being triangulated (excluding points to be ignored or interpolated points). Ten triangles are stored in each model file record. Therefore to determine the number of model file records required,  $R_r$ :

$$R_r = \frac{2 * \text{no. of string points}}{10}$$

For example, a model containing 20,000 string points will require 4,000 free model file records.

For isopachyte triangulations, the model file record requirements are more complex, and it is not possible to estimate the size of the calculated triangulation.

- ◇ *If sufficient free records are not available within the modelfile, the triangulation will be terminated and the error message 'E060 INSUFFICIENT SPACE IN MODELFILE' will be displayed.*

## Major option TRIANGLE

Major option TRIANGLE is used to create a triangulated model for analysis or use by other major options such as -

- AREA
- DRAINAGE
- PRISM
- SECTION Minor options 177 and 178
- SURFACE
- VISUALISATION

A number of minor options may be used either singly or in combination to create the correct triangulation model. The options available are -

960	Triangulate a string model
961	Trim triangulation
962	Full ISOS from 2 models
963	Subdivide triangulation
964	ISOS from stored triangles
965	Simple ISOS from 2 models.
966	Grouping of triangles
967	Group triangles by criteria

## Access to major option TRIANGLE

IGENLT.DAT, GEN002, IGTRIAT.DAT, TRI001

Analysis options	TRIANGLE options
AREA	Triangulate a string model
TRIANGLE	Trim triangulation
SECTION	Subdivide triangulation
VOLUME	Full ISOS from 2 models
SURFACE	Simple ISOS from 2 models
PRISM	ISOS from stored triangles
	Grouping options
EDIT	Define system parameters
COPY	Define linear units
REPORT	End TRIANGLE

- ◇ *In graphics model names are defined after each minor option has been selected.*

## Global minor options

The global options 000, 017, 019, 900 and 999 may be used with TRIANGLE.

Option 019 has additional functionality specific to this major option.

## Minor option 017 Define system parameters

### Minor option 017

Field 1      ECHO - coordinates of points are printed out on triangulation.  
                 NOEC - cancels ECHO code.  
                 FLAT - allows flat triangles.  
                 NOFL - cancels flat code.

Minor option 019 Define selection mask

Minor option 019

- Field 1 Mask label relating to model 1.
- Field 4 +1.0 inclusive  
-1.0 exclusive  
+2.0 inclusive and treat as P strings  
+3.0 inclusive and treat as linked strings  
+5.0 inclusive sub reference mask  
-5.0 exclusive sub reference mask

◇ To select all strings, or to cancel the existing set of masks, or to reinitialise, leave all fields blank.

Minor option 960 Triangulate a string model

Minor option 960 produces a triangulation string held within the TRIA triangulation model (Model 3).

Input

Graphics

IGTRIAT.DAT, TRI001, TRI002, TRI008

TRIANGLE option:	Triangulation models	Triangulate a string model
Triangulate a string mode	String model name	New triangle label
Trim triangulator	Boundary model (optional)	Boundary label (optional)
Subdivide triangulation	Triangle storage model	Draw triangulation (T)
Full ISOS from 2 model:		Trim triangulation (T)
Simple ISOS from 2 model:		Define string masking
SOS from stored triangle:		
Grouping options:		
Define system parameter:		
Define linear unit:		
End TRIANGLE		

On Proceed from this menu, if 'Trim triangulation' is set to 'YES', the 'Trim triangulation' menu is displayed when the triangulation is complete, with details from this menu carried forward.

Linemode

Major option TRIANGLE



Model 1      Model to be triangulated Model to be triangulated.  
Model 2      Reference model model for boundary for boundary.  
 Model 3      Model used to store the triangulation Model used to store the triangulation.

◇ *Mode Models 1 & 2 is 1 & 2 must not be a TRIA triangulation models!*

Minor option 960

Field 1      String label used to define boundary for point selection.

\* Field 3      Label used to define name of triangulation.

◇ *The triangulation string will point to the initial triangle for this triangulation.*

◇ *The triangulation label will be as defined in field 3, and its subreference will be TRIN.*

◇ *The number of points indicator will record the number of triangles in the triangulation.*

◇ *Minimum and maximum indicators will store the extent of the triangulation.*

◇ *String dimension will be set to 09.*

◇ *Intersection points and label can be reported.*

◇ *When the entire triangulation is complete the system will advise with the message 'triangulation complete'.*

◇ *Where the triangulation exceeds 1000 points, the system will report progress at 20% intervals with the message eg 'triangulation 20% completed'.*

Example

```
MOSS
TRIANG,NORFDECK BDRY
TRIANG,NORFDECK
960,3=TRIA
999
```

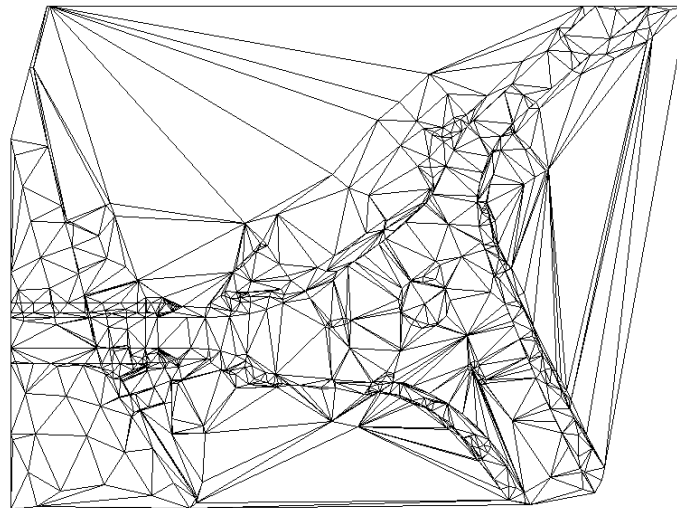


Figure 10 - 11 Example - Minor option 960

## Minor option 961 Trim triangulation

Produces a trimmed version of the triangulation.

### Input

### Graphics

IGTRIAT.DAT, TRI001, TRI003, TRI009

<b>TRIANGLE options</b>	<b>Trim triangulation models</b>	<b>Trim triangulation</b>
Triangulate a string model	Triangulation model	New triangle label
<b>Trim triangulation</b>	Boundary model (optional)	Triangle to be trimmed
Subdivide triangulation	Trimmed tria model name	Boundary label
Full ISOS from 2 models		Trimming method (T)
Simple ISOS from 2 models		Draw trimmed tria (T)
ISOS from stored triangles		Define string masking
<b>Grouping options</b>		
Define system parameters		
Define linear units		
End TRIANGLE		

### Linemode

```

Major option TRIANGLE
Model 1      Triangulation model

```

Model 2      Boundary model

Model 3      Model used to store the triangulation.

◇ *If 961 follows a 960, refer to 960 for model names.*

◇ *Model 2 must not be a TRIA triangulation model.*

**Minor option 961**

Field 1      String label used to define boundary for trimming.  
Leave blank to ignore boundary string.

\* Field 2      Existing triangulation label.

\* Field 3      Trimmed triangulation label.

Field 10     Code 1.0 if method A trimming (SHRINK) is required.  
Leave blank to invoke method B trimming (ALL).

Examples

```
MOSS  
TRIANG,NORFDECK BDRY  
TRIANG,NORFDECK  
961,,TRIA,TRMA,10=1.0  
999
```

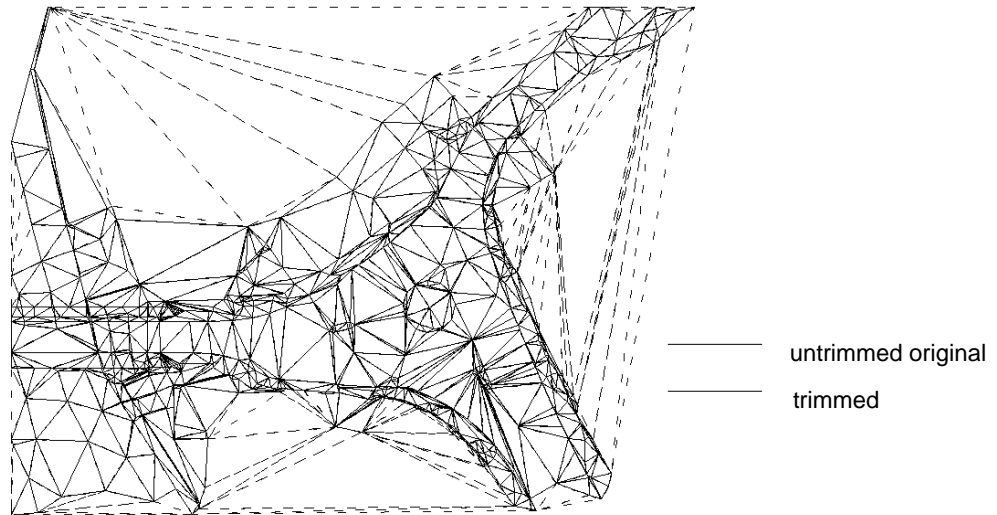


Figure 10 - 12 Example - Minor option 961 method A

```
MOSS  
TRIANG,NORFDECK BDRY  
TRIANG,NORFDECK  
961,,TRIA,TRMB  
999
```

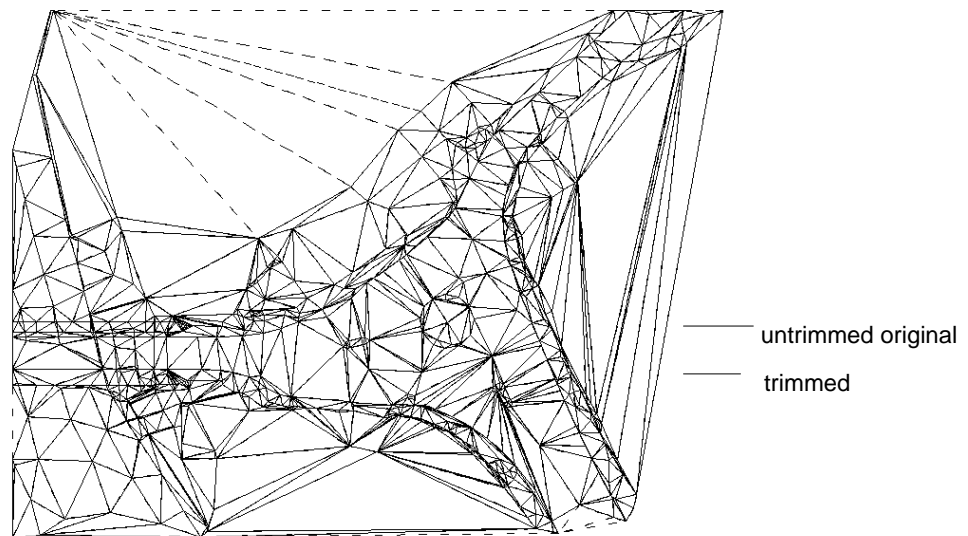


Figure 10 - 13 Example - Minor option 961 method B

## Minor option 962 Full ISOS from 2 models

Minor option 962 performs an isopachyte triangulation between existing and proposed surfaces. It produces a triangulation string held within the triangulation model defined as ISOS model name.

- ◇ *Minor option 965 performs a simpler but less accurate isopachyte triangulation. For a comparison between the two methods, refer to the theory section of this chapter.*
- ◇ *Minor option 964 provides similar facilities but uses stored triangulations. Option 962 calculates the triangulations during the calculation of the isopachyte triangulation.*

### Input

### Graphics

IGTRIAT.DAT, TRI001, TRI005, TRI011

TRIANGLE option:	Full ISOS from 2 models	Full ISOS from 2 models
Triangulate a string mode	String model 1	New ISOS label
Trim triangulation	String model 2	Boundary label 1 (opt)
Subdivide triangulation	Full ISOS model name	Boundary label 2 (opt)
Full ISOS from 2 model:		Draw triangulation (T)
Simple ISOS from 2 model:		Define string masking
SOS from stored triangle:		
Grouping options:		
Define system parameter:		
Define linear units:		
End TRIANGLE		

### Linemode

Major option TRIANGLE

Model 1 'Existing' string model to be used for Isopachyte triangulation.

Model 2 'Proposed' model to be used for Isopachyte triangulation.

\* Model 3 Model used to store ISOS triangulation.

◇ *Models 1 & 2 must not be a TRIA triangulation models.*

**Minor option 962**

Field 1       String label used to define boundary for point selection within model 1.

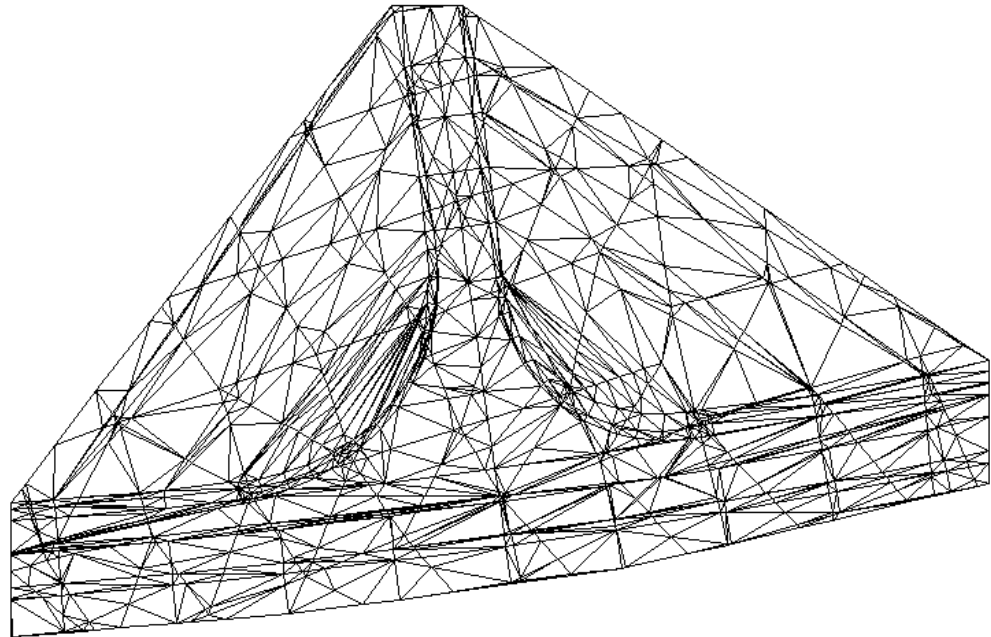
Field 2       String label used to define boundary for point selection within model 2.

Field 3       String label used to define name of isopachyte triangulation.

- ◇ *The triangulation string will point to the initial triangle for this triangulation.*
- ◇ *The triangulation label will be as defined in field 3, and its subreference will be ISOS.*
- ◇ *The number of points indicator will record the number of triangles in the triangulation.*
- ◇ *Where the triangulation exceeds 1000 points, the system will report progress at 20% intervals with the message eg 'triangulation 20% completed'.*

**Example**

```
MOSS
TRIANG, GROUND, JUNCTION
TRIANG, ISOS
962, 3=ISOS
999
```



**Figure 10 - 14 Example - Minor option 962**

**Minor option 963 Subdivide triangulation**

Minor option 963 produces a secondary triangulation string which represents a subdivision of the existing triangulation.

The accuracy of the basic triangulated surface depends on the original specification for model detail and the density of points. The resulting triangulation will faithfully reproduce the surface and features but may not be sufficiently detailed to produce smooth contours.

Various techniques may be used to curve fit the plan form of the contours produced from the primary triangulation but there is no guarantee that the result is an acceptable smooth surface and that the contours will not cross. Additionally this surface is not available for further analysis. The problem is resolved by introducing a refinement of the original triangulation to produce a more detailed and smoothed secondary triangular surface.

The technique adopted is to take each triangle within the primary triangulation and subdivide it into 4 smaller triangles by joining the mid

points of each side. The levels of the new vertices are derived, not by linear interpolation (which would make no difference), but by taking into account the slopes between adjacent triangles. Briefly the algorithm is as follows:-

- for each vertex of each triangle in model 1 calculate the surface normal, weighted by reference to neighbouring data.
- develop a refined triangular mesh, calculating the levels by reference to the levels and slopes of the existing triangulation.

In calculating the surface normals feature strings are given special consideration to ensure that whilst continuity is maintained, it nevertheless properly reflects the surface definition.

Input

Graphics

IGTRIAT.DAT, TRI001, TRI004, TRI010

TRIANGLE options	Subdivide Triangulation	Subdivide triangulation
Triangulate a string model	Triangulation model	New triangle label
Trim triangulation	Subdivided tria model name	Triangle to be sub-divided
Subdivide triangulation		Draw subdivided triang (T)
Full ISOS from 2 models		Define string masking
Simple ISOS from 2 models		
ISOS from stored triangles		
Grouping options		
Define system parameters		
Define linear units		
End TRIANGLE		

Linemode

Major option TRIANGLE

Model 1 Triangulation model.

Model 2 Blank.

Model 3 Model used to store subdivided triangulation.

Minor option 963

- \* Field 2 Primary (existing) triangulation label.
- \* Field 3 Secondary triangulation label.

◇ *Minor option 963 may be repeated several times to obtain an improved triangulation for producing smoothed contours.*



Example

```

TRIANG, BASE MODEL
TRIANG, TRIANGLE MODEL
    Produce primary triangulation
960,3=TRIX
    Produce secondary triangulation
963,2=TRIX,3=STRI
    Subdivide again for improved smoothing.
963,2=STRI,3=SSTR
    
```

Minor option 964 ISOS from stored triangles

Generates an isopachyte triangulation from two simple triangulations.

Input

Graphics

IGTRIAT.DAT, TRI001, TRI006, TRI012

TRIANGLE option:	ISOS from stored triangles	ISOS from stored triangles
Triangulate a string mode	Triangulation model 1	New ISOS label
Trim triangulator	Triangulation model 2	First triangulation label
Subdivide triangulation	ISOS model name	Second triangulation label
Full ISOS from 2 model:		Draw triangulation (T)
Simple ISOS from 2 model:		Define string masking
SOS from stored triangle:		
Grouping options:		
Define system parameter:		
Define linear units:		
End TRIANGLE		

Linemode

Major option TRIANGLE

Model 1 'Existing' triangulation model.

Model 2 'Proposed' triangulation model.

Model 3 Model used to store ISOS triangulation.

Minor option 964

- \* Field 1 'Existing' triangulation label.
- \* Field 2 'Proposed' triangulation label.

- \* Field 3 Isopachyte triangulation label.
  - ◇ *If two triangulation models are coded on the first major option record then the 'Existing' triangulation must be in model 1 and the 'Proposed' triangulation must be in model 2.*
  - ◇ *Where the triangulation exceeds 1000 points, the system will report progress at 20% intervals with the message eg 'triangulation 20% completed'.*

Example

```
MOSS
TRIANG, GROUND TRIANG, JUNCTION TRIANG
TRIANG, ISOS
964, TRIG, TRIJ, TISO
999
```

Minor option 965 Simple ISOS from 2 models

Minor option 965 performs a simple isopachyte triangulation between existing and proposed surfaces and produces a triangulation string.

- ◇ *Minor options 962 and 964 perform a more complex and more accurate isopachyte triangulation. For a comparison between the two methods, refer to the theory section of this chapter.*
- ◇ *Triangulations for both models are calculated during the production of the isopachyte triangulation.*

Input

Graphics

IGTRIAT.DAT, TRI001, TRI022, TRI023

TRIANGLE option:	Simple ISOS from 2 models	Simple ISOS from 2 models
Triangulate a string mode	String model 1	New ISOS label
Trim triangulation	String model 2	Boundary label 1 (opt)
Subdivide triangulation	Simple ISOS model name	Boundary label 2 (opt)
Full ISOS from 2 model:		Draw triangulation (T)
Simple ISOS from 2 model:		Define string masking
SOS from stored triangle:		
Grouping options:		
Define system parameter:		
Define linear units:		
End TRIANGLE		

Linemode

Major option TRIANGLE

Model 1 'Existing' string model to be used for isopachyte triangulation.

Model 2 'Proposed' model to be used for isopachyte triangulation.

Model 3 Model used to store ISOS triangulation.

◇ *Models 1 & 2 must not be a TRIA triangulation models.*

Minor option 965

Field 1 String label used to define boundary for point selection within model 1.

Field 2 String label used to define boundary for point selection within model 2.

Field 3 String label used to define name of isopachyte triangulation.

◇ *The triangulation label will be as defined in field 3, and its subreference will be QISO.*

◇ *The number of points indicator will record the number of triangles in the triangulation.*

◇ *Where the triangulation exceeds 1000 points, the system will report progress at 20% intervals with the message eg 'triangulation 20% completed'.*

## Minor option 966 Grouping of triangles

Triangles may need to be grouped together for various reasons. For example, they may be grouped to represent a single catchment area for drainage analysis, or for efficient assignment of colour and material type for use within major option VISUALISE.

Triangles may be grouped interactively or in linemode. (using a seed string only).

**IGIADST.DAT, TRI001, TRI007, TRI013**

<b>TRIANGLE options</b>	<b>Triangle grouping models</b>	<b>Grouping options</b>
Triangulate a string model	Boundary model	Group triangles by seeding
Trim triangulation	Triangulation model	Group individual triangles
Subdivide triangulation		Group triangles by criteria
Full ISOS from 2 models		Reset group codes
Simple ISOS from 2 models		
ISOS from stored triangles		
Grouping options		
Define system parameters		
Define linear units		
End TRIANGLE		

## Group triangles by seeding

IGIADST.DAT, TRI013, TRI014

Grouping options	Group triangles by seeding
Group triangles by seeding	Triangulation string label
Group individual triangles	Group code
Group triangles by criteria	Dummy link creation No
Reset group codes	Define string masking No
	Link tolerance 0.01
	First triangle
	Boundary string label
	Seed string label
	Hatching switch (T)
	Show ungrouped triangles

**Triangulation string label** is the name of the triangle string to be used for grouping, and may be picked from the screen or entered via the keyboard.

**Group code** is the name of the triangle group being formed, and is entered via the keyboard. The group code will be assigned to all the selected triangles when the grouping is accepted.

**Dummy link creation** enables you to prevent seeding spilling out of a desired area.

**String masking** can be used so that selected strings are ignored by the seeding process.

The **link tolerance** is the minimum length a triangle side can be without being a dummy link; in other words, triangle sides shorter than the link tolerance are not considered for further seeding. See 'Dummy links' for further details.

Triangles for grouping may be defined by a boundary string or by seeding using a first triangle or a seed string.

Selecting **first triangle** will group all the triangles subject to the following conditions:

- One or more of a triangle's sides is coincident with those of the first triangle or a triangle already seeded in the group.
- If a side of a triangle includes any string link used to create the triangulation, the side may not be considered for further seeding.
- Null triangles (ie, those with a level of -999 on any vertex) may not be seeded.

Selecting **boundary string** will group all triangles contained within the boundary string.

Selecting **seed string label** allows you to group triangles using a seed string. See 'Group triangles using seed string' for further information.

The **hatching switch** may be toggled between 'stored', 'temp' and 'retain'. Stored hatching will be stored on the .DPF when the grouping is accepted. Temporary hatching will be deleted when the grouping is accepted or rejected. Retain hatching will be kept on screen until you exit the major option.

Selecting **show ungrouped triangles** will highlight all the triangles which do not currently belong to any group.

When proceed is selected for the first time the triangles will be seeded and hatched. A menu will then be displayed which prompts you to accept or reject the seeding.

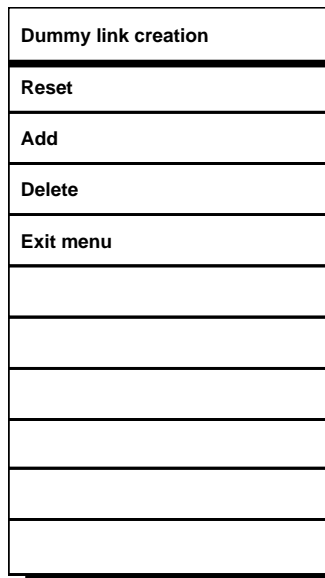
### Dummy links

When triangles are grouped the procedure is to select an initial triangle in the group and assign a group code, all adjacent triangles will then be given that group code unless a triangle side is formed from a string link or a null triangle is encountered. In these cases the next adjacent triangle is not considered. This process is called seeding. A triangle group can be added to by subsequent seeding operations. Also, a single group of triangles need not be contiguous.

In some situations the user may wish to restrict the seeding by introducing a dummy link. This changes the property of a triangle side that would not normally terminate seeding to be a string link which will restrict seeding.

If you select **Dummy link creation** you will be presented with this menu:

IGIADST.DAT, TRI018



Dummy link creation offers you the following options -

**Reset** - deletes all dummy links created.

**Add** - creates dummy links. You must pick the side of a triangle where you require a dummy link. The link will be highlit, proceed to accept the link, quit to reject the link or use Link amend.

**Link amend** - when you select this box you may toggle between the sides of the triangle highlighting each side in turn. Proceed allows you to select another dummy link. A second proceed terminates the dummy link creations.

**Delete** - deletes a dummy link. You are requested to pick the link to be deleted, once picked the link will no longer be highlit. Proceed will terminate Delete.

◇ *When you return to the Grouping of triangles menu, you will need to reselect the 'first triangle' to re-establish its hatching.*

- ◇ *When you return to the Grouping of triangles menu, the Dummy link creation field will state 'yes' if you have created any links.*
- ◇ *When you exit from grouping options all dummy links will be deleted if you have created any stored hatching.*

### String masking

If you select **string masking** you will be presented with this menu -  
You can select strings to be masked or unmasked from the seeding operation.

IGIADST.DAT, TRI015

Define string masking
Exclude strings
Exclude all strings
Include strings
Cancel masks
Report masks
Exit menu

**Exclude strings** - you must select a string to be masked.

**Exclude all strings** - you will exclude all strings.

**Include strings** - you must select a string to be unmasked.

**Cancel masks** - deletes all masks.

**Report masks** - displays a list of currently defined masks.

- ◇ *Exit from the grouping options cancels all mask selections.*



## Group triangles using seed string

Selects points on a string as seed points for grouping triangles. In this way, seed points may be pre-defined in the model data.

### Input

#### Graphics

IGIADST.DAT, TRI014, TRI025

Group triangles by seeding	Group by seed string
Triangulation string label	Seed string label
Group code	Start chainage/ X coord
Dummy link creation No	Start point no./ X coord
Define string masking No	End chainage/ Y coord
Link tolerance 0.01	End point no./ Y coord
First triangle	
Boundary string label	
Seed string label	
Hatching switch (T)	
Show ungrouped triangles	

### Linemode

Major option TRIANGLE

Model 1 String model

Model 2 Reference model

Model 3 Model used to store the triangulation group.

◇ *Models 1 & 2 must not be a TRIA triangulation models.*

Minor option 966

Field 1 Seed string label

A partial label may be used. If a partial label is specified, the seed strings must be contained in the reference model. If a full label is specified, the seed string may be contained in either the string or the reference model.

Field 2 Group code

4 alphanumeric characters

Field 3 Triangulation string label

Field 4 Single seed point indicator

0 Multiple seed points

1 Single seed point

Fields 5 & 6 SPRD of start point on seed string

Field 7 Link tolerance (default 0.010)

Fields 8 & 9 SPRD of end point on seed string

◇ *String masking can only be used to define which strings are to form the grouping barrier. It cannot be used to define seed string selection.*

### Examples

To group triangles representing houses into one group for drawing purposes, using one point strings beginning with the letter C and a link tolerance of 0.05:

```
966 , C , HOUS , TRIA , 7=0 . 05
```

To group triangles using points 3, 4 and 5 on the reference string P001:

```
966 , P001 , GRP1 , TRIA , 6=3 , 9=5
```

To group triangles using the seed point at coordinates ( 1000, 1000 ):

```
966 , , GRP2 , TRIA , 1 , 1000 , 1000
```

## Group individual triangles

IGIADST.DAT, TRI013, TRI024

Grouping options	Group individual triangles
Group triangles by seeding	Triangulation string label
Group individual triangles	Group code
Group triangles by criteria	Hatching switch (T)
Reset group codes	Include triangle
	Exclude triangle

**Triangulation string label** is the label of the triangulation containing the triangles you wish to group.

**Group code** determines the group to which you wish to add triangles. If the group already exists, select a triangle which belongs to the group and the group code will be displayed in the scrolling menu. If the group is a new group, type the group code from the keyboard.

The **hatching switch** may be toggled between 'stored', 'temp' and 'retain'. Stored hatching will be stored on the .DPF when the grouping is accepted. Temporary hatching will be deleted when the grouping is accepted or rejected. Retain hatching will be kept on screen until you exit the major option.

**Include triangle** allows you to add a triangle to the selected group. When you select a triangle, the triangle is hatched and the triangle's number is displayed in the scrolling menu area. The hatched triangle is added to the group when you finish selecting triangles and select Proceed.

◇ *Triangles may be selected in succession without returning to the scrolling menu area. Select Quit when you wish to return to the menu area.*

**Exclude triangle** cancels the addition of a selected triangle so that it will not be added to the group when Proceed is selected.

When you have finished selecting triangles, select Proceed to add the triangles to the specified group. Select Quit to cancel the selected triangles so that they are not added to the group.

## Reset group codes

IGIADST.DAT, TRI013, TRI017

Grouping options	Reset group codes
Group triangles by seeding	Triangulation string label
Group individual triangles	Group code
Group triangles by criteria	
Reset group codes	

**Triangulation string label** is the label of the triangulation containing the triangle group to be selected.

**Group code** determines the triangle group whose group codes are to be cancelled. Select any triangle in the group or type the group code to cancel the group codes of all the triangles in the group.

### Minor option 967 Group triangles by criteria

Defines criteria for grouping triangles.

Input

Graphics

IGIADST. DAT, TRIO13, TRIO26

Grouping options	Group by criteria
Group triangles by seeding	Triangulation label
Group individual triangles	Group name of triangles
Group triangles by criteria	Hatching switch (T)
Reset group codes	Lower level
	Upper level
	Start slope
	End slope
	Start bearing
	End bearing

Linemode

Major option TRIANGLE

Model 1 String model

Model 2 Reference model

Model 3 Model used to store the triangulation group.

◇ *Models 1 & 2 must not be TRIA triangulation models.*

Minor option 967

Field 2 Group name of triangles, which must be four characters.

Field 3 Triangulation label, which must be four characters.

Field 5 Lower level, above which all triangles are grouped

Field 6 Upper level, below which all triangles are grouped

Field 7 Start slope ( decimal fraction ), above which triangles are grouped

Field 8 End slope (decimal fraction ), below which all triangles are grouped

Field 9 Start whole circle bearing for aspect

Field 10 End whole circle bearing for aspect

◇ *Fields 7 and 8 must be zero or positive.*

◇ *Flat triangles are included in the colour fill when whole circle bearings are specified.*

Example

Add group codes to triangles between levels of 27 and 35m whose angle of slope is between 0.025 (1 in 40) and 0.05 (1 in 20) and only those with aspect between the bearings of 45 and 90 degrees.

```
967, , ABCD, TRIX, , 27.0, 35.0, 0.025, 0.05, 45.0, 90.0
```

## Reset group codes

IGIADST.DAT, TRI013, TRI017

Grouping options	Reset group codes
Group triangles by seeding	Triangulation string label
Group individual triangles	Group code
Group triangles by criteria	
Reset group codes	

**Triangulation string label** is the label of the triangulation containing the triangle group to be selected.

**Group code** determines the triangle group whose group codes are to be cancelled. Select any triangle in the group or type the group code to cancel the group codes of all the triangles in the group.

## Section 177/178

This information is a copy of that found in Chapter 9. It is placed here because of the association of these two minor options with triangulated models. For full details on access to and model selection for these options refer to Chapter 9.

### Minor option 177 Long - through triangulation

Determination of a long section along a previously created string by threading through a triangulation.

#### Input

#### Graphics

IGSECTT.DAT, SEC002, SEC011

SECTION option detail:	Long - thru triangulation
Define section param:	Reference string
Define linear units:	Triangulation label
Define string masking:	Section label
Long - between 2 point:	Start chainage / X coord
Long - along a string:	Start point no / Y coord
Cross - relative to string:	End chainage / X coord
Cross - relative to master:	End point no. / Y coord
Visibility along section:	
Visibility against section:	
Long - thru triangulation:	

#### Linemode

##### Minor option 177

- \* Field 1 Reference string
- \* Field 2 Triangulation label
- \* Field 3 Section label

If the label in field 3 is the same as the label in field 1, only levels on the reference string are amended.

Field 5 & 6 SPRD of start

Field 8 & 9 SPRD of end

◇ *A drainage string may be used as the reference string.*

**Derive the level at a point****Minor option 177**

- \* Field 2      Triangulation label
- Field 5 & 6   Code the easting and northing of the point.

**Derive the level of a point on a string****Minor option 177**

- \* Field 1      Reference string
  - \* Field 2      Triangulation label
  - Field 4      Code 1.0 to indicate single point identifier
  - Field 5 & 6   SPRD of point
- ◇ *This use of the option does not amend levels on the reference string.*

**Derive the levels at a series of points along a string****Minor option 177**

- \* Field 1      Reference string
  - \* Field 2      Triangulation label
  - Field 5 & 6   SPRD start
  - Field 8 & 9   SPRD end
- ◇ *This use of the option does not amend levels on the reference string.*

## **Minor option 178    Cross - through triangulation**

Extraction of a series of cross section perpendicular to a previously created string at a regular interval by threading through a triangulation.



Input

Graphics

IGSECTT.DAT, SEC002, SEC012

SECTION minor options	Cross -thru triangulation
Long - thru triangulation	Reference string
Cross - thru triangulation	Triangulation label
End SECTION	Section set initial char.
	Chainage interval
	Start chainage / X coord
	Start point no / Y coord
	Leftmost offset
	End chainage / X coord
	End point no. / Y coord
	Rightmost offset

Linemode

Minor option 178

- \* Field 1      Reference string
- \* Field 2      Triangulation label
- \* Field 3      Section set initial character
- Field 4      Chainage interval, if blank use all points on the reference string
- Field 5 & 6    SPRD of start
- Field 7      Leftmost offset
- Field 8 & 9    SPRD of end
- Field 10     Rightmost offset.

IGSECTT.DAT, SEC002      SEC011

IGSECTT.DAT, SEC002, SEC012

# Major option SURFACE

Major option SURFACE is used to generate contours and isopachytes (ISOS) from a triangulated model produced by major option TRIANGLE. It will also analyse the surface to create ridge and valley strings from which surface flow data may be generated.

The minor options available are -

- 970           Generate contours  
              Create contours from a triangulation created by major option TRIANGLE.
- 971           Generate ISOS (Isopachytes)
- 972           Generate ridges/valleys/flow lines  
              Create a single ridge and/or valley string from a triangulation created by major option TRIANGLE.
- 973           Generate flow lines  
              Line colour selection.

◇ *Line colour selection is only available in graphics.*

## Access to major option SURFACE

IGENLT.DAT, GEN002

Analysis options
AREA
TRIANGLE
SECTION
VOLUME
<b>SURFACE</b>
PRISM
EDIT
COPY
REPORT

Selecting SURFACE will cause display of the 'Model for SURFACE' menu.

## Model for SURFACE

### Input

#### Graphics

IGSURFT.DAT, SUR001, SUR002

Models for SURFACE	SURFACE option details
Triangulation model	Define system parameters
Surface model	Define linear units
	Define string masking
	Generate contours
	Generate isopachytes
	Generate ridges/vall/flow
	Line colour selection
	End SURFACE

### Linemode

Major option SURFACE

Model 1 The triangulation model.

Model 2 Boundary model

Major option SURFACE

Model 3 Model used to store contours, ridge and valley strings, or flow line data.

## Global minor options

The global minor options 000, 017, 019, 900 and 999 may be used with minor options 970, 971, 972 and 973 in SURFACE.

## Minor option 019 Define selection mask

### Minor option 019

Field 1 Mask label

Field 4 +4.0 mask of strings which are to cause bearing discontinuities  
-4.0 mask of strings which are not to cause bearing discontinuities

◇ *To select all strings, or to cancel the existing set of masks, or to reinitialise, leave all fields blank.*

### Bearing discontinuities in contour strings

A bearing discontinuity is sometimes required in contour strings which intersect feature strings. This gives a break in curve fitting when drawing the contours with detail interpretation.

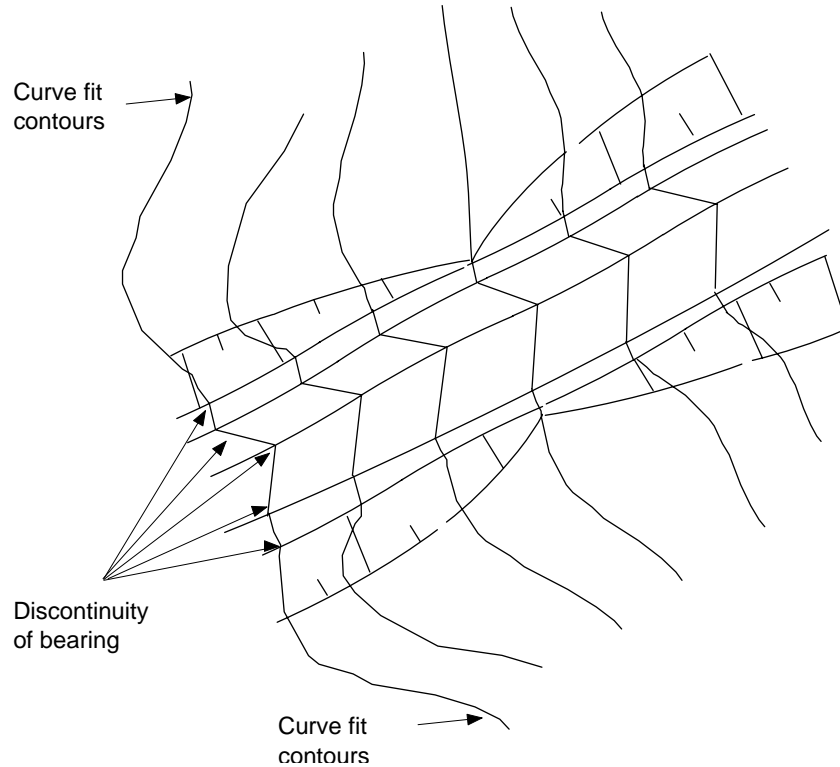
### Example

When drawing contours of a merged road model, you may wish to curve fit the contours over the open field area but not over the design area (eg, verges, channels etc).

To achieve this:

- Triangulate the merged model using major option TRIANGLE.
- Create contours from the triangulation, masking out any strings which do not require a bearing discontinuity.

By default, a bearing discontinuity is added to a contour string when it crosses a triangle side formed from a string link.



**Figure 10 - 15 Bearing discontinuities and curve fitting**

Insert bearing discontinuities in contours which cross all strings except 'L' strings:

```

TRIANG, MERGED MODEL
TRIANG, MERGED TRIGS
960, 3=TRIG
999
SURFACE, MERGED TRIGS
SURFACE, MERGED CONTS
019, L, 4=-4
970, 4=5, 7=10
DRAW, MERGED CONTS
803, 7=500
812, SPL1, 4=0.01
825
999
    
```

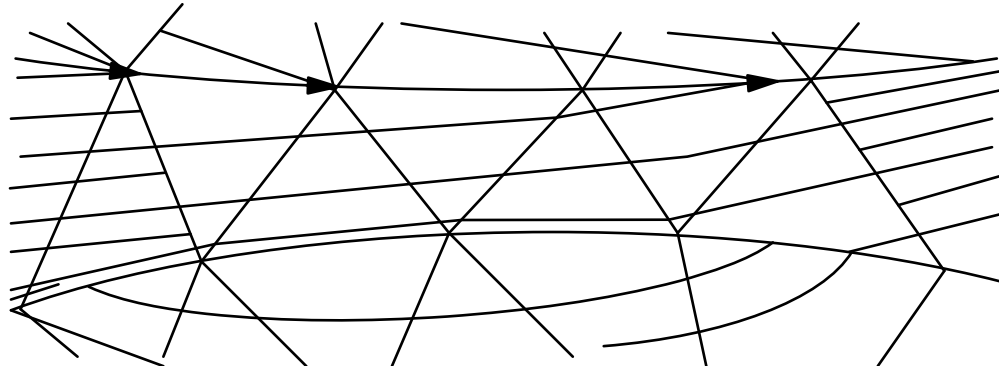
## Minor option 970 Generate contours

Minor option 970 will create contours from a triangulation created by major option TRIANGLE.

Use a boundary whenever possible to avoid extended calculation. It is recommended that the triangulation used is generated by minor option 961.

This will minimise the calculation time as the area of search is limited by the trimming of the triangulation to a boundary.

The specified normal contour interval can be overruled if the slope of a triangle exceeds a defined critical value. In this case the contour interval is amended to the new value. This feature overcomes the problem of congested contours on steep slopes.



**Figure 10 - 16 Example - change of contour interval on steep slope**

Contours can be omitted in areas where the slope of the triangles exceeds a specified slope. This is to allow the removal of areas of congested contours.

A prominent contour interval may be specified with an associated initial character for the string label. This permits these strings to have labels which are different from the other contours and allows them to be drawn as different string types by the plotting options.

In addition to the above general features you may request a single contour at a particular level of interest. They may also define a band width within which contours are generated. This enables the plotting of contours between two extremes in a defined colour.

Input

Graphics

IGSURFT.DAT, SUR002, SUR003

SURFACE option details	Generate contours
Define system parameters	Triangulation label
Define linear units	Char for norm interval
Define string masking	Char for prom. interval
Generate contours	Normal interval
Generate isopachytes	Special interval
Generate ridges/vall/flow	Slope for interval change
Line colour selection	Prominent interval
End SURFACE	Slope above which omitted
	Level above which req.
	Level below which req.

Linemode

Minor option 970

- \* Field 1 Required triangulation label.
- Field 2 String label initial character for normal contour interval. Default = D.
- Field 3 String label initial character for prominent contour interval. Default = 0 (zero).
- Field 4 Normal contour interval. (Default = 1.0. unless field 9 or 10 is coded).
- Field 5 Special contour interval to be applied when slope exceeds value in field 6; if omitted the normal contour interval is assumed.
- Field 6 Slope for interval changes from value in field 4 to that specified in field 5. Expressed as a decimal fraction (1 in 20 = 0.05); default = 1.0.
- Field 7 Prominent contour interval. Default 5 : 1 normal contour interval.
- Field 8 Slope above which omitted. Expressed as a decimal fraction; default = 200.
- Field 9 Level above which contours are required. The lowest contour is generated at the nearest multiple of the contour interval below this value.
- Field 10 Level below which contours are required. The highest contour is generated at the nearest multiple of the contour interval above this value.

- ◇ *If an identical initial character is coded into both fields 2 and 3 an error message is issued and the process will not proceed until the situation is corrected.*
- ◇ *To obtain all contours above a level code field 9.*
- ◇ *To obtain all contours below a level code field 10.*
- ◇ *To obtain all contours between two levels code fields 9 and 10.*
- ◇ *To obtain a single contour code field 9, do not code field 4.*
- ◇ *The prominent contour interval must be a multiple of the normal contour interval.*

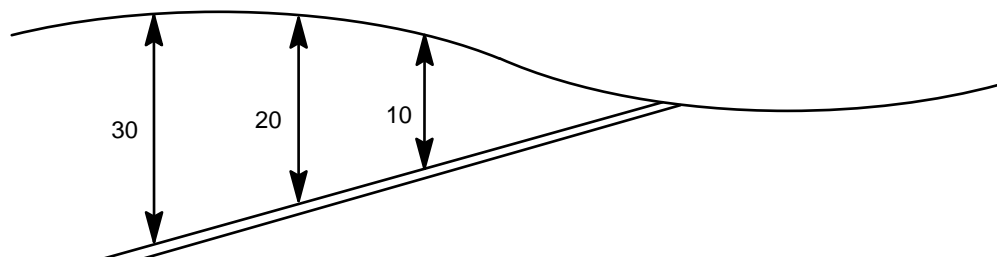
**Example**

```
MOSS
SURFACE, SIMPLE DESIGN TRIANG
SURFACE, SIMPLE DESIGN CONTOURS
970, TRIM, C, A
999
```

```
MOSS
SURFACE SIMPLE DESIGN TRIANG
SURFACE SIMPLE DESIGN CONTOURS
970TRIMC A
PLAN AREA = 37987.772
SLOPE AREA = 38639.897
MIN LEVEL = 40.620
MAX LEVEL = 72.820
999
```

**Minor option 971 Generate isopachytes**

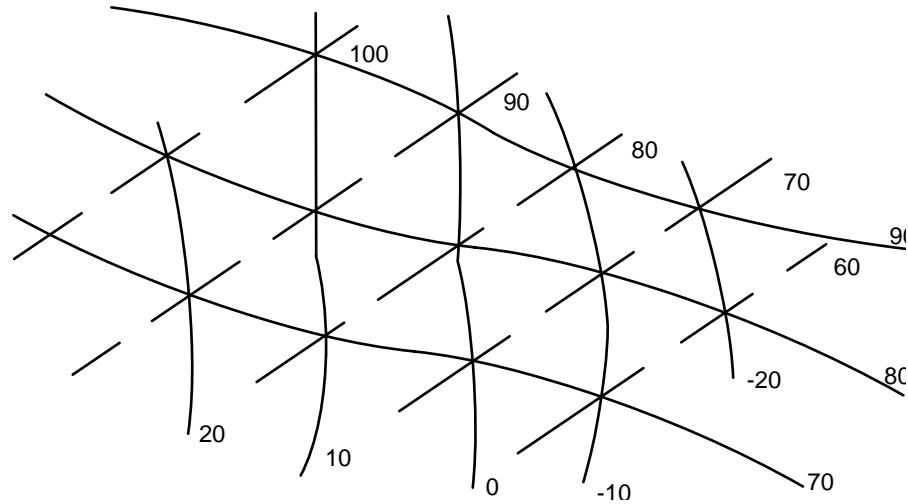
Isopachytes, or simply isopachs, are essentially contours but rather than being contours describing a surface they are contours of the differences between two surfaces. Their origin is in mining for determining relative contours between two strata and in fact they simplify a complex three dimensional relationship between two strata to a simple topological model based on a zero datum. The isopachyte analysis may be used to produce relative contours and volumes between the respective strata or layers.



**Figure 10 - 17 Isopachytes - contour of level difference**



Isopachs may be produced manually by comparing the contours defining two overlapping surfaces and drawing respective isopachs through the intersections of the sets of contours.



**Figure 10 - 18 Isopachyte contours**

Isopachs have wide spread engineering applications and may be used as a design technique, for analysis and for graphic presentation :-

- Overlay surface design in highway and airport resurfacing projects.
- Production of drawings for resurfacing contracts.
- Landscape analysis for the determination of the relation of two complex surfaces to detect the intersection plane (zero isopach) and maximum cut and fill depths.
- Surface comparison for determining differences to indicate:-

Land erosion  
Under water material movement  
Settlement  
Earthwork movement eg dams

- Mining and quarrying applications:-

Strata and seam thickness contours  
Over burden thickness  
Surface cover  
Subsidence

The method used to automatically produce isopachs relies on the triangulation of each surface to ensure all the surface features are considered. It is a three stage process and the first stage triangulates the first surface and compares the strings of the second surface with it producing equivalent strings containing the level differences.

The second stage, similarly, compares the strings of the first surface with the triangulation of the second surface, and also produces equivalent

strings containing the level differences. The third stage triangulates all the level difference strings and this ensures that all the angular features in both surfaces are included in the analysis.

**Input**

Graphics

IGSURFT.DAT, SUR002, SUR004

<b>SURFACE option details</b>	<b>Generate isopachytes</b>
Define system parameters	ISOS triangulation label
Define linear units	Char for normal interval
Define string masking	Char for prom interval
Generate contours	Normal interval
<b>Generate isopachytes</b>	Special interval
Generate ridges/vall/flow	Slope for interval change
Line colour selection	Prominent interval
End SURFACE	Slope above which omitted
	Level diff above which req
	Level diff below which req

Linemode

Minor option 971

- \* Field 1 Required triangulation label.
- Field 2 String label initial character for normal isopachyte interval. Default = D.
- Field 3 String label initial character for prominent isopachyte interval. Default = 0 (zero).
- Field 4 Normal isopachyte interval. (Default = 1.0 unless field 9 or 10 is coded).
- Field 5 Special isopachyte interval to be applied when slope exceeds value in field 6; if omitted the normal isopachyte interval is assumed.
- Field 6 Slope for interval changes from value in field 4 to that specified in field 5. Expressed as a decimal fraction (1 in 20 = 0.05); default = 1.0.
- Field 7 Prominent isopachyte interval. Default 5 : 1 normal isopachyte interval.

- Field 8 Slope above which omitted. Expressed as a decimal fraction; default = 200.0.
- Field 9 Level difference above which isopachytes are required. The lowest isopachyte is generated at the nearest multiple of the isopachyte interval below this value.
- Field 10 Level difference below which isopachyte are required. The highest isopachyte is generated at the nearest multiple of the isopachyte interval above this value.
- ◇ *To obtain all isopachytes above a level code field 9.*
  - ◇ *To obtain all isopachytes below a level code field 10.*
  - ◇ *To obtain all isopachytes between two levels code fields 9 and 10.*
  - ◇ *To obtain a single isopachyte code field 9, do not code field 4.*
  - ◇ *The prominent isopachyte interval must be a multiple of the normal isopachyte interval.*

### Example

```

MOSS
SURFACE, ROAD ISOPACHS TRIANG
SURFACE, ROAD ISOPACHS
971, TRIS, C, A, 0.05
999

MOSS
SURFACE ROAD ISOPACHS TRIANG

SURFACE ROAD ISOPACHS
971TRISC A 0.05

PLAN AREA = 623.152
SLOPE AREA = 623.370
MIN LEVEL = -0.960
MAX LEVEL = 0.065
999

```

## Minor option 972 Generate ridges/valleys/flow lines

Minor option 972 will generate from a triangulation a single ridge string, a single valley string and flow lines. The ridge and valley strings will contain discontinuities.

The purpose of these ridge and valley strings is to provide data for minor option 973 from which flow lines may be generated.

The algorithm used to generate these strings will -

- generate a ridge string along the common side of two triangles where the gradient of the triangles is zero or less than zero.
- generate a valley string along the common side of two triangles where the gradient of the triangles is zero or greater than zero.

Input

Graphics

IGSURFT.DAT, SUR002, SUR005

<b>SURFACE option details</b>	<b>Generate ridges/vall/flow</b>
Define system parameters	Triangulation label
Define linear units	Ridge string label
Define string masking	Valley string label
Generate contours	Generate flow lines (T)
Generate isopachytes	
Generate ridges/vall/flow	
Line colour selection	
End SURFACE	

- ◇ *Generate flow lines set to yes: proceed will automatically create ridge and valley strings and display the 'Generate flow lines menu'.*
- ◇ *Generate flow lines set to no: proceed will automatically create ridge and valley strings and return to SURFACE options menu.*

Linemode

Minor option 972

- \* Field 1 Required triangulation label.
- \* Field 2 String label for ridge string.
- \* Field 3 String label for valley string.
- Field 4 Code 1 if an option 973 is to follow to generate flow lines.

Example

```

MOSS
DELETE, SIMPLE ROAD RIDVAL
CREATE, SIMPLE ROAD RIDVAL
SURFACE, SIMPLE DESIGN TRIANG
SURFACE, SIMPLE ROAD RIDVAL
972, TRME, RIGE, VALL
999
999
    
```

## Minor option 973    Generate flow lines

Minor option 973 will generate flow lines through the triangulation at the same time as ridge strings. The flow lines are used in major option DRAINAGE to assist in placing drainage gullies.

Minor option 973 must be preceded by a minor option 972.

### Input

### Graphics

IGSURFT.DAT, SUR006

Generate flow lines
Char for flow lines
Tolerance for interval

◇ *The Generate flow lines menu is only displayed if the Generate flow lines toggle (see minor option 972) is set to yes.*

### Linemode

#### Minor option 973

- \* Field 2      Initial character for storing flow lines.
- Field 4      Plan tolerance for interval of flow lines (default 5m).  
The tolerance is a value which determines the frequency at which flow lines are generated. The number of flow lines produced from each side of the triangulation is equal to the length of the side divided by the tolerance, with the result being rounded down. If the tolerance is greater than the side length, one flow line will be generated from the mid point of the side. If the side length is less than 2mm no flow line will be generated.

◇ *Minor option 973 must be preceded by minor option 972.*

### Example

MOSS  
 DELETE, SIMPLE ROAD FLOW  
 CREATE, SIMPLE ROAD FLOW  
 SURFACE, SIMPLE DESIGN TRIANG  
 SURFACE, SIMPLE ROAD FLOW  
 972, TRME, RIGE, VALL, 1.0  
 973, , F, , 5  
 999

## Line colour selection

### Input

### Graphics

IGSURFT.DAT, SUR002, SUR007

SURFACE option details	Line colour selection
Define system parameters	Norm int (T)
Define linear units	Prom int (T)
Define string masking	Ridges (T)
Generate contours	Valleys (T)
Generate isopachytes	Flowlines (T)
Generate ridges/vall/flow	
Line colour selection	
End SURFACE	

- ◇ *For each line type the colour may be selected by toggle from the available colours selection.*
- ◇ *The default colours use five of the available colours selection.*

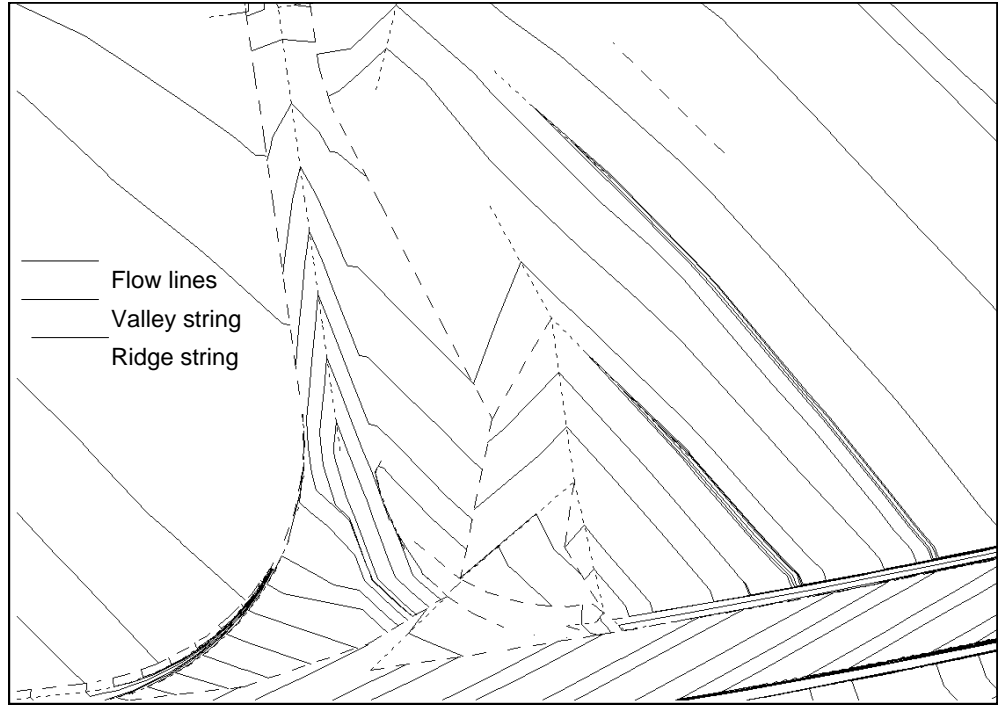


Figure 10 - 19 Example - showing use of 972, 973 and Line style

## Major option PRISM

Major option PRISM allows calculation of volume information from a triangulated model created by major option TRIANGLE. Major option VOLUME provides similar facilities for a non-triangulated model.

The minor options provided are -

- 910            Volume from triangulation
- 911            Volume from isopachyte
- 912            Mean thickness of ISOS.

### Access to major option PRISM

IGENLT.DAT, GEN002

Analysis options
AREA
TRIANGLE
SECTION
VOLUME
SURFACE
<b>PRISM</b>
EDIT
COPY
REPORT



## Models for PRISM

### Input

### Graphics

IGPRIST.DAT, PRI001, PRI002

Models for PRISM	PRISM option details
Triangulation model	Define system parameters
Boundary/Reference model	Define linear units
	Define string masking
	Volume from triangulation
	Volume from isopachyte
	Mean thickness of ISOS
	End PRISM

### Linemode

Major option PRISM

Model 1 Required triangulation model.

Model 2 Model used for reference (boundary) string.

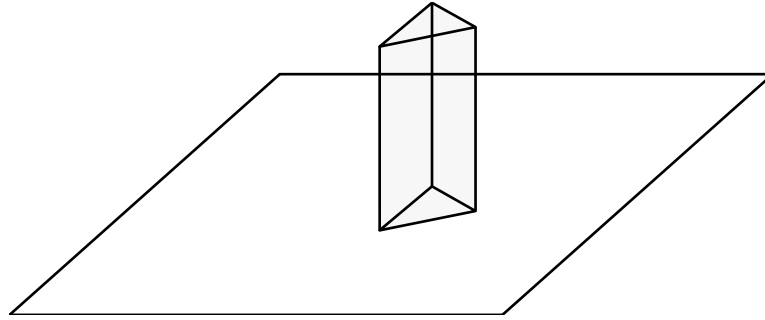
## Global minor options

The global minor options 000, 017, 019, 900 and 999 may be used with minor options 910, 911, and 912 in PRISM.

## Minor option 910 Volume from triangulation

The basic unit of a triangle is an accurate means for deriving volumes and cut/fill balances. If a surface has been well represented by strings and then triangulated, the resulting mosaic of triangles faithfully reflects the true surface.

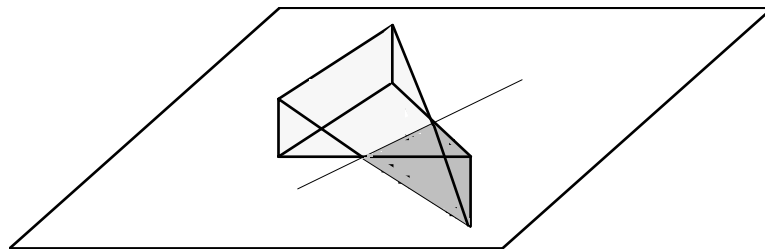
The simplest volume to calculate is that formed by the projection of a triangle onto a flat plane.



**Figure 10 - 20** Projection of a triangle onto a flat plane

The total volume calculation for a simple triangulation is the straightforward summation of all the relevant triangles either within a boundary or restricted by one of the trimming methods (Major option TRIANGLE - option 961).

If the flat plane actually intersects a triangle then there is an element of cut and fill associated, since some of the triangle lies above and some below the plane.



**Figure 10 - 21** Flat plane intersecting a triangle

The line of intersection between the triangular plane and the flat plane is automatically found and the overall volume is decomposed into simpler volumetric components.

Option 910 allows the volume to a datum level to be calculated. Alternating the datum level to accommodate a cut/fill balance can be derived iteratively by moving an estimate of the datum level. Specifying an amount of unsuitable cut varies the datum level to allow for some of the cut volume to be ignored.

Input

Graphics

IGPRIST.DAT, PRI002, PRI003

PRISM option details	Volume from triangulation
Define system parameters	Triangulation label
Define linear units	Boundary string label
Define string masking	Datum level
Volume from triangulation	Percent unsuitable
Volume from isopachyte	Hatching default (T)
Mean thickness of ISOS	
End PRISM	

Linemode

Minor option 910

- \* Field 1      Triangulation string label
  - Field 3      Boundary string (optional)
  - Field 4      Datum level
  - Field 7      % unsuitable. If zero, the result is average height which produces cut/fit balance.
- ◇ *Field 4 or field 7 must be coded, but not both.*
  - ◇ *If field 4 but not field 7 is coded, the true volume is calculated.*
  - ◇ *If field 7 but not field 4 is coded, the cut and fill balance is calculated.*

Example A Volume to a datum level

```

MOSS
PRISM, WASKERLEY TRIANG
910, TRIM, 4=25
999

MIN LEVEL           =           5.400
MAX LEVEL           =           48.000
BASE LEVEL          =           25.000
CUT VOLUME          =       200546.780
UNSUITABLE          =           0.000
FILL VOLUME         =       396241.847
    
```

**Example B Volume with % unsuitable cut**

```
MOSS
PRISM, WASKERLEY TRIANG
910, TRIM, 7=10
999

MIN LEVEL           =           5.400
MAX LEVEL           =           48.000
BASE LEVEL          =           22.102
CUT VOLUME          =       311697.752
UNSUITABLE          =           31169.775
FILL VOLUME         =       280527.970
```

**Minor option 911 Volume from isopachyte**

Minor option 911 will calculate the true volumetric difference between two surfaces for an ISOS triangulation. The cut and fill volumes will be separately derived.

Calculating the volumes for an isopachyte triangulation is an extension to that for a simple triangulation. The isopachyte triangulation is the combination of two triangulations whereby the triangles of one surface are totally reflected in the other. The 'level' associated with each vertex of the combined triangulation is actually a level difference from one surface to the other.

Because of the sophistication in the isopachyte algorithms the resulting triangulation may be thought of as a simple triangulation for which the 'level difference' of zero represents the intersection of the two surfaces.

Consequently calculating the volumes to an assumed level datum of zero provides the cut and fill volumes for an ISOS triangulation.

**Input**

## Graphics

IGPRIST.DAT, PRI002,mPRI004

PRISM options	Volume from isopachyte
System parameters	Triangulation label
Linear units	Boundary string label
String masking	Hatching default (T)
Volume from triangulation	
Volume from isopachyte	
Mean thickness of ISOS	
End PRISM	

## Linemode

**Minor option 911**

- \* Field 1      Isopachyte triangulation label.
- Field 3      Boundary string (optional)

## Example

## Volume from isopachyte

MOSS

PRISM, ISOPACHYTE TRIANG

911, TRIS

999

THE TRUE VOLUMETRIC DIFFERENCE BETWEEN THE TWO SURFACES

CUT VOLUME =            835.489

FILL VOLUME =           325.871

**Minor option 912    Mean thickness of ISOS triangulation**

Minor option 912 will calculate the mean thickness between two surfaces for an ISOS triangulation.

Following the same theory as for 910 and 911 the mean thickness for an ISOS triangulation is deduced by considering the ISOS triangulation as a simple triangulation, finding the cut/fill volumes and dividing by the overall area being considered.

**Input**

## Graphics

IGPRIST.DAT, PRI002, PRI005

PRISM options	Mean thickness of ISOS
System parameters	Triangulation label
Linear units	Boundary string label
String masking	
Volume from triangulation	
Volume from isopachyte	
Mean thickness of ISOS	
End PRISM	

## Linemode

**Minor option 912**

- \* Field 1 Isopachyte triangulation string.
- Field 3 Boundary string (optional).

## Example

## Mean thickness of an isopachyte triangulation

MOSS

PRISM, ISOPACHYTE TRIANG

912, TRIS

999

THE AVERAGE THICKNESS BETWEEN THE TWO SURFACES

```

AVERAGE THICKNESS      =      0.170
BALANCE VOLUME          =      620.782

```

# Chapter 11 Visualisation

## Visualisation

### Introduction to perspective views

The perspective options permit views to be taken of stored model information. Views of a model may be taken from any position and either simple wire line views or views in which the hidden lines of the view are suppressed may be produced.

The minor options allow the specification of the eye point and view point positions either as absolute coordinates or relative to existing model information. Photomontage facilities have been developed which permit the superimposition of a perspective picture onto an existing photograph.

Models to be viewed may contain any form of string information such as contours, ground survey strings, designed road detail, or sections extracted from any of these models.

The definition of the required view may be carried out in either interactive graphics or linemode. Any generated perspective view may be stored as a model in its own right and may then be edited or plotted using the other MOSS facilities. Often it is only required to produce a display of the results and a special feature has been introduced so that models may be regarded as temporary and they are retained solely for immediate plotting, thus avoiding unnecessary storage of model data.

◇ *VIEW uses the major option TRIANGLE generated triangulation.*

### Discussion of the use of perspective views in road design

One of the advantages of computerised design systems is the ability to produce perspective views of designed works. The power of modern computers allows the transformation of three dimensional design data into perspective views to assist with the assimilation of the design. MOSS's power to produce perspective views has been enhanced to include solid colour perspective views by major option VISUALISE and EPIC within the MOSS Visualisation system.

One possible reason for the lack of enthusiasm for perspective views is that in the past many views have been produced from a drivers view point and the results tend to be meaningless to anyone other than the professional designer. Such views can assist an engineer to assess the implications of a new design but are little help in making a qualitative assessment of the design of the scheme. Previously, the effort involved in producing perspective views early in the design process was often prohibitive in the absence of identification clues such as road markings, traffic signs, street

furniture etc. provided an incomplete picture, and the possible effects of shadows were necessarily ignored.

Thus drivers eye views are considered to be of little benefit in the design process and of less use for presenting a design to the public during public inquiries and public participation exercises which are assuming increasing importance. Much controversy concerns the selection of a route and the visual impact of a design on its surroundings. Traditional engineering drawings are not widely understood by the layman and small scale models are both difficult and costly to construct and to modify and are somewhat impractical for large projects.

An accepted way of presenting finished designs is with oblique aerial photography and it is probably in this direction that the value of perspective drawings can be best exploited. Oblique aerial photographs can show a finished scheme within the surrounding environment and have an immediate and instinctive appeal which suggests that if perspective views of complex interchanges were to be superimposed on to a photograph of the existing land form, a most effective and impressive method of scheme presentation would result. This method is now a reality and at public inquiries, "before" and "after" photographs can be presented and the most complex of schemes shown in their natural, colourful panorama. These photographs are complementary to the engineering drawings and of far greater use to the layman when trying to understand and visualise the full impact of a proposed project.

Oblique perspective views may be used as a design tool in their own right without recourse to the associated photographs and meaningful perspectives may be drawn as a continuous process from the original fixing of the horizontal and vertical design through to the completed design.

A difference between high level views and low level drivers eye views, involves the concept of suppressing hidden lines. Where a surface is viewed from a particular point those edges which cannot be seen because they are hidden either by the surface itself or some other object are known as hidden lines. The elimination of hidden lines involves a computing overhead over the production of a simple wire line view. For low level views quite a number of the design lines of a scheme are obstructed by the overall surface, but as the height of the view increases, so the number of hidden lines tend to decrease. Thus, meaningful views may be produced for oblique perspectives without removing hidden lines and the substantial reduction in computer processing makes this technique more attractive.

At the final design stage, for the proper appreciation of the view from a drivers position, a low level picture becomes more useful. This technique can help the assessment of bridge designs and embankment designs and assists with the evaluation of the sight line distances.

The discussion so far has concentrated on producing views of the original model data and sometimes these views do not give a real impression of the shape of the surface under consideration. This is particularly so in the case of ground survey models where many of the strings do not represent actual ground features but are merely infilling. In this and other similar cases,



various techniques have been developed to enhance the views in particular the taking of sections through the original model and superimposing them on to the view giving a more solid look.

The perspective options permit views to be taken of any stored model. Usually the model will be a ground model or a designed feature model, but impressive results have been achieved where the third dimension of the string is not label information, but some other parameter. For example, the third dimension could be population density. The general MOSS philosophy of requiring the first two dimensions of any string to have spatial coordinates is all that is needed to produce a perspective view.

### Calculation of the perspective transformation

The procedure for producing a perspective view involves transforming the coordinates of a model from the real cartesian system into a picture system. The complete transformation is built-up as a sequence of individual steps and these are :-

1. Move the origin of the real coordinate system so that it is based on the position from which the view is taken.
2. Rotate the coordinate system so that the y axis may be projected on to the line of sight.
3. Rotate the revised system until the z axis lies along the line of sight.
4. In this position the y axis will be found to be pointing downwards rather than upwards. This is reversed.
5. Sometimes with photomontage there is a small amount of "swing" so that the y axis is not pointing directly upwards but leans slightly to one side or the other.
6. The above 5 steps may all be combined to produce the revised eye coordinate system.
7. Having transformed the points in the model into the eye coordinate system, the resulting 3D model may be reduced to a 2D model by a simple proportioning exercise.

In the calculation of the perspective transformation the constituent variables are:-

PICDIS	the distance of the perspective plan from the eye.
THETA,BETA	two rotation angles.
XEYE,YEYE,ZEYE	the coordinates of the eye position.
SWING	a rotation angle to accommodate leaning of the picture.

In most cases (excepting photomontage) the amount of swing will be set equal to zero.

The picture distance (PICDIS) affects the scale of the view and usually a default value of 1.0 may be adopted.

In the simplest situation the coordinates of the eyepoint and the coordinates of a point towards which the viewer is looking are known. From these two sets of coordinates the two rotation angles are easily deduced and thus the easiest way to define a view is:

Define the coordinates where the viewer is standing.  
 Define the coordinates where the viewer is looking towards.  
 Define the distance in front of the eye that the picture will be held. (usually 1.0)

The definition of the actual coordinates need not in fact be as cartesian coordinates but may be referred to other detail contained within the model by using Standard Point Reference Data techniques. In this manner for example, the viewer may be defined as being located at a particular chainage, on a particular string, at a particular height above the level datum. This is explained more fully in the section on Data Preparation.

Thus the basic data requirements are simple. However there are occasions when this information, although not missing is not given explicitly, but is given in the form of points for which both the picture position and the real coordinate positions are known. The solution to this problem is known as the solution to the photomontage problem.

### The photomontage problem

Before the perspective transformation may be formulated the following variables need to be defined

- PICDIS                      the distance of the perspective plane from the eye.
- THETA, BETA              two rotation angles.
- XEYE, YEYE, ZEEYE      the coordinates of the eye position.
- SWING                      a rotation angle to accommodate leaning of the picture.

If the value of these parameters is known explicitly the perspective view may be drawn. However, occasionally some or all are unknown and need to be deduced from other information available. One such situation is when a photograph has been taken from a known position, but the direction of sight is not strictly defined. If, in this instance the two rotations and the picture distance could be deduced, an extremely useful technique becomes available whereby ground views of new bridges and embankments may be superimposed onto existing photographs to illustrate proposed schemes.

In some cases none of the variables are known, such as where a photograph of an area exists with some distinguishable detail but the position from which the photograph was taken is unknown.

Aerial photographs taken at an oblique angle usually fall into this latter category. The purpose of deriving the perspective transformation parameters from such a photograph is that a photograph can be taken of an existing situation and then a designed scheme may be superimposed upon it thereby giving an impression of the finished works.

The problem is solved by relating arbitrary points in the photograph to their actual grid position. Points chosen from photographs are those where the eastings, northings and levels can easily be obtained either from ordnance survey maps or from ground survey information if this is available. The best points to use are buildings, fence intersections, manholes or other similar distinct features. These points are then related to their position on the

photograph by superimposing a set of axes centrally on the photograph and scaling off either manually or with a digitiser the photographic coordinates.

For the semi-photomontage problem, where the eyepoint is known but the rotations and picture distance are unknown, there are four unknowns and for full photomontage where none of the viewing parameters are known there are seven unknowns. For each unknown there must be at least one constraint before the solution can be found.

Each point in the photograph which may be related to a point in real space provides in effect two constraints in that the 'x' of the photograph relates to the 'x' of real space whilst the 'y' of the photograph relates to the 'y' of real space. Hence at least two points are required for semi photomontage and four points are necessary for full photomontage. However since the solution is iterative and uses a least square technique, more than the minimum number of points may be given and a best solution is found. The advantage of this is that any errors caused by minor distortions in the production of the photograph or errors in the recording of the "photomontage" points, will be reduced to a minimum.

The solution is to estimate the various parameters and from these estimates to calculate the transferred picture point. The differences between the transformed point and the true picture point may be calculated, squared and summed. But taking successive estimates this "sum of squares of residuals" is minimised until it is sufficiently small to be acceptable.

An initial estimate of the unknown parameters is needed to begin the solution procedure and the routines within the option can usually calculate this initial guess for the data points given.

When the eyepoint is fixed (semi photomontage) the initial estimate is found by taking the two data points which are farthest apart on the X axis of the photograph and which lie to either side of the Y axis. This latter restriction prevents ill conditioning and the demand for a reasonable distribution of photomontage point helps prevent erroneous results.

A good 'scatter' of data points is probably more important in finding the initial estimate and thence the solution for full photomontage. For this estimate four points are necessary and the four points taken are those closest to each corner of the photograph. The concept of the solution is to find two parallel lines in the photograph. Because of the perspective transformation, the two lines are not parallel in real space but in fact emanate from the eye, and hence their intersection in plan view gives the eyepoint coordinates. Having got the eyepoint coordinates, the height from which the photograph was taken and the direction angles, may be deduced. The technique employs interpolation of the photograph which is carried through to the real space. Consequently there is inherent error in ignoring the foreshortening of the lower half plane and the corresponding lengthening of the upper half plane, and this is where one important element of approximation lies.

It should be stressed that for full photomontage a good distribution of points across the four quadrants of the photograph is essential to get a reasonable first estimate. However there are occasions, particularly with high level photography where distinct features are difficult if not impossible to locate and although the photograph covers a wide panorama the area of interest lies in only one or two quadrants. This makes it impossible to have a good scatter of data points. The remedy is to specify an approximate starting position which can readily be judged by eye by looking at the map and the picture. An alternative is to use a small scale plan with the photograph to get approximate points and then to give the solution for this data set as the first estimate for the precise data set.

### **Practical considerations for photomontage**

As the full and semi-photomontage options rely on the accurate definition of points on the original survey plan and on the photograph, the following notes should be considered when taking the photographs.

- Photographs should be as clear and sharp as possible bearing in mind that only a reflex type camera will allow accurate framing of the required details.
- Avoid over enlarging or the use of grainy films.
- Try to ensure that there is enough detail in the photograph to give at least one photomontage point in each quadrant. For this reason large expanses of sky, open fields and sea should be avoided. If this is not possible then ranging poles, buoys in open water or other items should be placed in the field of view and their positions surveyed in the field.

If a photograph has already been taken in which there is no useful detail in one or more quadrants it may be possible to solve the problem by moving the origin of the photograph in such a way that points of details appear in each of the four quadrants. An alternative approach is to give an approximate position for the eyepoint in the data.

- It is usually necessary to define the true co-ordinates of a photomontage feature (gate post, telegraph pole, corner of a building) where the feature intersects the ground surface, the photograph should therefore include the base of such features.
- To avoid confusion when preparing a photomontage of a developed area with a crowded background, a note should be made of the precise direction of the photograph along with prominent features included in the foreground.
- Successful photomontage in areas with wide open landscapes may be achieved with one of two methods –

### **Wide angle photography**

Wide angle lenses of 35 mm or 28 mm focal length on a single reflex camera should provide reasonable results, however, difficulties may be encountered when using shorter focal length lenses.

## Photographic mosaics

It is possible to build up landscape photomontage using photographic mosaics. The procedure is to produce a photomontage of a number of individual photographs separately and then combine them into a mosaic.

To accommodate the scaling parameters within the program and the error diagnostics, it is recommended practise to keep the photographic coordinates which define each photomontage point within the range +/-1.0, and to base the readings of the centre of the photograph. This in effect means that the photographic points are scaled off at a 1:1 scale so that when generating the plot at a later stage the use of a 1:1 scale will produce a direct overlay.

If a digitiser is used where an imperial unit of 1 inch is used then the relevant conversion factor is 0.0254

ie 1 inch = 0.0254 m.

This is again to allow for the subsequent plotting at a 1:1 scale to produce a direct overlay.

A good distribution of points over the full range of the photograph is important to ensure accuracy, and to obtain a first estimate. If no such distribution exists it is suggested that an approximate eyepoint position is given. This first eyepoint may be deduced either by visual inspection of the plan and photograph or by having an initial run with more coarse data.

The iterative technique begins from an initial estimate and continues until two successive iterations are sufficiently close together. The measure of this is the distance between the transformed points and the associated photographic points. These distances are squared and summed. If this sum of squared error is within a tolerance for two successive iterations the solution is assumed to have been reached. The default value for this tolerance is 0.000001  $((0.001)^2)$  but this may be changed by using the appropriate field on minor option 920.

Having reached the stage where two successive iterations are sufficiently close together, the least squares perspective transformation is printed out. The adequacy of the transformation itself is assessed by comparing the absolute errors of the transformed points in the direction of both axes of the photograph. The point search tolerance as defined by minor option 017 (default 0.01) is used in this comparison. If the difference between the defined point and the transformed point exceeds the point search tolerance a warning is given, if the difference exceeds five times the point search tolerance and error is given and the process stopped. The point search tolerance may be modified by recourse to minor option 017.

When the differences are large it may be difficult to distinguish the point or points which are in error. This is because each point can greatly affect the values of the parameters (ie the position of the eyepoint). The remedy, if careful checking of the data fails to identify any anomalies is to systematically remove the data points until the offending point is discovered.

Slight errors in the real coordinates will tend to have far less effect on the result than inconsistencies in the photograph coordinates.

Having once reached a satisfactory solution to the photomontage problem the parameters as printed in the output may be used as input values so that further perspectives may be generated directly without recourse to solving the problem again. This is particularly useful if various overlay models are being viewed.

### Generating a wire line view

Once the perspective transformation is derived, it becomes a simple matter for the defined model to be processed to produce a wire line view. Each string satisfying the mask table is taken in turn and the individual points are transformed and stored into the new model. Under the transformation the dimensions stored are:

XP – x coordinate of the perspective point.

YP – y coordinate of the perspective point.

ZP – depth from the eye of the point.

Negative coordinates are not allowed in a model so the stored (x,y) coordinates of the bottom left hand corner of the perspective are used as the origin, even though the perspective is calculated based on the centre.

It is interesting to note that all strings are transformed into three dimensional strings. For contours the perspective depth value will change from point to point and for section strings, interface strings, and master strings the dimensions above the third are not used in the transformation and indeed are meaningless within the context of the perspective transformation.

For most applications of the wire line technique there will be a distance from the eyepoint beyond which the view becomes meaningless, and a facility exists to restrict consideration of the model points to within this “depth”. The value of the depth may be modified but the default value is 1000.0.

Having generated the perspective model as a collection of 3D strings this model may itself be edited, reported, copied and plotted in its own right.

It needs to be emphasised that any two successive points whose plan distance is less than 0.001 apart, are considered coincident. This allows curve fitting to be used on the view and is also extremely important when it comes to hidden line removal, since the triangulation routines work in the (X,Y) plane. Consequently strings defining vertical drops such as bridge abutments, should be generated so that consecutive points are not coincident in plan.

### Hidden line removal

The drawing of a wire line can be of enormous value in visualising the real situation. The perspective effect is a strong aid in creating the illusion of depth which is an important factor in relating the different parts of the scene. One of the difficulties with such wire line representations of a surface is that all construction lines are visible and this can cause ambiguities for the simple examples and confusion for more complicated scenes.

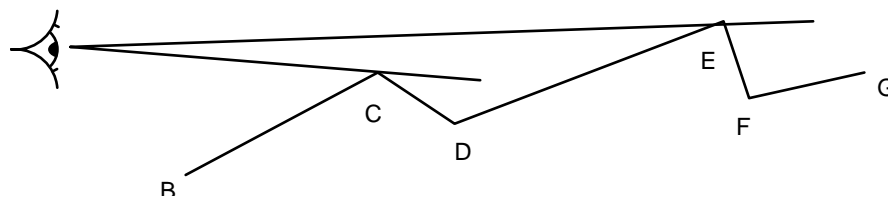
Various methods are available by which the ambiguities of the wire line view may be improved but the most successful is that of removing the hidden lines. When a surface is viewed from a particular point those edges which

cannot be seen because they are hidden either by the surface or some other object are known as hidden lines. Unfortunately the removal of these hidden lines requires a considerable amount of computation but for producing a finished product the extra work involved is often justifiable.

Eliminating hidden lines needs the model in a form which adequately represents the continuous surface. MOSS models stored as strings are unsuitable because although the strings making up the models define a continuous surface the spatial relationships between strings are usually unknown. For the majority of applications these relationships are unnecessary as information is extracted by a thorough geographic search as is the situation with cross-sections. However for the contouring and perspective options the spatial relationships are required in a more definitive form.

The most appropriate surface definition considers the surface as being constructed from a mosaic of triangular plates. What is unique to the MOSS concept is that because the strings define the surface each string line may be taken as being an edge of a surface triangle. This approach ensures that the influence of angular features, described by feature strings is not lost. The triangulation methodology is explained elsewhere but the algorithms developed efficiently create the most appropriate triangle based on their plan relationships, ignoring the level differences. A triangulation file is generated and each triangular plate in the file has three sides. Each side is in two triangles and for each side the adjacent triangle is recorded. These triangles form the basis from which those parts of strings which are hidden by the surface closer to the eye can be removed.

Removal of unnecessary or “hidden” lines is done in two stages. In the first stage the triangulation file is systematically processed and each side of each triangle is considered. A side is flagged as being totally invisible if it is not a string link or if it lies on a triangular plate whose face lies away from the eyepoint. Those sides which form ledges are also recorded. A “ledge” occurs where a forward facing triangle lies immediately in front of a backward facing triangle. The common side of the two triangles is recorded as being the ledge. For example in figure 11-1 points C and E would be contained within ledges.



**Figure 11 - 1 Hidden line removal – principles**

The second stage compares the list of ledges with those triangle sides still flagged as being visible. The ledges may either have no effect or they may completely or partially obscure any particular side. Each side is thus cancelled or flagged as being partially or totally visible.

Following the second stage process the strings of the original model are reconstituted by tracing them through the triangulation file and where breaks in the string are indicated (because of triangle sides being hidden), discontinuities produce the desired visual impression. These “ledges” are collected together in a string whose label is “EDGE” and consists of a series of discontinuous links.

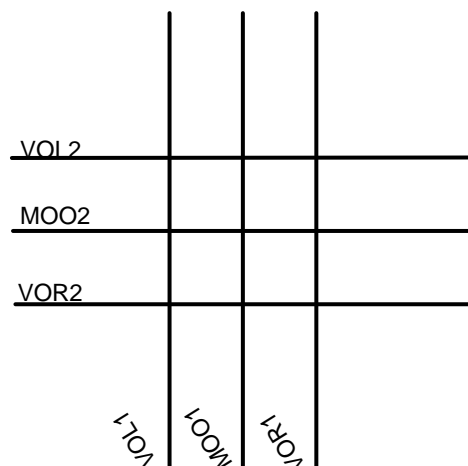
### Practical considerations for hidden line removal

It is important to appreciate the consequences of not having a continuous surface for the triangulation algorithms to operate on, from which the hidden lines are removed. The conditions necessary for an accurate triangulation are described in the Introduction to Model Surface generation. In areas such as bridge sites, problems related to vertical triangles will probably occur if certain these conditions are not met. The model may be modified to overcome these problems using major options DESIGN and EDIT. This is best explained by reference to an example.

When creating a model for VIEW, ensure that original model information remains unaffected by creating and using a copy.

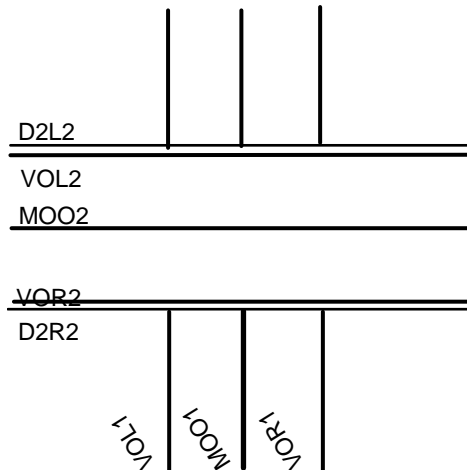
In Figure 11 - 2, strings VOL1, M001, and VOR1 go underneath strings VOL2, M002 and VOR2. The triangulation of this arrangement would probably create a meaningless jumble of triangles, caused by an attempt to create a surface that includes points on both the higher and lower sets of strings. To avoid this, some modifications should be made to the lower set of strings.

Method 1: Two strings labelled D2L2 and D2R2 should be generated using major option DESIGN. D2L2 should lie 0.01 to the left of VOL2 and D2R2 should lie 0.01 to the right of VOR2. Discontinuities may then be inserted into VOL1, M001, and VOR1 from where they intersect D2L2 to where they intersect D2R2. The resultant area will be as shown in Figure 11 - 3 and the triangulation will become meaningful. Once the discontinuities have been inserted into VOL1, MOO1 and VOR1, the strings D2L2 and D2R2 are redundant and may be deleted.



**Figure 11 - 2 Example - model before change**





**Figure 11 - 3 Example - model after change**

Method 2: Remove the upper strings eg the bridge deck. This will cause the triangulation to form along the abutments rather than across the lower surface. It will then be possible to take a view of this model and then overdraw a view of the bridge deck.

A second problem occurs when an incorrect level is attached to a point. In this instance the triangular plate so generated may either obscure what ought to be visible or make the reverse happen. The error is usually apparent from visual inspection of the area and is easily rectified by correcting the level and repeating the hidden line process.

### Hints

The area to be triangulated, and thus the area to be viewed, may be restricted by defining minimum and maximum coordinates, a boundary string, or a combination of both methods. This is fully described under "Introduction to Model Surface Generation".

The area to be triangulated may also be changed by varying the maximum depth parameter (Option 920). This considers all information beyond the defined value to be too far away to be seen and it is ignored.

It may occur to some users to employ the mask facility to restrict the amount of computation, particularly in areas where it is obvious that all of a string is hidden. This is a perfectly acceptable way of reducing processing but it can be dangerous as the triangulation so produced varies greatly with the strings included.

Where stream digitised contours make up part of the model, you may restrict the quantity of data by re-input of the raw data in a GENIO format with a suitable chord to arc optimisation tolerance.

Where a photomontage view is being produced it is advantageous to include all the control points selected from the photograph as a single string in the model to be viewed. When drawing the completed view this string may be drawn as symbols to aid matching the drawing and photograph.

## Plotting a perspective view

Having created a view model containing all the perspective strings the view model itself may be plotted using the MOSS plan plotting options. Perhaps the most important difference between the conventional plan plotting of a model and the plotting of a view model is in terms of scale. Normally the scale for plan plotting is 1 : 500 or 1 : 2500 whereas for perspectives the preferred scale is 1 : 1 or 1 : 2 because of the range of the picture coordinates.

All of the plan plotting facilities may be used but it should be remembered that special line and symbol types are applied at the plotting stage and will not be subject to the perspective transformation. The use of special line types such as dashed lines can, however, be very effective.

A 1 : 2 scale may sometimes be defined in preference to a 1 : 1 scale, in those instances where the width or height is specified as being larger than 1.0. This will overcome the difficulty of fitting the whole of the view onto one page.

For photomontage applications, provided the photo coordinates have been given actual metric values the appropriate scale will be 1 : 1 but if imperial measurements have been given the relevant scale will need to be 1 : 3.280840.

◇ *The drawing may appear to be at the wrong scale even when specifying 1:1. This is generally due to the model being larger than the area viewed in the photograph and showing a large amount of foreground.*

Because of the scale of the model produced the user may decide that the general convention, of assuming points closer than 0.001 to be coincident, is too coarse a tolerance. The tolerance may be modified when the generation of the view is initiated (option 923).

## Output

The printout details the coefficients of the equations which transform a point in real space into the picture plane. The procedure for carrying out the transformation is shown step by step, together with the constants of the picture and this enables individual points to be transformed by the user if needs be. The extents of the picture plane is reported in terms of minimum and maximum coordinates and these may assist in the definition of the bottom left coordinates for drawing.

Where photomontage facilities are used the perspective transformation details are preceded by a table showing the extent to which the photomontage points differ from the same points as derived by the chosen transformation. The interpretation of results contained in this table is discussed in the section entitled "Practical Considerations for Photomontage".

Invoking the hidden line removal option involves no increase in printout other than that produced by the triangulation routines.

All the relevant strings in a model are transformed and stored either in the defined perspective model or in a temporary model, allowing the viewed model to be subsequently plotted. The strings generated within the perspective model are all three dimensional since all dimension above the third become meaningless under the transformation. Each string carries its original label unless such a string label already exists when it will be renamed according to the procedure described in Chapter 2.

One extra string is created when hidden lines are suppressed and this string is labelled EDGE. The EDGE string tracks those horizons of the picture which are not themselves part of a string, and it consists of a series of discontinuities.

# Major option VIEW

Major option VIEW applies a perspective transformation to an existing model and creates a picture plane model suitable for viewing or plotting.

The features available in major option VIEW may be selected and operated from either interactive graphics or linemode. The approach used in graphics does not always parallel that used in linemode, consequently the documentation for the two modes is separate and in the following order -

- Graphics
- Linemode

## Major option VIEW - Graphics

## Access to major option VIEW

IGGENLT.DAT, GEN005

<b>Drawing Options</b>
DRAW Working Drawings
DRAW Contract Drawings
ENHANCE Drawings
Add annotation
CLIP drawings
LAYOUT
Drawing sheets
MACROSYMBOLS
Create/amend/store
VIEW
Perspective/Photo
VISUALISE
Prepare EPIC data
2DDXF
DPF conversion to DXF
NEW DPF Select DPF
NEW RPF Select RPF
REPORT
Models/strings/points

## Model for VIEW

IGVIEWT.DAT, VIE001, VIE002

Model for VIEW	VIEW option details
Model to be viewed	Define system parameters
Reference model	Define linear units
Triangulation ref model	Define string masking
Model to store view	Define VIEW parameters
	Eye and Target points
	Photomontage
	Create view
	End VIEW

When the model for VIEW menu has been completed, select Proceed to cause display of the other VIEW menus.

### Define system parameters

Selecting Define system parameters, Define linear units or Define string masking will result in the display of the appropriate Global minor option menu.

**Input**

IGVIEWT.DAT, VIE009?,VIE010

Define system parameters	Define string masking
Curve fitting status (T)	Mask label
Input coord notation (T)	Include/exclude/reset (T)
Angular input units (T)	
English/French design (T)	
Triangle error echo (T)	
Triangle FLAT/NOFL (T)	
French road type (T)	
Output coord notation (T)	
Angular output units (T)	
Survey station str label	

**Define VIEW parameters**

Selecting **View parameters** will allow you to set up the following -

**Input**

VIE002, VIE003

VIEW option detail:	Define VIEW parameters
Define system parameter:	Hidden lines removed (T)
Define linear units:	Triangulation label
Define string masking:	Picture distance
Define VIEW parameter:	Picture height
Eye and Target point:	Depth of view
Photomontage	Coincident pt. tolerance
Create view	Bottom left X
End VIEW	Y
	Iteration tolerance
	Correct to vertical (T)

◇ *Default values are provided for all entries except the triangulation label.*

- ◇ *If you respecify view parameters, any values previously changed remain until you exit from major option VIEW.*

Once the View parameters have been set up or the defaults accepted the EYE point and the TARGET point must be set up.

## Eye and target points

### Input

IGVIEWT.DAT, VIE002, VIE004

VIEW option details	Eye and Target points
Define system parameters	Eye point X
Define linear units	Y
Define string masking	Eye level
Define VIEW parameters	Target pt X
Eye and Target points	Y
Photomontage	Target level
Create view	Azimuth bearing
End VIEW	Vertical angle
	Angle of swing

**Azimuth bearing** of direction of view is measured clockwise from due North.

**Vertical angle** of direction of view is measured anti-clockwise from horizontal.

**Angle of swing** is measured clockwise from the vertical in the picture plane.

## Photomontage

### Input

If a semi-photomontage view is required, first define the EYE point, then select photomontage and complete the required details.

If a full photomontage view is required then select photomontage without first selecting the EYE point.

IGVIEWT.DAT, VIE002, VIE006

VIEW option details	Photomontage
Define system parameters	Point number
Define linear units	Point X
Define string masking	Y
Define VIEW parameters	Z
Eye and Target points	Photo X
Photomontage	Y
Create view	Eye estimate X
End VIEW	Y
	Z

When all the information has been input select 'Create view'.

### Create view

When you select 'Create View', the view is generated and displayed together with the 'View review' menu. It will remain until you make a selection from the menu.

### Input

IGVIEWT.DAT, VIE002, VIE007

VIEW option details	VIEW review
Define system parameters	Accept view
Define linear units	Respecify view
Define string masking	
Define VIEW parameters	
Eye and Target points	
Photomontage	
Create view	
End VIEW	



- ◇ *Accept view will cause the displayed model data to be saved as the 'Model to store view', and prompt for a name for saved DPF. When the save is complete you will be returned to the VIEW minor options menu.*
- ◇ *Respecify view will cause the displayed model data and DPF to be deleted and return you to the VIEW minor options menu.*
- ◇ *The line colours specified in the plan drawing are used.*
- ◇ *The EDGE string will be drawn in the IGMODE current colour. Any string not drawn in plan and not masked out of the VIEW will be drawn in the IGMODE default colour.*

## Major option VIEW - Linemode

The minor options available are as follows:

920	Definition of general viewing parameters
921	Definition of picture orientation
922	Definition of photomontage points
923	Production of a perspective view
924	Sketch facility

### String identification

The transformed strings are three dimensional, each element contains the picture plane coordinates and the distance of the point from the eye. The string labels are maintained unless a given label already exists in the picture plane model.

Hidden line removal is calculated using a stored triangulation which has been created using major option TRIANGLE. This allows the full set of trimming and subdividing options to be used when creating the triangulation.

Major option VIEW

Model 1	Model which is to be viewed.
Model 2	Model containing reference strings, if not in first model. Otherwise leave blank.

Major option VIEW

Model 3	Model for storing the resultant perspective view. If blank, a temporary model is generated.
Model 4	Model containing stored triangulation. This model is only required when performing hidden line removal.

### Global minor options

The global options 000, 017, 019, 900 and 999 may be used with major option VIEW.

The 017 option may be used to change the default method of input or output for angular information; to redefine the station string reference or to modify the point search tolerance.

The point search tolerance is also used in photomontage for comparisons between photographic points and their true position.

The 019 option is used to provide inclusive and exclusive masks.

## Minor option 920 Definition of viewing parameters

Various parameters govern the size of the viewed area. The default values will normally be most appropriate but these may be changed.

The resulting picture will usually be viewed as being perpendicular to the line of sight but it may be projected onto the vertical plane.

Where the picture orientation is being derived by photomontage a tolerance is used to determine when the iterative process should stop. The iterative technique begins from an initial estimate and continues until two successive iterations are sufficiently close together. These distances are squared and summed. If this sum of the squared error is within a tolerance for two successive iterations, the solution is assumed to have been reached. The default value of this tolerance is 0.000001 but for coarse data this may need to be relaxed.

A previously stored triangulation created by major option TRIANGLE must be specified if hidden line removal is required.

### Input

#### Minor option 920

Field 1	If picture is to be corrected to the vertical code TILT
Field 2	If hidden lines are to be suppressed code HIDE
Field 3	Triangulation label of stored triangulation for use in hidden line removal. If hidden line removal is not required, leave blank.
Field 4	Iteration tolerance for photomontage, default value 0.000001
Field 5 & 6	Coordinates of bottom left hand corner of picture, default values 1.0,1.0
Field 7	Distance from eye that picture will be viewed, default value 1.0
Field 8	Width of picture, default 1.0
Field 9	Height of picture, default value 1.0
Field 10	Depth of picture, beyond which nothing can be seen, default value 1000.0

## Minor option 921 Definition of picture orientation

The perspective transformation is based on seven parameters and these are the (x,y,z) position of the eyepoint, three rotations about the eyepoint position and the distance of the picture from the eye. In the simplest situation these parameters are known explicitly by their value, or may be

easily deduced from the known position of the eyepoint and a target to which the view is directed.

When semi photomontage is required the eyepoint is defined by recourse to minor option 921 but no minor option 921 specifies the target point. Instead several minor option 922's relate a point of real coordinates with its associated picture coordinates. At least two such photomontage points are necessary before the target parameters may be deduced, although four photomontage points with one in each quadrant of the photograph is likely to produce a better result indicated by a smaller transformation error.

Full photomontage demands the derivation of all seven parameters and these are derived by defining at least four photomontage points with minor option 922 records, but preferably seven or eight photomontage points with at least one in each quadrant a better result is likely to be obtained.

The absence of a 921 minor option defining the target is sufficient to invoke the semi photomontage facility whilst the absence of a 921 defining both the target and the eyepoint will invoke full photomontage.

If both the target and eyepoint are unknown the algorithm must have a first estimate of the eye position from which to begin. The routines can find this first estimate but if an approximate position can be given this may be done by defining the eyepoint in the normal way but indicating that it is only an estimate on the 921 record.

The actual coordinates of the eyepoint or viewpoint need not be given as coordinates but may be defined relative to either designed features or survey station points.

## Input

### Minor option 921

Field 3	Code EYE if the position of the eye is being defined Code TARG if the position of the target is being defined
Field 4	Code -1.0 if the point being defined is only an estimate

### Specification in relation to a set of coordinates

- \* Field 5, 6 & 7 Code to easting, northing and level of either the eyepoint or the target point

### Specification in relation to a reference string

- \* Field 1 Reference string label
- \* Field 5 & 6 SPRD for the point on the reference string.
- Field 8 Offset of defined point normal to point on the reference string.
- Field 9 Offset of defined point tangential to the point on the reference string.
- Field 10 Vertical offset of the defined point relative to the point on the reference string.

**Specification in relation to a survey station**

- \* Field 2      Station label.
- Field 10      Vertical offset to be applied to the level of the station point.

**Specification of target point in relation to angle of view**

(This may only be used in defining the target parameters. The default angular measure for input is degrees and decimal degrees.)

- Field 8      Azimuth bearing of direction of view, measured clockwise from due North.
- Field 9      Vertical angle of direction of view, measured anti-clockwise from horizontal.
- Field 10     Angle of swing measured clockwise from the vertical in the picture plane.

## Minor option 922    Definition of photomontage points

This minor option is used to relate real coordinates with their associated picture coordinate points.

Up to 20 photomontage points may be defined, but all must be defined together ie once another minor option is used no more photomontage points may be defined.

All photographic coordinates are based on axes central to the photograph and at right angles to the side of the photograph

Much greater care must be taken in defining real and picture coordinates in the foreground as these have much greater effect on the perspective transformation than those in the background.

In order to facilitate the accurate overlaying of the perspective view on the photograph, the photomontage points may be edited into the model to be viewed as a point string, so that when the string is plotted using standard detail interpretation the points will be shown in their correctly transformed position.

### Input

**Minor option 922**

- \* Field 8 & 9    Code the picture coordinates of the point.

**Specification in relation to a set of coordinates**

- \* Field 5, 6 & 7 Easting, northing and level of the point

**Specification in relation to a reference string**

This alternative will be used to identify distinct features in the photograph, such as corners of buildings, which have been previously surveyed.

- \* Field 1      Reference string label
- \* Field 5 & 6    SPRD for the point on the reference string.

**Specification in relation to a survey station**

- \* Field 2          Station label
- Field 10        Vertical offset to be applied to the level of the station point.

**Minor option 923    Production of perspective view**

This minor option initiates the generation of the perspective view and must always be used. If a mask table has been defined, only those strings satisfying the mask label will be included.

Within MOSS two points are usually considered coincident if they are within 0.001 of each other. Because the subsequent plotting of the perspective view will normally use a 1 : 1 scale rather than a 1 : 500 scale, a facility has been incorporated whereby this tolerance may be reduced, allowing the plotting to be of a very high order.

**Input**

Minor option 923

**Wire line perspectives**

- Field 4          Coincident point tolerance (default value 0.0001)

**Minor option 924    Sketch facility**

This option permits points not held in a string within a stored model to be stored directly into a string within the viewed model. The implication is that a view may be created independently of stored model information. There are two major uses of this option.

The first major use concerns lines which lie in the vertical plane. One of the concepts of MOSS is that all points must be visible in plan view and if their coordinates are equal in easting and northing they are considered identical. This can cause particular difficulty if the facilities of MOSS are required to be used for such things as visualising traffic signs. Because the sketch facility does not use stored information the described difficulty is overcome.

**Input**

Minor option 924

- Field 2          Specify CONT if the first point is to be joined by a line to the last point on the previous 924 option.
- \* Field 3        String to which points will be added.
- Field 4          Coincident point tolerance (default value 0.001)  
(See the equivalent description for minor option 923)
- \* Field 5        )
- \* Field 6        )    Coordinates of first point.
- \* Field 7        )

Field 8 )

Field 9 ) Coordinates of second point.

Field 10 )

If the string specified in field 3 already exists the points will be added to it. In any one run the first 924 option must not have 'CONT' defined in field 2, since there is no previous 924 option to carry on from. Where 'CONT' is not defined a discontinuity is placed within the string unless the existing point in the string and the new point are identical.

It should be noted that when points are joined together the result is a superimposed wire line framework having no regard to hidden line removal.

## Examples

The examples illustrate the facilities available.

All the following examples will produce a similar, though not always identical view. For ease of use various strings have been masked out. The default depth value is only 1000.0 and this needs to be increased to 10000.0 on the 920 option, because of the distance of the eyepoint from the model detail, as the Thornbrough design is an imperial design.

### Simple perspective

The following data defines both the eyepoint and the target point as coordinates.

```
MOSS,SIMPLE PERSPECTIVE
VIEW,THORNBROUGH INTERCHANGE
VIEW
019,00,4=-1.0
019,P,4=-1.0
019,B,4=-1.0
920,10=100000.0
921,3=EYE,5=3944.812,37059.541,1573.315
921,3=TARG,5=3863.497,36083.382,1372.065
923
999
```

### Photomontage : unknown target

Whereas the eyepoint is defined explicitly, the target point is not and must be found by least squares calculation.

```
MOSS,SEMI PHOTOMONTAGE
VIEW,THORNBROUGH INTERCHANGE
VIEW
019,00,4=-1.0
019,P,4=-1.0
019,B,4=-1.0
019,4=1.0
920,10=10000.0
921,3=EYE,5=3944.812,37059.541,1573.315
922,5=3090.0,29545.0,128.0,0.0272,0.0128
922,5=3020.0,31590.0,131.0,0.0737,-0.0477
922,5=2970.0,28897.0,136.0,0.0314,0.0263
922,5=3017.0,29983.0,127.0,0.0415,0.0027
922,5=3080.0,29810.0,126.0,0.0314,0.0065
922,5=3433.0,31452.0,130.0,0.0071,-0.0433
922,5=3587.0,30983.0,131.0,-0.0213,-0.0268
922,5=3870.0,28700.0,125.0,-0.0653,0.0271
922,5=4040.0,27980.0,125.0,-0.0843,0.0391
923
999
```

**Photomontage : unknown eyepoint, unknown target.**

In the following example neither the eyepoint or the target point is given and these will be estimated by recourse to the photomontage points available.

```
MOSS,SEMI PHOTOMONTAGE
VIEW,THORNBROUGH INTERCHANGE
VIEW
019,00,4=-1.0
019,P,4=-1.0
019,B,4=-1.0
019,4=1.0
920,10=10000.0
922,5=3090.0,29545.0,128.0,0.0272,0.0128
922,5=3020.0,31590.0,131.0,0.0737,-0.0477
922,5=2970.0,28897.0,136.0,0.0314,0.0263
922,5=3017.0,29983.0,127.0,0.0415,0.0027
922,5=3080.0,29810.0,126.0,0.0314,0.0065
922,5=3433.0,31452.0,130.0,0.0071,-0.0433
922,5=3587.0,30983.0,131.0,-0.0213,-0.0268
922,5=3870.0,28700.0,125.0,-0.0653,0.0271
922,5=4040.0,27980.0,125.0,-0.0843,0.0391
923
999
```

```
MOSS FULL PHOTOMONTAGE
VIEW NEW THORNBROUGH
VIEW
01900 -1
019P -1
019B -1
019 1
920 10000
922 3090.0 29545.0 128.0 0.0272 0.0128
922 3020.0 31590.0 131.0 0.0737 -0.0477
922 2970.0 28897.0 136.0 0.0314 0.0263
922 3017.0 29983.0 127.0 0.0415 0.0027
922 3080.0 29810.0 126.0 0.0314 0.0065
922 3433.0 31452.0 130.0 0.0071 -0.0433
922 3587.0 30983.0 131.0 -0.0213 -0.0268
922 3870.0 28700.0 125.0 -0.0653 0.0271
922 4040.0 27980.0 125.0 -0.0843 0.0391
923
```

```
LEAST SQUARES PERSPECTIVE TRANSFORMATION
-----REAL COORDINATES----- --PHOTO COORDS-- -TRANSFORMATION ---ERRORS----
      XR      YR      ZR      LXP      LYP      LXT      LYT      EX      EY
1  3090.0  29545.0  128.00  0.027  0.013  0.027  0.012  0.001  0.000
2  3020.0  31590.0  131.00  0.074 -0.048  0.074 -0.047 -0.000 -0.001
3  2970.0  28897.0  136.00  0.031  0.026  0.032  0.027 -0.000 -0.000
4  3017.0  29983.0  127.00  0.042  0.003  0.042  0.002 -0.000  0.000
5  3080.0  29810.0  126.00  0.031  0.007  0.031  0.006 -0.000  0.000
6  3433.0  31452.0  130.00  0.007 -0.043  0.007 -0.043  0.000  0.000
7  3587.0  30983.0  131.00 -0.021 -0.027 -0.021 -0.027 -0.000  0.000
8  3870.0  28700.0  125.00 -0.065  0.027 -0.066  0.027  0.001 -0.000
9  4040.0  27980.0  125.00 -0.084  0.039 -0.084  0.039 -0.001 -0.000
```

```
STANDARD ERROR OF TRANSFORMATION 0.000 0.000
```

```
THE PERSPECTIVE TRANSFORMATION IS :-
XE = (-0.996495 * XD ) + ( 0.083605 * YD ) + (-0.002891 * ZD )
YE = (-0.019648 * XD ) + (-0.200309 * YD ) + ( 0.979536 * ZD )
ZE = (-0.081315 * XD ) + (-0.976159 * YD ) + (-0.201250 * ZD )
```

```
LXP = ( XE / ZE ) * PICDIS
LYP = ( YE / ZE ) * PICDIS
```

```
XP = LXP + WIDTH + XORGIN
YP = LYP + HEIGHT+ YORGIN
```

```
WHERE      XD = XR-XEYE , YD = YR-YEYE , ZD = ZR-ZEYE .
           XEYE, YEYE, ZEYE ARE EYEPOINT COORDINATES .
           ( XR, YR, ZR ) ARE REAL COORDINATES .
           ( XE, YE, ZE ) ARE EYE COORDINATES .
```



( LXP, LYP ) ARE LOCAL PHOTO COORDINATES.  
( XP, YP ) ARE VIEW MODEL COORDINATES.  
(XORGIN,YORGIN)ARE BOTTOM LEFT COORDINATES.

THE CONSTANTS OF THE PICTURE ARE :-

COORDS. OF EYEPOINT            3944.812            37059.541            1573.315  
NOTIONAL TARGET                3863.497            36083.382            1372.065

DIRECTION ANGLES  
AZIMUTH BEARING                184.76181  
VERTICAL ANGLE                 348.38995  
ANGLE OF SWING                 0.16912

PICDIS FROM EYE                0.900  
COORDS. OF BOTTOM LEFT         1.000            1.000

WIDTH OF VIEW                 1.000  
HEIGHT OF VIEW                1.000  
DEPTH OF VIEW                 10000.000

VIEW MODEL - MINIMUM AND MAXIMUM COORDINATES

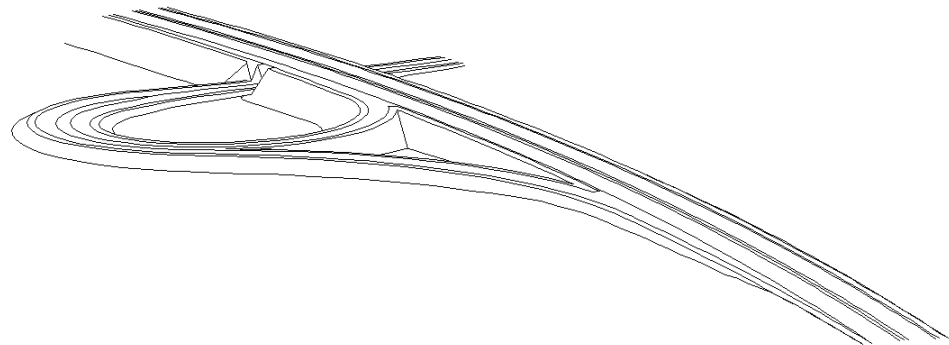
X-MIN	Y-MIN	X-MAX	Y-MAX
1.933	1.974	2.057	2.019

999

## Hidden lines removed

Having proved the photomontage derivation of the viewing parameters to be acceptable, hidden lines may be removed. To ensure the overlay onto the photograph remains exact without using the photomontage points again it is best to define the target in terms of the angles of view, which are given the output of the transformation. these angles may be defined in whichever way the user requires though degrees and decimal degrees are the defaults and are used in this example. The picture distance must also be defined.

```
MOSS,HIDDEN LINE REMOVAL  
VIEW, THORNBROUGH INTERCHANGE  
VIEW, THORNBROUGH VIEW, THORNBROUGH TRIANGLES  
019,00,4=-1.0  
019,P,4=-1.0  
019,B,4=-1.0  
019,4=1.0  
920,2=HIDE,3=TRIA,7=900,10=10000.0  
921,3=EYE,5=3944.812,37059.541,1573.315  
921,3=TARG,8=184.76181,348.38995,0.16912  
923  
999
```



**Figure 11 - 4 View - Hidden lines removed**

## Drivers eye view

A drivers eye view may be generated by specifying the eyepoint in relation to designed strings. In the example which follows it should be remembered that the Thornbrough design is an imperial design.

```
MOSS,DRIVERS EYE VIEW  
VIEW,THORNBROUGH INTERCHANGE  
VIEW,THORNBROUGH VIEW,THORNBROUGH TRIANGLES  
019,00,4=-1.0  
019,P,4=-1.0  
019,B,4=-1.0  
920,2=HIDE,3=TRIA,10=10000.0  
921,M003,3=EYE,5=3900.0,8=-22.5,10=3.5  
921,M003,3=TARG,5=4900.0,8=-22.5  
923  
999
```



Figure 11 - 5 View - Drivers eye view

### Contour data

There is no reason why any type of model should not be viewed (except triangulation and drainage models) and indeed no reason why a model generated from another model should not be viewed. For instance in the examples above it may have been deemed appropriate that the square grid model should be contoured. These contours may themselves be viewed thereby giving a different visual impression.

### Bridge structures

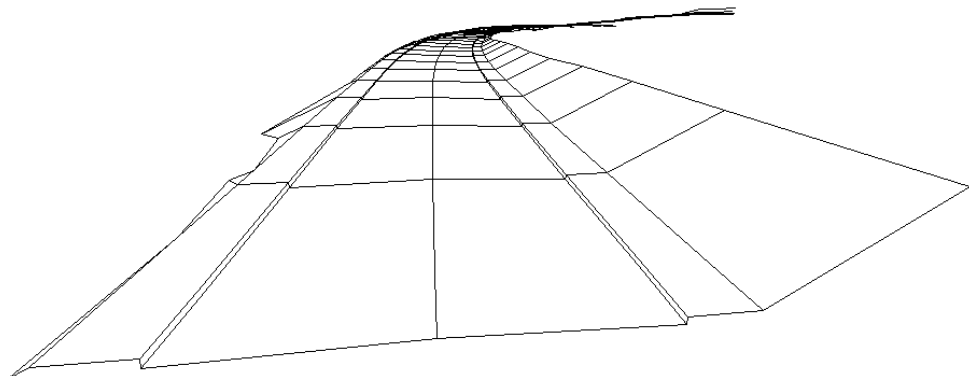
The design of bridges involves the use of finite element technique and often the meshes set up for the analysis need to be checked to ensure the data is consistent. This is best done by plotting and many programs incorporate such a feature. However it is not difficult should views from different points be desired, to generate data (again using GENIO) from the member and node incidences, so that perspectives of the bridge structure may be drawn.

### Ground survey data

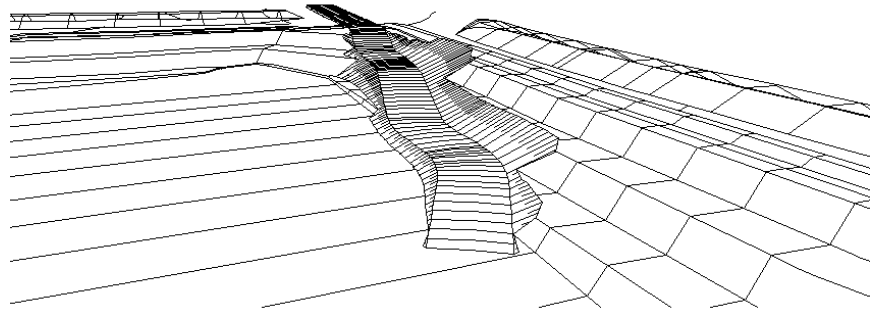
Particularly in the verification of photomontage detail it is useful to plot out the view of existing ground detail. This not only allows good orientation of the viewer to appreciate the design implications but also enables any gross errors in level and plan detail to be immediately recognised.

### Use of sections to enhance views

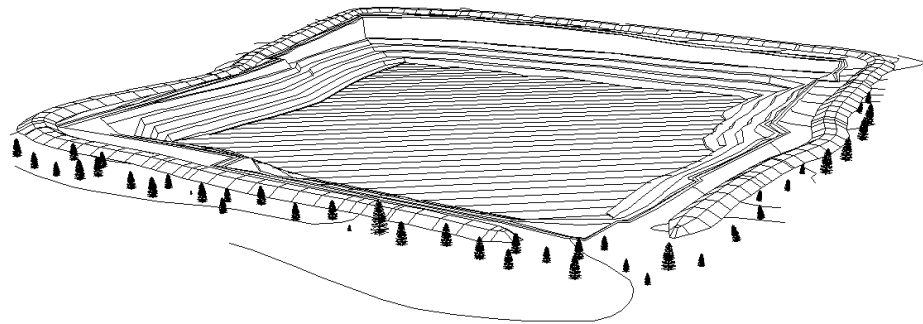
Sections taken through all or part of a model can be transformed and added to the picture plane model. Examples are shown below.



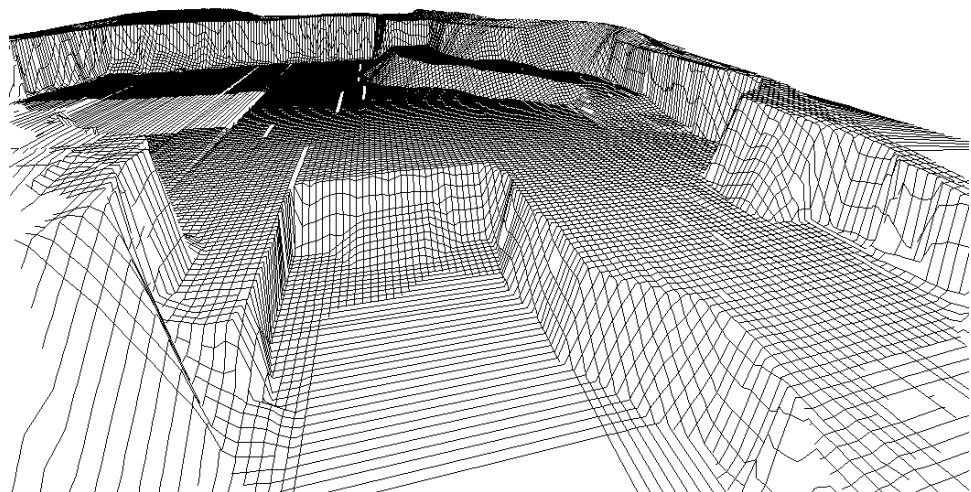
**Figure 11 - 6 Example - proposed road improvement**



**Figure 11 - 7 Example - Mining**



**Figure 11 - 8 Example - Proposed quarry**



**Figure 11 - 9 Example - Waste tip**

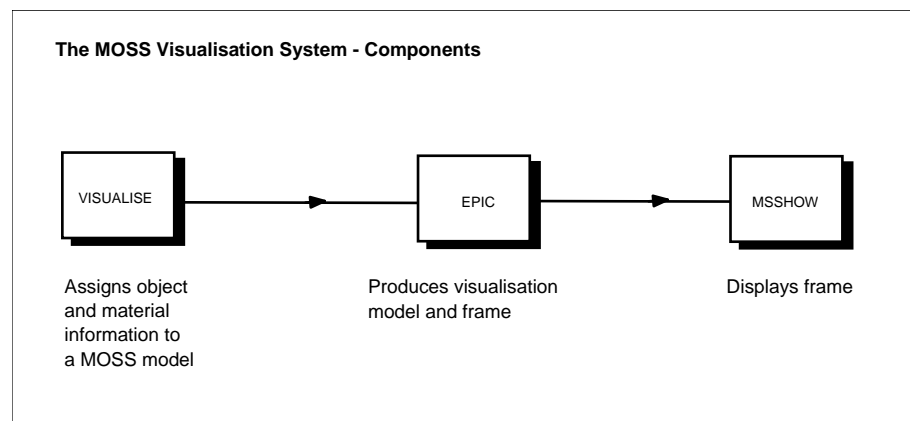
# Major option VISUALISE

## Introduction to the MOSS Visualisation System

The MOSS Visualisation System is used to produce solid colour perspective views of a MOSS design. Views can be taken from anywhere within the model, in any direction. Objects such as trees, hedges and lampposts may be placed in the model giving a high degree of realism to a proposed design. Views can be stored separately as 'frames' and used for a variety of purposes such as checking the visual appearance of proposed designs. They can also be printed for presentation at public meetings, planning enquiries and funding campaigns.

The MOSS Visualisation System comprises:

- MOSS major option VISUALISE
- EPIC
- MSSHOW

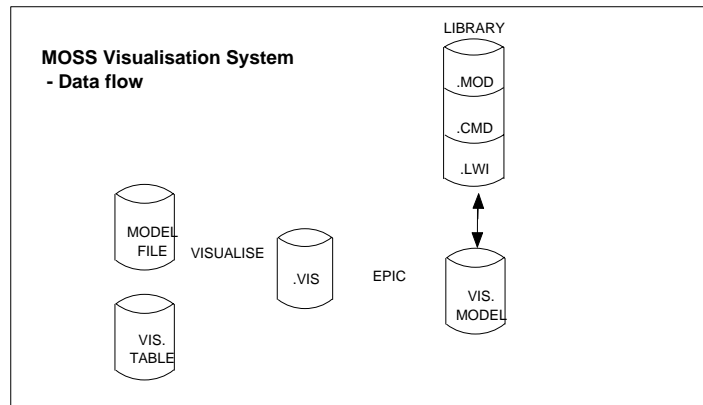


**Figure 11 - 10 The components of the MOSS Visualisation System**

## VISUALISE

Within MOSS, major option VISUALISE allows you to assign object and material detail to strings and triangles selected from the MOSS model file. A list of available objects and materials is held in a 'visualisation table'. This information is then output to the visualisation file.

## EPIC



**Figure 11 - 11 The MOSS Visualisation System data flow**

EPIC is the solid modelling and animation component of the MOSS Visualisation System. EPIC's powerful instruction set can be used to enhance the visualisation in various ways. Operations which may be carried out include:

- Shading and lighting changes
- Modification of eye and target points

## MSSHOW

MSSHOW is a standalone program which displays stored frames. They can be shown one at a time or replayed in a sequence without having to use the main visualisation program.

For further details of MSSHOW and its operation, refer to Chapter 14.

## Description of operation

An EPIC perspective view can be produced in one or two stages:

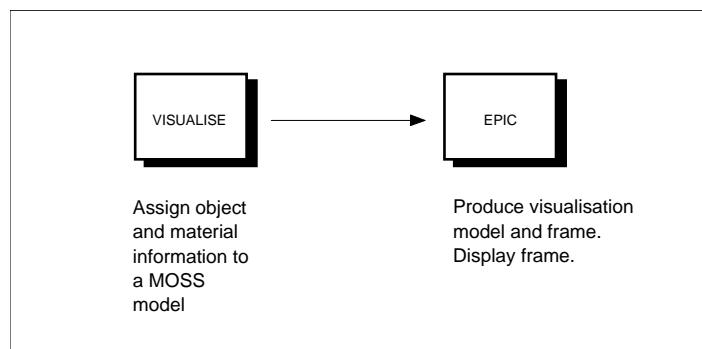
- The first stage creates an EPIC visualisation model and frame.
- The optional second stage enhances the visualisation model and produces additional frames.

### Creating a visualisation model and frame

To create a visualisation model and frame, you carry out the following operations:

- Enter MOSS with the model file containing the models from which you wish to construct the visualisation model.
- Select major option VISUALISE

- Specify the name of a string model. This model contains strings which define the position and/or orientation of objects which are to be included in the EPIC visualisation model.
- Specify the name of a triangle model. This model is created by triangulating the original model using major option TRIANGLE.
- Specify the name of the EPIC Data Store. This is a reserved model in the model file used for storing visualisation information.
- Using the VISUALISE menu options, assign objects such as lamp posts, road markings, hedges to selected strings from the string model. The list of available objects is stored in the visualisation table. The geometric properties of the objects are stored in the object library.
- Group triangles from the triangle model into separate surfaces such as roads, fields, rivers and pavements.
- Assign materials to the surfaces defined as triangle groups.
- Specify the eye and target coordinates.
- Save the information in a visualisation (.VIS) file.
- Invoke EPIC by selecting MSEPIC.
- Create a new visualisation model.
- Save a frame.



**Figure 11 - 12 Creating a visualisation model and frame**

**Further documentation**

For further details about using EPIC, refer to the EPIC User Guide.

**Major option VISUALISE**

VISUALISE is used to assign object and material information to existing models and then to produce a file containing this data for processing by the MOSS Visualisation System.



### Object strings and triangulations

Strings are used to define the position and direction of assigned objects. They are usually kept separate from both the model to be viewed and the triangulation model so that they may be altered to suit EPIC without fear of changing the original design.

Triangulations produced by major option TRIANGLE map the surface of a model. You may use VISUALISE to assign a material to groups of these triangles so that EPIC can apply appropriate colour and texture effects over the model surface.

### EPIC Data Store

The EPIC Data Store (EDS) is a reserved model in the model file in which visualisation information is stored. It is used to hold the object and material assignments made to strings and triangles respectively using major option VISUALISE.

Coordinate data for the strings and triangles used is not held in the EDS, but in the string and triangle models. However, reference is made to this data from the EDS, so if a string or triangle group is deleted or renamed then it cannot be processed by VISUALISE for inclusion in the visualisation file.

In addition, once an assignment has been included in the visualisation file, it is flagged in the EDS so that it is not included twice.

### Visualisation table

The visualisation table VISTAB.DAT is a text file containing a complete list of valid objects and materials which can be assigned using major option VISUALISE. The table comprises the following object and material types:

Type	Object/Material	Example
0	Material	Concrete, grass
1	Flightpath	Eye and target movement
2	One point object	Flagpole
3	Two point object	Lamppost
4	Swept object	Wall, hedge
5	Dashed object	Road centreline
6	Compound object	Signpost, fence

Parameters used by EPIC are stored in the visualisation table for each object and material.

### Types of object

A point object is an object which is repeated at regular intervals along a string. If it is important that the object faces a particular direction, ie, that the object is orientated correctly, two points on a string are required for each instance of an object. The first point defines the position of the object and the second point defines its orientation, ie, an instance of the object is placed at every other string point and points towards its neighbouring point. This type of object is known as a two point object.

For point objects with no particular orientation, only one point is required for each instance of an object. This point defines the object's position and so an instance of the object is placed at every string point. This type of object is known as a one point object.

A swept object is an object which is formed by sweeping a profile along a string to produce a feature such as a hedge or wall . A dashed object is produced in a similar fashion but is broken at pre-defined intervals. This does not, however, depend upon the continuity of the string itself; discontinuities and null levels in strings are ignored. A road centreline may be created using a dashed object.

A compound object may comprise both point, swept and dashed objects. For example, a fence can be made up of posts (one point objects) and rails (swept objects).

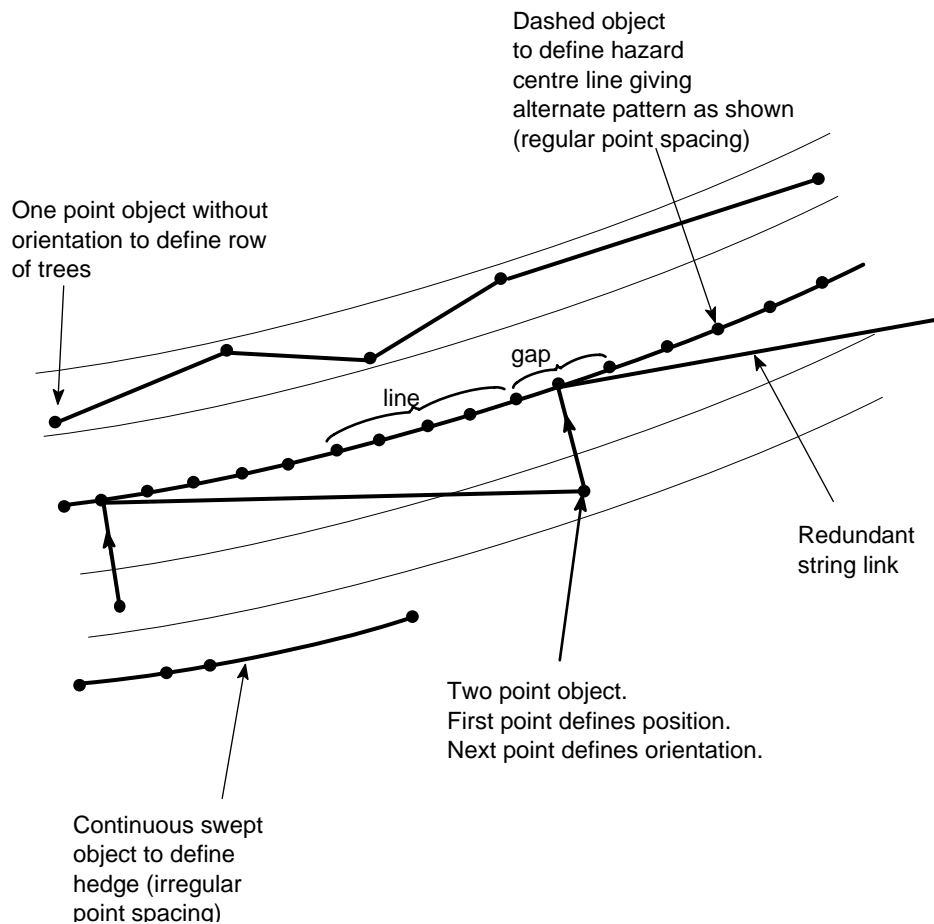


Figure 11 - 13 Assigning point and swept objects

## Access to major option VISUALISE

(VISUALISE may only be accessed via graphics mode)

IGENLT.DAT, GEN005

Drawing Options
DRAW Working Drawings
DRAW Contract Drawings
ENHANCE Drawings
Add annotation
CLIP drawings
LAYOUT
Drawing sheets
MACROSYMBOLS
Create/amend/store
VIEW
Perspective/Photo
VISUALISE
Prepare EPIC data
2DDXF
DPF conversion to DXF
NEW DPF Select DPF
NEW RPF Select RPF
REPORT
Models/strings/points

## Models for EPIC

IGVISUT.DAT, VIS001

Models for EPIC
String model
Triangle model
EPIC Data Store

**String model** is the name of the main model containing the strings to be used for assigning objects.

**Triangle model** is the name of the model containing the triangulation to be used for surface definition in the visualisation.

◇ *The triangle model must have been produced using major option TRIANGLE.*

**EPIC Data Store** is the name of the model within the model file which is used for storing visualisation information.

## VISUALISE options

IGVISUT.DAT, VIS048

<b>VISUALISE option:</b>
<b>Change models</b>
<b>Group triangles</b>
<b>Make assignments</b>
<b>Review assignment:</b>
<b>Define eye and targe</b>
<b>Clear visualisator</b>
<b>EPIC Data Store repor</b>
<b>Submit EPIC dat:</b>
<b>Exit VISUALISE</b>

**Change models** invokes the model selection menu so that the models used for visualisation may be reselected. See 'Models for EPIC' for further details.

**Group triangles** allows you to create triangle groups within a triangulation so that you can apply a different material to each group.

**Make assignments** allows you to add object and material information to an existing model and store this information in the EPIC Data Store.

**Review assignments** allows you to review the object and material assignments which have already been made and disable or delete those which are no longer required.

**Define eye and target** allows you to specify the eye and target coordinates.

**Clear visualisation** deletes all the assignments in the EPIC Data Store. It also clears the eye and target coordinates, frame number and shading type.

**EPIC Data Store report** produces a report containing all the details of the visualisation including the assignments which have been made.

**Submit EPIC data** allows you to create a visualisation file or to create a frame and display it via MSEPIC.

## Group triangles

Triangles from the triangle model may be grouped together and labelled so that different materials may be assigned to different parts of a surface. In this way, complex scenes can be created showing a wide range of natural and man-made materials.

Triangles for grouping may be defined by a boundary string or by seeding. Seeding groups all the triangles in an area contained wholly within continuous strings used to create a triangulation. Where the strings are not continuous, the grouping spills through any gap and continues until a continuous string boundary is found.

**IGVISUT.DAT, VIS048, VIS044**

<b>VISUALISE options</b>	<b>Group triangles</b>
<b>Change models</b>	<b>Group triangles by seeding</b>
<b>Group triangles</b>	<b>Group individual triangles</b>
<b>Make assignments</b>	<b>Reset group codes</b>
<b>Review assignments</b>	
<b>Define eye and target</b>	
<b>Clear visualisation</b>	
<b>EPIC Data Store report</b>	
<b>Submit EPIC data</b>	
<b>Exit VISUALISE</b>	

## Group triangles by seeding

IGVISUT.DAT, VIS044, VIS016

Group triangles	Group triangles by seeding
Group triangles by seeding	Triangulation string label
Group individual triangles	Group code
Reset group codes	Dummy link creation No
	Define string masking No
	Link tolerance 0.01
	First triangle
	Boundary string label
	Seed string label
	Hatching switch (T)
	Show ungrouped triangles

**Triangulation string label** is the name of the triangle string to be used for grouping, and may be picked from the screen or entered via the keyboard.

**Group code** is the four character name of the triangle group being formed, and is entered via the keyboard. The group code will be assigned to all the selected triangles when the grouping is accepted.

**String masking** can be used so that selected strings are ignored by the seeding process.

**Dummy link creation** enables you to prevent seeding spilling out of a desired area.

The **link tolerance** is the minimum length a triangle side can be without being a dummy link; in other words, triangle sides shorter than the link tolerance are not considered for further seeding. See 'Dummy links' for further details.

Triangles for grouping may be defined by a boundary string or by choosing a first triangle.

Selecting **first triangle** will group all the triangles subject to the following conditions:

- One or more of a triangle's sides is coincident with those of the first triangle or a triangle already seeded in the group.
- If a side of a triangle includes any string link used to create the triangulation, the side may not be considered for further seeding.
- Null triangles (ie, those with a level of -999 on any vertex) may not be seeded.

Selecting **boundary string** will group all triangles contained within the boundary string.

Selecting **seed string label** allows you to group triangles using a seed string. See 'Group triangles using seed string' for further information.

The **hatching switch** may be toggled between 'stored', 'temp' and 'retain'. Stored hatching will be stored on the .DPF when the grouping is accepted. Temporary hatching will be deleted when the grouping is accepted or rejected. Retain hatching will be kept on screen until you exit the major option.

Selecting **show ungrouped triangles** will highlight all the triangles which do not currently belong to any group.

When proceed is selected for the first time the triangles are grouped and hatched. A menu will then be displayed which prompts you to accept or reject the group.

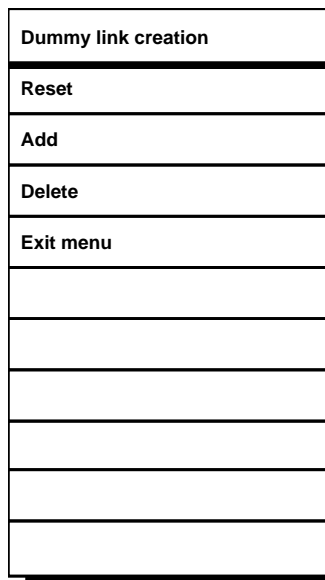
### Dummy links

When triangles are grouped the procedure you use is to select an initial triangle in the group and assign a group code, all adjacent triangles will then be given that group code unless a triangle side is formed from a string link or a null triangle is encountered. In these cases the next adjacent triangle is not considered. This process is called seeding. A triangle group can be added to by subsequent seeding operations. Also, a single group of triangles need not be contiguous.

In some situations the user may wish to restrict the seeding by introducing a dummy link. This changes the property of a triangle side that would not normally terminate seeding to be a string link which will restrict seeding.

If you select **Dummy link creation** you will be presented with this menu:

IGVISUTT.DAT, VIS027



Dummy link creation offers you the following options -

**Reset** - deletes all dummy links created.

**Add** - creates dummy links. You must pick the side of a triangle where you require a dummy link. The link will be highlit, proceed to accept the link, quit to reject the link or use Link amend.

**Link amend** - when you select this box you may toggle between the sides of the triangle highlighting each side in turn. Proceed allows you to select another dummy link. A second proceed terminates the dummy link creations.

**Delete** - deletes a dummy link. You are requested to pick the link to be deleted, once picked the link will no longer be highlit. Proceed will terminate Delete.

◇ *When you return to the Grouping of triangles menu, you will need to reselect the 'first triangle' to re-establish its hatching.*

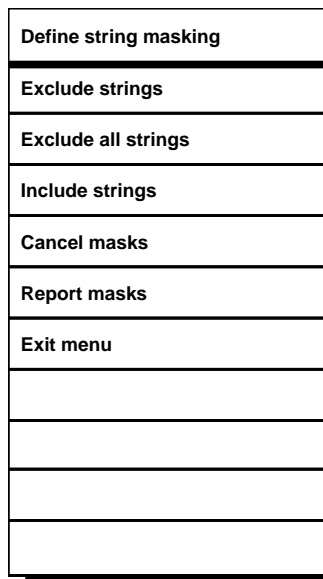


- ◇ *When you return to the Grouping of triangles menu, the Dummy link creation field will state 'yes' if you have created any links.*
- ◇ *When you exit from grouping options all dummy links will be deleted if you have created any stored hatching.*

### String masking

If you select **string masking** you will be presented with this menu -  
You can select strings to be masked or unmasked from the seeding operation.

IGVISUT.DAT, VIS024



**Exclude strings** - you must select a string to be masked.

**Exclude all strings** - you will exclude all strings.

**Include strings** - you must select a string to be unmasked.

**Cancel masks** - deletes all masks.

**Report masks** - displays a list of currently defined masks.

- ◇ *Exit from the grouping options cancels all mask selections.*

## Group triangles using seed string

Selects points on a string as seed points for grouping triangles. In this way, seed points may be pre-defined in the model data.

### Input

#### Graphics

IGVISUT.DAT, VIS016, VIS047

Group triangles by seeding	Group by seed string
Triangulation string label	Seed string label
Group code	Start chainage/ X coord
Dummy link creation No	Start point no./ X coord
Define string masking No	End chainage/ Y coord
Link tolerance 0.01	End point no./ Y coord
First triangle	
Boundary string label	
Seed string label	
Hatching switch (T)	
Show ungrouped triangles	

**Seed string label** defines the string containing the points to be used as seed points. A partial label may be specified.

Specify start and end SPRD to restrict the number of points on the string to be used as seed points.

## Group individual triangles

IGVISUT.DAT, VIS044, VIS045

Group triangles	Group individual triangles
Group triangles by seeding	Triangulation string label
Group individual triangles	Group code
Reset group codes	Hatching switch (T)
	Include triangle
	Exclude triangle

**Triangulation string label** is the label of the triangulation containing the triangles you wish to group.

**Group code** determines the group to which you wish to add triangles. If the group already exists, select a triangle which belongs to the group and the group code will be displayed in the scrolling menu. If the group is a new group, type the group code from the keyboard.

The **hatching switch** may be toggled between 'stored', 'temp' and 'retain'. Stored hatching will be stored on the .DPF when the grouping is accepted. Temporary hatching will be deleted when the grouping is accepted or rejected. Retain hatching will be kept on screen until you exit the major option.

**Include triangle** allows you to add a triangle to the selected group. When you select a triangle, the triangle is hatched and the triangle's number is displayed in the scrolling menu area. The hatched triangle is added to the group when you finish selecting triangles and select Proceed.

◇ *Triangles may be selected in succession without returning to the scrolling menu area. Select Quit when you wish to return to the menu area.*

**Exclude triangle** cancels the addition of a selected triangle so that it will not be added to the group when Proceed is selected.

When you have finished selecting triangles, select Proceed to add the triangles to the specified group. Select Quit to cancel the selected triangles so that they are not added to the group.

## Make assignments

This option allows you to add object and material information to an existing model and store this information in the EPIC Data Store.

IGVISUT.DAT, VIS048, VIS005

VISUALISE options	Make assignments
Change models	Assign flightpath string
Group triangles	Assign one point objects
Make assignments	Assign two point objects
Review assignments	Assign swept objects
Define eye and target	Assign dashed objects
Clear visualisation	Assign compound objects
EPIC Data Store report	Assign material to group
Submit EPIC data	
Exit VISUALISE	

**Assign flightpath string** defines a series of points (or ‘flightpath’) in EPIC from which frames can be produced by an imaginary camera. This is particularly useful for producing animated scenes.

**Assign one point objects** assigns objects to strings by repeating the object at each point along a string. One point objects may be used to produce features such as a row of trees running along a verge.

A single feature which may be placed with any orientation, such as a flagpole, can be defined by assigning a one point object to a string containing only one point.

**Assign two point objects** assigns objects to strings by repeating the object at every second point along the string. The intermediate points are used to define the orientation of the object. Two point objects may be used to produce features such as a line of lampposts running along a pavement.

A single feature which requires a particular orientation, such as a road sign, can be defined by assigning a point object to a string containing only two points.

**Assign swept objects** assigns a swept object to a string. The swept object is formed by sweeping a profile along the string to produce a feature, such as a hedgerow or fence.

**Assign dashed objects** assigns a dashed object to a string. The dashed object is formed by sweeping a profile a certain number of points along a string, and then leaving a gap before starting the sweep again. This

operation is repeated at regular intervals and can be used to produce features such as a broken white centreline on a road.

**Assign compound objects** assigns a compound object to a string. A compound object is a set of point, swept or dashed objects grouped together as a single entity.

**Assign materials** assigns a material such as concrete, brick or grass to pre-defined groups of triangles. By applying different materials to triangle groups a wide variation in surface colour and texture may be produced.

- ◇ *Strings to which objects are assigned must have an alpha character as the first character of their label, ie, the label A123 is acceptable whereas 1234 is not.*

## Assign flightpath string

IGVISUT.DAT, VIS005, VIS006

Make assignments:	Assign flightpath string
Assign flightpath string	String label
Assign one point object:	
Assign two point object:	
Assign swept object:	
Assign dashed object:	
Assign compound object:	
Assign material to group	

**String label** is the name of the string to be designated as a flightpath.

## Assign one point objects

IGVISUT.DAT, VIS005, VIS002

Make assignments	Assign one-point objects
Assign flightpath string	String label
Assign one point objects	Default objects
Assign two point objects	Object 1
Assign swept objects	Object 2
Assign dashed objects	Object 3
Assign compound objects	Object 4
Assign material to group	Object 5
	Object 6
	Object 7
	Object 8

**String label** is the name of the string to which an object is to be assigned. If a partial label is specified, all strings satisfying the partial label will have objects assigned to them.

Select **Default objects** to compare the default string labels of all one point objects in the visualisation table with the specified string(s). If a default string label matches the string label you specified, the object is displayed in the menu. Up to eight objects may be assigned to the string(s) on Proceed.

Alternatively, select **Object 1** to obtain the complete list of one point objects held in the visualisation table. Select the objects to be assigned from the list and Proceed.

## Assign two point objects

IGVISUT.DAT, VIS005, VIS003

Make assignments	Assign two-point objects
Assign flightpath string	String label
Assign one point objects	Default objects
Assign two point objects	Object 1
Assign swept objects	Object 2
Assign dashed objects	Object 3
Assign compound objects	Object 4
Assign material to group	Object 5
	Object 6
	Object 7
	Object 8

**String label** is the name of the string to which a two point object is to be assigned. If a partial label is specified, all strings satisfying the partial label will have objects assigned to them.

Select **Default objects** to compare the default string labels of all two point objects in the visualisation table with the specified string(s). If a default string label matches the string label you specified, the object is displayed in the menu. Up to eight objects may be assigned to the string(s) on Proceed.

Alternatively, select **Object 1** to obtain the complete list of two point objects held in the visualisation table. Select the objects to be assigned from the list and Proceed.

## Assign swept objects

IGVISUT.DAT, VIS005, VIS004

Make assignments	Assign swept objects
Assign flightpath string	String label
Assign one point objects	Default objects
Assign two point objects	Object 1
Assign swept objects	Object 2
Assign dashed objects	Object 3
Assign compound objects	Object 4
Assign material to group	Object 5
	Object 6
	Object 7
	Object 8

**String label** is the name of the string to which a swept object is to be assigned. If a partial label is specified, all strings satisfying the partial label will have objects assigned to them.

Select **Default objects** to compare the default string labels of all swept objects in the visualisation table with the specified string(s). If a default string label matches the string label you specified, the object is displayed in the menu. Up to eight objects may be assigned to the string(s) on Proceed.

Alternatively, select **Object 1** to obtain the complete list of swept objects held in the visualisation table. Select the objects to be assigned from the list and Proceed.



## Assign dashed objects

IGVISUT.DAT, VIS005, VIS007

Make assignments	Assign dashed objects
Assign flightpath string	String label
Assign one point objects	Default objects
Assign two point objects	Object 1
Assign swept objects	Object 2
Assign dashed objects	Object 3
Assign compound objects	Object 4
Assign material to group	Object 5
	Object 6
	Object 7
	Object 8

**String label** is the name of the string to which a dashed object is to be assigned. If a partial label is specified, all strings satisfying the partial label will have objects assigned to them.

Select **Default objects** to compare the default string labels of all dashed objects in the visualisation table with the specified string(s). If a default string label matches the string label you specified, the object is displayed in the menu. Up to eight objects may be assigned to the string(s) on Proceed.

Alternatively, select **Object 1** to obtain the complete list of dashed objects held in the visualisation table. Select the objects to be assigned from the list and Proceed.

## Assign compound objects

IGVISUT.DAT, VIS005, VIS042

Make assignments	Assign compound objects
Assign flightpath string	String label
Assign one point objects	Default object
Assign two point objects	Object
Assign swept objects	
Assign dashed objects	
Assign compound objects	
Assign material to group	

**String label** is the name of the string to which a compound object is to be assigned. If a partial label is specified, all strings satisfying the partial label will have an object assigned to them.

Select **Default object** to compare the default string labels of all compound objects in the visualisation table with the specified string(s). If a default string label matches the string label you specified, the object is displayed in the menu. Only the first compound object in the visualisation table is assigned to the string(s) on Proceed.

Alternatively, select **Object** to obtain the complete list of compound objects held in the visualisation table. Select the object to be assigned from the list and proceed.

## Assign material to group

IGVISUT.DAT, VIS005, VIS011

Make assignments	Assign materials
Assign flightpath string	Triangulation string label
Assign one point objects	Triangle group code
Assign two point objects	Default material
Assign swept objects	Material
Assign dashed objects	
Assign compound objects	
Assign material to group	

**Triangulation string label** identifies the triangulation to be used for the assignment.

**Triangle group code** indicates the triangle group to which a material is to be assigned.

Select **Default materials** to compare the default group codes of all materials in the visualisation table with the specified group code. If a default group code matches the group code you specified, the material is displayed in the menu. Only one material is assigned to the triangle group on Proceed.

Alternatively, select **Material** to obtain the complete list of materials held in the visualisation table. Select the material to be assigned from the list and Proceed.

## Review assignments

This option allows you to review the assignments which have already been made and disable or delete those which are no longer required. Enabling or disabling assignments indicates to EPIC which assignments are to be transferred to the visualisation file and which are to be ignored. Deleting assignments means that assignments are permanently removed from the EPIC Data Store.

- ◇ *Assignments which are disabled but not deleted may be re-enabled by using this option.*

IGVISUT.DAT, VIS048, VIS017

<b>VISUALISE options</b>	<b>Review assignments</b>
<b>Change models</b>	<b>Flightpath strings</b>
<b>Group triangles</b>	<b>Strings</b>
<b>Make assignments</b>	<b>Objects</b>
<b>Review assignments</b>	<b>Triangle groups</b>
<b>Define eye and target</b>	<b>Materials</b>
<b>Clear visualisation</b>	<b>Set all output to yes</b>
<b>EPIC Data Store report</b>	<b>Set all output to no</b>
<b>Submit EPIC data</b>	
<b>Exit VISUALISE</b>	

**Flightpath strings** allow flightpath string assignments to be reviewed.

**Strings** allow object assignments to be reviewed by string label.

**Objects** allow object assignments to be reviewed by object name.

**Triangle groups** allow material assignments to be reviewed by triangle group code.

**Materials** allow material assignments to be reviewed by material name.

**Set all output to yes** allows all assignment to be toggled to yes. This ensures that all assignments are output to a subsequently created .VIS file. Individual assignments may be reviewed and the output toggle set to 'No' if required.

**Set all output to no** allows all assignment to be toggled to no. This ensures that no assignments are output to a subsequently created .VIS file. Individual assignments may be reviewed and the output toggle set to 'Yes' if required.

## Review flightpath string

IGVISUT.DAT, VIS017, VIS018

Review assignments	Review flightpaths
Flightpath strings	<String label 1> Output (T)
Strings	<String label 2> Output (T)
Objects	<String label 3> Output (T)
Triangle groups	.
Materials	.
Set all output to yes	.*
Set all output to no	

**String label n** is the label of a flightpath string to which objects have been assigned. The complete list of flightpath strings is shown.

**Output** is a toggle switch which disables the associated flightpath string assignment when set to NO, and enables it when set to YES. If the toggle is set to DELETE, the assignment is deleted from the EDS.

## Review strings

IGVISUT.DAT, VIS017, VIS009, VIS020

Review assignments	Review strings	Review strings
Flightpath strings	String	Object Type
Strings	String	Output (T) Object
Objects	String	Type Output (T)
Triangle groups	String	Object Type
Materials	String	Output (T) Object
Set all output to yes	String	
Set all output to no	String	
	String	
	String	
	String	
	String	

**String label n** is the label of a string to which objects have been assigned. The complete list of strings with assigned objects is shown. Select a string label from the list to review the assignments for that string.

**Object name** is the name of an object assigned to the selected string. All objects assigned to the string are shown.

**Object type** is the type of the object, for example, point, swept, dashed etc.

**Output** is a toggle switch which disables the associated object assignment when set to NO, and enables it when set to YES. If the toggle is set to DELETE, the assignment is deleted from the EDS.

## Review objects

IGVISUT.DAT, VIS017, VIS012, VIS019

Review assignments	Review objects	Review objects
Flightpath strings	Object	<String label 1> Output (T)
Strings	Object	<String label 2> Output (T)
Objects	Object	<String label 3> Output (T)
Triangle groups	Object	<String label 4> Output (T)
Materials	Object	<String label 5> Output (T)
Set all output to yes	Object	.
Set all output to no	Object	.
	Object	*
	Object	
	Object	
	Object	

**Object name n** is the name of an object which has been assigned to a string. The complete list of assigned objects is shown. Select an object from the list to review all the strings to which that object has been assigned.

**String label n** is the label of a string to which the selected object has been assigned.

**Output** is a toggle switch which disables the object assignment for the associated string when set to NO, and enables it when set to YES. If the toggle is set to DELETE, the assignment is deleted from the EDS.

## Review triangle groups

IGVISUT.DAT, VIS017, VIS029, VIS022

Review assignments	Review triangle groups	Review triangle groups
Flightpath strings	Tria group	<Material 1>
Strings	Tria group	Output (T)
Objects	Tria group	<Material 2>
Triangle groups	Tria group	Output (T)
Materials	Tria group	<Material 3>
Set all output to yes	Tria group	Output (T)
Set all output to no	Tria group	.
	Tria group	.
	Tria group	.*
	Tria group	

**Triangle group n** is the code of a triangle group to which materials have been assigned. The complete list of triangle groups with assigned materials is shown. Select a group code from the list to review the assignments for that triangle group.

**Material** is the name of a material assigned to the selected triangle group. All materials assigned to the triangle group are shown.

**Output** is a toggle switch which disables the associated material assignment when set to NO, and enables it when set to YES. If the toggle is set to DELETE, the assignment is deleted from the EDS.

## Review materials

IGVISUT.DAT, VIS017, VIS030, VIS021

Review assignments	Review materials	Review materials
Flightpath strings	Material	<Triangle group 1> Output (T)
Strings	Material	<Triangle group 2> Output (T)
Objects	Material	<Triangle group 3> Output (T)
Triangle groups	Material	.
Materials	Material	.*
Set all output to yes	Material	
Set all output to no	Material	
	Material	
	Material	
	Material	
	Material	

**Material n** is the name of a material which has been assigned to a triangle group. The complete list of assigned materials is shown. Select a material from the list to review all the triangle groups to which that material has been assigned.

**Triangle group n** is the code of a triangle group to which the selected material has been assigned.

**Output** is a toggle switch which disables the material assignment for the associated triangle group when set to NO, and enables it when set to YES. If the toggle is set to DELETE, the assignment is deleted from the EDS.



## Define eye and target

IGVISUT.DAT, VIS048, VIS014

VISUALISE options	Define eye and target
Change models	Eye X Y Z
Group triangles	
Make assignments	Target X Y Z
Review assignments	
Define eye and target	
Clear visualisation	
EPIC Data Store report	
Submit EPIC data	
Exit VISUALISE	

**Eye coordinates X,Y,Z** define the position of the viewer.

The Z coordinate may be specified in various ways dependent upon the PSM in use. For example, if TRIGXY is used, the level is calculated from the triangulation model. If XY is used, only the X and Y coordinates are returned from the screen and so the Z coordinate must be typed in.

The level returned by TRIGXY is a ground level and will normally need to be raised using Level Amend so that a satisfactory view is obtained.

**Target coordinates X,Y,Z** define the position of the point to be viewed (the target).

## Clear visualisation

This option deletes all the assignments in the EPIC Data Store. It also clears the eye and target coordinates, frame number, anti-aliasing setting and shading type. You should only use this option if you are sure that this data is no longer required.

IGVISUT.DAT, VIS048

VISUALISE options:
Change models
Group triangles
Make assignments
Review assignment:
Define eye and target
Clear visualisator
EPIC Data Store repor
Submit EPIC data:
Exit VISUALISE

## EPIC Data Store report

This option produces a report containing all the details of the visualisation including the assignments which have been made.

IGVISUT.DAT, VIS048

VISUALISE options:
Change models
Group triangles
Make assignments
Review assignment:
Define eye and target
Clear visualisator
EPIC Data Store repor
Submit EPIC data:
Exit VISUALISE

## Submit EPIC data

This option allows you to submit data held in the EPIC Data Store for processing by EPIC.

IGVISUT.DAT, VIS048, VIS023

VISUALISE options	Submit EPIC data
Change models	Make data file
Group triangles	Invoke MSEPIC
Make assignments	
Review assignments	
Define eye and target	
Clear visualisation	
EPIC Data Store report	
Submit EPIC data	
Exit VISUALISE	

**Make data file** converts the data held in the EPIC Data Store to a visualisation file (‘.vis’) which is suitable for processing by EPIC.

**Invoke MSEPIC** suspends MOSS and runs EPIC.

- ◇ *If you wish to invoke EPIC from MOSS, ensure that your machine has enough memory to run both programs simultaneously.*

# Chapter 12 Major option DRAINAGE

## Major option DRAINAGE

### Introduction

Major option DRAINAGE is used to design drainage networks by the two-way exchange of data between itself and an external program. These programs are Micro Drainage developed by Micro Drainage Limited, Wallrus and MicroRAT developed by Hydraulics Research Limited. Such a program is WALLRUS, the Wallingford Storm Sewer Package developed by Hydraulics Research Ltd. Data is transferred between MOSS and WALLRUS via an intermediate Sewer System Data (SSD) file.

DRAINAGE may also be used to design drainage networks in conjunction with other external programs. Data is transferred between MOSS and the external program via a generic intermediate file called a MOSS Drainage File, or MDF. The MDF has other uses, being the DRAINAGE equivalent of GENIO.

You may customise your installation to make either Micro Drainage, MicroRAT or Wallrus the chosen external program. This customisation is carried out in the parameter file 'prmdef.dat', it may therefore be changed at any time, or set differently for individual users. Once set, menu selections are limited to match the requirements of the defined external program.

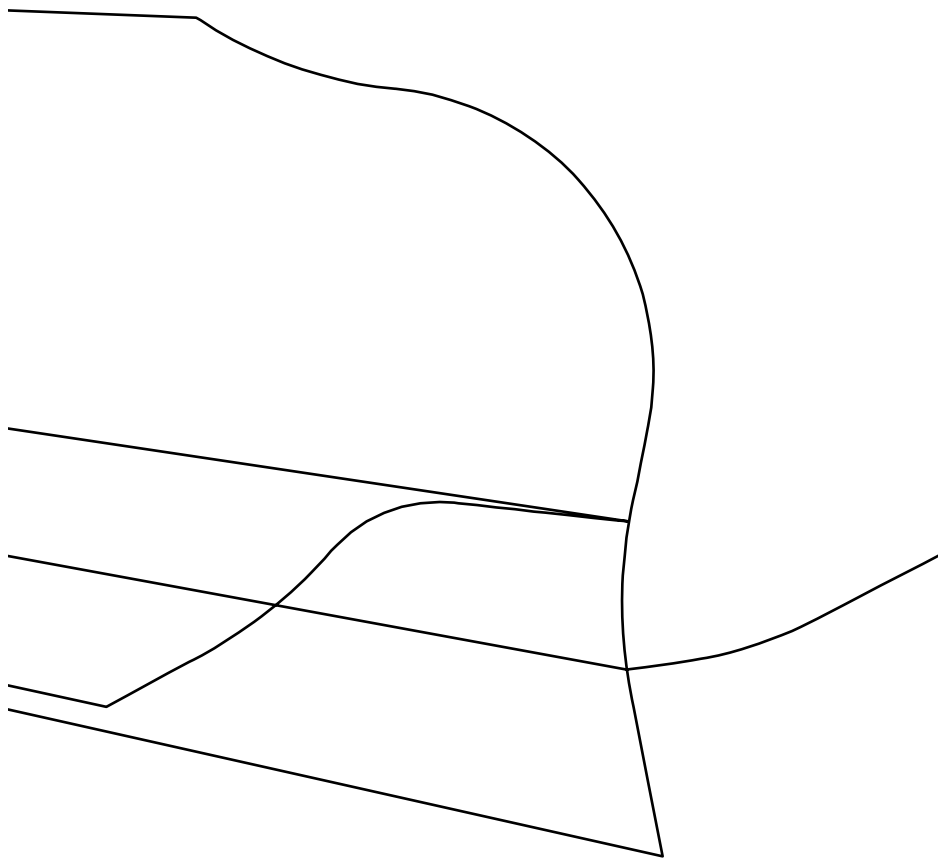
A plan layout of a drainage network can be designed interactively in MOSS and the details copied to the transferintermediate file. Once the data has been analysed by the external program, results can be fed back to MOSS allowing the continuation of the design process.

Separate, partially separate and combined sewer systems can all be designed using DRAINAGE. A separate system is designed by using two drainage models, one for foul and one for surface water. The two models are drawn overlaid on the same ground and triangulation models.

DRAINAGE allows you to:

- define construction details for a network.
- set up drawing default values.
- set up pipe length measurement default.
- create and position manholes, pipes, and gullies forming drainage networks.
- measure pipe lengths from manhole edge to manhole edge or from manhole centre to manhole centre.
- create curved pipe runs offset from carriageway strings.

- perform catchment area calculations with the aid of boundary, triangulation and surface models.
- set up system control parameters.
- output data from MOSS to an external program and feed the data back again.
- invoke an external program from within MOSS.
- produce reports on the hydraulic and construction details of the network.



**Figure 12 - 1 A typical drainage network**

## Outline of design process

The following is a general method for designing a drainage network using DRAINAGE:

### Model preparation

Triangulation and/or boundary models are prepared for the ground which the network is to cover. In addition, a surface model can be created to include ridge strings, valley strings and flow lines. These models are then drawn on the screen.

◇ *These models assist in the design of the network but are not essential for using the DRAINAGE software. Triangulation models should be created using major option TRIANGLE. Surface models should be created using major option SURFACE.*

The ground model which the network is to cover is also drawn on the screen.

The name of the drainage model to be used for the network design is specified. The drainage model is a unique type of model within MOSS. The suffix DRAI is attached to a drainage model automatically to distinguish it from other model types. A new model is automatically created if a model of the specified name does not exist already.

### Design preparation

Before the network design begins, manhole, pipe and gully construction defaults can be set up which will apply throughout the design unless altered using the 'Add/Amend' facilities. In addition, a pipe channel index should be chosen to indicate which pipe shape set is valid for the network design.

Pipe length measurement can be set to be either manhole edge to manhole edge or manhole centre to manhole centre. Throughout DRAINAGE and DRAW pipe length annotation will automatically reflect this setting. The setting may be established for each drainage model, and a default defined in the parameter file 'prmdef.dat' using the parameter DRAIMEAS.

### Adding manholes

Within MOSS, the drainage network must be designed by adding manholes first, followed by pipes and gullies. This is because a pipe is formed by the linking of two manholes and a gully must connect to a pipe or manhole. However, this sequence is not restrictive as additional manholes, pipes and gullies may be included at any stage during the design.

The easiest method of positioning manholes on the screen is by using the TRIGXY point selection method, which gives each manhole a cover level taken from the triangulation of the ground model.

It is not necessary for the manhole positions to be exact at this stage as they may be amended later when a clearer picture of the required network plan layout has emerged.

Invert levels can be added at this stage (if, for example, an existing network is being modelled) or they can be left null for subsequent calculation by the external program. Note that invert levels must be given to all manholes or not given at all.

### **Drainage proximity check**

Drainage proximity checking searches for a clash between manholes and strings satisfying a string selection mask. If the distance between the manhole and the string is less than a specified value the clash position is displayed on screen with a warning, and an alternative position is offered. Either the new or the original position may be accepted. Alternatively the manhole position may be respecified.

### **Adding branches**

The next stage is to link the manholes together, one branch at a time, to form the drainage network. This is achieved by linking together the manholes comprising the first branch and storing the branch. This is repeated for all the other branches until a dendritic network is created. The pipes within each branch are automatically numbered in sequence when the branch is stored.

During the linking process, the proximity and length of the pipes are checked. The pipe check distance and the maximum pipe length are set as defaults in the parameter file, but may be accessed and changed from within IG mode. If a pipe is found to exceed the specified maximum length, or the distance between a pipe and a string is less than a specified value, a warning is displayed which may be overridden. In the case of a length check being corrected, a new position is offered, together with the option to accept the original position or to redefine the branch.

### **Calculating sub-catchment areas**

Using the 'Area calculations' facilities, total and, impervious and roof areas may be assigned to each pipe length in the network. The areas can be estimated or calculated using the triangulation and surface models.

### **MOSS and the external program**

Once all manholes, branches and gullies are in place, the data describing the network is written to a n intermediate file for design and/or analysis by an external program. If MicroDrainage is being used, the data should be written to a Micro Drainage .sws or .fws file. If WALLRUS is being used, the data should be written to a Sewer System Data (.SSD) file. For other external programs, the data may should be written to a MOSS Drainage file (MDF).

On completion of the design and analysis by the external program, drainage data including pipe sizes and levels is transferred back to major option DRAINAGE.

The designed network can now be amended and processed again by the external program if required until the design is satisfactory. Once the design is complete, drainage reports can be written and final construction drawings

produced in both plan and section. UPM command files may be used to produce drainage construction schedules.

## Micro Drainage

The Micro Drainage link provides a bi-directional data transfer to and from DRAINAGE to MicroDrainage Version 5.0. The link permits analysis of the drainage network designed in MOSS using the Micro Drainage suite of programs.

The Micro Drainage program suite incorporates:

- Rational method
- Foul method
- Schedule program
- Simulation

For a description of the full functionality available within each of the above please consult the Micro Drainage documentation.

The following table gives an indication of data portability both to and from Micro Drainage.

Description	To / From	Units	Range	Variable No.	Notes
Job title	<---> Note 3				1. Derived from the full DRAINAGE model name. 2. Job title may be changed when the data is saved in Micro Drainage.
Global values				23 = 3	Other Global values vary for the storm and foul programs in Micro Drainage.
Roughness values	<---> Note 3	Ks	0.001 999.0	0	
Pipe number	<---> Note 3		1.000 999.999	1	
Pipe length	<---> Note 3	m	1.00 999.99	2	
Total area	<---> Note 3	Ha	0.000 999.999	4	
Cover levels	<---> Note 3	m	-50.000 999.999	21 25	= upstream = downstream
Invert levels	<--->	m	-50.000 999.999	17 24	= upstream = downstream 1. If variable 17 is set then 18 must also be set to 1. 2. This data may be overwritten if Rational



					or Foul programs are used.
Percentage paved area	<---> Note 3	Fraction	0.051 1	45	MOSS stores both the total and paved areas as actual values. The fraction is calculated from the values.
Pipe diameter	<--->	Integer	>65mm max 9999	5	1.If pipe diameters are output from MOSS, flag at variable 14 must also be set to pipe diameter. 2.Pipes < 65mm are treated as a special pipe section.
Pipe shapes	<---> Note 3	Integer	1 to 65 Note 1.	5	Pipe shape data is used by MOSS for annotation and reporting purposes.
Manhole dimensions	<---> Note 2.	mm	1 to 9999	30 32	= diameter/length = width 1. The flag at variable 46 must be set to 1 if the upstream manhole size is specified.
Ground levels	<---> Note 3	m	-50.000 999.999	38 39	= 1/3 level = 2/3 level

- ◇ *Note 1. Micro Drainage has a range of up to 65 different pipe shapes and hydraulic conduits. These consist of rectangular, egg shaped, open and dual and triple pipes. All pipe shapes are referenced with a number from 1 to 65. Micro Drainage does not accept pipe diameters less than 65mm. Where a number larger than 65 is given the pipe is assumed to be circular. Full details of each conduit are stored in the files 'alternat.sec' (user defined) and 'conduit.sec' (standard file supplied with the system) which are located in the Micro Drainage data directory. MOSS will only reference 'conduit.sec'.*
- ◇ *Note 2. The Micro Drainage Schedule program will size manholes in accordance with the information contained in the manhole size file. The size of the manhole is determined by the largest pipe entering it and the depth from cover level to invert level. The file that comes with the software is based upon the 'Sewers for Adoption' standards, although you may provide your own file. The Schedule program will overwrite any manhole sizes output by MOSS, for this reason the transfer is only possible from Micro Drainage to MOSS and is optional.*
- ◇ *Note 3. Although these items are transferred in both directions it must be noted that amending them in Micro Drainage will cause problems when returning to MOSS.*

**The Micro Drainage file**

A single Micro Drainage file may contain up to 600 pipelines.

The file is made up of 14 strings (job titles, etc) and 26 global variables followed by up to 600 pipelines each with 51 variables (numbered from 0 to 50). For full details of the Micro Drainage sequential file structure see the Micro Drainage documentation.

### Invoke Micro Drainage

When you select 'Invoke Micro Drainage' from within MOSS, the system will check that Micro Drainage is available on your machine, and that it is not already running.

When Micro Drainage is started MOSS will continue to operate, allowing flexibility in the order in which data can be transferred. When you exit MOSS, Micro Drainage will not be terminated.

## WALLRUS

WALLRUS incorporates the following design methods:

- **Modified Rational Method (MicroRAT)** designs pipe or channel sizes and gradients for a drainage network. It is the simplest and quickest method to use when designing a new system.
  - ◇ *MicroRAT is sold as a separate product which interfaces to DRAINAGE in its own right. The term 'WALLRUS' is used throughout this chapter but applies to MicroRAT also.*
- **Hydrograph Design Method** designs pipe or channel sizes in a network with defined levels for a specified return period of flow. This method generally produces a more economical design than the Rational method for larger catchment areas.
- **Simulation Method** simulates flow in an existing or a designed system with surface flooding or surcharge during rainfall events. This method allows a system designed for pipe full flow at a moderate return period to be simulated for storms of more extreme return periods.

The following table gives an indication of the data required by WALLRUS before a particular design method can be used. For further details, refer to the WALLRUS documentation.

Minimum data from MOSS	Possible WALLRUS use
Manhole cover levels Manhole positions Sub-catchment areas	Pipe sizes and invert levels using MicroRAT
Manhole cover levels Manhole positions Pipe levels Sub-catchment areas	Pipe sizes using Hydrograph Method
Manhole cover levels	Analysis using Simulation Method Discharge hydrograph using Hydrograph Method

Manhole positions	
Pipe levels	
Pipe sizes	
Sub-catchment areas	

## Assumptions and limitations

- Pipe lengths are measured from manhole edge to manhole edge and for curved pipe lengths are calculated by summings the sum of the links forming the curve. is used.
- Ancillary records created in WALLRUS are ignored by DRAINAGE.
- All levels stored and displayed in MOSS are invert levels.
- Levels must be specified for all manholes and pipes or no manholes and pipes.
- Networks are restricted to 2000 pipes, 2000 manholes and 999 branches.
- Only one network is allowed per drainage model.
- Networks created wholly by WALLRUS or MicroRAT cannot be used by DRAINAGE because they do not contain positional data.
- All manholes are assumed to be benched for design purposes.
- Gullies should only be added when a network containing manholes and branches has been analysed by WALLRUS. This is because gullies are not tied in to the main network so if a change is made to the network, the gullies may no longer be in the correct position.
- In WALLRUS, any information which directly affects the layout of the drainage model should not be changed if it is to be fed back into MOSS. This includes areas, pipe lengths and cover levels.
- Standard or non-standard pipe shapes must be used throughout the network. The set of pipe shapes used is dictated by the pipe channel index.
- If an offset manhole is moved after it has been created, then its offset characteristics are removed and it becomes an individual manhole.
- Individual manholes can only be linked by straight pipes.

## String storage in DRAINAGE

The following tables show the data stored in each dimension of a drainage string. This information can be used when annotating a drainage drawing by using the dimension number with DRAW options 858 and 859. See major option DRAW for further details.

Text data is stored across two dimensions.

### Manhole storage

There is only one manhole string in a drainage network and this string has the label PMAN.

Dim	Contents	Dim	Contents
1	Manhole X	16	Toggle indicator
2	Manhole Y	17	Branch cross reference
3	Cover Z	18	Main branch number
4	Manhole label	19	Incoming branch 2
5	Manhole number	20	Incoming branch 3
6	Length	21	Incoming branch 4
7	Width	22	Incoming branch 5
8	Shape	23	Incoming branch 6
9	Cover type	24	Incoming branch 7
10	Construction type	25	Incoming branch 8
11	Bench/sump	26	Incoming branch 9
12	Manhole X	27	Incoming branch 10
13	Manhole Y	28	Reference string (offset manholes)
14	Invert Z	29	Curve pipe indicator (offset manholes)
15	Sump depth	30	Offset (offset manholes)

### Branch storage

Each branch in a network is stored as a string with a label of the form Sbbb, where bbb is the branch number.

Dim	Contents	Dim	Contents
1	Upstream X	16	Downstream X
2	Upstream Y	17	Downstream Y
3	Upstream Z	18	Downstream Z
4	Manhole label	19	Manhole label
5	Manhole number	20	Manhole number
6	Branch number	21	Invert type
7	Shape	22	Pipe type
8	Roughness factor	23	Joint type
9	Major dimension	24	Bed type
10	Minor dimension	25	Surround type
11	Toggle indicator		
12	Manhole cross reference		
13	Roof area		
14	Impervious area		
15	Total area		

## Gully storage

There is only one gully string in a drainage network and this string has the label PGUL.

Dim	Contents	Dim	Contents
1	Gully X	10	Junction Y
2	Gully Y	11	Junction Z
3	Gully cover Z	12	Pipe size
4	Outlet invert Z	13	Toggle indicator
5	Gully label	14	DS invert type
6	Gully number	15	Pipe type
7	Diameter	16	Joint type
8	Surface adjustment	17	Bed type
9	Junction X	18	Surround

## Macrosymbols used in DRAINAGE

The following macrosymbols are used in drawing the network:

- DRAINSY1 Manhole symbol
- DRAINSY2 Gully symbol
- DRAINSY3 Open channel junction symbol
- DRAINSY4 Outfall symbol

◇ *The size of the drawn manhole symbol is proportional to the dimensions of the manhole chamber and does not just represent the manhole cover.*

## Drawing a network

Several options exist within major option DRAW for drawing drainage networks. These include:

- Minor option 828 Draw drainage network
- Minor option 829 Draw drainage section
- Minor option 858 Information along a string
- Minor option 859 Information at points

Minor options 858 and 859 are particularly useful for annotating pipes. For example, using minor option 858 with dimensions -21.0, -23.0 or -24.0 you may annotate pipes with their length and gradient and show the difference in level between manholes.

For further details, refer to Chapter 3, major option DRAW.

## Terms and definitions

**Branch.** A number of pipes in series, numbered consecutively in a downstream direction.

**Catchment.** An area served by a single drainage network.

**Dendritic network.** A tree-like network with all branches converging towards a common outfall.

**Impervious, impermeable.** Description of a surface type which resists the infiltration of water; in practice some infiltration does occur.

**Manhole.** A structure that exists at any change in direction or gradient of a pipe, or at a junction. The term manhole is used to refer to open junctions and outfalls as well as normal manholes.

**Pervious, permeable.** Description of a type of ground surface through which water may infiltrate; some surface runoff does occur.

**Pipe invert.** The lowest point on the internal bore of a pipe.

**Pipe soffit.** The highest point on the internal bore of a pipe.

**Sub-catchment.** The area draining to a single pipe length.

## Parameters and defaults

The following is a list of toggle values and their meanings which appear in the DRAINAGE menus. In each case, the first value listed is the default value.

### Manhole shape

Circ	circular
Rect	rectangular
Squr	square

### Cover type

Heavy	heavy duty
Light	light duty
Medium	medium duty

### Manhole construction type

Concrete	concrete
Brick	brick
Plastic	plastic
P.C. Conc	pre-cast concrete
Ins. Conc	in situ concrete

### Manhole type

Bench	benched manhole
Sump	sump manhole

### Gully pipe type

Concrete	concrete
Plastic	plastic
Clay	clay
Pfib	pitch fibre
E.S.Conc	extra strength concrete
S.R.Conc	sulphate resisting concrete

**Gully pipe joint type**

Rigid  
Flexible  
Pressure  
Adhesive

**Gully pipe bed type**

Concrete	concrete
Shingle	shingle
Sand	sand
Suitable	other suitable material
E.S.Conc	extra strength concrete
S.R.Conc	sulphate resisting concrete

**Gully pipe surround**

Concrete	concrete
Shingle	shingle
Sand	sand
Com Fil	common fill
E.S.Conc	extra strength concrete
S.R.Conc	sulphate resisting concrete

**Gully pipe connection type (DS invert type)**

Junction	connection to pipe
Normal	normal connection to manhole
Ramp	ramp connection to manhole
Backdrop	backdrop connection to manhole

**Pipe type**

Concrete	concrete
Plastic	plastic
Clay	clay
Pfib	pitch fibre
Cast Iron	cast iron
Brick	brick

**Pipe joint type**

Rigid  
Flexible  
Pressure  
Adhesive

**Pipe bed type**

Concrete	concrete
Shingle	shingle

Suitable other suitable material  
Sand sand

**Pipe surround**

Concrete concrete  
Sand sand  
Com Fil common fill  
Shingle shingle

**Pipe connection type (DS invert type)**

Normal normal connection to manhole  
Ramp ramp connection to manhole  
Backdrop backdrop connection to manhole

**Pipe channel shape (index 0 closed) - MicroRAT and Wallrus only.**

Circ	circular	0
Egg	broad egg	1
Rect	rectangle	2
Open	trapezoidal	3
Egg2	narrow egg	5
Oval	oval	6
Utop	u-shaped	7
Cnet	cunette	8
Arch	arch	9

**Pipe channel shape (index 1 open) - MicroRAT and Wallrus only.**

Circ	circular	0
Egg	broad egg	1
Rect	rectangle	2
Open	trapezoidal (not fixed)	3
Orec	open rectangle	4
OU	open u-shaped	5
OT21	open trapezoidal (fixed side slope 2:1)	6
OT14	open trapezoidal (fixed side slope 1:4)	7
OT12	open trapezoidal (fixed side slope 1:2)	8
OT11	open trapezoidal (fixed side slope 1:1)	9

◇ *For further details of pipe channel shapes, refer to the WALLRUS documentation.*

**MOSS Drainage File (MDF)**

The MDF is an external file which contains both hydraulic and construction data from the drainage model. This allows external programs to perform



calculations using the data and the entire drainage network can be reconstructed if required.

A comment file can be associated with an MDF. The comment file contains descriptions of all of the records in the MDF and is read when an MDF is created.

Each MDF contains data for a single network only.

### **MDF format**

The MDF is an ASCII fixed format file which is divided into sections:

Section 000	User defined comments
Sections 100 to 199	System control parameters
Sections 200 to 299	Manhole data
Sections 300 to 399	Branch data
Sections 400 to 499	Pipe data
Sections 500 to 599	Gully data
Sections 600 to 699	Reserved for future use
Sections 700 to 999	User defined data

Records within sections 100, 110, 120, 200, 300, 400 and 500 have standard definitions and are used by DRAINAGE when reading or writing an MDF. Other sections may be defined by the user for other purposes but will not be used by DRAINAGE.

Each record within a section has the following format:

#### **Columns 1 to 5**

Line number (right justified)

#### **Column 6**

A space character

#### **Columns 7 to 11**

Record type:

xxxxy where xxx is the section number  
yy is record index within the section.

#### **Column 12**

Data type:

C	Character data
I	Integer data
R	Real data
T	Toggle

#### **Column 13**

A space character

#### **Columns 14 to 45**

Drainage data.

Numerical data may be in integer or real notation and lie anywhere within the field.

Character data may contain embedded spaces.

#### **Column 46**

A space character

**Columns 47 to 80**

Record description. The description may be read from a comment file when the MDF is created, depending upon the MDF level used. The MDF level is set in the 'Data to MDF' menu.

◇ *Descriptions are not read by major option DRAINAGE.*

**Example**

```
1 10001C SIMPLE DESIGN DRAINAGE      DRAI Drainage model name
```

**Comment file format**

The comment file is an ASCII file with the following format:

**Columns 1 to 5**

Record number

The record number of the record in the MDF to which the description applies.

**Column 6**

A space character

**Columns 7 to 40**

Record description

**Example**

```
10001 Drainage model name
```

**Use of the MDF**

Data in an MDF serves the dual purpose of being computer readable and acting as a report for a scheme. The file is arranged so that the first two records in each section (eg, manhole name and number) uniquely identify the item to which all subsequent records with the same section number refer. This means that any duplicate record in the section overwrites the previous record.

For example, if as the file is read, manhole AAAA1 is read on record types 20001 and 20002 then all subsequent data on records 20003 to 20017 inclusive are assigned to manhole 1. When another manhole is read, ie, manhole AAAA2 from the next pair of 20001 and 20002 records, then all subsequent manhole data is assigned to that manhole until the next 20001 record is encountered.

All data in an MDF is read regardless of whether the data is already stored in the drainage model, so a network may be appended to or completely rebuilt.

Not all data in each section has to be present, provided sufficient information can be obtained from the MDF and existing drainage model for a network to be created. For example, a program which adds invert levels to manholes in an existing drainage model need only write an MDF containing 20001, 20002 and 20011 records.

◇ *Records from different sections may be interwoven in an MDF.*

### Standard record types

In the following tables:

C	Character data
I	Integer data
R	Real data
T	Toggle

### System control parameters

Record type	Data	Description
10001	C	Drainage model name for scheme
10002	C	Job title
11001	T	Coordinate units (m/ft)
11002	T	Pipe dimension units (m/mm/ft/in)
11003	T	Area units (ha/m**2/acres/ft**2)
11004	T	Flow units (m**3/s lt/s ft**3/s)
11005	T	Velocity units (m/s ft/s)
11006	T	Cover units (m/mm/ft)
11007	T	Dendritic/looped network
11008	T	Pipe measurement Edge/Centre
12001	I	Major time step
12002	T	UK/international
12003	T	Wallingford/SCS
12004	R	Global dry weather flow
12005	T	Design pipe sizes (y/n)
12006	T	Diameter not decrease (y/n)
12007	R	Soil index
12008	R	SCS constant
12009	I	Version of MOSS
12010	R	Minimum pipe diameter

### Manhole data

Record type	Data	Description
20001	C	Manhole label
20002	I	Manhole number
20003	T	Manhole shape
20004	T	Manhole cover type
20005	T	Manhole construction type
20006	T	Manhole type
20007	T	Manhole/outfall/open junction
20008	R	Manhole X coordinate
20009	R	Manhole Y coordinate

20010	R	Z cover
20011	R	Z invert
20012	R	Z soffit
20013	R	Manhole length
20014	R	Manhole width
20015	R	Manhole diameter
20016	R	Sump depth
20017	I	1=OK, 2=surcharged, 3=flooded

Branch data

Record type	Data	Description
30001	C	Current manhole label
30002	I	Current manhole number
30003	I	Current branch number
30004	I	Current branch point number
30005	C	Previous manhole label
30006	I	Previous manhole number
30007	C	Next manhole label
30008	I	Next manhole number

Pipe data

Record type	Data	Description
40001	I	Branch number
40002	R	Pipe number
40003	T	Pipe type (closed/open)
40004	T	Pipe shape
40005	R	Major dimension
40006	R	Minor dimension
40007	R	Upstream X coordinate
40008	R	Upstream Y coordinate
40009	R	Upstream Z invert
40010	R	Downstream X coordinate
40011	R	Downstream Y coordinate
40012	R	Downstream Z invert
40013	T	Roughness equivalent
40014	R	Roughness value
40015	T	Pipe construction type
40016	T	Pipe joint type
40017	T	Pipe bed type
40018	T	Pipe surround material type
40019	T	Downstream invert type
40020	R	Total area contributing
40021	R	Impervious area

40022	R	Roof area
40023	R	Depth of flow
40024	R	Flow rate
40025	R	Velocity of flow
40026	R	Dry weather flow

### Gully data

Record type	Data	Description
50001	C	Gully label
50002	I	Gully number
50003	R	X coordinate
50004	R	Y coordinate
50005	R	Z ground
50006	R	Surface adjustment height
50007	R	Z cover
50008	R	Outlet depth
50009	R	Z outlet invert
50010	R	X junction
50011	R	Y junction
50012	R	Z junction
50013	R	Gully pipe diameter
50014	T	Gully pipe construction type
50015	T	Gully pipe joint type
50016	T	Gully pipe bed type
50017	T	Gully pipe surround type
50018	T	Gully pipe invert type

## Access to major option DRAINAGE

<b>Design Options</b>
ALIGNMENT
H & V alignment design
SECTION
Extraction of sections
DESIGN
Feature strings
INTERFACE
Earthworks design
<b>DRAINAGE</b>
Design and analysis
EDIT
Strings and points
COPY
Copy/move model data
REPORT
Models/strings/points

## Model selection

IGSEWAT.DAT, SEW001

<b>Model for DRAINAGE</b>
Drainage model
Ref/boundary model (opt)
Triangulation model (opt)

**Drainage model** is the name of a model with model type DRAI in which drainage information is stored. For a new model, select Proceed to create the model when prompted to do so.

**Reference/boundary model** (optional) is the name of a model containing reference strings used to create offset manholes. If boundary strings are to be used for area calculations, they must also be in this model.

**Triangulation model** (optional) is the name of a model with model type TRIA to be used for area calculations and to assist in the specification of manhole cover levels (optional).

In addition to the above models, a surface model can be created from the specified triangulation model using major option SURFACE. This would typically include ridge strings, valley strings and flow lines to assist in the interpretation of sub-catchment areas and the placement of drainage gullies collecting surface runoff.

- ◇ *All required models should be drawn on the screen before entering DRAINAGE. Drawing the ground model over the triangulation model ensures that strings from the ground model are easily selectable.*
- ◇ *Only one network is allowed per drainage model.*

## Drainage design

IGSEWAT.DAT, SEW002

Drainage design
Add/amend manhole
Add/amend branch
Add/amend gully
Construction defaults
Area calculations
MOSS to Drainage analysis
Drainage analysis to MOSS
Drawing management
Report network
Copy drainage model

**Add/Amend manhole** adds new manholes to the network or amends existing ones.

**Add/Amend branch** links manholes or changes the links between manholes selected from the screen. The links between the manholes correspond to pipes which together form a branch.

**Add/Amend gully** creates a gully with specified characteristics or amends the characteristics of an existing gully.

**Construction defaults** sets up default values for manholes, pipes and gullies.

**Area calculations** is used to evaluate surface runoff into a part of a network.

**MOSS to Drainage analysis** Drainage analysis is used to pass drainage information to Micro Drainage, WALLRUS, or MicroRAT. The selection is pre-determined by the parameter file 'prmdef.dat'..

**Drainage analysis to MOSS** MOSS Drainage Format is used to input or output drainage information using MOSS Drainage Format file to MOSS.

**Drawing management** sets up values to be used in drawing the network.

**Report network** is used to report hydraulic and construction information on the network.

**Copy drainage model** copies a network from one drainage model to another.

- ◇ *The 'Drawing management' menu is the first menu to appear if you are amending an existing drainage model. This is so all drainage drawing defaults can be amended and ensures that the current DRAINAGE model is redrawn before continuing with the design.*

## Add individual manholes

'Add individual manholes' is used to add manholes to a network in plan view. Once the manholes have been positioned, the rest of the drainage network can be defined.

- ◇ *Individual manholes can only be linked by straight pipes.*

IGSEWAT.DAT, SEW003, SEW004

Add/amend manhole	Add individual manholes
Add individual manholes	Manhole label number
Add offset manholes	Manhole X Y
Amend manhole	Cover Z
Delete manhole	Invert Z
	Shape (T)
	Length
	Width
	Cover type (T)
	Construction type (T)
	Bench / Sump (T)
	Sump depth



Add individual manholes	
Manhole label	number
Manhole	X Y
Cover	Z
Invert	Z
Shape	(T)
Length	
Width	
Cover type	(T)
Construction type	(T)
Bench/sump	(T)
Sump depth	
M'Hole / Outfall / Open junction	(T)

**Manhole label and number** provide the manhole with a unique identifier. The label can be up to four characters long and the number up to four digits long. The number is incremented by one automatically after the addition of each manhole.

**Manhole X and Y** are the manhole coordinates.

**Cover Z** is the ground level at the centre of the manhole.

- ◇ *The point selection method TRIGXY automatically calculates the level at any point by interpolating values from the triangulation model. By using this PSM, the manhole x and y coordinates and the cover level are defined together.*

**Invert Z** is the invert level of the outgoing pipe of the manhole.

- ◇ *Manholes are assumed to be benched for design purposes, so that invert levels given for manholes are the same as those for the outgoing pipe.*
- ◇ *When designing a new network, the Invert Z value may be calculated by WALLRUS and may therefore be left blank.*

**Shape** describes the shape of the manhole chamber in plan view.

- ◇ *Pipes are drawn as if connected to circular manholes, no matter what the specified shape of the manhole.*

**Length and width** give the dimensions of the manhole chamber. For circular manholes only length is required which defines the diameter of the circle.

- ◇ *For open junctions and outfalls, the length and width are ignored.*

**Cover type** describes the manhole cover duty.

**Construction type** is the manhole construction material.

**Bench / Sump** describes the manhole invert type. For design purposes, all manholes are assumed to be benched.

**Sump depth** is the depth of the manhole sump if a sump manhole is to be added. It is measured from the outgoing pipe invert to the sump invert.

**Manhole/Outfall/Open Junction** defines the type of structure to be added. Different symbols are used on the network depending upon the structure type.

## Add offset manholes

'Add offset manholes' is used to add manholes offset from a reference string in plan view. Offset manholes are particularly useful for highway drainage where they may be placed with reference to a kerb or the back of verge and linked with curved pipes if required.

Offset manholes are drawn along a temporary offset string, which is automatically deleted once the offset manholes have been accepted. The manholes may then be linked together to form a branch. The direction of the branch is determined by the position of the upstream and downstream manholes and so need not be the same as the direction of the reference string. Individual manholes may also be included in the same branch, but they cannot be joined with the curved pipes.

The links (ie, pipes) between the offset manholes may follow the path of the reference or temporary offset string and be curved, or they may be straight as for individual manholes. The curvature of curved pipes is dependent upon the number of points in the reference string, ie, no curve fitting is used. The greater the number of points in the reference string, the smoother the curve between the manholes.

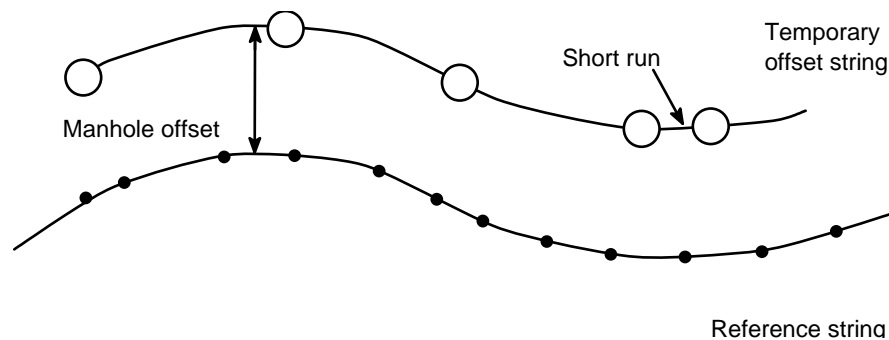


Figure 12 - 2 Offset manholes

IGSEWAT.DAT, SEW003, SEW091

Add/amend manhole	Add offset manholes
Add individual manholes	Reference string
Add offset manholes	Offset
Amend manhole	Linking of M/Hs (T)
Delete manhole	Spacing along (T)
	M/H spacing
	No int M/Hs
	Short run (T)
	U/S M/H label number
	U/S M/H X
	Y
	D/S M/H X
	Y
	Amend manhole details

**Reference string** is the label of the string from which manholes are to be offset.

**Offset** is the offset measured normal to the reference string at which manholes are to be placed. The manholes are placed along an temporary offset string.

**Linking of manholes** is a toggle which determines whether the links between manholes are to be curved or straight. This setting also determines whether the pipe length between manholes is measured along a curved or straight path.

**Spacing along** is a toggle which determines whether the spacing between manholes is measured along the reference string or the temporary offset string.

◇ *Spacing cannot be measured along the reference string when the number of intermediate manholes is specified and the 'Linking of manholes' is set to 'Straight'.*

**Manhole spacing, number of intermediate manholes** and **short run** are inter-dependent fields which determine the number of offset manholes created. There are three cases:

- Manhole spacing specified only. In this case the upstream and downstream manhole positions must be specified and the short run toggle set to either UP or DOWN. The system will then place as many manholes as it needs to cover the length between the upstream and downstream manholes and place the remaining short run adjacent to the downstream or upstream manhole, as indicated by the toggle.
- Number of manholes specified only (only available with curved pipes). In this case the upstream and downstream manhole positions must be specified and the short run toggle is set to N/A (not applicable). The

system will then place the manholes with equal spacing between the upstream and downstream manholes.

- Both spacing and number of manholes specified. In this case, the position of the upstream manhole must be specified. The short run toggle is set to N/A (not applicable).

If you specify a negative spacing, the offset manholes are created in the reverse direction to that of the reference string.

- ◇ *The number of intermediate manholes you specify should not include the upstream and downstream manholes.*

**Upstream manhole label and number** provide the upstream manhole with a unique identifier. The label can be up to four characters long and the number up to four digits long. The number is incremented by one automatically for each of the manholes created downstream.

**Upstream manhole X and Y** determine where the upstream manhole is to be placed and are the coordinates of the nearest point on the offset string to the coordinates you specify.

If you specify an exact point on the reference string, a corresponding point on the offset string will be created.

If you specify any X,Y coordinates, the position of the manhole is calculated by dropping a normal to the offset string.

**Downstream manhole X and Y** determine where the downstream manhole is to be placed and are calculated in a similar way to the upstream manhole coordinates.

**Amend manhole details** allows you to set up or change values associated with manholes, such as shape, construction type etc. The values you specify in this menu are used as defaults when you select Proceed and add details to each offset manhole. The values set up in this menu are similar to those in 'Add offset manhole details'. See 'Add offset manhole details' for further information.

When the manholes have been created and manhole details set up, select Proceed to display the 'Add offset manhole details' menu. Using this menu, you add cover levels and construction details to each manhole in turn until the downstream manhole is reached.

To link the manholes together to form a network branch, use 'Add branch'.

## Add offset manhole details

'Add offset manhole details' allows you to amend the manhole characteristics.

IGSEWAT.DAT, SEW093

Add offset manhole details	
Manhole label	number
Manhole X	Y
Cover Z	Invert Z
Triangulation label	
Shape (T)	
Length	Depth
Cover type (T)	
Construction type (T)	
Bench / Sump (T)	Sump depth
M'Hole/Outfall/Open Jun (T)	
Triangulation label	
Shape (T)	

Starting with the upstream manhole, this menu is displayed for each manhole in turn on the temporary offset string until the downstream manhole is reached.

**Manhole label and number** indicate the offset manhole to be added. The combined label and number must be unique.

**Manhole X and Y** are the coordinates of the offset manhole.

If you wish to reposition the manhole on the temporary offset string, the standard PSMs may be used. The manhole is repositioned on the offset string by dropping a normal to it from the position you specify.

You may also use Point Amend to adjust the position of the manhole forwards or backwards along the temporary offset string.

**Cover Z** is the ground level at the centre of the manhole.

**Invert Z** is the invert level of the outgoing pipe of the manhole.

- ◇ *Manholes are assumed to be benched for design purposes, so that invert levels given for manholes are the same as those for the outgoing pipe.*
- ◇ *When designing a new network, the Invert Z value may be calculated by an external program and may therefore be left blank.*

**Triangulation label** is the label of the triangulation to be used for adding cover levels to the offset manholes. Once the label has been specified, the cover level is automatically inserted for each of the manholes along the temporary offset string in turn.

**Shape** describes the shape of the manhole chamber in plan view.

- ◇ *Pipes are drawn as if connected to circular manholes, no matter what the specified shape of the manhole.*

**Length and width** give the dimensions of the manhole chamber. For circular manholes only length is required which defines the diameter of the circle.

- ◇ *For open junctions and outfalls, the length and width are ignored.*

**Cover type** describes the manhole cover duty.

**Construction type** is the manhole construction material.

**Bench / Sump** describes the manhole invert type. For design purposes, all manholes are assumed to be benched.

**Sump depth** is the depth of the manhole sump if a sump manhole is to be added. It is measured from the outgoing pipe invert to the sump invert.

**Manhole/Outfall/Open Junction** defines the type of structure to be added. Different symbols are used on the network depending upon the structure type.

- ◇ *If offset curved manholes are moved then the resultant links between connecting manholes will be straight as there is no further relation with the reference string.*

## Amend manhole

‘Amend manhole’ is used to reposition an individual manhole or to change its construction details.

IGSEWAT.DAT, SEW003, SEW005

Add/amend manhole	Amend manhole
Add individual manholes	Manhole label number
Add offset manholes	Manhole X Y
Amend manhole	Cover Z
Delete manhole	Invert Z
	Shape (T)
	Length
	Width
	Cover type (T)
	Construction type (T)
	Bench / Sump (T)
	Sump depth
	M'Hole/Outfall/Open Jun (T)

**Manhole label and number** define the manhole to be amended.

You are prompted to select a manhole, following which all the parameters are displayed that were defined in the 'Add individual manholes' menu. After amending any of these parameters, select Proceed to accept them.

- ◇ *If the invert level of a manhole is amended, it does not affect the level of adjoining pipes. See 'Amend pipe details' for details.*
- ◇ *If an offset manhole is selected and its position is changed, then its offset characteristics are removed and it becomes an individual manhole.*
- ◇ *If an offset manhole is selected which is part of a curved branch, if its position is changed then the pipes on either side of the manhole become straight.*

## Delete manhole

'Delete manhole' deletes a manhole from the drainage model.

IGSEWAT.DAT, SEW003, SEW006

Add/amend manhole	Delete manhole
Add individual manholes	Manhole label
Add offset manholes	number
Amend manhole	
Delete manhole	

**Manhole label and number** define the manhole to be deleted.

- ◇ *If a manhole is part of a branch, it must be removed from the branch before it can be deleted. See 'Remove manhole' for details.*

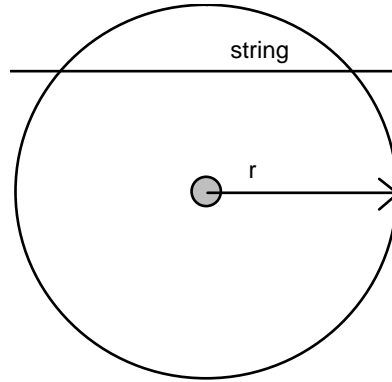
## Manhole proximity check

The drainage proximity check is invoked when you select Proceed from the following menus:

- Add manhole
- Amend manhole

- Move manhole

A clash is calculated by a circle, equal in radius to the clash check distance plus the manhole radius, centred around the manhole position. If a manhole is found to clash with masked strings a warning is displayed and you are offered a new manhole position. You are given the option to accept or to reject this new position.



$r = \text{clash check distance} + \text{manhole radius}$

Figure 12 - 3 A clash between a manhole and a masked string

IGSEWAT.DAT, SEW104

<b>Manhole proximity check</b>
<b>Accept amended position</b>
<b>Accept original position</b>
<b>Respecify manhole</b>

**Accept amended position** automatically creates a manhole at the suggested plan position, then invokes the Amend position levels menu.

**Accept original position** automatically creates the manhole at its original position, then returns to the calling menu.

**Respecify manhole** returns you to the Add individual manhole menu.

◇ *Proceed and Quit are not valid from this menu.*



- ◇ *The thickness of the manhole and the thickness of the pipe are not taken into account when making this calculation.*
- ◇ *Drainage proximity checking can be enabled or disabled using the parameter PROXCHCK in the parameter file. Alternatively you may override this setting from the Proximity check defaults menu.*

## Amend position levels

'Amend position levels' is used to add levels to manholes after a proximity check violation.

If a triangulation model was selected on entry to Drainage, a new level will be taken from this surface.

IGSEWAT.DAT, SEW104, SEW108

Manhole proximity check	Amend position levels
Accept amended position	Manhole (R) X
Accept original position)	Manhole (R) Y
Respecify manhole	Cover Z
	Cover Y

**Manhole X and Y** are the current manhole coordinates.

**Cover Z** is the level of the ground at the centre of the manhole.

**Invert Z** is the manhole invert level.

## Add branch

'Add branch' creates a branch of a network by linking together manholes selected from the screen. Each pipe formed from the links between the manholes has an identifier of the form 'bbb.ppp' where 'bbb' is the branch number and 'ppp' is the pipe number.

A branch may consist of offset manholes, individual manholes or a combination of the two.

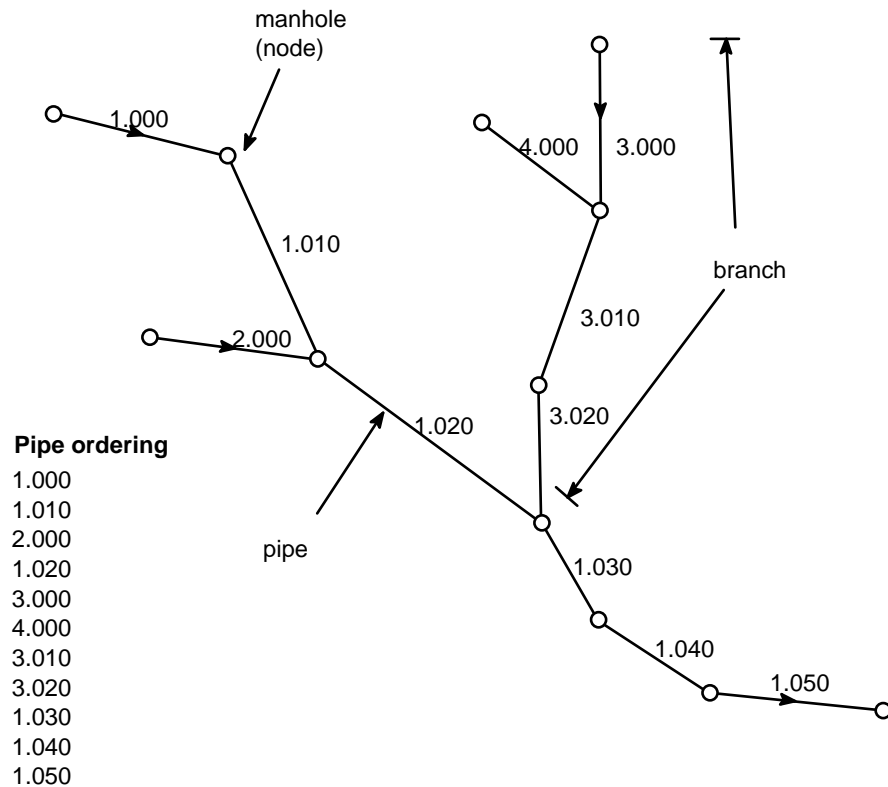


Figure 12 - 4 Example of network pipe ordering

### Individual manholes

The procedure for adding a branch linking individual manholes is as follows:

- Select the manhole that is to be the upstream manhole on the branch. The 'link manhole' field remains highlight.
  - Select the next manhole downstream. A link is formed between the two manholes.
  - Continue to link manholes until the downstream manhole on the branch is reached.
  - Store the links as a branch. The 'link manhole' field is highlight once again ready for linking the next branch.
- ◇ *The branch is created in the direction and order that the manholes are linked.*

**Offset manholes**

The procedure for adding a branch which links offset manholes is as follows:

- Select the manhole that is to be the upstream manhole on the branch. This can be any offset manhole.
  - To link the manholes automatically, select Proceed. All the downstream manholes in the set are linked.
  - To link the manholes manually, select the next manhole downstream. A dotted link is drawn between the manholes. Repeat the process until the last downstream manhole has been reached, or select Proceed to link the remaining manholes automatically.
  - At any stage, you may select Quit a number of times to reject previous links.
  - Store the links as a branch. The 'link manhole' field is highlit once again ready for linking the next branch.
- ◇ *The branch is created in the direction and order that the manholes are linked.*

IGSEWAT.DAT, SEW007, SEW032

Add/Amend branch	Add branch
Add branch	Branch number
Amend branch	Start pipe number
Amend pipe details	Pipe number increment
Delete branch	Amend pipe details
Create 3D string	Abandon linking
	Link manhole
	Store branch

**Branch number** is the number of the branch being defined and increments by one automatically for a new branch.

**Start pipe number** is the number of the first pipe in the branch. Start pipe number is in the range 0 to 100.

**Pipe number increment** is the value by which the pipe number is increased for each pipe leg. The increment can be any value in the range 1 to 100.

**Amend pipe details** changes the construction details used for creating pipes. The details may be changed on a pipe-by-pipe basis *with the*

exception of the pipe channel index so that different details may be used in the same branch.

For further information, refer to the description of the 'Amend pipe details' menu.

**Abandon linking** removes any links between manholes that have not been stored as a branch.

**Link manhole** forms links between selected manholes.

**Store branch** is used to create the branch once the links are in place.

Example

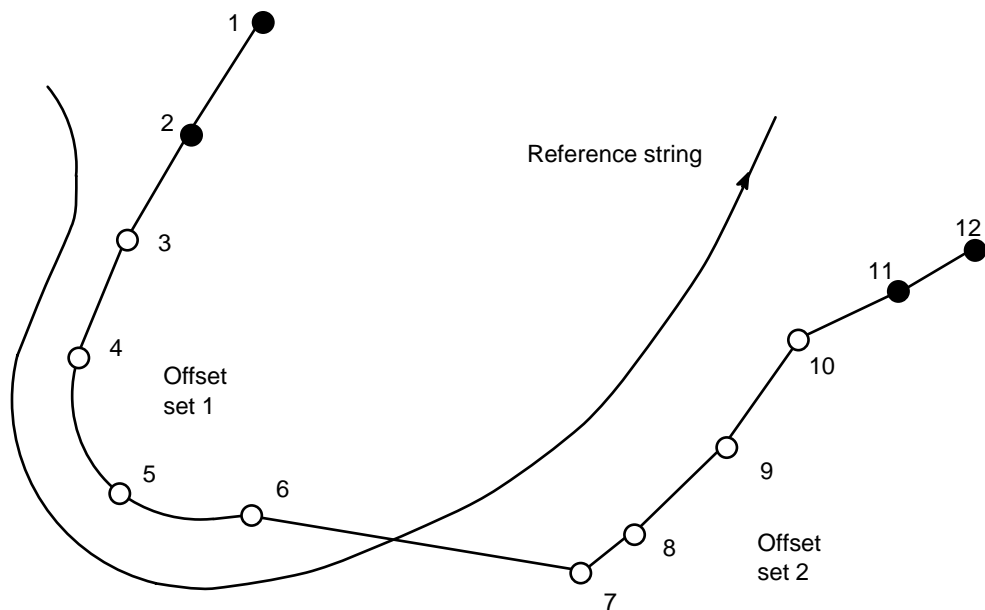


Figure 12 - 5 Offset manholes

In Figure 12 - 5, two sets of offset manholes have been linked with individual manholes to form a single branch.

Offset set 1 contains 4 offset manholes. The upstream and downstream manhole coordinates were specified along with the number of intermediate manholes (2) required. The manholes are therefore equally spaced with curved pipes between the manholes.

Offset set 2 also contains 4 offset manholes. The upstream and downstream manhole coordinates were specified along with the spacing between the manholes. The short run is at the upstream end so that it appears between manholes 7 and 8. The manholes are linked by straight pipes.

## Check branches

The clash checking function is invoked as you link manholes together to form a branch. If a clash is detected then a warning is displayed. The menu below is invoked, allowing you to accept the original position or select a new position.

IGSEWAT.DAT, SEW105

Pipe proximity check
Continue link
Abandon link
Respecify manhole

**Continue link** returns to Add branch without removing any links

**Abandon link** returns to Add branch and removes any links which have not yet been stored.

**Respecify manhole** displays the Respecify manhole position menu and allows you to amend the manhole position before returning to Add branch.

- ◇ *Proceed and Quit are not valid from this menu.*
- ◇ *The thickness of the manhole and the thickness of the pipe are not taken into account when this check is calculated.*

## Respecify manhole position

'Respecify manhole position' allows you to change the plan position of a manhole.

IGSEWAT.DAT, SEW109

Pipe proximity check	Respecify mnhole position
Continue link	Manhole X
Abandon link	Manhole Y
Respecify manhole	Cover Z
	Invert Z

Respecify manhole position
Manhole X
Manhole Y
Cover Z
Invert Z

**Manhole X and Y** are the coordinates of the offset manhole.  
**Cover Z** is the ground level at the centre of the manhole.  
**Invert Z** is the invert level of the outgoing pipe of the manhole.

### Check pipe lengths

The maximum length checking function is invoked as you link manholes together to form a branch. If a pipe exceeds the specified value you will be offered an alternative manhole position, which is displayed with the menu

shown below. You may select the recommended position, proceed with the original position, or select a new position.

IGSEWAT.DAT, SEW106

<b>Pipe length check</b>
<b>Accept amended position</b>
<b>Accept original position</b>
<b>Respecify manhole</b>

**Accept amended position** selects the recommended position and displays the 'Amend position levels' menu to allow you to change the level of the manhole.

**Accept original position** selects the original position and continues with the link manholes operation.

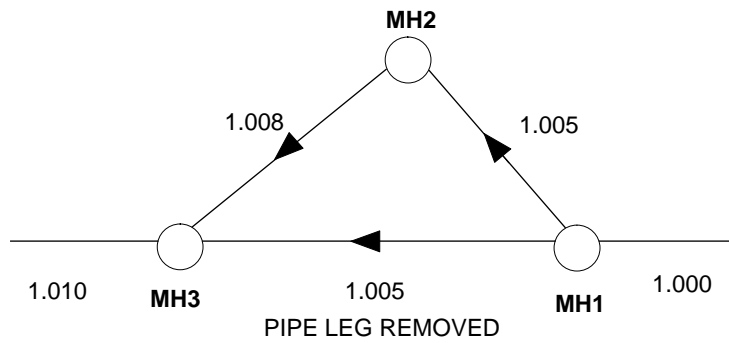
**Respecify manhole** suspends the link manholes operation and displays the 'Respecify manhole position' menu to allow you to respecify the manhole.

## Insert manhole

The 'Insert manhole' facility is used to insert a manhole in to an existing branch, so creating an extra pipe leg. The new manhole can be inserted anywhere within the branch, or at the start or end of the branch.

The new manhole must be either a manhole that is not part of a branch or the most downstream manhole on another branch, ie, a manhole that does not have an outgoing pipe connection.

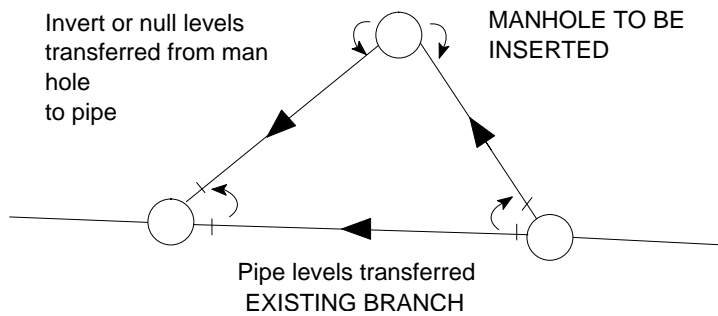
The pipe leg formed by inserting the manhole is automatically labelled according to the existing pipe labelling of the network.



Branch number - 1  
New manhole - MH2  
Precedes  
Extra manhole - MH3

**Figure 12 - 6 Insert manhole – example**

The invert level of the manhole being inserted is given to the adjoining pipes, even if it is a null level. If the pipe leg into which the manhole is inserted has pipe levels, then these are transferred to the new pipe legs at the opposite end to the manhole being inserted.



**Figure 12 - 7 Insert manhole – transfer of levels**



IGSEWAT.DAT, SEW007, SEW009, SEW010

Add/Amend branch	Amend branch	Insert manhole
Add branch	Insert manhole	Branch number
Amend branch	Remove manhole	New MH label number
Amend pipe details	Resequence	Precedes/follows s (T)
Delete branch	Move manhole	Extg MH label number
Create 3D string		

**Branch number** defines the branch into which a manhole is to be inserted.

**New MH label and number** specify the manhole to be inserted.

**Precedes/follows** is a toggle which determines whether the manhole is to be inserted before or after an existing manhole in the branch.

**Extg MH label and number** define a manhole on the branch which the new manhole will precede or follow.

- ◇ *The new pipe legs are given the construction details of the existing pipe. One of the pipe legs is given the number of the old pipe and the other is numbered by splitting the difference between the old pipe number and the adjacent pipe's number.*
- ◇ *If the existing pipes are numbered with an increment of 1, they must be resequenced before a manhole can be inserted. See 'Resequence' for details.*
- ◇ *If a manhole is to be inserted at the start of a branch the branch must be resequenced so that the start pipe number is greater than zero.*
- ◇ *If a manhole is inserted into a curved branch, then the pipes either side of the inserted manhole are straight.*

## Remove manhole

'Remove manhole' removes a manhole from an existing branch (but does not remove the manhole from the model). When removing a manhole, the manholes upstream and downstream of the manhole being removed are automatically connected. The level at the downstream end of the outgoing pipe and the level at the upstream end of the incoming pipe are assigned to the new pipe leg.

- ◇ Use 'Delete manhole' to delete a manhole from the network.

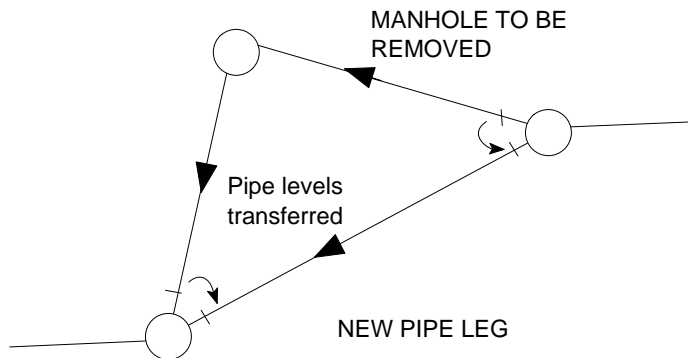


Figure 12 - 8 Remove manhole

IGSEWAT.DAT, SEW007, SEW009, SEW011

Add/amend branch	Amend branch	Remove manhole
Add branch	Insert manhole	Branch number
Amend branch	Remove manhole	Manhole label number
Amend pipe details	Resequence	Associated pipe (T)
Delete branch	Move manhole	
Create 3D string		

**Branch number** defines the branch from which the manhole is to be removed.

**Manhole label and number** define the manhole to be removed from the branch.

**Associated pipe** determines whether pipe details (such as the construction type and pipe size) are transferred from the pipe upstream or downstream of the manhole being removed to the new pipe leg.

- ◇ *The number given to the new pipe leg is that of the pipe upstream of the manhole being removed.*
- ◇ *If an offset manhole is removed from a curved branch, the replacement pipe is straight.*

## Resequence

'Resequence' changes the sequence of pipe numbers in a branch so that the pipe numbers have equal increments.

IGSEWAT.DAT, SEW007, SEW009, SEW012

Add/amend branch	Amend branch	Resequence
Add branch	Insert manhole	Branch number
Amend branch	Remove manhole	Start pipe number
Amend pipe details	Resequence	Pipe number increment
Delete branch	Move manhole	
Create 3D string		

Each pipe has an identifier of the form 'bbb.ppp' where 'bbb' is the branch number and 'ppp' is the pipe number.

**Branch number** is the number of the branch to be resequenced.

◇ *This option is initially displayed independently of the other options in the menu.*

**Start pipe number** is the number of the first pipe in the branch. Start pipe number is in the range 0 to 100.

**Pipe number increment** is the value by which the pipe number is increased at each manhole. The increment can be any value in the range 1 to 100.

## Move manhole

'Move manhole' moves a manhole and the pipe legs connected to the manhole.

IGSEWAT.DAT, SEW007, SEW009, SEW035

Add/amend branch	Amend branch	Move manhole
Add branch	Insert manhole	Manhole label number
Amend branch	Remove manhole	Manhole X Y
Amend pipe details	Resequence	Cover Z
Delete branch	Move manhole	Invert Z
Create 3D string		

**Manhole label and number** define the manhole to be moved.

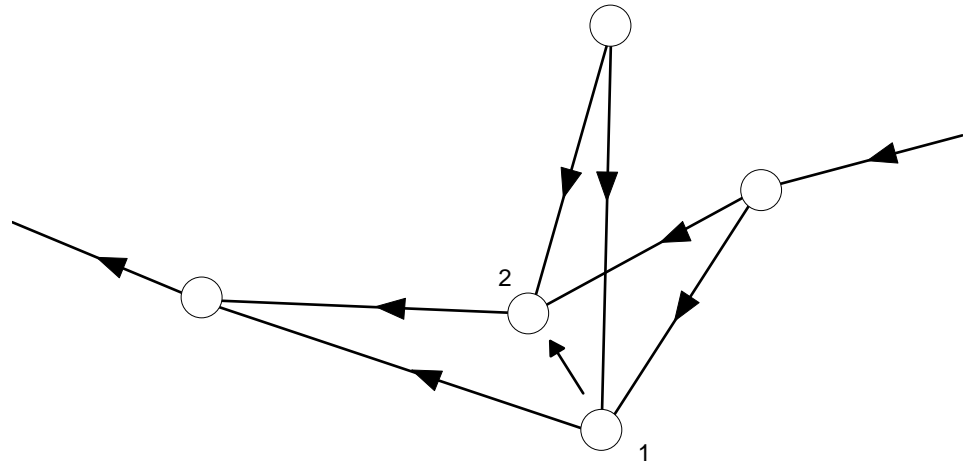
- ◇ *This option is initially displayed independently of the other options in the menu.*

**Manhole X and Y** are the current manhole coordinates.

**Cover Z** is the level of the ground at the centre of the manhole.

**Invert Z** is the manhole invert level.

- ◇ *Both the manhole invert level and the adjoining pipe levels remain unaffected by 'Move manhole'.*
- ◇ *If an offset manhole is moved after it has been created, then its offset characteristics are removed and it becomes an individual manhole. If the manhole is in a curved branch, the pipes joining the manhole become straight.*



ie moving manhole from position 1 to 2,  
the connecting pipe lengths are  
automaticlv adiuusted

Figure 12 - 9 Moving a manhole

## Amend pipe details

‘Amend pipe details’ changes values associated with pipes such as pipe size, level, construction type etc.

IGSEWAT.DAT, SEW007, SEW078

<b>Add/amend branch</b>	<b>Amend pipe details</b>
Add branch	Branch/pipe number
Amend branch	Up stream Z
<b>Amend pipe details</b>	Down stream Z
Delete branch	Pipe channel index
Create 3D string	Pipe channel shape
	Major dimen.
	Minor dimen.
	Roughness (T)
	Value
	Pipe type (T)
	Joint type
	Bed type (T)
	Surround (T)
	D.S. Invert type (T)

**Branch/pipe number** defines the pipe to be amended.

- ◇ *This option is initially displayed independently of the other options in the menu.*

**Up stream Z** is the invert level of the pipe at the upstream manhole.

- ◇ *If this level is amended, it does not change the invert level at the adjoining manhole (see 'Amend manhole').*

**Downstream Z** is the invert level of the pipe at the downstream manhole.

- ◇ *If this level is amended, it does not change the invert level at the adjoining manhole (see 'Amend manhole').*

**Pipe channel index** when Wallrus/MicroRAT is the pre-defined external package pipe channel index selects a table of shapes for the pipe cross-section. Index 0 selects the standard pipe shape table (mainly closed), while Index 1 selects the non-standard pipe shape table (mainly open).

**Pipe channel shape** when Wallrus/MicroRAT is the pre-defined external package pipe channel shape displays the pipe shape table defined by the pipe channel index in the scrolling menu area. Select the desired shape from the table.

- ◇ *For further details of pipe shapes, refer to the WALLRUS documentation.*

**Pipe dimen.** when Micro Drainage is the pre-defined external package 'Pipe dimen.' replaces 'Major and Minor dimen'. The pipe dimension is required only when the 'Pipe shape code' is 0 (a circular pipe), and the value entered is the major dimension in mm or inches.

**Pipe shape code (R)** when Micro Drainage is the pre-defined external package 'Pipe channel shape' is replaced by the read only field 'Pipe shape code'. The pipe shape code is a value between 0 and 65, for a full description of the shape associated with each code see the Micro Drainage documentation.

**Major dimen.** is the major pipe cross-section dimension.

**Minor dimen.** is the minor pipe cross-section dimension.

**Roughness** is a toggle which indicates whether the pipe roughness is specified as equivalent sand roughness  $k_s$  or as  $1/n$ , where 'n' is Mannings coefficient.

**Roughness** is a toggle which indicates whether the pipe roughness is specified as equivalent sand roughness  $k_s$  or as  $1/n$ , where 'n' is Mannings coefficient. When Micro Drainage is the pre-defined external package, you can only specify roughness as  $K_s$  (mm/ft).

**Value** is the roughness value in the range 0.6 to 600 ( $k_s$ ) or 5 to 83 ( $1/n$ ).

**Pipe type** describes the pipe construction material.

**Joint type** describes the pipe jointing method.

**Bed type** describes the pipe bedding material.

**Surround** describes the pipe surround material.

**D.S. Invert type** defines the type of connection between the pipe and the downstream manhole.

**Number of houses per pipe** is an optional value required for Foul design only when Micro Drainage is the pre-defined external package.

## Delete branch

'Delete branch' deletes all the pipes from a network branch in the drainage model.

IGSEWAT.DAT, SEW007, SEW015

Add/amend branch	Delete branch
Add branch	Branch number
Amend branch	
Amend pipe details	
Delete branch	
Create 3D string	

**Branch number** is the number of the branch to be deleted.

- ◇ *The remaining manholes may be deleted using 'Delete manhole' if required.*

## Create 3D string

'Create 3D string' creates a 3D string from a network branch.

IGSEWAT.DAT, SEW007, SEW085

Add/amend branch	Create 3D string
Add branch	Receiving model
Amend branch	New string label
Amend pipe details	Branch number
Delete branch	Start manhole number
Create 3D string	End manhole number

**Receiving model** is the name of the model to contain the created string.

◇ *If the model does not exist, a new one is automatically created.*

**New string label** is the label of the created string.

**Branch number** is the number of the branch from which the string is created.

**Start manhole label and number** define the first point on the string.

**End manhole label and number** define the last point on the string.

◇ *If the start and end manholes are left blank, a string is created for the full branch.*

◇ *If the start and end manholes are the same, a single point string is created.*

## Add gully

‘Add gully’ creates a gully with the specified characteristics.

Gullies should only be added when a network containing manholes and branches has been analysed by WALLRUS. This is because gullies are not tied in to the main network so if a change is made to the network, the gullies may no longer be in the correct position.



IGSEWAT.DAT, SEW016, SEW017

Add/amend gully	Add gully
Add gully	Gully label number
Amend gully	Gully X Y
Delete gully	Gully grd Z
	Surface adj
	Gully cover Z
	Outlet depth
	Outlet invt Z
	Junction X Y
	Junction Z
	Pipe size (T)
	Pipe type (T)
	Joint type (T)
	Bed type (T)
	Surround (T)
	D/S inv ty (T)

**Gully label and number** provide the gully with a unique identifier. The label can be up to four characters long and the number up to four digits long.

**Gully X and Y** define the position of the gully.

**Gully grd Z** defines the ground level at the gully.

- ◇ *The point selection method TRIGXY automatically calculates the level at any point by interpolating values from the triangulation model. By using this PSM, the gully x and y coordinates and the ground level are defined together.*

**Surface adj** is the surface adjustment height which is the distance from the road surface level to the gully cover level.

**Gully cover Z** is the level of the gully cover.

**Outlet depth** is the distance from the gully cover to the outlet pipe invert.

**Outlet invert Z** is the invert level of the outlet.

**Junction X, Y and Z** define the position and level of the junction between the gully pipe and the network branch.

- ◇ *The gully pipe can join the network at a manhole or a pipe leg.*
- ◇ *The point selection method NORM is used to ensure that the gully pipe meets a pipe exactly and returns the invert level of the pipe at the connection.*

*Check NORM PSM is selected.*

*Select the network branch to be joined by the gully pipe.*

*Ensure curve fitting is off.*

*Select XY PSM.*

*Select a point near the network branch.*

*If the gully pipe connects at a manhole, select POINT PSM rather than NORM PSM.*

**Pipe size** is the diameter of the pipe joining the gully to the network branch.

**Pipe type** describes the gully pipe construction material.

**Joint type** describes the jointing method used in the gully pipe.

**Bed type** describes the pipe bedding material.

**Surround** describes the pipe surround material.

**D.S. Invert type** defines the type of connection between the gully pipe and the network branch.

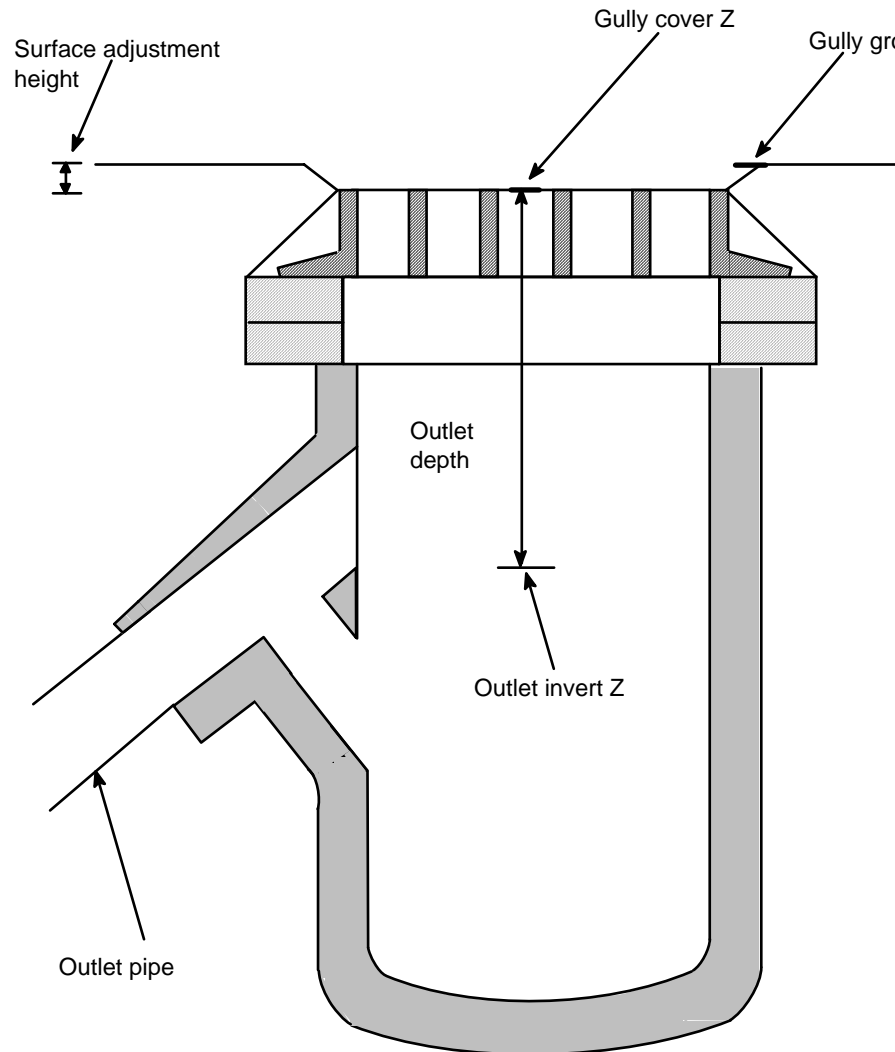


Figure 12 - 10 Gully dimensions

## Amend gully

IGSEWAT.DAT, SEW016, SEW018

Add/amend gully	Amend gully
Add gully	Gully label number
Amend gully	Gully X Y
Delete gully	Gully grd Z
	Surface adj
	Gully cover Z
	Outlet depth
	Outlet invt Z
	Junction X Y
	Junction Z
	Pipe size (T)
	Pipe type (T)
	Joint type (T)
	Bed type (T)
	Surround (T)
	D/S inv ty (T)

**Gully label and number** define the gully to be amended.

You will be prompted to select a gully, following which all the parameters are displayed that were defined in the 'Add gully' menu. After amending any of these parameters, select Proceed to accept them. See 'Add gully' for details.

## Delete gully

'Delete gully' deletes a gully from the drainage model.

IGSEWAT.DAT, SEW016, SEW019

Add/amend gully	Delete gully
Add gully	Gully label
Amend gully	number
Delete gully	

**Gully label and number** define the gully to be deleted.

### Manhole defaults

'Manhole defaults' allows construction details for manholes to be changed.

IGSEWAT.DAT, SEW020, SEW021

Construction defaults	Manhole defaults
Manhole defaults	Manhole shape (T)
Pipe defaults	Length
Gully defaults	Width
Proximity check defaults	Cover type (T)
	Construction type (T)
	Bench / Sump (T)
	Sump depth

**Manhole shape** describes the shape of the manhole chamber.

**Length and width** give the dimensions of the manhole chamber in plan view. For circular manholes only the length is required which defines the diameter of the circle.

◇ *For open junctions and outfalls, the length and width are ignored.*

**Cover type** describes the manhole cover duty.

**Construction type** describes the manhole construction material.

**Bench / Sump** describes the manhole invert type. For design purposes, all manholes are assumed to be benched.

**Sump depth** is the depth of the manhole sump if sump manholes are to be used. It is measured from the outgoing pipe invert to the sump invert.

## Pipe defaults

‘Pipe defaults’ allows construction details for pipes to be changed.

IGSEWAT.DAT, SEW020, SEW082

Construction defaults	Pipe defaults
Manhole defaults	Pipe channel index (T)
Pipe defaults	Pipe channel shape (T)
Gully defaults	Roughness Value
Proximity check defaults	Pipe type (T)
	Joint type (T)
	Bed type (T)
	Surround (T)
	D.S. Invert type (T)
	Pipe measurement (T)

**Pipe channel index** when Wallrus/MicroRAT is the pre-defined external package pipe channel index selects a table of shapes for the pipe cross-section. Index 0 selects the standard pipe shape table (mainly closed), while Index 1 selects the non-standard pipe shape table (mainly open).

**Pipe channel shape** when Wallrus/MicroRAT is the pre-defined external package pipe channel shape displays the pipe shape table defined by the pipe channel index in the scrolling menu area. Select the desired shape from the table.

◇ *For further details of pipe channel shapes, refer to the WALLRUS documentation.*

**Pipe shape code (R)** when Micro Drainage is the pre-defined external package ‘Pipe channel shape’ is replaced by the read only field ‘Pipe shape code’. The pipe shape code is a value between 0 and 65, for a full description of the shape associated with each code see the Micro Drainage documentation.

**Roughness** is a toggle which indicates whether the pipe roughness is specified as equivalent sand roughness  $k_s$  or as  $1/n$ , where 'n' is Mannings coefficient. When Micro Drainage is the pre-defined external package, you can only specify roughness as  $Ks_s$  (mm/ft).

**Value** is the roughness value in the range 0.6 to 600 ( $k_s$ ) or 5 to 83 ( $1/n$ ).

**Pipe type** describes the pipe construction material.

**Joint type** describes the pipe jointing method.

**Bed type** describes the pipe bedding material.

**Surround** describes the pipe surround material.

**D.S. Invert type** defines the type of connection between the pipe and the downstream manhole.

**Pipe measurement** defines how pipe lengths are measured. MH edge (default) means that pipes are measured from manhole edge to manhole edge. MH centre means that pipes are measured from manhole centre to manhole centre.

This setting will affect reporting of branches and pipes, and the drawing and length annotation of pipes in Major option DRAW.

The advantage of centre to centre measurement is the calculation of a true hydraulic gradient for network design and analysis.

◇ *Changing from edge to centre measurement will affect existing pipe lengths and gradients in the current drainage model.*

**Number of houses per pipe** is an optional value required for Foul design only when Micro Drainage is the pre-defined external package.

## Gully defaults

'Gully defaults' allows construction details for gullies to be changed.

IGSEWAT.DAT, SEW020, SEW024

Construction defaults	Gully defaults
Manhole defaults	Surface adjstmnt hght
Pipe defaults	Depth to outlet invert
Gully defaults	Pipe size (T)
Proximity check defaults	Pipe type (T)
	Joint type (T)
	Bed type (T)
	Surround (T)
	D/S inv ty (T)

**Surface adjustment height** is the distance from the road surface level to the gully cover level.

**Depth to outlet invert** is the distance from the gully cover to the outlet pipe invert.

**Pipe size** is the diameter of the pipe joining the gully to the network branch.

**Pipe type** describes the gully pipe construction material.

**Joint type** describes the jointing method used in the gully pipe.

**Bed type** describes the pipe bedding material.

**Surround** describes the pipe surround material.

**D.S. Invert type** defines the type of connection between the gully pipe and the network branch.

### Proximity check defaults

This allows you to change the default values for clash detection. If you make any amendments here they will override the parameter values for the duration of the current MOSS session.

IGSEWAT.DAT, SEW020, SEW107

Construction defaults	Proximity check defaults
Manhole defaults	Proximity check (T)
Pipe defaults	Manhole check distance
Gully defaults	Nominal pipe size
Proximity check defaults	Pipe length check (T)
	Length check distance
	String masking (T)
	String mask 1
	String mask 2
	String mask 3
	String mask 4

**Proximity check** allows you to switch the manhole and branch proximity with carriageway check on and off.

**Manhole check distance** allows you to set the minimum distance for the manhole proximity check.

**Pipe check distance** allows you to set the minimum distance for the drainage pipe proximity check.

**Nominal pipe size** allows you to set a value for the nominal pipe.

**Pipe length check** allows you to switch the drainage pipe length check on and off.

**Length check distance** allows you to set the maximum distance for the drainage pipe length check.

**String masking** allows you to apply string masking to the check manholes and check branch functions. Default masks are defined in the parameter file.

**String masks 1, 2, 3 and 4** allow you to select the strings to be included in the mask.

## Area calculations

The sub-catchment area which drains in to each pipe can be determined by using triangulation or boundary methods. Sub-catchments are divided into pervious and impervious areas to calculate surface runoff.

When using Wallrus, paved and pitched roof areas within the impervious area may be calculated separately if required.

The sub-catchment area which drains in to each pipe can be determined by using triangulation or boundary methods. Sub-catchments are divided into pervious and impervious areas to calculate surface runoff. Within the impervious area, paved and pitched roof areas may be calculated separately if required.

When using MicroRAT, paved and roofed areas are not distinguished and so the roof area need not be specified separately.

When using Micro Drainage, roofed areas are not an option. A different menu from that shown below is used to allow the paved area to be specified as a fraction of the total area or as an actual value. When passing area data to Micro Drainage, the paved area is required as a fraction of the total area and so, if an actual value has been specified, automatic translation from actual value to fraction is performed as part of the data transfer.

- ◇ *For further details of calculating areas, refer to the WALLRUS documentation.*
- ◇ *Areas are calculated in hectares (metric) or acres (imperial) dependent on the units set in the MOSS parameter file prmdef.dat.*
- ◇ *Areas are not transferred from Micro Drainage to MOSS.*



IGSEWAT.DAT, SEW002, SEW059, SEW067

Drainage design	Area calculations
Add/amend manhole	Branch/pipe
Add/amend branch	Area Analyse/Estimate (T)
Add/amend gully	Total area (ha/acres)
Construction defaults	Impervious area (ha/acres)
Area calculations	Roof area (ha/acres)
Drainage analysisMOSS to Drainage analysis	
MOSS Drainage FormatDrainage analysis to MOSS	
Drawing management	
Report network	
Copy drainage model	

**Branch/pipe** is the label of the pipe into which the sub catchment is drained.

◇ *If areas for the specified pipe exist already, these are displayed in the appropriate fields.*

**Area Analyse/Estimate** is a toggle to indicate whether the sub catchment areas are to be calculated or estimated.

If the areas are to be estimated, values for 'Total area', 'Impervious area' and 'Roof area' (if required) should be entered from the keyboard when the relevant menu option is highlighted. Any values entered as estimated areas overwrite any existing areas stored on the current branch/pipe. Therefore, in order to remove any stored areas, an estimated value of zero may be entered.

If areas are to be analysed, selecting 'Total area', 'Impervious area' and 'Roof area' causes appropriate sub–menus to appear.

**Total area** is the total area of the sub catchment draining into the specified pipe.

◇ *Total area must be calculated before impervious or roof areas.*

**Impervious area** is the impervious area within the sub–catchment, **excluding the pitched roof area** if this is to be calculated separately.

◇ *Impervious area which drains into pervious area rather than the network should not be included.*

**Roof area** is the pitched roof area within the sub catchment.

◇ *Flat roof area should be included in the impervious area percentage.*

- ◇ *Pitched roof area need only be calculated separately if more than 30% of the impervious area is pitched roof connected directly into the network.*
- ◇ *Roof area is only considered separately in 'UK format' and when the Hydrograph or Simulation methods are used. See 'System Control Parameters' for details.*

When the areas required have been analysed or calculated, the totals displayed on the menu can be stored in the model by selecting Proceed.

Once the totals have been stored, they are cleared from the menu to allow sub catchment areas for subsequent pipes to be calculated.

Selecting Quit at this stage exits the menu and loses any areas that have not been stored.

**Paved area** is displayed when Micro Drainage is the pre-defined external package. 'Total area', 'Impervious area' and 'Roof area' are not appropriate. The paved area toggle allows you to select either 'factor of total area' or 'actual paved area'. The paved area may then be specified either as a factor in the range 0 to 1, or as an actual paved area value in hectares.

## Total area

### Total area

IGSEWAT.DAT, SEW059, SEW060

Area calculations	Total area analysis
Branch/pipe	Branch/pipe
Area Analyse/Estimate (T)	Area inside boundary
Total area (ha/acres)	Area by group code
Impervious area (ha/acres)	Area by seeding
Roof area (ha/acres)	Area by picking triangles
	Cumulative area

**Branch/pipe** displays the label of the pipe into which the sub catchment area is drained.

**Area inside boundary** calculates the area within a boundary string.

**Area by group code** calculates the area of a group of triangles having a common group code assigned to them.

**Area by seeding** calculates the area using triangle seeding.

**Area by picking triangles** calculates the area covered by triangles selected from the screen.

**Cumulative area** is the total of the areas already calculated.

Selecting Quit at this stage returns you to the previous menu retaining the cumulative area.

## Area inside boundary

IGSEWAT.DAT, SEW059, SEW060, SEW063

Area calculations	Total area analyse	Area inside boundary
Branch/pipe	Branch/pipe	Boundary string label
Area Analyse/Estimate (T)	Area inside boundary	label
Total area (ha/acres)	Area by group code	Hatching switch (T)
Impervious area (ha/acres)	Area by seeding	Area (+/-) (T)
Roof area (ha/acres)	Area by picking triangles	Current area
	Cumulative area	Cumulative area

**Boundary string** is the label of the boundary string surrounding the area.

**Hatching switch** is a toggle which determines whether the displayed hatching is stored in the DPF, retained until the end of DRAINAGE or temporarily displayed until the current area has been calculated.

◇ *If the hatching switch is set to 'Store', any hatching previously displayed with 'Temp' or 'Retain' will be deleted.*

**Area (+/-)** is a toggle to indicate whether the area being calculated is to be added or subtracted from the cumulative area.

**Current area** displays the calculated area.

**Cumulative area** displays the sum of the current areas already calculated.

Selecting Proceed adds the current area to the cumulative area field. More areas can then be calculated and added to the cumulative area in a similar manner.

Once all areas have been calculated, selecting Quit first removes the auto-highlight from the relevant field and, on reselection, returns to the previous menu retaining the cumulative area.

## Area by group code

IGSEWAT.DAT, SEW059, SEW060, SEW064

Area calculations	Total area analyse	Area by group code
Branch/pipe	Branch/pipe	Triangulation label
Area Analyse/Estimate (T)	Area inside boundary	Group code
Total area (ha/acres)	Area by group code	Hatching switch (T)
Impervious area (ha/acres)	Area by seeding	Area (+/-) (T)
Roof area (ha/acres)	Area by picking triangles	Current area
	Cumulative area	Cumulative area

**Triangulation label** is the label of the triangulation string to be used for calculating the area.

**Group code** is the previously assigned label which identifies the triangle group.

**Hatching switch** is a toggle which determines whether the displayed hatching is stored in the DPF, retained until the end of DRAINAGE or temporarily displayed until the current area has been calculated.

◇ *If the hatching switch is set to 'Store', any hatching previously displayed with 'Temp' or 'Retain' will be deleted.*

**Area (+/-)** is a toggle to indicate whether the area being calculated is to be added or subtracted from the cumulative area.

**Current area** displays the calculated area.

**Cumulative area** displays the sum of the current areas already calculated. Selecting Proceed adds the current area to the cumulative area field. More areas can then be calculated and added to the cumulative area in a similar manner.

Once all areas have been calculated, selecting Quit first removes the auto-highlight from the relevant field and, on reselection, returns to the previous menu retaining the cumulative area.

## Area by seeding

IGSEWAT.DAT, SEW059, SEW060, SEW065

Area calculations	Total area analyse	Area by seeding
Branch/pipe	Branch/pipe	Triangulation label
Area Analyse/Estimate (T)	Area inside boundary	Assign group code
Total area (ha/acres)	Area by group code	Dummy link creation (T)
Impervious area (ha/acres)	Area by seeding	Define string masking
Roof area (ha/acres)	Area by picking triangles	Link tolerance (T)
	Cumulative area	Hatching switch (T)
		First triangle
		Show ungrouped triangles
		Area (+/-) (T)

**Triangulation label** is the label of the triangulation string to be used for calculating the area.

**Assign group code** gives a code to the group of triangles to be seeded (optional).

◇ *If it is used, the group code must be assigned before triangles are seeded.*

**Dummy link creation** is used to add links from the triangulation in order to limit seeding.

◇ *Dummy links are drawn in yellow.*

**String masking** specifies a string mask to be used by the seeding process.

The **link tolerance** is the minimum length a triangle side can be without being a dummy link; in other words, triangle sides shorter than the link tolerance are not considered for further seeding. See 'Dummy links' in major option TRIANGLE for further details.

**Hatching switch** is a toggle which determines whether the displayed hatching is stored in the DPF, retained until the end of DRAINAGE or temporarily displayed until the current area has been calculated.

◇ *If the hatching switch is set to 'Store', any hatching previously displayed with 'Temp' or 'Retain' will be deleted.*

**First triangle** is the triangle to be used as the initial seeding triangle.

◇ *Refer to major option TRIANGLE for details of triangle grouping using seeding.*

**Show ungrouped triangles** highlights all the triangles which do not currently belong to a group.

**Area (+/-)** is a toggle to indicate whether the area being calculated is to be added or subtracted from the cumulative area.

**Current area** displays the calculated area.

**Cumulative area** displays the sum of the current areas already calculated.

Selecting Proceed adds the current area to the cumulative area field. More areas can then be calculated and added to the cumulative area in a similar manner.

Once all areas have been calculated, selecting Quit first removes the auto-highlight from the relevant field and, on reselection, returns to the previous menu retaining the cumulative area.

## Area by picking triangles

IGSEWAT.DAT, SEW059, SEW060, SEW066

Area calculations	Total area analyse	Area by picking triang
Branch/pipe	Branch/pipe	Triangulation label
Area Analyse/Estimate (T)	Area inside boundary	Assign group code
Total area (ha/acres)	Area by group code	Hatching switch (T)
Impervious area (ha/acres)	Area by seeding	Add triangle to area
Roof area (ha/acres)	Area by picking triangles	Remove triangle from area
	Cumulative area	Area (+/-) (T)
		Current area
		Cumulative area

**Triangulation label** is the label of the triangulation string to be used for calculating the area.

**Assign group code** gives a code to the group of triangles to be seeded (optional).

**Hatching switch** is a toggle which determines whether the displayed hatching is stored in the DPF, retained until the end of DRAINAGE or temporarily displayed until the current area has been calculated.

◇ *If the hatching switch is set to 'Store', any hatching previously displayed with 'Temp' or 'Retain' will be deleted.*

**Add triangle to area** is used to add a triangle to the area by selecting it from the screen.

**Remove triangle from area** is used to remove a triangle from the area by selecting it from the screen.

**Area (+/-)** is a toggle to indicate whether the area being calculated is to be added or subtracted from the cumulative area.

**Current area** displays the calculated area.

**Cumulative area** displays the sum of the current areas already calculated.

Selecting Proceed adds the current area to the cumulative area field. More areas can then be calculated and added to the cumulative area in a similar manner.

Once all areas have been calculated, selecting Quit first removes the auto-highlight from the relevant field and, on reselection, returns to the previous menu retaining the cumulative area.

## Impervious area

IGSEWAT.DAT, SEW059, SEW061

Area calculations	Impervious area analyse
Branch/pipe	Branch/pipe
Area Analyse/Estimate (T)	Area inside boundary
Total area (ha/acres)	Area by group code
Impervious area (ha/acres)	Area by seeding
Roof area (ha/acres)	Area by picking triangles
	Cumulative area

The menu options used in calculating the impervious area are the same as those used for the total area. See 'Total area' for details.



## Roof area

IGSEWAT.DAT, SEW059, SEW062

Area calculations	Roof area analyse
Branch/pipe	Branch/pipe
Area Analyse/Estimate (T)	Area inside boundary
Total area (ha/acres)	Area by group code
Impervious area (ha/acres)	Area by seeding
Roof area (ha/acres)	Area by picking triangles
	Cumulative area

The menu options used in calculating the roof area are the same as those used for the total area. See 'Total area' for details.

- ◇ *Record type 4 UK format must be selected if roof areas are to be used. See 'System control parameters' for details.*
- ◇ *When leaving WALLRUS and re-entering MOSS, data for use by WASSP should be selected when using roof areas.*

## Drainage analysis - Micro Drainage

IGSEWAT.DAT, SEW086

Drainage analysis
Data to Micro Drainage
Data from Micro Drainage
Invoke Micro Drainage

**Data to Micro Drainage** creates a Micro Drainage file. The file contains both hydraulic and construction data.

**Data from Micro Drainage** loads a file created by Micro Drainage into MOSS.

**Invoke Micro Drainage** starts the Micro Drainage program, which will run alongside MOSS provided it is available and supported by your system. When you exit Micro Drainage, you are returned to the 'Data from Micro Drainage' menu.

## Data to Micro Drainage

IGSEWAT.DAT, SEW086, SEW097

Drainage analysis	Data to Micro Drainage
Data to Micro Drainage	File name
Data from Micro Drainage	Job title
Invoke Micro Drainage	Storm/Foul (T)
	Output invert levels (T)
	Output pipe sizes (T)
	Output 1/3, 2/3 levels (T)
	Invoke Micro Drainage (T)

**Filename** is the name of the .sws or .fws Micro Drainage file to be created. If no file name is specified, either MOSS.sws or MOSS.fws is used, depending on the Storm/Foul toggle setting.

**Job title** the default job title is derived from the full drainage model name. The job title may be changed when the data is saved in Micro Drainage.

**Storm/Foul** this toggle defines the file name suffix. Storm files (.sws) can be analysed by the Rational method in Micro Drainage, and foul files (.fws) can be analysed by the Foul method in Micro Drainage.

**Output invert levels** this toggle defines whether invert levels are included in the Micro Drainage file.

**Output pipe sizes** this toggle defines whether pipe sizes are included in the Micro Drainage file.

**Output 1/3, 2/3 levels** this toggle defines whether 1/3 and 2/3 levels are included in the Micro Drainage file. Micro Drainage has the optional facility to include ground levels at one third and two thirds of each pipe length during the design process. To provide these levels a triangulation model must be specified. Although these levels are not automatically included in the Rational method they do provide a warning against minimum cover in the Schedule program.

**Invoke Micro Drainage** this toggle defines whether Micro Drainage is started when the data is created. When you exit Micro Drainage, you are returned to the 'Data from Micro Drainage' menu.

## Data from Micro Drainage

IGSEWAT.DAT, SEW086, SEW098

Drainage analysis	Data from Micro Drainage
Data to Micro Drainage	File name
Data from Micro Drainage	Storm/Foul (T)
Invoke Micro Drainage	Receiving model (R)
	Redraw network (T)
	Resize manholes (T)
	Update pipe shapes (T)

**Filename** is the name of the .sws or .fws Micro Drainage file to be input. If no file name is specified, MOSS.sws or MOSS.fws is used.

**Storm/Foul** this toggle defines the file name suffix. Storm files (.sws) or foul files (.fws).

**Receiving model** is the drainage model to receive the Micro Drainage file. This must be the model from which the Micro Drainage file was originally created.

**Redraw network** this toggle is used to redraw the network with the new information supplied by Micro Drainage.

**Resize manholes** this toggle defines whether the manholes sizes in the original drainage model are to be updated with information from Micro Drainage.

**Update pipe shapes** this toggle defines whether the pipe shapes in the original drainage model are to be updated with information from Micro Drainage.

## Drainage analysis - Wallrus

'Drainage analysisMOSS to Drainage analysis' is used to pass drainage information to an external file and to invoke an external drainage program such as WALLRUS.

IGSEWAT.DAT, SEW002, SEW042

Drainage design	Drainage analysis
Add/amend manhole	Data to Wallrus
Add/amend branch	Data from Wallrus
Add/amend gully	Invoke Wallrus
Construction defaults	Invoke external program
Area calculations	
Drainage analysis	
MOSS Drainage Format	
Drawing management	
Report network	
Copy drainage model	

**Data to WallrusSSD** creates an SSD file from the single network held in the drainage model.

**Data from Wallrus** loads an SSD file created in Wallrus. Additional and modified information is incorporated into a rebuilt drainage model.

**Invoke WALLRUS** invokes the WALLRUS program. When you exit WALLRUS, you are returned to the 'Data from WallrusDrainage analysis to MOSS' menu.

**Data to MDF** creates an MDF file from the information held in the drainage model. The MDF file contains both hydraulic and construction data from the drainage model. This allows external programs to perform calculations using the data and the entire drainage network to be reconstructed if required.

◇ *For details of the MDF file data format, refer to the beginning of this chapter.*

**Invoke external program** invokes an external program via the procedure msexternal.com. When you exit the program, you are returned to the 'Data from MOSS Drainage Format'MDF' menu.

In order for your external program to be invoked when you select this field, you must edit the procedure msexternal.com so that it starts up your external program in the way you require.

For details of how to start your external program, refer to the documentation supplied.

## Data to WallrusSSD

IGSEWAT.DAT, SEW042, SEW09989

MOSS to drainage analysis	Drainage analysis	Data to WallrusSSD
Data to WallrusSSD		File name
Data from Wallrus		Job title
Invoke Wallrus		Output invert pipe levels (T)
Data to MDF		rOutput pipe sizes (T)
Invoke external program		System control parameters

**File name** is the name of the sewer system data (SSD) file to be created for WALLRUS. If no file name is specified, MOSS.SSD is used.

- ◇ *Within MicroRAT the suffix .SSD must be explicitly specified because MicroRAT expects to use a .RSD file by default.*

**Job title** is the title written in the first record of the SSD file and is normally used to describe the scheme or project.

**Output invertpipe levels** is a toggle to indicate whether invertpipe levels are to be passed to WALLRUS (if they exist) or whether WALLRUS will calculate the invertpipe levels itself.

**Output pipe sizes** is a toggle to indicate whether pipe sizes are to be passed to WALLRUS (if they exist) or whether WALLRUS will calculate the pipe sizes itself.

**System control parameters** allows parameter defaults to be changed. See the 'System control parameters - Wallrus' menu for details.

- ◇ *All branches in the drainage model must be connected as one dendritic network before the SSD file is created.*

## Data to MDF

IGSEWAT.DAT, SEW042, SEW090

MOSS to drainage analysis	Drainage analysis	Data to MDF
Data to SSD		File name
Invoke WALLRUS		Job title
Data to MDF		System control parameters
Invoke external program		MDF level (T)
		Output header details (T)
		Output manhole details (T)
		Output network details (T)
		Output pipe details (T)
		Output gully details (T)

**File name** is the name of the MOSS Drainage file (MDF) to be created. If no file name is specified, MOSS.MDF is used.

**Job title** is the title written in the second record of the MDF file and is normally used to describe the scheme or project.

**System control parameters** allows parameter defaults to be changed. See the 'System control parameters' menu for details.

MDF level is a toggle which determines the level of detail written out to the MDF file. Data in the file may be commented with descriptions from the comment file *mdfdes.dat* and compressed, depending upon the level selected.

- Level 1      Non-commented, compressed.  
No comments are added and only records with data items are written.
- Level 2      Fully commented, compressed  
Comments are added from the comment file and only records with data items are written.
- Level 3      Non-commented, uncompressed.  
No comments are added but all records are written, even those with blank data items.
- Level 4      Fully commented, uncompressed  
Comments are added from the comment file and all records are written, even those with blank data items.

**Output header details** is a toggle which determines whether system control parameter data is written to sections 100, 110 and 120 in the MDF.

**Output manhole details** is a toggle which determines whether manhole data is written to section 200 in the MDF.

**Output network details** is a toggle which determines whether network data is written to section 300 in the MDF.

**Output pipe details** is a toggle which determines whether pipe data is written to section 400 in the MDF.

**Output gully details** is a toggle which determines whether gully data is written to section 500 in the MDF.

- ◇ *For details of the MDF file data format, refer to 'MOSS Drainage File' at the beginning of this chapter.*



## System control parameters - Wallrus

This menu is used to define global WALLRUS information to be contained in the .SSD file.

IGSEWAT.DAT, SEW070

System control parameters
Major time step (sec)
UK/ or International format (T)
Soil index/SCS depth
Soil index value
Global DWF (m <sup>3</sup> /s)
Design pipe sizes (T)
Diameter not decrease (T)
Minimum pipe diameter
Baxter index
Index date

**Major time step** is used by WALLRUS (Hydrograph and Simulation methods) to determine the interval at which levels and discharges are calculated. The time step should be in the range 10 to 120 seconds.

**UK or International format** is a toggle to indicate whether data is passed to WALLRUS in UK or International format (ie, record types 4 or 18).

**Soil index/SCS depth** is a toggle to indicate whether the Wallingford runoff model or the Soil Conservation Service runoff model is to be used.

◇ *SCS depth can only be used with record type 18, international format.*

**Soil index value/SCS depth value** gives an indication of the ability of soil to absorb water.

**Global DWF** defines the dry weather flow in m<sup>3</sup>/s.

**Design pipe sizes** is a toggle to indicate whether pipe sizes are to be designed by WALLRUS or not.

**Diameter not decrease** is a toggle to indicate whether or not pipes are allowed to decrease in diameter downstream.

**Minimum pipe diameter** is the smallest diameter in mm to be allowed for pipes in the network design.

**Baxter index** is a value used for inflation adjustment of cost estimates.

**Index date** is the date to which the Baxter index refers.

◇ *Only the Global DWF and UK/International format parameters are relevant for MicroRAT.*

◇ *The values set in this menu may be passed to the MOSS Drainage File.*

## Data from Wallrus

IGSEWAT.DAT, SEW042, SEW100

Drainage analysis	Data from Wallrus
Data to Wallrus	SSD file name
Data from Wallrus	Receiving model
Invoke Wallrus	Redraw network (T)

**SSD filename** is the name of the SSD file to be input to MOSS. If no file name is specified, MOSS.SSD is used.

◇ *A new sewer data file created by the Hydrograph method has the suffix .NEW. In this case, the file name must include the .NEW suffix, eg, MOSS.NEW.*

**Receiving model** is the drainage model to receive the SSD file from WALLRUS. This must be the model from which the SSD file was originally created.

**Redraw network** is used to redraw the network with the new information supplied by WALLRUS.

## Drainage analysis - MicroRAT

IGSEWAT.DAT, SEW043

<b>Drainage analysis</b>
<b>Data to MicroRAT</b>
<b>Data from MicroRAT</b>
<b>Invoke MicroRAT</b>

**Data to MicroRAT** creates an SSD file from the single network held in the drainage model.

**Data from MicroRAT** loads an SSD file created in Wallrus. Additional and modified information is incorporated into a rebuilt drainage model.

**Invoke MicroRAT** invokes the MicroRAT program. When you exit MicroRAT, you are returned to the 'Data from MicroRAT' menu.

## Data to MicroRAT

IGSEWAT.DAT, SEW043, SEW089

Drainage analysis	Data to MicroRAT
Data to MicroRAT	File name
Data from MicroRAT	Job title
Invoke MicroRAT	Output invert levels (T)
	Output pipe sizes (T)
	System control parameters

**File name** is the name of the sewer system data (SSD) file to be created for MicroRAT. If no file name is specified, MOSS.SSD is used.

◇ *Within MicroRAT the suffix .SSD must be explicitly specified because MicroRAT expects to use a .RSD file by default.*

**Job title** is the title written in the first record of the SSD file and is normally used to describe the scheme or project.

**Output invert levels** is a toggle to indicate whether invert levels are to be passed to WALLRUS (if they exist) or whether MicroRAT will calculate the invert levels itself.

**Output pipe sizes** is a toggle to indicate whether pipe sizes are to be passed to MicroRAT (if they exist) or whether MicroRAT will calculate the pipe sizes itself.

**System control parameters** allows parameter defaults to be changed. See the 'System control parameters - MicroRAT' menu for details.

◇ *All branches in the drainage model must be connected as one dendritic network before the SSD file is created.*

## System control parameters - MicroRAT

This menu is used to define global WALLRUS information to be contained in the .SSD file.

IGSEWAT.DAT, SEW044

System control parameters
UK/International format (T)
Global dry weather flow

**UK or International format** is a toggle to indicate whether data is passed to WALLRUS in UK or International format (ie, record types 4 or 18).

**Global dry weather flow** defines the dry weather flow in m<sup>3</sup>/s.

◇ *The values set in this menu may be passed to the MOSS Drainage File.*

## Data from MicroRAT

IGSEWAT.DAT, SEW043, SEW088

Drainage analysis	Data from MicroRAT
Data to MicroRAT	SSD filename
Data from MicroRAT	Receiving model
Invoke MicroRAT	Redraw network (T)

**SSD filename** is the name of the SSD file to be input to MOSS. If no file name is specified, MOSS.SSD is used.

- ◇ *A new sewer data file created by the Hydrograph method has the suffix .NEW. In this case, the file name must include the .NEW suffix, eg, MOSS.NEW.*

**Receiving model** is the drainage model to receive the SSD file from MicroRAT. This must be the model from which the SSD file was originally created.

**Redraw network** is used to redraw the network with the new information supplied by MicroRAT.

## MOSS Drainage Format

IGSEWAT.DAT, SEW002, SEW046

Drainage design	Drainage analysis to MOSS
Add/amend manhole	Data to MOSS Drainage Format from SSD
Add/amend branch	Data from MOSS Drainage Format MDF
Add/amend gully	Invoke external program
Construction defaults	
Area calculations	
Drainage analysis	MOSS to Drainage analysis
MOSS Drainage Format	Drainage analysis to MOSS
Drawing management	
Report network	
Copy drainage model	

**Data from SSD** processes an SSD file. This is the standard file format used by programs such as WALLRUS and contains hydraulic data only.

**Data to MOSS Drainage Format** creates an MDF file from the information held in the drainage model. The MDF file contains both hydraulic and construction data from the drainage model. This allows external programs to perform calculations using the data and the entire drainage network to be reconstructed if required.

**Data from MOSS Drainage FormatMDF** processes an MDF file. This is a generic file format containing both hydraulic and construction data.

◇ *For details of the MDF file data format, refer to the beginning of this chapter.*

**Invoke external program** invokes an external program via the procedure msexternal.com. When you exit the program, you are returned to the 'Data from MOSS Drainage Format' menu.

In order for your external program to be invoked when you select this field, you must edit the procedure msexternal.com so that it starts up your external program in the way you require.

For details of how to start your external program, refer to the documentation supplied.

## Data to MOSS Drainage Format

IGSEWAT.DAT, SEW046, SEW090

Drainage analysis	Data to MOSS Drai Format
Data to MOSS Drai Format	File name
Data from MOSS Drai Format	Job title
	System control parameters
	MOSS Drai Format level (T)
	Output header details (T)
	Output manhole details (T)
	Output network details (T)
	Output pipe details (T)
	Output gully details (T)

**File name** is the name of the MOSS Drainage file (MDF) to be created. If no file name is specified, MOSS.MDF is used.

**Job title** is the title written in the second record of the MDF file and is normally used to describe the scheme or project.

**System control parameters** allows parameter defaults to be changed. See the 'System control parameters' menu for details.

**MOSS Drainage Format level** is a toggle which determines the level of detail written out to the MDF file. Data in the file may be commented with descriptions from the comment file *mdfdes.dat* and compressed, depending upon the level selected.

- Level 1      Non-commented, compressed.  
No comments are added and only records with data items are written.
- Level 2      Fully commented, compressed  
Comments are added from the comment file and only records with data items are written.
- Level 3      Non-commented, uncompressed.  
No comments are added but all records are written, even those with blank data items.
- Level 4      Fully commented, uncompressed  
Comments are added from the comment file and all records are written, even those with blank data items.

**Output header details** is a toggle which determines whether system control parameter data is written to sections 100, 110 and 120 in the MDF.



**Output manhole details** is a toggle which determines whether manhole data is written to section 200 in the MDF.

**Output network details** is a toggle which determines whether network data is written to section 300 in the MDF.

**Output pipe details** is a toggle which determines whether pipe data is written to section 400 in the MDF.

**Output gully details** is a toggle which determines whether gully data is written to section 500 in the MDF.

- ◇ *For details of the MDF file data format, refer to 'MOSS Drainage File' at the beginning of this chapter.*

## Data from MOSS Drainage FormatSSD

IGSEWAT.DAT, SEW046, SEW0878

Drainage analysis to MOSS	MOSS Drainage FormatSSD
Data to MOSS Drainage FormatSSD	MOSS data SSD file name
Data from MOSS Drainage FormatMDF	Receiving model
	Redraw network (1)

**MOSS data Ffile name** is the name of the MOSS Drainage FormatSSD file to be input to MOSS. If no file name is specified, MOSS.MDFSSD is used.

- ◇ *A new sewer data file created by the Hydrograph method has the suffix .NEW. In this case, the file name must include the .NEW suffix, eg, MOSS.NEW.*

**Receiving model** is the drainage model to receive the SSD file from WALLRUS. This must be the model from which the SSD file was originally created.

**Redraw network** is used to redraw the network with the new information supplied by WALLRUS.

## Data from MDF

IGSEWAT.DAT, SEW046, SEW087

Drainage analysis to MOSSMOSS Drain	Data From MDF
Data from SSD	MOSS data file name
Data from MDF	Redraw network (T)

**MDF file name** is the name of the MDF to be input to DRAINAGE. If no file name is specified, MOSS.MDF is used.

**Redraw network** is a toggle which determines whether the network is redrawn with the new information from the MDF.

◇ *For details of the MDF file data format, refer to 'MOSS Drainage File' at the beginning of this chapter.*

## Drawing management

'Drawing management' sets up the drawing defaults to be used in DRAINAGE.

IGSEWAT.DAT, SEW002, SEW030

Drainage design	Drawing management
Add/amend manhole	Manhole colour (T)
Add/amend branch	Branch colour (T)
Add/amend gully	Gully colour (T)
Construction defaults	Draw pipe size (Y/N) (T)
Area calculations	Draw pipe grad (Y/N) (T)
Drainage analysis MOSS to Drainage analysis	Draw pipe arrows (Y/N) (T)
MOSS Drainage Format Drainage analysis MOSS	Draw brch/pipe no (Y/N) (T)
Drawing management	Draw pipe shape (Y/N) (T)
Report network	
Copy drainage model	

**Manhole colour** is the colour used to draw manholes.

**Branch colour** is the colour used to draw branches.

**Gully colour** is the colour used to draw gullies.

**Draw pipe size** indicates whether pipe sizes are included in the drawing.

**Draw pipe grad** indicates whether pipe gradients are included in the drawing.

**Draw pipe arrows** indicates whether pipe arrows are included in the drawing.

**Draw brch/pipe no** indicates whether branch/pipe numbers are included in the drawing.

**Draw pipe shape** indicates whether pipe shapes are included in the drawing.

- ◇ *'Drawing management' is the first menu to appear if you are modifying an existing drainage model.*
- ◇ *Select Proceed to redraw the network with the displayed default values and continue to the 'Drainage design' menu.*
- ◇ *Use major option DRAW to produce fully annotated drawings of the drainage model.*

## Report manholes

The report facilities give information from the drainage model about manholes, gullies and pipes.

## Report all manholes

IGSEWAT.DAT, SEW031, SEW048, SEW049

Report network	Report manholes	All manholes
Report manholes	All manholes	Hydraulic data (T)
Report branches	Selected manhole	Construction data (T)
Report gullies	Selected branch	

**Hydraulic data** is a toggle to indicate whether hydraulic data is reported.  
**Construction data** is a toggle to indicate whether construction data is reported.

## Report selected manhole

IGSEWAT.DAT, SEW031, SEW048, SEW050

Report network	Report manholes	Selected manhole
Report manholes	All manholes	Manhole label number
Report branches	Selected manhole	Hydraulic data (T)
Report gullies	Selected branch	Construction data (T)

**Manhole label and number** define the manhole to be reported.  
**Hydraulic data** is a toggle to indicate whether hydraulic data is reported.  
**Construction data** is a toggle to indicate whether construction data is reported.

## Report manholes on branch

IGSEWAT.DAT, SEW031, SEW048, SEW068

Report network	Report manholes	Manholes on branch
Report manholes	All manholes	Branch number
Report branches	Selected manhole	Hydraulic data (T)
Report gullies	Selected branch	Construction data (T)

**Branch number** defines the branch containing the manholes to be reported.  
**Hydraulic data** is a toggle to indicate whether hydraulic data is reported.  
**Construction data** is a toggle to indicate whether construction data is reported.

## Report branches

### Report all branches

IGSEWAT.DAT, SEW031, SEW051, SEW052

Report network	Report branches	All branches
Report manholes	All branches	Hydraulic data (T)
Report branches	Selected branch	Construction data (T)
Report gullies	Selected pipe	

**Hydraulic data** is a toggle to indicate whether hydraulic data is reported.  
**Construction data** is a toggle to indicate whether construction data is reported.

### Report selected branch

IGSEWAT.DAT, SEW031, SEW051, SEW053

Report network	Report branches	Selected branch
Report manholes	All branches	Branch number
Report branches	Selected branch	Hydraulic data (T)
Report gullies	Selected pipe	Construction data (T)

**Branch number** defines the branch to be reported.

**Hydraulic data** is a toggle to indicate whether hydraulic data is reported.

**Construction data** is a toggle to indicate whether construction data is reported.

## Report selected pipe

IGSEWAT.DAT, SEW031, SEW051, SEW054

Report network	Report branches	Selected pipe
Report manholes	All branches	Branch/pipe number
Report branches	Selected branch	Hydraulic data (T)
Report gullies	Selected pipe	Construction data (T)

**Branch/pipe number** defines the pipe to be reported.

**Hydraulic data** is a toggle to indicate whether hydraulic data is reported.

**Construction data** is a toggle to indicate whether construction data is reported.

- ◇ *A negative value for roughness indicates that Mannings coefficient  $1/n$  has been used.*



## Report gullies

### Report all gullies

IGSEWAT.DAT, SEW031, SEW055, SEW056

Report network	Report gully	All gullies
Report manholes	All gullies	Hydraulic data (T)
Report branches	Selected gully	Construction data (T)
Report gullies		

**Hydraulic data** is a toggle to indicate whether hydraulic data is reported.  
**Construction data** is a toggle to indicate whether construction data is reported.

### Report selected gully

IGSEWAT.DAT, SEW031, SEW055, SEW057

Report network	Report gully	Selected gully
Report manholes	All gullies	Gully label number
Report branches	Selected gully	Hydraulic data (T)
Report gullies		Construction data (T)

**Gully label and number** define the gully to be reported.

**Hydraulic data** is a toggle to indicate whether hydraulic data is reported.

**Construction data** is a toggle to indicate whether construction data is reported.

## Copy drainage model

'Copy drainage model' is used to copy a drainage network from one model to another.

IGSEWAT.DAT, SEW002, SEW058

Drainage design	Copy drainage model
Add/amend manhole	Existing drainage model
Add/amend branch	New drainage model
Add/amend gully	
Construction defaults	
Area calculations	
Drainage analysisMOSS to Drainage analysis	
MOSS Drainage FormatDrainage analysis to MOSS	
Drawing management	
Report network	
Copy drainage model	

**Existing drainage model** is the model to be copied.

**New drainage model** is the name of the new model.

◇ *Major option COPY cannot be used for copying drainage models.*

# DRAINAGE macros

## Macro LONGDRAI

Drainage long section drawings may be produced using the macro LONGDRAI. This draws one branch string, the associated manholes and a section string taken along the branch string.

Manholes may be annotated with label/number, cover level and invert level. Pipes may be annotated with branch/pipe number, diameter, shape, gradient, length and fall.

LONGDRAI is based upon the standard LONGDRAW macro and uses many of the same variables. As with LONGDRAW the default label for box 1 is "Proposed Levels" and the default label for box 2 is "Distance". LONGDRAI automatically creates a third box to contain pipe invert levels. You may define the position and label of the third box, but the data contained in the box is determined by the macro.

Macro LONGLINE may be used to superimpose additional long sections taken along the same branch string.

### Example

To draw a drainage long section of branch 1 taken through the proposed road surface and to plot the existing ground surface with level annotation in box 4.

```
SECTION,ROAD TRIA MODEL,DRAINAGE MODEL
SECTION,LONG SECTION MODEL
177,S001,TRIA,L001
999

SECTION,GROUND TRIA MODEL,DRAINAGE MODEL
SECTION,LONG SECTION MODEL
177,S001,TRIA,L002
999

DRAW,DRAINAGE MODEL,LONG SECTION MODEL
900,LONGDRAI
lb=S001,lr=L001,hs=1000,vs=200,lc=cyan,tc=cyan
900,ONGLINE
lb=L002,lr=L002,ln=4,hn=e
999
```

In the following      PV implies any positive value  
                                  CV implies any characters  
                                  PF implies parameter file default.

**Input data**

Sheet details

Code	Description	Alternatives	Default
FD	First drawing if there is overplotting or if SL or SW are to be specified or if no truncation is required	"	-
OD	Subsequent drawing if there is overplotting	"	-
TR	Truncation or no truncation (of sheet area)	NOTR	TRUN TRUN
SL	Sheet length	PV	120
SW	Sheet width	PV	68
FR	Draw a frame Do not draw a frame Put registration marks on sheet edge Draw frame around windows	FRAM NOFR REGR WIND	NOFR
ML	Left margin	PV	1.0
MB	Bottom margin	PV	1.0
MT	Top margin	PV	1.0
MR	Right margin	PV	1.0
PA	Paged or non-paged drawing	NOPA PAGE	NOPA

◇ *If SL is assigned but not SW an A size sheet is specified.  
If SW is assigned but not SL a B size sheet is specified.*

Drawing details

Code	Description	Alternatives	Default
XO	Offset to be added to the left of the leftmost point	PV	0.0
YO	Offset to be added to the lowest point	PV	0.0
AL	Absolute level datum	PV	-
LP	Box in which the level parameter is to be annotated	PV	1
LD	Box in which the distance parameter is to be annotated	PV	2
HP	Box description of the level parameter	C = chainage D = distance E = existing P = proposed L = level * = text coded at TP	P
IN	Interval for annotation Chainage interval for M strings Point sequence interval for general strings	PV  -n for every nth point	every point every point
TP	Box description if HP=*	CV	-
HD	Box description of the distance parameter	C = chainage D = distance	D

		E = existing	
		P = proposed	
		L = level	
		* = text coded	
		at TD	
TD	Box description if HD=*	CV	-
DLP	Box in which the invert level is to be annotated	PV	3
TLP	Box description for DLP	CV	Invert level
AM	Annotate manholes	000	"
AP	Annotate branch/pipes	000	"
HS	Horizontal scale	PV	
VS	Vertical scale	PV	
LC	String colour	CV	BLACK
DL	Dashed line indicator	" for dashed line	Solid
TC	Text colour	CV	BLACK

**Model details**

<b>Code</b>	<b>Description</b>	<b>Alternatives</b>	<b>Default</b>
LB	Drainage branch string to be drawn	CV	
LR	Section string to be drawn	CV	
XS YS	Start point on reference string (SPRD)	PV PV	First point
XE YE	End point on reference string (SPRD)	PV PV	Last point
LS	Length of section to be drawn per page	PV	-

- ◇ *FD and OD are normally used when producing composite drawings. The assignment FD=" indicates to the macro that this is the first drawing and OD=" indicates it is a subsequent drawing.*
- ◇ *The only essential variables which need to be assigned in the macro are HS, VS, LB and LR ie the horizontal and vertical scales, the string label being drawn and the reference string label.*

**Macro PLANDRAI**

This macro will produce a plan drawing of a drainage (DRAI) model including some standard- annotation.

The macro defaults will draw the entire network but you may opt to draw only branches, manholes or gullies.

For each of these network components there is a choice of annotation, either standard annotation supplied by the 828 option or a sample of the more detailed annotation given by 858/859. For example, to annotate manholes code MAN as DETA to give label/number only or code AM as " to give label/number, cover level and invert level.

**Example**

```
900, PLANDRAI
pa=nopa, tr=trun, mlc=cyan, plc=cyan, glc=blue, gan=anno,
an='', ap='', rs=S001, ba=S001
```

will draw the entire network with pipes and manholes in cyan and gullies in blue. All gullies will be annotated with label/number only. Pipes and manholes will be given more detailed annotation but only those that are a part of branch 1.

**Input**

**Sheet details**

Code	Description	Alternatives	Default
PA	Paging	NOPA PAGE	PAGE
TR	Truncation or no truncation (of sheet area)	NOTR TRUN	NOTR
SL	Sheet length	PV	
SW	Sheet width	PV	
FR	Draw a frame Do not draw a frame Draw frame around window Put registration marks on sheet edge	FRAM NOFR WIND REGR	FRAM
ML	Left margin		1.0
MB	Bottom margin		1.0
MT	Top margin		1.0
MR	Right margin		1.0

◇ *If SL is assigned but not SW an A size sheet is specified  
If SW is assigned but not SL a B size sheet is specified*

**Drawing details**

Code	Description	Alternatives	Default
XL	Relationship of model to drawing	PV	
YL	Coordinates of bottom left point and bearing of left hand side	PV	
BE		PV	
LC	String colour	CV	BLACK
TC	Text colour	CV	BLACK
GR	Grid with edge ticks Grid with crosses at intersection Full line grid Do not draw a grid	EDGE CROS FULL NOGR	NOGR
XG	X spacing of grid	PV	50
YG	Y spacing of grid	PV	50
SC	Scale	PV	500

**Drainage details**

Code	Description	Alternatives	Default
------	-------------	--------------	---------

CH	Character height for text	PV	0.10
M	Draw manholes (default). Code as 000 to omit manholes from drawing	000	"
MDI	Manhole drawing interpretation	DETA SYMB	"
MAN	Manhole annotation (label/number only)	ANNO	" no annotation
MSS	Manhole symbol size in drawing units. Only code if MDI is left blank	PV	"
MLC	Manhole symbol colour	CV	BLACK
MTC	Manhole text colour	CV	BLACK
P	Draw pipes (default). Code as 000 to omit branches/pipes from drawing	000	"
BD	Branches to be drawn. Code branch string label if you wish to draw one branch only	S 'PV' eg, S001	S. for all branches
PDI	Pipe drawing interpretation	"	DETA
PAN	Pipe annotation (branch/pipe number)	ANNO	" no annotation
PLC	Pipe line colour	CV	BLACK
PTC	Pipe text colour	CV	BLACK
G	Draw gullies (default). Code as 000 to omit gullies from drawing.	000	"
GDI	Gully drawing interpretation	DETA SYMB	"
GAN	Gully annotation (label/number only)	ANNO	"
GSS	Gully symbol size in drawing units. Only code if GDI is blank	PV	"
GLC	Gully symbol colour	CV	BLACK
GTC	Gully text colour	CV	BLACK
AM	More detailed pipe annotation (label/number, cover level and invert level)	"	000
AP	More detailed pipe annotation (branch/pipe number, diameter, shape, gradient, length and fall)	"	000
AG	More detailed gully annotation (label/number, cover level and outlet level)	"	000
RS	Reference branch string for detailed manhole annotation (only the default value is permitted at Version 9.0)	S 'PV'	" for all branches
BA	Branch string for more detailed pipe annotation	S 'PV'	S. for all branches

# Chapter 13 Customising MOSS

## Customising Moss

### Major option MACRO

#### Introduction

Major option MACRO allows you to define commonly used MOSS option combinations, drawing symbols and drawing lines as 'sets of data' known as macros. This chapter is in four sections -

##### 1. **Command macros**

A linemode facility which includes

- Minor option 900 Use a macro
- Minor option 901 Add macro to library
- Minor option 902 Delete macro from library
- Minor option 903 Report macro library list.

◇ *Minor option 900, 'Use a macro' is available in major option DRAW in graphics.*

##### 2. **Macrosymbols and macrolines for drawing**

A linemode facility which includes

- Minor option 906 Add a macrosymbol or macroline to the macrolibrary
- Minor option 907 Delete a macrosymbol or macroline from the macrolibrary
- Minor option 908 Print a macrolibrary list.

##### 3. **MACROSYMBOL**

A graphic facility complementary to the linemode facility Macrosymbols and macrolines for drawing.

In MACROSYMBOL all the power and ability of the minor options 906, 907 and 908 is available. However, in the graphic presentation no attempt has been made to relate to the linemode minor options.

The Macrolibrary is common to all macro types. Therefore -

A macrosymbol or macroline created in linemode can be modified using



interactive graphics, and vice versa.

#### 4. Major option UPM

This document provides only the information essential to a MOSS user who holds a UPM Run Time licence. For example it explains how to start a UPM.

Holders of UPM Development licences should read the Guide to Development, Management and Distribution of UPMs for further information.

## Command macros

When MOSS is in frequent use, certain groups of minor options occur again and again. These will relate to such functions as 'tailored' design of standard features, standard forms of reports or drawings. To avoid the need to re-enter these each time, the sets of data, which are called 'command macros' or macros for short, may be stored and recalled when required.

An example is in the production of drawings tailored to a house style employing differing types of interpretation and annotation for particular string types. Standard macros for this very purpose are supplied with the system and are described in major option DRAW. (See Chapter 3)

For example the data set:-

```
DRAW, SURVEY MODEL
803, 5=501250, 111145, 200
804, PLAN
821, FRAM
822, CROS, 5=10, 10
825
999
```

could be generated via the PLANDRAW macro by coding the following:-

```
DRAW, SURVEY MODEL
900, PLANDRAW
FR='FRAM', SC=200, XL=501250, YL=111145, XG=10, YG=10
999
```

This is automatically expanded by MOSS into the full data set and those variables specified are inserted to create sound minor option data which is then run. Chapter 3 defines the PLANDRAW macro and the variables which may be used.

Macros may be written which contain fixed components eg a standard width or crossfall. This is acceptable if the components are truly fixed. Generally speaking, however, it is better to develop macros with variable components but to use a facility which sets default values in the absence of supplied ones.

The following examples indicate the use of variables and defaults. They develop from straightforward minor option sets through to the use of macros.

The example below is of a highway scheme where a standard cross section is to be defined from which a series of alternatives based upon different master alignments may be developed. In order to generate the road model from the master alignment, a series of DESIGN minor options are required as indicated below:-

```
DESIGN, ALIGNMENTS, ROAD MODEL
    GENERATE FULL ROAD CROSS SECTION FROM MASTER
    ALIGNMENT
    (DUAL TWO LANE WITH CENTRAL RESERVATION AND
    VERGES)
100, MAST, , LCRS, 0.0, 0.0, , -1.0, 1000.0
110, MAST, LCRS, LICH, -0.1, 0.0, , -0.01, 1000.0
100, MAST, LICH, LOCH, 0.0, 0.0, , -7.30, 1000.0
133, MAST, , LOCH, 50.0, 0.0, , , 1000.0
100, MAST, LOCH, LVRG, -0.025, 0.0, , -1.0, 1000.0
100, MAST, , RCRS, 0.0, 0.0, , 1.0, 1000.0
110, MAST, RCRS, RICH, -0.1, 0.0, , 0.01, 1000.0
100, MAST, RICH, ROCH, 0.0, 0.0, , 7.30, 1000.0
133, MAST, , ROCH, 50.0, 0.0, , , 1000.0
100, MAST, ROCH, RVRG, -0.025, 0.0, , 1.0, 1000.0
999
```

Rather than repeating this data each time an offset or crossfall changes along the length of the scheme the minor options could be stored within a command macro and by considering some values as variable items added flexibility is provided. Whilst every item could be made variable, it would prove cumbersome to require that at run-time all values be always assigned. This situation is overcome by the use of default values which are the most common value of a particular item and these are stored with the command macro. When using a macro which contains default values it is not necessary to define the value of such items unless it is required to override them with a new value.

To represent the above data in a stored macro would require the following instruction with default values assigned. Offset and crossfall have not been assigned as variables and therefore cannot be easily changed.

```
MACRO
901, STDXSECT
JOE BLOGGS.....STANDARD ROAD SECTION
DEFAULT
LCROFF=-1.0, RCROFF=1.0, LCWOFF=-7.3, RCWOFF=7.3,
LVROFF=-1.0, RVROFF=1.0, DESSPEED=50.0, KERBHT=-0.1
OPTION
100, MAST, , LCRS, 0.0, ST, , LCROFF, FN
110, MAST, LCRS, LICH, KERBHT, ST, , 0.01, FN
100, MAST, LICH, LOCH, 0.0, ST, , LCWOFF, FN
133, MAST, , LOCH, DESSPEED, ST, , , FN
```

```
100,MAST,LOCH,LVRG,0.025,ST,,LVROFF, FN
etc
```

To use such a macro with all the default values would require the following:-  
(Note that ST and FN, the start and end chainages must be defined.)

```
DESIGN, ALIGNMENTS, ROAD MODEL 4
900,STDXSECT
ST=0.0, FN=750.0
999
```

To override the carriageway width to 8.0 would require:-

```
DESIGN, ALIGNMENTS, ROAD MODEL 5
900,STDXSECT
ST=0.0, FN=750.0, LCWOFF=-8.0, RCWOFF=8.0
999
```

The previous examples assume that the options forming a macro are all in the standard MOSS minor option format, and this is the assumption made by the system. However there are occasions where non standard formats are required and these can be defined to the system and stored with the macro. In programming terms the macro processor is creating input records in character form which are then processed by the MOSS system as if they were normal input records.

A further feature is provided, the arithmetic feature, which gives further flexibility. When a macro is created each option line consists of both constant items and variable items, the variable items have values assigned to variable name, one of the arithmetic operators + - / \* (plus, minus, divide, multiply) and a numeric constant. Possible uses of this feature are to change the sign of a variable eg.

VARIAB or VARIAB\*-1.0

When the arithmetic feature is used it is necessary to define the accuracy of the result using the FORMAT sub option.

This facility can be used to simplify the road cross section even further, the central reserve, carriageway and verge offset on the left and right of the section differ only in their signs and the macro can be simplified as follows.

```
MACRO
901,STDXSECT
T.A.R.MACADAM...STANDARD ROAD CROSS SECTION
DEFAULT
CRWID=1.0, CWWID, =7.3, VRWID=1.0, DESSPEED=50.0,
KERBHT=-0.1
OPTION
100,MAST,,LCRS,0.0,ST,,CRWID*-1.0, FN
110,MAST,LCRS,LICH,KERBHT,ST,0.01, FN
100,MAST,LICH,LOCH,0.0,ST,,CWWID*-1.0, FN
133,MAST,,LOCH,DESSPEED,ST,,, FN
100,MAST,LOCH,LVRG,-0.025,ST,VRID*-1.0, FN
100,MAST,,RCRS,0.0,ST,,CRWID, FN
etc
```

The arithmetic feature may also be used to change the units of an item of data. As an example, the minor option 021 only allows bearings to be input in radians, the creation of a macro would allow the bearings to be input in degrees or grads and then converted into radians using the arithmetic feature.

```
MACRO
901,GRADS021
ANGLES OGILVY...INPUT OPTION 002
FORMAT
I3,3A4,F8.3,2F10.3,F8.3,2F10.3,F8.3
OPTION
021,,,LABEL,,,POINT,,5.0,B/63.6619772
END
```

The input would be

```
EDIT,MODEL
900,GRADS021
LABEL=STRN,POINT=5,B=399
```

The advantage of using macros is that once created they reduce the amount of data to be specified by the user as repeated data only be coded once. The creation of a set of macros can considerably increase the power of the MOSS option approach.

Further uses of the macros can be considered, firstly they can be used as a means of standardising on aspects of design or drawing office practice. Secondly they can be used where the specification of standard MOSS options is cumbersome. For instance to change a point in an existing master alignment requires the specification of four minor options, this can be reduced by the creation of a macro as follows.

```
MACRO
901,MASTER
AUTHORS NAME...CHANGE A POINT IN A MASTER ALIGNMENT
OPTION
022,,,LAB,,,POINT,,X,Y,Z
021,,,LAB,,,POINT,,4,CH
021,,,LAB,,,POINT,,5,BEAR
021,,,LAB,,,POINT,,6,RAD
END
```

to use the macro

```
EDIT,MODEL
900,MASTER
X=123456.123,Y=234567.890,Z=38.2,CH=351.678,BEAR=1.21234
, RAD=-999999.9,LAB=M001,POINT=5
999
```

Macros are stored in the macro library and minor options are provided to allow macros to be added to the library, deleted from the library and the contents of the library to be reported.

## Major options

The major options listed below can be used in conjunction with Major option MACRO.

ASSIGN  
OVERWRITE

## Minor options

900	Use a Macro
901	Add a Macro to the library
902	Delete a Macro from the library
903	Print a report of the contents of the macro library

## Data preparation

Major option MACRO

## Minor option 900 Use a macro

When a command macro is to be used the MOSS system constructs records in the format prescribed in the macro. This format will normally be the MOSS minor option format. The records are formed from the options comprising the macro and from variable data supplied. If any variable does not have a value assigned the default value stored within the macro will be used instead. Arithmetic prescribed within the macro is calculated. The resultant MOSS minor options are executed in the normal way.

## Input

Record 1

[Minor option 900](#)

Fields 1 - 2 Command macro name

Record 2

Values to be assigned to variables within the macro. These are coded:

'name = value'

eg A = 3.0

Each assignment is separated from the next by a comma and as many records as are necessary may be used. Each record must terminate with a comma except the last which must end with a blank. There must be no blanks between successive assignments.

If an assignment is to be made to a character variable and the value contains embedded blanks then the value must be surrounded by quotes, for example

A = 'AB D '.

- ◇ *If there are no values to be assigned, ie all the default values are to be taken or there are no variables within the macro, record type 2 must contain a single \* in column 1.*

- ◇ *When a user invokes a macro via the 900 option, there is a limit of 400 characters placed on the assigned values including separating commas eg SC=500,XL=123,YL=456.89 consumes 23 characters.*

## Output

In order to differentiate input data derived from macros from standard input data the record containing the values to be assigned (record type 2 above) will be marked with the text 'MACRO INPUT' and the minor options records resulting from the expansion of the macro will be marked with 'M'.

## Minor option 901 Add macro to library

The data needed to define a macro are the name and description of the function of the macro, the minor options comprising the macro, the format of the options data and the default values to be assigned to variable items within the data.

## Input

### Record 1

#### Minor option 901

Fields 1 - 2 Macroname consisting of up to 8 alphanumeric characters.

### Record 2

Cols 1 - 16 Author's name

Cols 17 - 80 Description of the function of the macro

### Record 3 Default Values

Cols 1 - 7 DEFAULT

Record 3a Defines the default values to be assigned to the variable names on the option records. These are coded in the form, 'name = constant default value'.

eg A=3.0,LABEL=ABCD

It is advisable to omit from the DEFAULT list any variables which must be set so that offending data may be easily identified in the output.

Variable names have a maximum of 8 characters and the default value should be no longer than the field that is to receive it. There is a limit of 400 characters which includes separating commas. The above example consumes 16 characters.

Each assignment of a default value is separated by a comma. Several records may be used but each must end with a comma except the last record which must end with a blank.

If no default values are required record types 3 and 3a may be omitted.

Where default values are assigned to character fields, if the value contains embedded blanks it must be surrounded by quotes.

eg A = 'STRING WITH BLANKS'

**Record 4    Format Description**

Cols 1 - 6    FORMAT

Record 4a    Defines the length and type of each field appearing on subsequent option records. If the arithmetic feature is used it is also necessary to define the number of decimal places required in the resultant number.

The following types of fields are permitted

I            Integer

F            Fixed length real number

A            Characters

X            Spaces

The length of the field follows the type and is itself followed by a decimal point and the number of decimal places if the arithmetic feature is being used on a real field.

I8            Stands for an Integer field of 8 columns.

F6            Stands for a fixed length real field of 6 columns.

F6.3         Stands for a fixed length real field of 6 columns in which arithmetic operations are to be carried out and the result expressed to 3 decimal places.

A5            Stands for a character field of 5 columns.

A80          Stands for a character field of 80 columns, eg a complete record. This is the most convenient and should be used unless the arithmetic feature is required.

Where several consecutive fields are of the same type and length a count digit may be placed in front of a field description, eg

3I8          Stands for three consecutive integer fields of 8 columns.

Field descriptions are coded in the same order as the constants and variable names specified on the OPTION cards. Descriptions are separated by commas and several records may be used, but each must end with a comma except the last which must end with a blank.

Note that if the standard MOSS minor option layout is to be used it is not necessary to specify any format information as

the default format I3,3A4,F8.3,2F10.3,F8.3,2F10.3,F8.3 will be used.

If a MACRO consists of several records of different formats it is necessary to state the format required. If a return to the default format is required it must be coded explicitly.

A special facility exists to consider the whole of an input record as a character string and it is possible to make parts of the string variable by specifying a name enclosed in ampersands eg

THIS IS A STRING CALLED &NAME& STRING

If this appeared in a macro : on execution &NAME& would be replaced by whatever had been assigned to it, irrespective of length. This if the value of NAME was to be G, the resultant characters would be

THIS IS A STRING CALLED G STRING

- ◇ *This facility is useful for standardising on such things as headings, allowing only part to vary. Note that such a field must be the only field on an input record and the format would be A80. The field may contain several variable names enclosed in &s.*

**Record 5    Input records comprising the macro.**

Cols 1 - 6    OPTION

Record 5a    Defines the input records comprising the macro.

Each record will consist of a series of fields separated by commas. Each field will either be defined by a numerical constant or variable name. Where a field on the input is not required code two consecutive commas. Several records may be used to define one input record but each must terminate with a comma and the last must terminate with a blank. No embedded blanks are allowed. Note that the minor option 999 may not be included in a macro.

Note that the variable names may consist of up to 8 characters and that the names OPTION, DEFAULT, FORMAT, END may not be used for variables.

When inserting variable data into part of an alphanumeric field the variable name must be surrounded by ampersands, eg &VARIAB&. See under record type 4a for a complete discussion of this feature.

To use the arithmetic feature a variable name may be followed by one of the operators + - \* / (add, subtract, multiply, divide) and a numeric constant. It may only be used within minor option formats and only for REAL or INTEGER variables eg SUM\*2.0.

In this example, on execution of the macro the result of this calculation will reside in the field. Note that if the result of the



computation is a real number special conditions apply to the FORMAT specification.

A variable may not be assigned negative simply by coding -VARI. The method used is to code VARI\*-1.0. Alternatively the value may be set negative within DEFAULT.

For formats other than A80, the 'field=' method (eg 3=LABL,7=90.0) may not be used.

Where it is necessary to change the format code records 4 and 4a again followed by records 5 and 5a.

**Record 6**

Cols 1 - 3    END

**Example**

**Typical input**

```

MACR
902,SURVDRAW
901,SURVDRAW                                record 1
M.S.L.DRAWING USING STANDARD SURVEY DETAILS AT 1/500      record 2
DEFAULT                                                record 3
PA=PAGE,TR=" ,SL=" ,SW=" ,FR=" ,ML=1,MB=1,MT=1,MR=1,XL=" ,YL=" ,
BE=" ,LC=" ,TC=" ,GR=" ,XG=50,YG=50,SC=500,IO=" ,BD=" ,XB=" ,YB   "=",
YB=" ,XT=" ,YT=" ,LE=000,AN=0,PD=000,OD=000
FORMAT                                                record 4
A80                                                    record 4a
OPTION                                                record 5
&PD&800, , , 1, &SL&, &SW&                            record 5a
&OD&801,OVER                                          record 5a
802, , , , &ML&, &MB&, , &MR&, &MT&                    record 5a
803,PLAN, &PA&, &TR&, &BE&, &XL&, &YL&, &SC&          record 5a
804,PLAN, &IO&, &BD&, , &XB&, &YB&, , &XT&, &YT&      record 5a
821, &FR&                                             record 5a
822, &GR&, , , , &XG&, &YG&                            record 5a
805, &LC&                                             record 5a
806, &TC&                                             record 5a
810,MACR,TADP,OLE, , -2                               record 5a
826,TP
...
810
830
019
019,*, , , -1.0
019,TP, , , -1.0
019,REC, , , -1.0
019,CIR, , , -1.0
019, , , , 1
825, ,DETA
861,PMHS,SQUA,REMH,0.465, , , 0.15, , , 0.0
861,PMHR,ROUN,DMHL,0.465, , , 0.15, , , 0.0

```

```

...
861,PTR3,TREE,SYMB,2.0,,,2.0,,,0.0
&LE&686,L,,,3,,,0.2,,,45
019
019,PMHS,,, -1
019,PMHR,,, -1
...
019,PTR3,,, -1
019,PMHR,,, -1
...
019,PTR3,,, -1
...
019,P,,,1
019,,, -1
019,,, -1
825,,DETA
END
999

```

record 5a  
record 5a  
record 5a  
record 6

Where a macro allows more than one combination of minor options, for example FD and OD above. It is possible to switch between the alternatives by inserting a variable before the minor option. The variable may be set to equal “ to include the option or 000 to exclude it.

- ◇ *This technique is possible only where an A80 format is used.*
- ◇ *When formats other than A80 are used, you may employ the following technique. Exchange the minor option for a variable eg:*

*800,,,,1,SL,SW becomes FD,,,,1,SL,SW,*

*It is then possible to set the variable to the minor option number to include the line, use a default FD = 000 to exclude it, or vice versa.*

## Minor option 902 Delete macro from library

### Input

Minor option 902

Field 1 - 2 Name of macro to be deleted.

### Example

902 , LAYB

This deletes a macro called ‘LAYB’

- ◇ *When perfecting macros, users may encounter difficulties due to the macro file becoming full. This problem may be avoided by using the following technique:-*

```

MOSS
MACRO
    delete old version of macro
902,MACRONAME
999
    remove space from macro file
COMPRESS,MACROFILE
MACRO
    add new version of macro
901,MACRONAME
.
.
999
    
```

## Minor option 903 Report macro

Print a report of the names and descriptions of all the command macros in the library or list a complete macro, or list the complete macro file in detail. Optionally the macros as stored may be output in GENIO format in the style necessary for creating them.

### Input

#### Minor option 903

**Field 1 & 2** Macroname. If this is coded a complete listing is printed of the command macro. If this field is left blank a list of the names and descriptions of all the command macros in the library is produced.  
Code ALL to produce a complete listing of the macrofile.

**Field 3** Code FILE to produce an output file of the macro in input format. The output file name is read from the switch file (default MACRO.CRD).

### Output

```

9031BEM
LISTING OF MACRO `IBEM

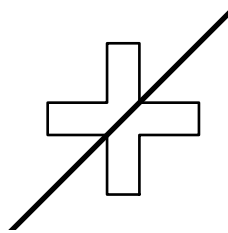
I.K.BRUNEL  GENERATE 12 STRINGS REPRESENTING AN I SECT BEAM FROM AXIS OF SYM
FORMAT
13,3A4,F.8.3,2F10,F8.3,2F10,F8
OPTION
110,AXOS,,LAB,H3,START,,W1*-1.0,END
110,AXOS,,LAB,H3,START,,W1,END
110,AXOS,,LAB,H2,START,,W1,END
110,AXOS,,LAB,H2,START,,W1,END
110,AXOS,,LAB,H1,START,,W2,END
110,AXOS,,LAB,H1*-1.0,START,,W2,END
110,AXOS,,LAB,H2*-1.0,START,,W1,END
110,AXOS,,LAB,H3*-1.0,START,,W1*-1.0,END
110,AXOS,,LAB,H2*-1.0,START,,W1*-1.0,END
110,AXOS,,LAB,H1*-1.0,START,W2*-1.0,END
110,AXOS,,LAB,H1,START,W2*-1.0,END
110,AXOS,,LAB,H2,START,W1*-1.0,END
END
    
```

## Macrosymbols and macrolines for drawing

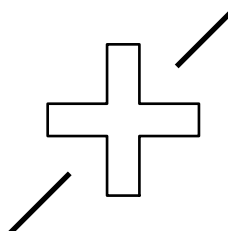
To extend the power of the MOSS plotting options it is possible to define 'macrosymbols' and 'macrolines' which are sets of lines defining a desired shape to be drawn.

When drawing detailed plans and symbolic interpretation of detail strings is required, point strings are deciphered according to their string label and standard symbols plotted at each point on the string. Other strings, such as hedges, verges, and fences are plotted with standard line types. It is however desirable that symbols and line types can be user defined as it is impractical to provide standard facilities for everything likely to be encountered. The macrosymbol facility allows the user to define his own symbols to be plotted at each point on a string: the macroline facility allows the user complete flexibility in defining linestyles constructed of one or more individual lines which when repeated along the length of a string give the desired result.

To comply with international drawing standards it is necessary to prevent drawing information becoming degraded by overplotting. This is demonstrated with cadastral symbols. For example:

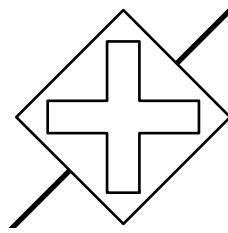


must be drawn as:



To achieve this macrosymbol drawing has been extended to permit definition of clip polygons. A clip polygon erases any element information which lies inside its boundary if the clip status of the element is erasable. Clip polygons are defined by impermeable lines created as part of the macrosymbol using pen code 4 or 5. Pen code 4 means the line is both drawn and impermeable. Pen code 5 means the line is not drawn but is impermeable.

In the following drawing:



the dashed line shows the impermeable boundary defined as part of the macrosymbol.

Note that the macrosymbol facility will plot symbols only: if a dashed line, solid line or macroline is also required through the points on the string, the string must be replotted.

Both macrosymbols and macrolines are defined simply by giving distance along and offset from a straight line. For each point so defined it is necessary to define the position of the drawing pen, whether up or down, when moving to the point. A maximum number of 5000 such points may be given. To create macrolines and macrosymbols the symbol should be drawn on squared paper to a convenient scale and the data derived from it.

Note that when a macrosymbol is drawn the point 0,0 on the macrosymbol corresponds to the point on the string. For a macroline the point 0,0 corresponds to the first point on the string. Any space between  $X=0$  and the leftmost  $X$  coordinate of the macro is deemed to be part of the macro.

Scaling of macrolines and symbols is achieved at the time of use by giving the required height and width of the symbol: thus it is possible to distort the symbol from its original shape.

The creation and use of macrolines and macrosymbols is extremely simple and they can be permanently stored in the macrolibrary. Minor options are provided to allow macrolines and macrosymbols to be added to and deleted from the library and the contents of the library to be printed out.

The use of macrolines and macrosymbols is described under major option DRAW.

### Minor options

- |     |   |
|-----|---|
| 906 | Add a macroline or macrosymbol to the library.  |
| 907 | Delete a macroline or macrosymbol from the library.   |
| 908 | Print a report of all the names and descriptions of all the macrosymbols and macrolines in the library or list a complete macrosymbol or macroline. |

### Input

Code the major option MACRO.

## Minor option 906 Add macrosymbol/macroline to library

The data needed to define a macrosymbol or macroline are its name and description and a set of coordinates and pen status indicators.

**Input****Record 1 - Minor option**

Minor option 906

Field 1 & 2 Name of the macrosymbol or macroline.

Field 3 Code SYMB if a macrosymbol or LINE if a macroline.

◇ *If field 3 is set to LINE pen status 4 and 5 are invalid.*

**Record 2 - Title**

Cols 1 - 16 Author's name

Cols 17 - 80 Description of the macrosymbol or line

Note that this must be coded in fixed format

**Record 3 - Macro parameters**

Cols 24 - 33 Distance along baseline to point. (Length)

Cols 34 - 43 Offset from baseline to point. (Height)

These fields must be coded with no decimal point and must be in the range -99 to +99.

Cols 44 - 51 Pen status

- 1 define a reference point for use in major option DRAW.
- 2 if the pen is down when moving to this point (permeable line).
- 3 if the pen is up when moving to this point (permeable line).
- 4 if the pen is down when moving to this point (impermeable line).
- 5 if the pen is up when moving to this point (impermeable line).

**Record 4 - Terminator**

This record is required to terminate a macrosymbol or macroline or to terminate a single line within a multiline macroline.

This record must be coded in fixed format.

Cols 32 - 33,

42 - 43, Code 1

50 - 51

Up to 5000 points are allowed in a macrosymbol or macroline

When specifying a macroline the first record type three must be an initiating coordinate and is used when the macroline is first entered. Repetition occurs from the second point only. For macrosymbols the first coordinate is used for each symbol.

**Record 5**

Cols. 1 - 3 End

Example 1

Macroline - Hedge

The following example shows the data necessary to create a macroline representing a hedgerow.

```

ADD A MACROLINE TO THE MACRO LIBRARY
906, HEDGEROWLINE
CAPABILITY BROWN SYMBOLIC REPRESENTATION OF A HEDGEROW (MULTIPLE LINE)
      0      2      3
      2      4      2
     10      4      2
     12      2      2
     14      4      2
     22      4      2
     24      2      2
     26      4      2
     34      4      2
     36      2      2
    -1     -1     -1
      0      0      3
     30      0      2
     32      0      3
     34      0      2
     36      0      3
    -1     -1     -1
      0     -4      3
      4     -4      2
      6     -2      2
      8     -4      2
     16     -4      2
     18     -2      2
     20     -4      2
     28     -4      2
     30     -2      2
     32     -4      2
     36     -4      2
    -1     -1     -1
*END
  
```

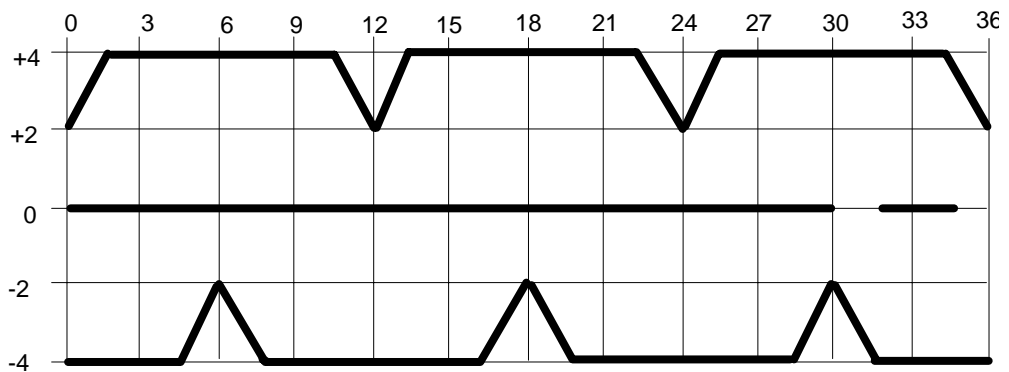


Figure 13 - 1 Example macroline - Hedge

- ◇ *The grid shown in Figure 13 - 1 is proportional only. Scaling of macrosymbols and macro lines is achieved at the time of use by giving the required height and width of the symbol; thus it is possible to distort the symbol from its original shape.*
- ◇ *Macrolines must extend along positive X axis.*
- ◇ *This macroline contains multiple elements, each element is terminated by a -1 -1 -1 line. In a macroline multiple elements ensure that; where a macroline is to be clipped to a drawing frame each element is drawn to the point of clipping.*

Example 2

Macrosymbol - Church

This example shows the data necessary to create a macrosymbol representing a church.

```

ADD A MACROSYMBOL TO THE MACRO LIBRARY
906, CHURCH, SYMB
J  VICAR      SYMBOLIC REPRESENTATION OF A CHURCH
                0      0      3
                2      0      2
                2     -4      2
               -2     -4      2
               -2      0      2
                0      0      2
               -1     -1     -1
                0      6      3
                0      6      2
                0      0      3
                2      4      3
               -2      4      2
               -1     -1     -1
*END
    
```

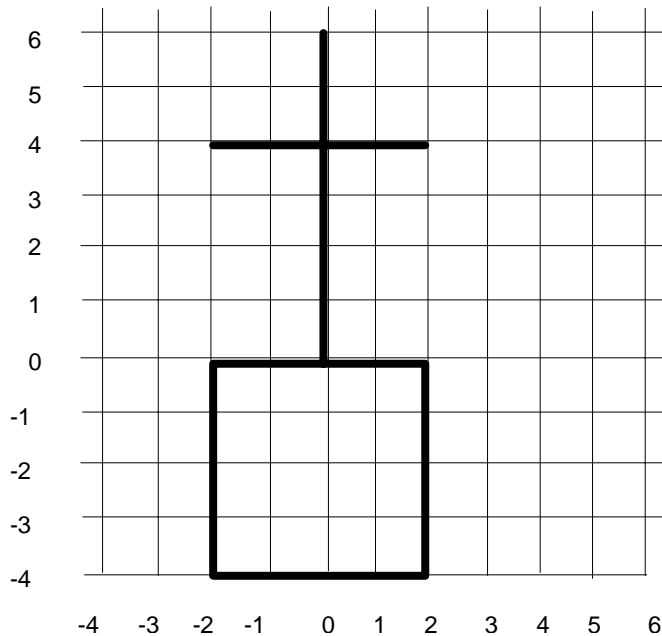


Figure 13 - 2 Example macrosymbol - Church

- ◇ *The grid shown in Figure 13 - 2 is proportional only. Scaling of macrosymbols and macro lines is achieved at the time of use by giving the required height and width of the symbol; thus it is possible to distort the symbol from its original shape.*
- ◇ *This macrosymbol contains multiple elements, each is terminated by a - 1 -1 -1 line. In a macrosymbol multiple elements ensure that; should area fill or hatching of the symbol be required, fill or hatch will apply to individual elements. Hatching within a macrosymbol is only available using major option ENHANCE.*



Example 3

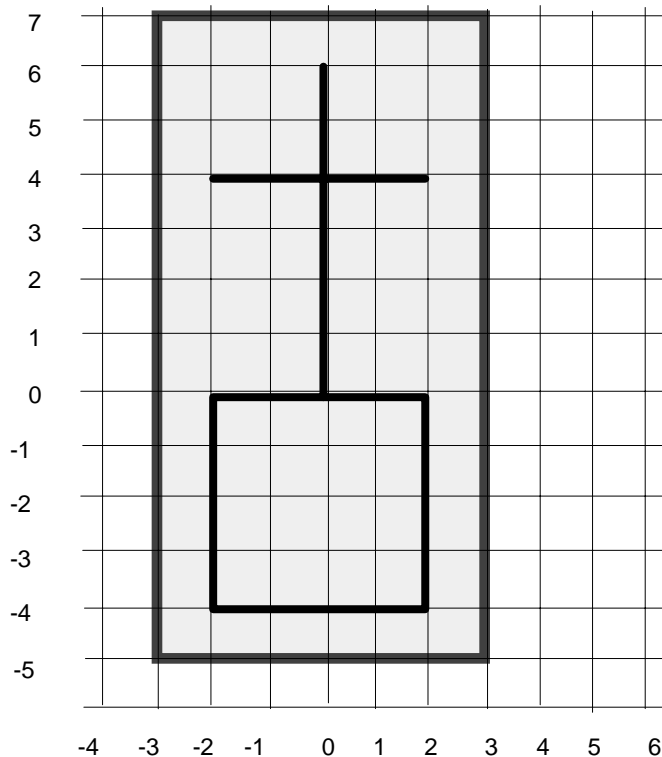
Macrosymbol - Church (with impermeable clip polygon)

This example shows the data necessary to create a macrosymbol representing a church.

```

ADD A MACROSYMBOL TO THE MACRO LIBRARY
906, CHURCH, SYMB
J  VICAR      SYMBOLIC REPRESENTATION OF A CHURCH
                0      0      0
                2      0      2
                2     -4      2
                -2     -4      2
                -2      0      2
                0      0      2
                -1     -1     -1
                0      6      3
                0      0      2
                2      4      3
                -2      4      2
                -1     -1     -1
                3      7      3
                3     -5      5
                -3     -5      5
                -3      7      5
                3      7      5
                -1     -1-1    0  0  1
0  0  3
2  0  2
2 -4  2
-2 -4  2
-2  0  2
0  0  2
-1 -1 -1
0  6  3
0  6  2
0  0  3
2  4  3
-2  4  2
-1 -1 -1
0  0  2
-1 -1 -1
-3  7  5
-1 -1 -1
3  7  4
3 -5  4
-3 -5  4
-3  7  4
-1 -1 -1
*END
*END

```



**Figure 13 - 3 Example macrosymbol - Church  
(with impermeable clip polygon)**

- ◇ *The grid shown in Figure 13 - 3 is proportional only. Scaling of macrosymbols and macro lines is achieved at the time of use by giving the required height and width of the symbol; thus it is possible to distort the symbol from its original shape.*
- ◇ *This macrosymbol contains multiple elements, each is terminated by a - 1 -1 -1 line. In a macrosymbol multiple elements ensure that; should area fill or hatching of the symbol be required, fill or hatch will apply to individual elements. Hatching within a macrosymbol is only available using major option ENHANCE.*

## Minor option 907 Delete macrosymbol/macroline from library

### Input

Minor option 907

Field 1 & 2 Name of the macrosymbol or macroline.

## Minor option 908 Report macrosymbols/macrolines

Print a report of the names and descriptions of all the macrosymbols and macrolines in the macrolibrary or list a single macroline or symbol or the complete library. Optionally the macros as stored may be output in GENIO format in the style necessary for creating them.

### Input

Minor option 908

Field 1 & 2 Name of the macrosymbol or macroline to be printed. If this field is omitted a list of names and descriptions is produced. If ALL is coded in field 1 the complete file will be listed.

Field 3 Code FILE to produce an output file of the macro in input format.

The output file name is read from the switch file (default MACRO.CRD)

### Output

Full report of names and descriptions.

```

908
LISTING OF THE MACRO FILE -----

-MACRO-- TYPE -----AUTHOR----- DESCRIPTION-----
HEDGE   LINE M.S.L.          HEDGE LINE FOR STANDARD DETAIL
MOSSYMB SYMB M.S.L.        MOSS SYMBOL
TADPOLE LINE M.S.L.        NEW TADPOLE SYMBOLIC REPRESENTATION OF AN INTERFACE
RETWALLR LINE M.S.L.       RETAINING WALL (RIGHT) S.S.S.
```

RETWALL LINE M.S.L. RETAINING WALL (LEFT) S.S.S.  
 BUILDNGR LINE M.S.L. SOLID SIDED BUILDING (RIGHT) S.S.S.  
 BUILDNGL LINE M.S.L. SOLID SIDED BUILDING (LEFT) S.S.S.  
 SECFCNCE LINE M.S.L. SECURE FENCES S.S.S.  
 LOWWALLR LINE M.S.L. WALL HEIGHT 0.1M-0.5M (RIGHT) S.S.S.  
 LOWWALLL LINE M.S.L. WALL HEIGHT 0.1M-0.5M (LEFT) S.S.S.  
 PROMCONT LINE M.S.L. PROMINENT CONTOUR S.S.S.  
 OPNBLDGR LINE M.S.L. OPEN SIDED BUILDING (RIGHT) S.S.S.  
 OPNBLDGL LINE M.S.L. OPEN SIDED BUILDING (LEFT) S.S.S.

### Report of a single macroline.

908ROADPATH  
 LISTING OF PLOT MACRO 'ROADPATH'

AUTHOR		DESCRIPTION															
JANE	DAY	ROAD			USED AS			PUBLIC			PATH			(O. S. SYMBOL)			
X	Y	PEN	X	Y	PEN	X	Y	PEN	X	Y	PEN	X	Y	PEN	X	Y	PEN
0	0	3	2	0	2	1	0	3	1	1	2	4	0	3			
6	0	2	5	0	3	5	-1	2	81	0	3	10	0	2			
9	0	3	9	0	2	12	0	3	14	0	2	13	0	3			
13	-1	2	16	0	3	18	0	2	17	0	3	17	1	3			
20	0	3	22	0	2	21	0	3	21	-1	2	24	0	3			
26	0	2	25	0	3	25	1	2	28	0	3	30	0	2			
29	0	3	29	0	2	32	0	3	34	0	2	33	0	3			
33	-1	2	36	0	3	38	0	2	37	0	3	37	-1	2			
-1	-1																

# Major option MACROSYMBOL

Major option MACROSYMBOL is only available in interactive graphics.

It enables you:

- to create new macrosymbols and lines, to store subsequently on the macrofile
- to modify existing macrosymbols and lines already stored on the macro file.

You draw or modify the macrosymbol shape you want by selecting points and defining lines or arcs.

Macrosymbols and macrolines can also be created and manipulated in Linemode using MACRO minor options 906, 907 and 908.

- ◇ *Scaling of macrosymbols and lines is achieved at the time of use by giving the required height and width of the symbol; thus it is possible to distort the symbol from its original shape.*

## Access to MACROSYMBOLS

IGENLT.DAT, GEN005

Drawing Options
DRAW Working Drawings
DRAW Contract Drawings
ENHANCE Drawings
Add annotation
CLIP drawings
LAYOUT
Drawing sheets
<b>MACROSYMBOLS</b>
Create/amend/store
VIEW
Perspective/Photo
VISUALISE
Prepare EPIC data
2DDXF
DPF conversion to DXF
NEW DPF Select DPF
NEW RPF Select RPF
REPORT
Models/strings/points

When you select **Macrosymbols**, the static menu and the dynamic menu display new menu boxes, and the scrolling menu area displays the Macro selection menu.

## Macro selection

The scrolling menu showing the macro selection menu consists of just one item: **Macro name**.

IGMACRT.DAT, MAC001

Macro selection
Macro name

The selection method menu shows:

SCREEN	LIST DPF	LIST MACRO	MASK
--------	-------------	---------------	------

You select the macrosymbol name as you select model names in other options - in other words, depending upon the circumstances, as follows.

If you want to **create a new macrosymbol**: from the static menu, select KEYB to activate the keyboard, and then type in the name of the new macrosymbol, which appears in the keyboard area as you type. Then select Proceed. The scrolling menu displays the Macro details menu.

If you want to **modify an existing macrosymbol** which is currently displayed in the graphics area: select it with the cursor. The name of the macrosymbol is displayed in the scrolling menu in the Macro name box. Select Proceed. The scrolling menu displays the Macro details menu.

(There is a proviso: selection from the graphics area doesn't apply to macrosymbols that are filled silhouettes rather than line drawings. The remedy is either to cancel the 'filling' first, or to use the selection method documented next.)

If you want to **modify an existing macrosymbol** which is not currently displayed in the graphics area but whose name you know: select KEYB as above, type in the name, and select Proceed. The scrolling menu displays the Macro details menu.

If you want to **modify an existing macrosymbol** which is not displayed in the graphics area and whose name you don't know or can't remember: Select LIST MACRO from the selection method menu. This lists in the scrolling menu the macrosymbols currently in the macro file. From these you select the one you want to change. Then select Proceed. The scrolling menu displays the Macro details menu.

Only one macrosymbol can be operated on during each selection of Macro symbol/line creation, and all changes made will apply to that macrosymbol. When you have selected the macrosymbol you wish to create or modify, the scrolling menu area displays the Macro details menu.

## Macro details

IGMACRT.DAT, MAC003

Macro details
Macro name
SYMB/LINE (T)
Author
Description of macro

The Macro Details menu consists of boxes for macrosymbol name, type, author, and description. If the macrosymbol exists these boxes will contain the appropriate details. If you are creating a new macro you must give the details yourself, as follows:

**Macro name:** You've already supplied the name and so this appears in the macro name box.

**Symbol / line:** This box displays either Symbol or Line, describing the nature of the macrosymbol. You may toggle between the two descriptions. If it's displaying the wrong description for your macrosymbol then change it by selecting the box.

**Author:** Give your own name (or abbreviation).

**Description:** Any short identifying description of the macrosymbol.

When the details are complete, select Proceed.

In the graphics area the macro you created or selected is displayed against a background mesh (described shortly under *Selection method menu*.)

The static menu displays the following details:

- the macrosymbol name
- the macrosymbol type
- the macrosymbol author

In addition:

*Colours* allows you to change or inspect the macrosymbol environment colours.

*Erase* allows you to erase one or all windows

*Document* gives you access to the MOSS document collection.

## Macro options

IGMACRT.DAT, MAC004

Macro options
Create/modify macro
Save macro
Delete macro
Output macro to file
Reset macro
Exit menu

The actions in the macro options menu operate on the whole macrosymbol.

**Create/modify macro:** This option gives access to the first three menu boxes in the dynamic menu (ADD POINT, DELETE POINT, MOVE POINT) and, through these, to other boxes that subsequently appear in the dynamic menu. You use these to create or modify macrosymbols by creating or moving individual points.

ADD/DELETE/MOVE POINT are inactive unless Create/modify macro is selected and highlighted.

They are documented in the *Dynamic menu* section.

**Save macro:** This stores the macrosymbol to the macro file.

If you have modified an existing macrosymbol you are given the choice of either overwriting the superseded macrosymbol on the macrofile or saving the modified macrosymbol under a new name.

**Delete macro:** Deletes the macrosymbol from the macrofile and blanks the screen. Before deleting, it requests confirmation.

**Output macro to file:** Takes the current macrosymbol as displayed in the graphics area and outputs it to a file, in a format for input to major option MACRO.

This option will prompt for a filename; if you don't respond, the name is read from the switch file (default MACRO.CRD).

**Reset macro:** Erases all modifications made to the current macrosymbol and reinstates the original version. It does not change the macrofile. Before erasing it requests confirmation.

**Exit menu:** Allows you to select another macro or exit the major option. Exit without prior Save macro will force you to save or discard any changes. Quit has the same effect as Exit menu.



**Exit menu or Quit:** Displays a sub-menu:

IGMACRT.DAT, MAC007

Macro options
Macro selection
Exit macro

**Macro selection:** Presents the Macro selection menu again, enabling you to select another macrosymbol.

**Exit macro:** Takes you out of the major option and returns you to the top level (major options) menu.

**Quit:** Has the same effect as Exit macro.

## Selection method menu

### Point selection methods (PSMs)

Whenever an item for point selection is selected in the scrolling menu the current PSM will be highlighted in the selection method area. Any other PSM can be selected at this time.

Point selection methods in Macrosymbol operate in conjunction with a screen grid, or *mesh*. When you select a point in the graphics area, the point actually registered is the nearest node of the mesh that is superimposed over the area.

There are two meshes available: Mesh 1 or Mesh 2. Mesh 1 is the larger mesh and Mesh 2 is smaller. The default is Mesh 1.

MESH 1		MESH 2		POINT
VIS	INVIS	VIS	INVIS	

## MESH

You can make the meshes visible or invisible at any time, by selecting one of the VIS or INVIS boxes adjacent to the box of the mesh (MESH1 or MESH2). When selected and active, the boxes are highlighted.

When you're in a menu that requires a mesh selection point, the mesh that is visible is indicated by the mesh box that is highlighted.

## POINT

Some point selections may require an existing point from the macrosymbol. If this is the case the POINT box will be highlighted.

## Dynamic menu

Some of the boxes in the dynamic menu are for actions that select individual points in order to construct or modify a macrosymbol, some are for actions that operate on whole macrosymbols, and others are simply status indicators.

ADD POINT	DELETE POINT	MOVE POINT	ROTATE	SHIFT	ORIGIN	RESIZE	PEN UP	PERM	TERMIN ELEM	UNDO	POINT	BOX	CHANGE STATE
							PEN DN	IMPERM			ARC	CIRC	

◇ *PERM and IMPERM are not available when designing macrolines.*

## Individual points

The options that enable you to operate on points are ADD POINT, DELETE POINT, and MOVE POINT. You activate them by selecting *Create/modify macro* in the Macro options menu.

## ADD POINT

Gives access to three other boxes simultaneously displayed in the dynamic menu: BEFORE, AFTER, APPEND.

ADD POINT	DELETE POINT	MOVE POINT	BEFORE	AFTER	APPEND	
-----------	--------------	------------	--------	-------	--------	--

**BEFORE.** Adds a new point before an existing point. You select an existing point in the macrosymbol, and then the new point to be added.

**AFTER.** Adds a new point after an existing point. You select an existing point in the macrosymbol, and then the point to be added.

APPEND. Appends a point to the end of the existing macrosymbol. This is the default action. You specify the point you wish to append, and the Pen status indicator determines whether a line is drawn or not.

## DELETE POINT

Gives access to three more boxes simultaneously displayed in the dynamic menu:

ADD POINT	DELETE POINT	MOVE POINT	SINGLE	MULTI	PART MACRO	
-----------	--------------	------------	--------	-------	------------	--

SINGLE. Deletes a single point. You simply select the point to be deleted.

MULTI. Deletes more than one point. You select two points between which you want to delete all the intermediate points ('between' meaning along a polyline).

PART MACRO. Deletes a set of points that comprise a macro element. Examples of macro elements are the individual letters of the MOSS logo, or the arrow part of the northing symbol.

◇ *A part macro or macro element is an element of a macrosymbol which is terminated with an 'element terminator'.*

## MOVE POINT

Moves a single point. You pick the point on the macrosymbol you wish to move, and specify its new position with a second pick.

Beware: This action interprets, and can change, the pen status in order to execute the action, and this can produce results that you might not foresee.

### Example

To add a discontinuity between two points. Select the required point, change the PEN status to PEN UP, then select the new position for the point (the new and previous points may be the same). the point will be redrawn in its new position, but the link from the previous point will have disappeared.

## Macro elements or macrosymbols

Three actions in the dynamic menu, ROTATE, SHIFT, RESIZE, operate on macro elements or macrosymbols. If the current macrosymbol is made up of one or more macro elements you must first select the macro element you wish to operate upon.

The fourth action, ORIGIN, acts only on whole symbols.

## ROTATE

Rotates a macrosymbol.

When you select ROTATE a sub-menu is displayed in the scrolling menu area and you are prompted to select the centre of rotation. When you've done that you must select the direction of rotation from the scrolling menu.

IGMACRT.DAT, MAC005

Rotate Macro
X Point of rotation
Y Point of rotation
Angle of rotation
Clockwise rotation
Anticlockwise rotation

**X/Y point of rotation:** Specify the X and Y coordinates of the point about which you want to rotate the macrosymbol.

**Rotation angle:** Angle of rotation 90 degrees (information only)

**Clockwise/anticlockwise:** Specify by selecting from the menu.

◇ *The only permitted rotation angle is 90 degrees.*

**SHIFT**

Shifts a whole macrosymbol in any specified direction.

You specify the shift by selecting two mesh points in the graphics area. The shift between the two points is the shift that is applied to the macro.

**ORIGIN**

Moves the origin of the macrosymbol to a new origin.

You select the point in the graphics area that you wish to be the new origin.

**RESIZE**

Reduces or increases the size of the macrosymbol.

To specify the resizing, you type in X,Y scale factors.

◇ *Distortion may be caused dependent upon the scale factor used.*

## Status indicators

The next two boxes in the dynamic menu are pen status indicators. They are automatically highlighted when relevant.

### PEN UP/DOWN (TOGGLE)

PEN DOWN indicates that the current pen status is DOWN (that is, drawing).

PEN UP indicates that the current pen status is UP (not drawing). However, this will change to DOWN when,

- the next point selection is made
- Add point is selected.

### PERM/IMPERM

Indicates that the element being drawn is either permeable or impermeable. A permeable element is made up of lines forming a polygon that can be crossed by other drawing elements. An impermeable element is made up of lines forming an impermeable (clip) polygon that cannot be crossed by other drawing elements.

- ◇ *When permeable is set the pen up option is only a single action. At the next selection pen down and permeable will automatically reset.*
- ◇ *When impermeable is set the pen up or pen down status cannot be changed until the current element has been terminated.*

### ELEMENT TERMINATOR

Marks the end of the macro or a macro element. When you select this box, a marker known as an element terminator is inserted into the macro.

### UNDO

Erases the most recent modification, leaving the macrosymbol as it was before the last modification. **Beware**, you can use this only once. In other words, if you select UNDO, UNDO, UNDO, you will get an error condition.

### CHANGE STATE

Changes a permeable line to an impermeable line and vice-versa.

## Line definition

Gives access to four boxes (POINT, BOX, CIRCLE, ARC) displayed in the dynamic area, which you use to define the position of lines by specifying the position of points, boxes, circles or other arcs.

Beware: POINT is the default, but if you select ARC it will remain current until changed.

POINT. You are prompted for one point.

BOX. You are prompted for two points that are diagonally opposite corners of the box.

CIRCLE. You are prompted for the centre point and radius.

ARC. You are prompted for any three points along the arc.

# Major option UPM

## Description

The User Programmable Module (UPM) allows you to write and execute command files and packages under the control of MOSS. Commands are in the form of a BASIC-like programming language with additional functions specifically designed to access MOSS data. Command files processed within UPM can therefore run MOSS options and then act upon the results. UPM can be invoked from either MOSS IGMODE or Linemode. In both modes the UPM can be made interactive, requesting information from the user whenever necessary.

## Method of use

UPM command files contain lines of BASIC-like language commands which when run will function as a simple program. UPM can perform simple programming tasks, such as OPEN, and CLOSE files, get input, write output and manipulate variables. More complex commands and functions have been added to the basic functionality. These permit MOSS modelfile accessing, customised IGMODE menus, data handling and interpretation. MOSS input data can be interspersed within a command file and is run through MOSS when it is reached. If you have purchased the development option you can create your own command files using all these powerful capabilities. You are not constrained by the facilities offered within the MOSS program and you can choose to develop your own style of report or develop your own design options applying your own criteria.

- ◇ *For full details of available commands and how to develop, manage and distribute UPMs, refer to the 'MOSS Guide to UPMs'.*

## Invoking a UPM

Major option UPM can only be used to run command files or packages which have been scrambled. To run unscrambled command files, you must have a development licence and you must use major option UPMD to invoke them. See the 'MOSS Guide to UPMs' for further details.

If you wish to change the default location of the UPM directory containing command files, you should modify UPMDIR in your switch file so that it points to the new directory.

## Input

### Graphics

To invoke a command file from IGMODE, select the UPM button at the foot of the screen and specify the name of the command file you wish to invoke.

- ◇ *The LIST and MASK facilities may be used to list the available command files.*

### Linemode

Major option UPM

Model 1      Name of command file to be invoked.

If blank, the UPM system is reinitialised, ie, variables are initialised, file unit numbers are reset, etc.

If the suffix is not specified, it is assumed to be '.upm'.

To run a command file that does not reside in the UPM directory, include the full pathname.

- ◇ *Command files which use UPM IG commands can only be invoked if IGMODE has already been used.*

### Example

To run a command file called 'optpad.upm':

```
UPM, OPTPAD
```

In the example, the file 'optpad.upm' is submitted to the command interpreter and control is returned to you once the end of the command sequence is reached.

The command file may also be invoked from within a MOSS data file which is run in a background process, but UPM cannot be invoked through INPUT.



# Chapter 14 External Interfaces

## External Interfaces

MOSS has been designed as an independent computer system and it provides a comprehensive range of facilities. However, it is often desirable to be able to transfer information into or out of the MOSS system to permit interfacing with other independent systems.

The major options covered in this chapter are:

- Major option GENIO
- Major option 3DDXF

These are followed by external programs. The programs are:

### *Data Collection*

Site Measurement Module  
MSSMTRANS  
MSOSPP  
ORDSDRAW

### *Data Conversion*

MSMODCNV  
MSDPFCNV

### *Drainage Design*

WALLRUS  
MICRORAT

### *Graphics*

MSPLOTTER  
MSMIFILE  
MS2DDXF  
MSDXFMOSS  
MSMINT  
MSDAMS

### *EPIC*

MSSHOW

### *Documentation*

MSDOCUMENT

### *UPM*

MSCRMENU

## Major option GENIO

GENIO is a GENeralised Input and Output option. It may seem desirable to develop a standard interface format, but because of the variation in the content of the data to be transferred and the need to reformat and assemble

the required information, each of the requirements is considered as an independent function within major option GENIO.

There are occasions when it is necessary to prepare model information external to the MOSS system. This will apply particularly to survey information prepared by independent companies.

The option is also needed when transferring model information between installations which have different computer configurations and card image format is the only practical medium for transfer.

The above facilities are provided by a series of minor options as follows:

Option	Description
080	General input of n-dimensional strings on the standard MOSS input device
081	General output of n-dimensional strings to an external file
082	Input of sectional information
083	Output of sectional information for use, with section based software.
085	Partial output of triangulation.
087	Output of sectional information for the drainage design program SAFRON.
089	Full output of triangulation
090	Full input of triangulation

◇ *Major options ASSIGN and OVERWRITE can be used in conjunction with GENIO to direct the output of minor options 081, 083, 085 and 089 to a specified file. This application is particularly appropriate when constructing UPMs.*

As the major option is an input/output orientated option there are two kinds of data which for the purposes of explanation may be classified as follows.

### Control data

This is the minor option data which actually controls the major option. It is always in MOSS standard format and is input via the standard input device.

### Model data

This is the string information forming the model to be input or output. Model data to be input to MOSS will follow the control data on the standard input device. Model data to be output from MOSS will be written to the GENIO output channel.

## Access to major option GENIO

Major option GENIO

- Model 1      Model from which information is to be extracted or to which information is to be sent.
- Model 2      Model containing reference strings required by particular options if not in first model.

For example, when creating a file of cross sections, the first model will contain the sections and the second will contain the reference string on which the sections are based.

## Qualifying minor options

In order to simplify the data preparation for options 080 and 081 the system assumes a default data format for the external files as that of the model file.

By using qualifying minor options it is possible to change the format of the data on the external file and the order in which the data items are stored.

Further facilities can be invoked to change the units of angular measure on output, to select groups of strings and to invoke the data checking facility when reading input with the minimum of file editing.

The qualifying options are best used to format and order the external file so that, for example, sectional information may be prepared for an independent system with the minimum of file editing.

The qualifying minor options are as follows:

001 (FORMAT)	Define the format of the external file or the incoming string
003 (ORDER)	Define the order of items within a string element on the external information file or within the incoming string
017 (ANGLE)	Change the form of angular information
018 (DATA CHECK)	Invoke data checking. Request output of header information
019 (MASKS)	Select strings to be output
001 (FORMAT)	Define the format of the external file or the incoming string
003 (ORDER)	Define the order of items within a string element on the external information file or within the incoming string
017 (ANGLE)	Change the form of angular information
018 (DATA CHECK)	Invoke data checking. Request output of header information
019 (MASKS)	Select strings to be output

Should no particular restriction be applicable then the qualifying minor options need not be used, since defaults are already set up within the program: however should they be used they must be coded before the minor option to which they relate.

```
eg      001 FORMAT
        080
        999
```

is correct whilst

```
080
001 FORMAT
999
```

is incorrect.

### Example

When outputting strings of varying dimensions without using defaults, it may be necessary to code a combination of qualifying options eg.

```
001,FORMAT(3F10.3,A4)
003,ORDR,4=1,1,2,3,4
019,PSS,4=1
019,4=-1
081
001,FORMAT(6F10.3)
003,ORDR,4=3,1,2
019
019,D,4=1
019,0,4=1
019,4=-1
081
```

## Minor option 001 Change format

Changing the format of the information (optional)

Although the major and minor options are always in MOSS standard form the string data may be formatted in such a manner that it may be used in other applications. The default formats are automatically invoked, if this minor option is not defined. A change of format should be used to accommodate strings of different dimensions and also according to whether information is being input or output.

The default formats are as follows:

Option	Dimension of string	Format of record per record	No. of Points
080 (input)	2	6F10.3	3
	3	6F10.3	2
	5	5F10.3	1
	6	6F10.3	1
081 (output)	All strings are output with one point per record Numerical information is D23.17 (default) Text information is A4		

The final output format is dependent on type of string and dimensionality.

It should be noted that section strings are five dimensional but the fifth dimension consists of four alphabetic characters. If the data for section strings is to be intelligible the following formats should be used:

Option 080 4F10.3,A4  
081 4F12.6,A4

The use of D or E format (eg 4E18.6) on outputting model data allows a greater number of significant figures to be retained.

## Input

### Minor option 001

All fields Code a complete Fortran format statement to define the interpretation and position of the items input/output eg  
001,FORMAT (4F10.3,A4)

◇ *When outputting in a user defined format an 003 option should also be defined if the data is to be read into MOSS. The default formats on output (081) differ from those on input (080).*

The format is described by a number of field descriptors separated by commas and is contained within parenthesis.

A field descriptor in a format specification has the form:

[r]Cw[.d]

where r represents a repeat count which specifies the field descriptor is to be applied for 'r' successive fields. The default is 1 if omitted.

C is a format code as follows:

Code	Format
------	--------

I	Integer
A	Alpha character
X	Space
F	Real number
D and E	Double precision

w specifies the width of the field.

d specifies the number of decimal places

The character / has the additional function of splitting records so that data can be read/wrote to multiple lines.

## Minor option 003 Change order

Changing the order of the items of information in a string element.

The first two dimensions of a point on any string are always cartesian coordinates, but the other dimensions may describe different properties of the point. For example, for a 6D M-string the fourth dimension is chainage whilst for a section string the fourth dimension is the offset of the point from the origin point.

For different applications the order of the dimensions may need to be varied. A common example will be in specifying the points of a horizontal alignment to be output as

Chainage, Easting, Northing, Bearing, Radius rather than the standard Easting, Northing, Level, Chainage, Bearing, Radius.

Another use of this option is for allowing data to be compacted (or expanded). For example, if a two dimensional string has coordinates of only four significant figures the number of points per record for output may be increased from the default 1 point per record to 10 points per record.

### Input

#### Minor option 003

Field 1	ORDR
Field 4	No of Points per record (if blank 1 is assumed)
* Field 5	Code the dimension of the first item to be input/output
* Field 6	Code the dimension of the second item to be input/output
* Field 7	Code the dimension of the third item to be input/output
* Field 8	Code the dimension of the fourth item to be input/output
* Field 9	Code the dimension of the fifth item to be input/output
* Field 10	Code the dimension of the sixth item to be input/output

### Example 1

If for a 6D string the items were to be output as Chainage, Easting, Northing, Bearing, Radius the necessary ORDR record would be:

```
003,ORDR,4=1.0,5=4.0,6=1.0,7=2.0,8=5.0,9=6.0
```

### Example 2

If a 2D string only has coordinates of 4 significant figures the amount of data per record may be increased by the following:

```
001FORMAT(20F4.2)
003,ORDR,4=10.0,5=1.0,6=2.0
```



## Minor option 017    Change angle

If the string information to be output contains angular information such as exists in a horizontal alignment string it may be necessary to define the form the angular information is to take. Angular information in strings is always held in radians in the model file and it may be specified differently for input or output.

### Input

#### Minor option 017

Field 1        Input angle definition (option 080)

Field 2        Output angle definition (option 081)

The Angle definition is as follows:-

GRAD        angular information defined as grads.

RADI        angular information defined as radians.

DEGR        angular information defined as degrees and decimals.

DMS        angular information defined as degrees and minutes and seconds (in the format D23.17).

QUAD        angular information defined as quads.

Further explanation of global minor option 017 is contained Chapter 2.

## Minor option 018    Check data

The purpose of this minor option is to allow some of the default features relating to the input or output to be changed. These features are:-

- Although Data is non-standard format, data may be vetted for errors.
- On outputting information the header data consisting of the Major option, Minor option 080 and qualifying minor options may be suppressed.

The necessity for feature 1 is that although the control data is in MOSS standard format and therefore has comprehensive data vetting automatically carried out on it, the model data is non-standard and data-vetting is not automatic. Most of the model data will be prepared by some form of automatic process and data checking for invalid characters is unnecessary.

The facility does exist whereby each record can be checked and this invokes a processing overhead and should be used with care. The facility is equally applicable to user defined formats or the default formats but it should be noted that only 'A', 'F', or 'I' formatted data may be checked (ie E12.6 type information may not be checked), and only ',' is valid as a delimiter (ie 'I' will produce an error).

Minor option 081 will sometimes be used to output information applicable to another suite of program in which case the header information will be redundant and may be suppressed.

## Input

### Minor option 018

Field 1            If data checking is to be invoked code CHEK. If data checking is not required code NOCH.

The default situation is that data checking is not required.

Field 3            Code NOQU if header information is to be suppressed.  
Code QUAL if header information is to be output.

The default situation is QUAL.

### Minor option 019 Define selection mask

This facility is only applicable for minor option 081 the output of information. It is fully described in Chapter 2.

### Minor option 080 General input of strings

#### *User defined format*

Minor option 080 stores string information created external to MOSS, such as ground survey information produced by contract, or restores a model previously created by minor option 081.

String optimisation reduces the amount of string point information contained in a mode. The general input of strings is processed to remove any points which are within the tolerance defined for the horizontal, vertical or 3D plane.

You can select the preferred optimisation method from 'HORZ,' 'VERT' or 'BOTH' (for 3D). Horizontal optimisation is available for 2D and 3D strings, Vertical optimisation to 3D and 5D (section strings only) and 3D optimisation to 3D and 5D (section strings only).

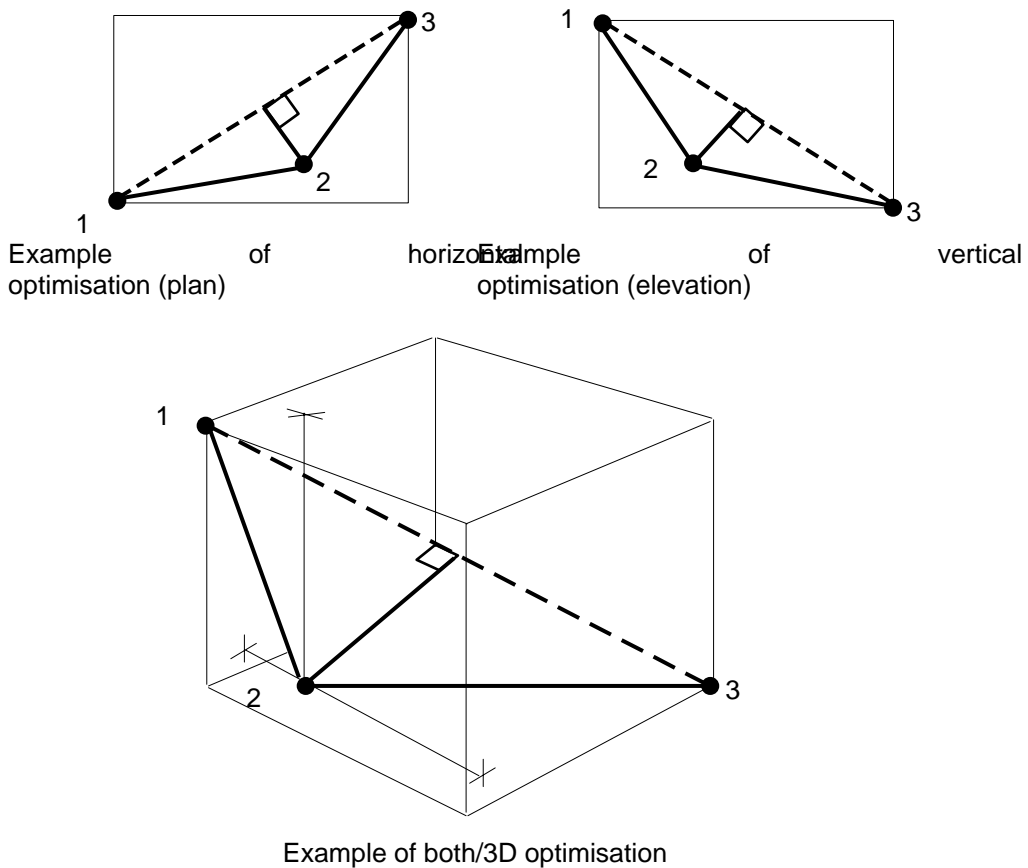


Figure 14 - 1 Examples of string optimisation

## Input

### Linemode

#### Minor option 080

Field 1	String label
Field 2	Sub reference (if required)
Field 3	Optimisation method 'HORZ', 'VERT' or 'BOTH' (default blank, or Horz if field 10 is coded)
Field 4	Contour level for a 2D string
Field 5	Origin easting (optional)
Field 6	Origin northing (optional)
Field 7	Dimension of string being created
Field 8 & 9	String terminator

This is the number combination which is used to signify the end of the string. The default values will be 0.0, 0.0. If a string is to be input with the coordinates (0.0, 0.0) then another combination such as 999999.9, 999999.9) or -1.0, -1.0 must be used

Once the default terminator has been changed it remains current for the rest of the MOSS session.

Field 10	Optimising tolerance (default blank or 0.005 if field 3 is coded) The use of an optimising tolerance allows the removal of points from the stored data which are within the defined tolerance. This process is identical to the data reduction method used within major option DIGIT.
----------	--

- ◇ *If the optimising tolerance in field 10 is coded and the optimisation method in field 3 is not specified, the optimisation method will default to 'HORZ'. If field 3 is coded but the optimising tolerance field 10 is not, a warning message will appear.*
- ◇ *Where it is necessary to relabel any of the incoming strings the standard convention will be followed.*
- ◇ *The string information follows the minor option data according to the standard default format of F10.3 with the number of points per record as shown. If this number is to be changed use option 003.*
- ◇ *The origin easting and northing are added to each first and second dimension of the point information. They are not local grid coordinates but merely facilitate data preparation in that on subsequent records only the x and y differences need to be coded.  
If columns 1-20 (assuming the default format) in the string information which follows represent genuine negative coordinates, use fields 5 and 6 to code the same X and Y shifts as those used in the parameter file. Otherwise the negative values will be interpreted as discontinuities in the string.*
- ◇ *For information about string types and the data stored for each string type, refer to Chapter 2.*

String information

**2D strings** - 3 points per record

*Columns*

1 - 10	Easting	) First point
11 - 20	Northing	)
21 - 30	Easting	) Second point
31 - 40	Northing	)
41 - 50	Easting	) Third point
51 - 60	Northing	)

**3D strings** - 2 points per record

*Columns*

1 - 10	Easting	)
11 - 20	Northing	) First Point
21 - 30	3rd Dimension (Level)	)
31 - 40	Easting	)
41 - 50	Northing	) Second Point
51 - 60	3rd Dimension	)

**4D, 5D, 6D strings** - 1 point per record

*Columns*

1 - 10	Easting
11 - 20	Northing
21 - 30	3rd Dimension
31 - 40	4th Dimension
41 - 50	5th Dimension
51 - 60	6th Dimension

- ◇ *Sufficient records of the above format are coded to define the string. To terminate a string a set of coordinate values of 0.0 must be coded or the number combination to be used as a terminator as defined on the 080 minor option. It should be noted that a full record needs to be coded for the last record. This is particularly important if a non standard format has been defined which considers each full record to consist of two card images, ie those containing a '/' record in the format.*
- ◇ *The subsequent record will either be another 080 record or a minor option 999 which terminates the major option.*
- ◇ *The inclusion of a discontinuity within a string is accommodated by indicating the start of the discontinuity with a negative x value and the end of the discontinuity with a negative y value.*
- ◇ *Bearing discontinuities are accommodated by negating both the X value and the Y value.*
- ◇ *The order of items within each string element and the record format may be different to that described and may be defined using 003 and 001 minor options.*
- ◇ *The use of the horizontal optimisation method in association with 3D strings will ignore vertical point information when calculating which*

*points can be removed, and the use of the vertical optimisation method will ignore horizontal point information.*

- ◇ *Optimising strings which are close together could cause overlapping of strings, as points within the optimising tolerance are removed.*

**Cadastre string - 1 point per record**

Default format is (2F13.3, 2F11.3, A8, A4, 4A4).

A cadastre string is a point string with a subreference of either SHEE or NORT.

Data dimension	Columns	Data
1	1 - 13	X (eg F13.3)      minimum data required
2	14 - 26	Y (eg F13.3)
3	27 - 37	Z (eg F11.3) -999.0 must be coded for points with a null level.
4	34 - 48	Symbol reference bearing (F11.3) current input angular units.
5	49 - 56	Integer survey point number (A8 alphanumeric)
6	57 - 60	Feature code (A4)
7	61 - 76	Cadastre point number (4A4)

- ◇ *If incomplete data is supplied a null value will be assigned to data dimensions 4 to 7.*
- ◇ *Option 003 is not permitted with this string type.*
- ◇ *Option 001 is mandatory for this type of string information as it contains alphanumeric characters.*
- ◇ *If this string information is added to a model already containing P strings, it will be appended if the existing string has an identical label, subreference, and contents indicator. Otherwise relabelling will occur.*

*Input of alphanumeric strings*

Alphanumeric strings which have the initial character '\*' differ from other types of string in that they can be of different dimensions. The first four dimensions describe the position and orientation of a set of characters and the remainder of the dimensions contain up to 44 characters. An alphanumeric string can consist of many elements each containing a set of characters.

For such strings the default input formats are unsuitable and they need to be marked. They are then accessed separately and the most convenient format to input the strings is:

001,FORMAT(4F10.3,/,11A4)

The oblique will cause each string to consist of 2 records with all the character information on the second. It should also be noted that when information is input, the terminating data needs to consist of 2 records as the whole format needs to be read, and although the information of the second record is dummy, it should not be left blank.



## Minor option 081    General output of strings

### *User defined format*

This minor option outputs string information from the MOSS model file to an ASCII file. The most likely use of this option will be the transfer of model information from one installation to another where the configurations are different and only ASCII files are compatible. For this reason the data output is created in such a manner that it may be used directly as input using minor option 080 and contains the GENIO major option record, the minor option 080 record, certain qualifying minor options and the string information.

The string information is output in a format appropriate to the dimension and style of string. However, should it need to be different then minor option 001 may be used to change it. It should be remembered that information may only be output in an equivalent format to that which it is stored, integer information may only be output with I format and real with D, E or F format. Where information is to be used by another computer system it is preferable to use D or E format for the data since this does not lead to the loss of numerical precision associated with F format, and option 001 may be used to redefine the format.

The 018 minor option may be used to suppress the output of the header information including the GENIO major option record, the 080 minor option record and qualifying minor options.

The output of this minor option will be an external sequential 80 column formatted ASCII file which may be used directly in recreating the data using minor option 080.

The output string information is not in the F10.3 format, which is standard for the option 080, but in D23.17 so as to accommodate greater accuracy.

### Input

#### Minor option 081

- |             |   |
|-------------|---|
| Fields 1    | Label of string to be output. If omitted all strings, or all strings satisfying a predefined selection mask table, will be output.  |
| Field 3     | Label to be assigned to string when output (optional) eg if only the first three dimensions of a 6D string are to be output then it may be necessary to call the output string 0C01 (say) instead of M001.      |
| Field 4     | Chainage Interval. May be specified for a master alignment and may be a multiple of the original interval. If omitted all points in the string are output.  |
| Field 5 & 6 | Standard point reference data for the start of the string.  |
| Field 7     | Number of items per string element to be output. If blank all items are output, eg in the above example for the output of the first three dimensions of a 6D string the value coded in this field would be 3.0. |
| Field 8 & 9 | Standard point reference data for the end of the string   |



- ◇ *The coding of fields 5, 6, 7 and fields 8, 9 allow parts of strings to be output. If two different parts of a string are output and then re-input there will be two independent strings created.*
- ◇ *If field 1 is left blank and therefore more than one string is to be output then the strings will be sorted prior to being output in ascending alphabetic order (ie A-Z, 0-9). The reason for this is to ensure that when strings are reloaded into a model efficient checks may be made on the uniqueness or otherwise of the string label.*
- ◇ *Option 081 outputs the full 'contents indicator' in field 7 of the 080 record, instead of the dimension of the string. This assists with re-input of the string into MOSS.*
- ◇ *A file output by option 081 will include current angular units as defined by option 017.*
- ◇ *Cadastre strings - where dimensions are undefined, zero or space characters are used in the file output by option 081.*

Example

```
GENIO SAMPLE GROUND MODEL
081, F001, 3=C001, 6=4.0, 9=1.0
999
```

The output to the example above would be as follows:-

```
GENIO SAMPLE GROUND MODEL
001FORMAT(3D23.17)
003,ORDR,4=1,1,2,3,
080,C001, ,5= 0.0, 0.0,100007703
0.50124174061478925D+060.11112685972059182D+060.6401600000000000D+02
0.50123300490568221D+060.11112534639845585D+060.6427600000000000D+02
0.50122350753502582D+060.11112403982491664D+060.6453600000000000D+02
0.50121353397463507D+060.11112299746459879D+060.6539600000000001D+02
0.0000000000000000D+000.0000000000000000D+000.6539600000000001D+02
999
FINISH
```

*Non-standard output of strings*

Example of the use of minor option 081 with qualifying minor options to produce 'non-standard' output.

GENIO may be used for MOSS to MOSS transfer of data, but it may also be used to generate the data requirements of other systems or processes. For example it is becoming common to download surveying and setting out details into data collectors for subsequent recall in the field. The following illustrates this typical use.

A sample format of data collector records required for Instrument Station details are as follows:-

Cols.

- 1 - 2 Record Type Code (say 08)
- 3 - 4 Derivation Code (say MS)
- 5 - 8 Point Number

9 - 18        Northing  
19 - 28        Easting  
29 - 38        Level  
39 - 54        Description

In the MOSS database the station details would be stored in a 4D string labelled by default PSSA whose dimensions are (Easting, Northing, Level, Station Name). The original Point Number is not available for output.

Records of the above type may be produced by qualifying the option 081 option by associated minor options 001, 003 and 018.

### Example

```
GENIO, STATIONS MODEL
      SUPPRESS QUALIFYING INFORMATION
018, 3=NOQU
      FORMAT THE RECORDS
001, FORMAT('08MS', '0000', 3F10.4, A4)
      ORDER THE DIMENSIONS - NOTE THAT EASTINGS AND
      NORTHINGS ARE SWAPPED
003, ORDR, 4=1, 2, 1, 3, 4
      OUTPUT THE STRING
081, 1=PSSA
999
```

The output from the above would appear as follows, and the user would be able to edit additional information as appropriate.

```
08MS0000111228.426501515.678 46.353STNA
08MS0000111198.347501445.746 51.736STNE
08MS0000111168.496501376.343 56.897STNG
08MS0000111137.001501303.120 61.056STNB
08MS0000111114.127501197.642 64.506STNC
08MS0000111180.403501244.076 69.720STNN
08MS0000111195.408501325.380 65.180STNK
08MS0000111221.886501396.621 60.150STNL
08MS0000111245.109501468.524 54.600STNM
08MS0000111175.228501486.109 43.260STND
08MS0000111174.996501435.109 49.630STNF
08MS0000111119.931501340.401 54.590STNH
08MS0000111097.972501267.643 58.560STNJ
```

### *Output of alphanumeric strings*

This operates in a similar fashion to minor option 080, 'Input of alphanumeric strings'.

Alphanumeric strings may be automatically output using default formats.

## Minor option 082 Input of section information

### Standard format sections

The section information is presented as a series of offsets and levels. For the sections to be stored as MOSS section strings each point requires its coordinate value. It is therefore necessary to store the master alignment from which the sections were generated and this alignment should be stored in the second named model. From this information the option determines the plan coordinates and stores the section as MOSS sectional strings.

### Input

- 1st model      Contains the model in which the section strings are to be stored.
- 2nd model      Contains the model in which the reference string resides. If it is left blank the first model will be searched for the reference string.

### Minor option 082

- \* Field 1            Master alignment string label.
- \* Field 3            Section string label initial characters eg Sbbb

The sectional information now follows

	Columns
Record A -	
Chainage of section (Real number with decimal point)	1 - 10
No. of points in section (Integer number, right justified) must be in the range 1 – 50)	11 - 18
Record B -	
Offset	11 - 18
Level	19 - 26
Offset	27 - 34
Level	35 - 42
Offset	43 - 50
Level	51 - 58
Offset	59 - 66
Level	67 - 74
Level	67 - 74

There are as many records type B to accommodate the number of points as defined on record type A.

There are as many records type B to accommodate the number of points as defined on record type A.

There are as many records type A and B to define all the sections.

Record C - 999999.999 1 - 10

The effect of the minor option is to generate a series of section strings from the sectional information which are related to the master alignment. Note

that only sections whose chainage occurs on the alignment may be processed.

No data vetting of record types A, B and C is carried out.

*SYSTEM 050 sections*

The computer system SYSTEM 050 is used by M.T.C. Ontario.

The section information is presented as a series of offsets and levels in a format compatible with SYSTEM 050. For the sections to be stored as MOSS section strings each point requires its coordinate value. It is therefore necessary to store the master alignment from which the sections were generated and this alignment should be stored in the second named model. From this information the option determines the plan coordinates and stores the sections as MOSS sectional strings.

**Input**

1st model      Contains the model in which the section strings are to be stored.

2nd model      Contains the model in which the reference string resides. If it is left blank the first model will be searched for the reference string.

**Minor option 082**

- \* Field 1      6D M-string label
- \* Field 2      Code SY50. This indicates that the model data is in SYSTEM 050 format.
- \* Field 3      Section string label initial characters eg Sbbb

The sectional information now follows.

	Columns
Record A -	
Chainage of Section (Real number with decimal point)	1 - 12
No. of points in Section (Integer number, right justified) (must be in the range 1 - 1000)	18 - 20
The following 2 fields may be filled in but will be ignored by the program.	
Section String label (4 characters)	26 - 30
Master String label (4 characters)	36 - 40
Record B -	
Intersected String Label	1 - 4
Offset	5 - 12
Level or Elevation	13 - 20
Intersected String Label	21 - 24
Offset	25 - 32
Level or Elevation	33 - 40
Intersected String Label	41 - 44
Offset	45 - 52
Level or Elevation	53 - 60
Intersected String Label	61 - 64
Offset	65 - 72

Level or Elevation

73 - 80

There are as many records type B to accommodate the number of points as defined on record type A.

There are as many records type A and B to define all the sections.

Record C -999999.999

1 - 12

The effect of the minor option is to generate a series of section strings from the sectional information which are related to the master alignment. Note that only sections whose chainage occurs on the alignment may be processed.

No data vetting of record types A, B, and C is carried out but if more than 250 points, are defined on Record A then the number is declared out of range and an error ensues.

## Minor option 083    Output of section information

### *Standard format sections*

This option creates sectional information from a MOSS model and is therefore the reverse of option 082.

It should be noted that only cross-sections may be output using this option. Longitudinal sections may be effectively created by recourse to minor option 081.

### Input

- 1st Model    Contains the model from which the section information is taken.
- 2nd Model    Contains the reference string on which the sections are based. If left blank the first model will be searched for the reference string.

### Minor option 083

- \* Field 1        Section string label for the first section to be output
- Field 5 & 6    Standard Point Reference Data for start point on reference string for sections to be output
- Field 7        Chainage Interval (optional)
- Field 8 & 9    Standard Point Reference Data for end point on reference string to be output.

The output of the section information is identical to the model data required by option 082 except for the end of the data which is signified by END in the first 3 columns of the last record output.

### Example

```
GENIO, THORNBOROUGH INTERCHANGE
083, G001, 5=3900.0, 7=100.0, 8=4700.0
999
```

Would produce the following output -

```

3900.000      3
-141.232 133.000 22.123 132.000 158.690 131.000
4000.000      4
-174.128 133.395 -76.863 133.000 75.295 132.000 163.416 131.000
4100.000      5
-92.937 133.000 -64.108 133.059 -42.851 133.000 40.659 132.000
156.270 131.000
4200.000      6
-431.374 132.000 -40.966 132.000 -15.939 132.204 5.685 132.000
108.260 131.000 189.340 130.000
4300.000      4
-342.855 131.000 -48.701 131.000 48.401 131.000 129.386 130.000
4400.000      9
-400.905 131.000-292.189 130.000-242.652 129.900-210.475 129.947
-178.298 130.000 -68.346 131.000 0.882 131.000 80.133 130.000
149.347 129.000
4500.000      9
-447.613 131.000-359.806 130.000-345.411 129.942-325.652 130.000
-163.016 131.000 -35.196 131.000 33.224 130.000 114.812 129.000
189.990 128.000
4600.000      6
-465.256 131.000-342.855 131.000 -78.103 131.000 -26.528 130.000
39.161 129.000 120.971 128.000
4700.000     11
-325.884 131.000-241.122 130.000-146.915 129.339-115.513 129.000
-52.253 128.000 -6.710 127.000 32.218 126.000 85.215 126.000
108.832 126.054 132.449 126.000 166.225 125.968
```

*SYSTEM 050 sections*

This option creates sectional information from a MOSS model and is therefore the reverse of option 082.

The output is to a formatted ASCII file which will require the program header information to be edited into it. It should be noted that only cross-sections may be output using this option.

**Input**

- 1st Model     Contains the model from which the section information is taken.
- 2nd Model     Contains the reference string on which the sections are based. If this field is left blank the reference string will be assumed to reside in the first model.

**Minor option 083**

- \* Field 1       Section string label for the first section to be output
- Field 2       Code SY50. This indicates that the model data will be output in SYSTEM 050 format.
- Field 5 & 6     Standard Point Reference Data for start point on reference string for sections to be output
- Field 7       Chainage interval (optional)
- Field 8 & 9     Standard Point Reference Data for end point on reference string for sections to be output.

The output of the section data is identical to the model data required by option 082 (SYSTEM 050) except for the end of the data is signified by both a 999999.9 record and also a record containing END in the first 3 columns.

**Example**

The data

```
GENIO,NEW THORNBROUGH GROUND MODEL
083,G,SY50,5 = 3900.0,7 = 100.0,8 = 4700.0
999
```

would produce an ASCII file of output as follows.

```

3900.000      3      G001      M003
0003-141.232 133.0000004 22.123 132.0000005 158.690 131.000
4000.000      4      G005      M003
000N-174.128 133.3950003 -76.863 133.0000004 75.295 132.0000005 163.416 131.000
4100.000      5      G009      M003
0003 -92.937 133.000000N -64.108 133.0590003 -42.851 133.0000004 40.659 132.000
0005 156.270 131.000      6      G00D      M003
4200.000      6      G00D      M003
0004-431.374 132.0000004 -40.966 132.000000N -15.939 132.2040004 5.685 132.000
0005 108.260 131.0000006 189.340 130.000
4300.000      4      G00H      M003
0007-342.855 131.0000007 -48.701 131.0000005 48.401 131.0000006 129.386 130.000
4400.000      9      G00L      M003
0007-400.905 131.0000008 -292.189 130.000000M-242.652 129.900 -210.475 129.947
0008-178.298 130.0000007 -68.346 131.0000005 0.882 131.0000006 80.133 130.000
0009 149.347 129.000      9      G00P      M003
4500.000      9      G00P      M003
0007-447.613 131.0000008 -359.806 130.000000M-345.411 129.9420008-325.652 130.000
0007-163.016 131.0000005 -35.196 131.0000006 33.224 130.0000009 114.812 129.000
000A 189.990 128.000      6      G00T      M003
4600.000      6      G00T      M003
0007-465.256 131.0000007 -342.855 131.0000005 -78.103 131.0000006 -26.528 130.000
0009 39.161 129.000000A 120.971 128.000
4700.000      11     G00X      M003
0005-325.884 131.0000006 -241.122 130.000 -146.915 129.3390009-115.513 129.000
000A -52.253 128.000000B -6.710 127.000000C 32.218 126.000000C 85.215 126.000
108.832 126.054000C 132.449 126.000 166.225 125.968
999999.900      0
END

```

## Minor option 085 Partial output of triangulation

This option creates a file of data describing a triangulation model created by major option TRIANGLE. It is similar to the data file generated by minor option 946 for triangulation models created by major option CONTOUR.

The data output cannot be re-input to MOSS to create a triangulation (use ARCHIVE and RETRIEVE to transfer triangulation models). It is intended that the data file be used as input to either standalone visualisation programs, or to other systems.

For full triangulation output which can be re-input to MOSS, use minor option 089, 'Full output of triangulation'.

The default output of this option is

4I7,3X,A4,5X,3F12.3/3F12.3,4X,3F12.3

which creates two lines of data.

The default format is

FORMAT (4I7,3X,A4,5X,3F12.3/3F12.3,4X,3F12.3)

Line 1 The variables output are  
MTRI,I1,I2,I3,BDRY,X1,Y1,Z1

Line 2 The variable output are  
X2,Y2,Z2,X3,Y3,Z3

Where (X1,Y1,Z1); (X2,Y2,Z2); (X3,Y3,Z3) are the vertex coordinates of triangle MTRI and I1 is the triangle adjacent to side 1, I2 is the triangle adjacent to side 2 and I3 is the triangle adjacent to side 3. BDRY is the name of the boundary string (if coded).

If I1, I2 or I3 is zero then the related side of MTRI is an edge of the triangulation. Negative values of I1, I2 or I3 indicate that the triangle side between the two adjacent triangles was generated from an original string link.



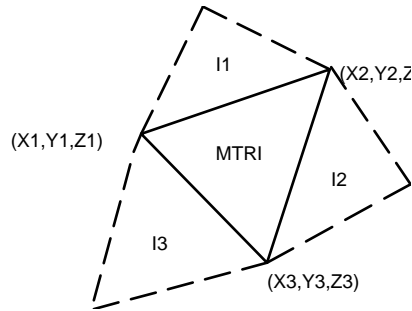


Figure 14 - 2 Example - Output triangulation to a file

◇ For each triangle the value of Y1 and that of X3 will always be negative. This is to follow the GENIO convention indicating the end and beginning of discontinuities.

Minor option 085 cannot be combined with other GENIO minor options as it uses a triangulation model type.

Input

1st Model Contains the triangulation model. This must be a TRIA model type.

Minor option 085

\* Field 1 Triangulation label

Example 1

```
CREATE ISOTEST
EDIT ISOTEST
009,3=XXXX,5=1100,1100,100,1100,1200,100
009,3=XXXX,5=1200,1200,100,1200,1100,100
999
CREATE ISOTEST TRIANG
TRIANGLE,ISOTEST
TRIANGLE,ISOTEST TRIANG
960,3=TRI1
999

GENIO,ISOTEST TRIANG
085,TRI1
999
FINISH
```

Would produce the following listing

1	0	2	4	600.000	-600.000	-999.000		
600.000			1700.000	-999.000	-1000.000	1100.000	-999.000	
2	1	5	-8	1000.000	-1000.000	-999.000		
600.000			1700.000	-999.000	-1100.000	1200.000	-999.000	
3	5	7	-10	1100.000	-1200.000	-999.000		
1700.000			1700.000	-999.000	-1200.000	1200.000	-999.000	
4	69	0	1	1100.000	-1100.000	-999.000		
1700.000			600.000	-999.000	-600.000	600.000	-999.000	
5	2	0	3	1100.000	-1200.000	-999.000		
600.000			1700.000	-999.000	-1700.000	1700.000	-999.000	
6	80	9	-9	1200.000	-1100.000	-999.000		
1700.000			600.000	-999.000	-1100.000	1100.000	-999.000	
7	3	6	-8	1200.000	-1200.000	-999.000		
1700.000			1700.000	-999.000	-1700.000	600.000	-999.000	
8	7	-2	-10	1200.000	-1200.000	-999.000		
1700.000			600.000	-999.000	-1200.000	1100.000	-999.000	
9	-6	4	-8	1200.000	-1100.000	100.000		
1100.000			1100.000	100.000	-1100.000	1200.000	100.000	
10	9	-3	-8	1200.000	-1100.000	100.000		
1100.000			1200.000	100.000	-1200.000	1200.000	100.000	

Note that the coordinates (600,600); (600,1700); (1700,1700); (1700,600) form the framework of the triangulation and that null levels are shown as -999.0.

**Example 2**

The format of the data output by the previous example can be rearranged, in this case using three lines -

```
GENIO, ISOTEST TRIANG
001FORMAT(4I5,X,A4,/,6X,3F12.3,/,6X,3F12.3)
085,TRI1
999
FINI
```

This will produce the following output -

```
1      0      2      4
      600.000 -600.000 -999.000
      600.000 1700.000 -999.000
     -1100.000 1100.000 -999.000
2      1      5     -9
      1100.000 -600.000 -999.000
      600.000 1700.000 -999.000
     -1100.000 1200.000 -999.000
3      5      7    -10
      1100.000 -1200.000 -999.000
      1700.000 1700.000 -999.000
     -1200.000 1200.000 -999.000
4      6      0      1
      1100.000 -1100.000 -999.000
      1700.000 600.000 -999.000
     -600.000 600.000 -999.000
5      2      0      3
      1100.000 -1200.000 -999.000
      600.000 1700.000 -999.000
     -1700.000 1700.000 -999.000
6      8      4     -9
      1200.000 -1100.000 -999.000
      1700.000 600.000 -999.000
     -1100.000 1100.000 -999.000
7      3      0      8
      1200.000 -1200.000 -999.000
      1700.000 1700.000 -999.000
     1700.000 600.000 -999.000
8      7      6    -10
      1200.000 -1200.000 -999.000
      600.000 600.000 -999.000
     -1200.000 1100.000 -999.000
9     -6     -2     10
      1200.000 -1100.000 100.000
      1100.000 1100.000 100.000
     -1100.000 1200.000 100.000
10     9     -3     -8
      1200.000 -1100.000 100.000
      1100.000 1200.000 100.000
     -1200.000 1200.000 100.000
```

**Minor option 087 Section information for HECB drainage design**

DAPHNE is a drainage design program and requires as part of its input road cross section and alignment data. SAFRON is a complimentary program to DAPHNE which acts as a pre-processing program to check the section data and prepare an input file to DAPHNE. When a road has been designed using MOSS the sectional information may be linked into SAFRON using minor option 087 of major option GENIO.

Before preparing the data input for option 087 it is important to note the following:

The road cross sections from which the output file is prepared are stored in the first model, the reference string being held in the second.

The first and last points on each cross-section are assumed to be the interface points (toe of batter points).

There are eight construction line definition points used in DAPHNE (defined in the DAPHNE user manual FIG.4.1) and these must all be specified. In the minor option they are specified as string labels.

A centre line point (offset 0.0) must exist on the section (this will be the sub reference of the section string) and it must lie at or between the inner channels.

Irrespective of whether a single or dual carriageway is being considered the outer and inner channels and back of verge strings must be defined even if they are coincident. If the step points are not defined the outer channel is assumed.

A maximum of 50 cross section points are allowed.

The minor option is always defined by trios of records which are repeated if any feature string label (ie construction line definition point) changes.

The SAFRON data produced is in ASCII format and header information is all that is required to have a complete data set. It is not possible to output DAPHNE data files from MOSS.

## Input

1st Model     Contains the road sections.

2nd Model     Contains any reference strings.

### Minor option 087 - Type 1

Field 1        Road section string label for first road section.

Field 2        L.H.S. back of verge string.

Field 3        R.H.S. back of verge string.

Field 4        Leave blank for metric units.  
Code 1.0 for imperial units.

Field 5 & 6     SPRD for first point on reference string.

Field 7        Chainage interval.

Field 8 & 9     SPRD for last point on reference string.

Field 10       Leave blank for dual carriageway.  
Code 1.0 for single carriageway.

### Minor option 087 - Type 2

Field 1        L.H.S. inner channel.

Field 2        L.H.S. outer channel.

Field 3        L.H.S. step point

### Minor option 087 - Type 3

Field 1        R.H.S. inner channel.

Field 2        R.H.S. outer channel.

Field 3        R.H.S. step point

The output of the minor option is a formatted ASCII file suitable as input to SAFRON.

## Minor option 089 Full output of triangulation

This option creates a file of data describing a triangulation model created by major option TRIANGLE. All dimensions are output except for dimension 13 (group code).

The data produced by this option may be re-input to MOSS using minor option 090, 'Full input of triangulation'. In this way, triangulations may be transferred between machines which are not binary compatible.

For partial output only, see minor option 085.

### Data content

Triangulations have 33 dimensions, which are listed below:

1. Adjoining triangle on side 1
2. Adjoining triangle on side 2
3. Adjoining triangle on side 3
4. String link identifier on side 1
5. String link identifier on side 2
6. String link identifier on side 3
7. Contour level indicator
8. Contour level indicator
9. Contour level indicator
10. String label on side 1
11. String label on side 2
12. String label on side 3
13. Group code (not output)
14. Colour
15. Material
16. (Spare)
17. X coordinate for vertex 1
18. Y coordinate for vertex 1
19. Z coordinate for vertex 1
20. X coordinate for vertex 2
21. Y coordinate for vertex 2
22. Z coordinate for vertex 2
23. X coordinate for vertex 3
24. Y coordinate for vertex 3
25. Z coordinate for vertex 3
26. Tangent vector component for vertex 1 in X direction
27. Tangent vector component for vertex 1 in Y direction
28. Tangent vector component for vertex 2 in X direction
29. Tangent vector component for vertex 2 in Y direction

- 30. Tangent vector component for vertex 3 in X direction
- 31. Tangent vector component for vertex 3 in Y direction
- 32. Triangle volume in cut
- 33. Triangle volume in fill

## Data format

The default format of the data is :  
(9I8/6A4,I8/5(3D23.17/),2D23.17)

The format can be redefined using minor option 001, 'Change format'.

- ◇ *The order of the data is fixed and cannot be changed using minor option 003, 'Change order'.*

## Input

### Linemode

#### Minor option 089

Field 1        Triangulation label.

                 If blank, all triangulations in the model are output.

- ◇ *Files containing GENIO triangulation data may be very large.*

## Minor option 090    Full input of triangulation

This option reads a file of data describing a triangulation model created by minor option 089, 'Full output of triangulation'.

## Data content

The data content is described under minor option 089.

## Data format

The default format of the data is :  
(9I8/6A4,I8/5(3D23.17/),2D23.17)

The format can be redefined using minor option 001, 'Change format'.

- ◇ *The order of the data is fixed and cannot be changed using minor option 003, 'Change order'.*

## Input

### Linemode

#### Minor option 090

Field 1        Triangulation label.

Field 2        Triangulation type

                 TRIN - normal triangulation.

                 ISOS - full isopachyte triangulation.

                 QISO - partial isopachyte triangulation.

Field 4        Number of triangles

- ◇ *Files containing GENIO triangulation data may be very large.*

Example 1

The following shows triangulation input data in standard format.

◇ Only input data for three triangles is shown.

GENIO,ROAD PRELIM  
001FORMAT(9I8/6A4,I8/5(3D23.17/),2D23.17)  
090,TRI1,TRIN,,760

```

      364      229      224      -250      19      96      0      0      0
MASA      0
.17871761097488300D+04 .14482652936807690D+04 .44736569606627604D+02
.17901588590947592D+04 .14387204937174718D+04 .44806760184037188D+02
.17838354297616759D+04 .14472213314096937D+04 .44649069606627606D+02
.0000000000000000D+00 .0000000000000000D+00 .0000000000000000D+00
.0000000000000000D+00 .0000000000000000D+00 .0000000000000000D+00
.0000000000000000D+00 .0000000000000000D+00
      396      259      261      -267      36      113      0      0      0
MASA      0
.17365170952353180D+04 .15999946125209322D+04 .43613520368074369D+02
.17401298459926420D+04 .15906700716989349D+04 .43683710945483945D+02
.17332604531216550D+04 .15987123168672251D+04 .43526020368074370D+02
.0000000000000000D+00 .0000000000000000D+00 .0000000000000000D+00
.0000000000000000D+00 .0000000000000000D+00 .0000000000000000D+00
.0000000000000000D+00 .0000000000000000D+00
      636      631      640      0      -395      395      0      0      0
HRIG      0
.23470697179517028D+04 .23826098923373429D+04-.9998999999999998D+03
.18232077231842673D+04 .13547560811226515D+04-.9998999999999998D+03
.18202249738383377D+04 .13643008810859485D+04-.9998999999999998D+03
.0000000000000000D+00 .0000000000000000D+00 .0000000000000000D+00
.0000000000000000D+00 .0000000000000000D+00 .0000000000000000D+00
.0000000000000000D+00 .0000000000000000D+00
      23      197      14      2      0      78      0      0      0

```

Example 2

The following shows triangulation input data in an alternative format.

◇ Only input data for three triangles is shown.

GENIO,ROAD PRELIM  
001FORMAT(3(3I8/),6A4,I8/3(2(F12.5,1X),F12.5/),4(F12.5,1X,  
F12.5/))  
090,TRI1,TRIN,,760

```

      364      229      224
      -250      19      96
MASA      0      0      0
1787.17611 1448.26529 44.73657
1790.15886 1438.72049 44.80676
1783.83543 1447.22133 44.64907
.00000 .00000
.00000 .00000
.00000 .00000
.00000 .00000

      396      259      261
      -267      36      113
MASA      0      0      0
1736.51710 1599.99461 43.61352
1740.12985 1590.67007 43.68371
1733.26045 1598.71232 43.52602
.00000 .00000
.00000 .00000
.00000 .00000
.00000 .00000

      636      631      640
      0      -395      395
HRIG      0      0      0
2347.06972 2382.60989 -999.90000
1823.20772 1354.75608 -999.90000
1820.22497 1364.30088 -999.90000
.00000 .00000
.00000 .00000
.00000 .00000
.00000 .00000

      23      197      14
      2      0      78
      0      0      0

```

## Major option 3DDXF

3DDXF, filename

001, modelname

Major option 3DDXF provides a means of translating MOSS model information into ASCII DXF format. The option is only available in linemode. Examples of typical use are given at the end of this section.

- ◇ *Systems which require extended interpretations of DXF are expected to process the basic DXF file to satisfy their requirement.*
- ◇ *To translate DXF format to MOSS GENIO format, use the standalone program MSDXFMOSS.*

### Transfer from MOSS to DXF

Two minor options are used to transfer model information into a named DXF file, and minor option 001 defines the model to be used.

451            Transfer strings to DXF

453            Transfer triangulation to DXF

MOSS strings are represented as 3D polylines in DXF and MOSS triangles as polygon faces. Strings may be placed upon individual layers or combined on layers according to partial labels or masks. The string label defines the layer name. If no string label is given (ie transfer all strings) and MULT is specified the layer name of FULL is assigned.

Strings from different models, including triangulations may be included in the same DXF file each one forming a separate DXF block.

Before commencing a transfer from MOSS to DXF and AUTOCAD the following should be considered.

When the DXF file is loaded into AUTOCAD the display will show a very small image at one edge of the screen. To change the display so that it fills the screen use the *Display* menu to pick *Plan View*.

When the DXF file is loaded into AUTOCAD by using Inquiry it can be found that all the strings from one model are treated as being in one block, thus just the block name is reported. If manipulation of a string within one of the AUTOCAD blocks is required then the BLOCK needs to be exploded. Use the *Edit* menu to pick *Explode* and the block to be exploded.

### Minor option 451    Transfer strings to DXF

The MOSS data structure maps into DXF such that each partial string label creates a separate layer with the same label if MULT is coded; or with a separate layer and name for each string if SING is coded. The model name relates to the DXF block name. Any spaces in the model name will automatically be replaced with underscores.



## Linemode

### Minor option 451

- Field 1      String label or partial label, or blank
- Field 2      LINE to interpret strings as polylines  
                SPOT to interpret strings as discrete points  
                blank to interpret P strings as points, all others as lines.
- Field 3      SING to interpret each string to a separate layer  
                MULT to interpret all strings to a layer (default)

Field 5 & 6   SPRD start

Field 8 & 9   SPRD end

- ◇ *PSSA and point strings from SURVEY will have their layer name constructed from their label. Their fourth dimension will be stored as associated text.*
- ◇ *A string discontinuity will cause individual polystrings on the same DXF layer.*
- ◇ *Once a DXF file created using minor option 451 has been loaded into AUTOCAD it is not possible to load another DXF file created by the same option. However, DXF's created using 3DDXF option 453 or 2DDXF may be loaded into an existing AUTOCAD drawing.*

## Example

Place on separate DXF layers, as 3D polylines all strings beginning with L.

```
3DDXF,filename
001,modelname
451,L,,SING
999
```

## Minor option 453    Transfer triangulation to DXF

This option produces a DXF 3D surface for each MOSS triangle.

## Linemode

### Minor option 453

- \* Field 1      Triangulation label
- Field 2      Group code. If blank the whole triangulation is transferred.
- ◇ *A triangulation for transfer to DXF must have been generated by major option TRIANGLE. A triangulation generated by major option CONTOUR cannot be transferred.*
- ◇ *If field 2 is coded each triangle group creates a DXF layer with the same name.*
- ◇ *If field 2 is left blank the DXF layer is given the name of the triangulation.*

### Example

#### Transfer triangulation labelled TRIA

```
3DDXF,filename  
001,modelname  
453,TRIA  
999
```

## Examples

### MOSS to DXF retaining string IDs

```
3DDXF,filename
001,modelname
451,3=SING
999
```

### Output file

```
0
SECTION
2
HEADER
9
----A few default header variables go here----
0
SECTION
2
TABLES
0
TABLE
2
VPORT
70
----Here is where the viewport is set up----
0
ENDTAB
0
TABLE
2
LTYPE
70
1
0
LTYPE
2
CONTINUOUS
70
64
3
Solid line
72
65
73
0
40
0.0
0
ENDTAB
0
TABLE <---Table for layer declaration----
2
LAYER
70
4
0
```

```
LAYER
  2
0
  70
    0
  62
    7
    6
CONTINUOUS <---Shows continuous line style---
  0
LAYER
  2
C000 <---Layer name which corresponds to moss string label---
  70
    0
  62
    7
    6
CONTINUOUS
  0
LAYER
  2
C001
  70
    0
  62
    7
    6
CONTINUOUS
  0
  ----All layers are declared as above----
  0
ENDTAB
  0
TABLE
  2
STYLE
  70
    1
    0
STYLE
  2
STANDARD
  70
    0
  40
  0.0
  41
  1.0
  50
  0.0
  71
    0
  42
  3.0
  3
simplex <---Font being used. This can be changed!----
  4
SIMPLEX
  0
```

```
ENDTAB
  0
TABLE
  2
VIEW
  70
    0
    0
ENDTAB
  0
TABLE
  2
UCS <---User Co-ordinate System being used.
      This can be changed!-----
  70
    0
    0
ENDTAB
  0
ENDSEC
  0
SECTION
  2
BLOCKS
  0
BLOCK
  8
C000
  2
SIMPLE_DESIGN_GROUND <---Name of this block same asmodel name.
                        This can be changed but the block
                        being inserted should be changed to
                        match it----
  70
    64
    10
  0.0
    20
  0.0
    30
  0.0
    0
POLYLINE <---Style to which string is drawn----
  8
C000
  66
    1
  70
    8
    0
VERTEX
  8
C000 <---Layer/string being drawn----
  10
    501513.4416256 <---X----
  20
    111233.6254451 <---Y----
  30
    46.4370000 <---Z----
  70
```

```

    32
    0
  VERTEX
    8
  C000
    10
      501504.2652048
    20
      111229.6512879
    30
      47.1880000
    70
      32
    0
    ----All vertices on layer done as above----
  SEQEND <---Shows end of string has been reached----
    8
  C000
    0
  POLYLINE
    8
  C001
    66
      1
    70
      8
    0
  VERTEX
    8
  C001
    10
      501514.5400568
    20
      111231.0716541
    30
      46.5170000
    70
      32
    0
    ----And so on for all strings in the model----
  SEQEND
    8
  V005
    0
  ENDBLK <---Shows that all strings required have been translated
          and so the block is closed----
    8
  V005
    0
  ENDSEC
    0
  SECTION
    2
  ENTITIES
    0
  INSERT <---The block is inserted onto the screen----
    8
  C000 <---Layer onto which it is inserted----
    2
  SIMPLE_DESIGN_GROUND <---Block being inserted----

```

```

10
0.0 <---X position of insertion----
20
0.0 <---Y position of insertion----
30
0.0 <---Z position of insertion----
0
ENDSEC
0
EOF <---End of file marker----

```

### MOSS to DXF multiple models, retaining string IDs

```

3DDXF,filename
001,modelname
451,3=SING
001,next modelname
451,3=SING
etc
999

```

### Output file

```

0
SECTION
2
HEADER
9
<----Header section----
0
ENDSEC
0
SECTION
2
TABLES
0
TABLE
2
VPORT
70
<----Viewport table----
0
ENDTAB
0
TABLE
2
LTYPE
70
<----Line style table----
0
ENDTAB
0
TABLE
2
LAYER
70
<----Layer declaration table----
0
ENDTAB
0

```

```

TABLE
  2
STYLE
  70
    <----Font table----
    0
ENDTAB
  0
TABLE
  2
VIEW
  70
    0
    0
ENDTAB
  0
TABLE
  2
    <----Co-ordinate system table----
    0
ENDTAB
  0
ENDSEC
  0
SECTION
  2
BLOCKS <----Blocks section----
  0
BLOCK
  8
0000
  2
THORNBROUGH_GROUND_MODEL <----First translated model----
  70
    64
    10
0.0 <----X position of creation----
  20
0.0 <----Y position of creation----
  30
0.0 <----Z position of creation----
  0
POLYLINE
  8
0000
  66
    1
  70
    8
    0
VERTEX
  8
0000
  10
    3114.1549401
  20
    29025.2164509
  30
    131.0000000
  70

```



```

      32
      0
    VERTEX
      8
    0000
      10
          3103.4403231
      20
          29033.5721523
      30
          131.0000000
      70
      32
      0
          <----And so on as above----
    SEQEND
      8
    0000
      0
    POLYLINE
      8
    0001
      66
          1
      70
          8
      0
    VERTEX
      8
    0001
      10
          2832.1664804
      20
          29591.3701385
      30
          130.0000000
      70
      32
      0
    VERTEX
      8
    0001
      10
          2836.6558899
      20
          29578.6454650
      30
          130.0000000
      70
      32
      0
          <----And so on----
    SEQEND
      8
    000N
      0
    ENDBLK <----End of this block marker----
      8
    000N
      0

```

```
BLOCK <----Another block is coming----  
  8  
C000  
  2  
SIMPLE_DESIGN_GROUND <----Next translated model---  
  70  
    64  
  10  
  0.0  
  20  
  0.0  
  30  
  0.0  
  0  
POLYLINE  
  8  
C000  
  66  
    1  
  70  
    8  
  0  
VERTEX  
  8  
C000  
  10  
    501513.4416256  
  20  
    111233.6254451  
  30  
    46.4370000  
  70  
    32  
  0  
    <----And so on----  
SEQEND  
  8  
V005  
  0  
ENDBLK <----End of block marker----  
  8  
V005  
  0  
ENDSEC <----End of blocks section marker----  
  0  
SECTION  
  2  
ENTITIES  
  0  
INSERT  
  8  
0000  
  2  
THORNBROUGH_GROUND_MODEL <----Model inserted on screen----  
  10  
  0.0  
  20  
  0.0  
  30  
  0.0
```

```
0
INSERT
8
C000
2
SIMPLE_DESIGN_GROUND <----Model inserted on screen----
10
0.0
20
0.0
30
0.0
0
ENDSEC <----End of entities section----
0
EOF
```

### MOSS to DXF string IDs not relevant

```
3DDXF,filename
001,modelname
451
999
```

◇ *All string are placed on one DXF layer named FULL.*

### Output file

```
0
SECTION
2
HEADER
9
-----
0
ENDSEC
0
SECTION
2
TABLES
0
TABLE
2
VPORT
70
-----
0
ENDTAB
0
TABLE
2
LTYPE
70
-----
0
ENDTAB
0
TABLE
2
LAYER
70
```

```

    4
  0
LAYER
  2
0
  70
    0
  62
    7
  6
CONTINUOUS
  0
LAYER
  2
FULL <----Shows that only one layer is declared 'FULL'----
  70
    0
  62
    7
  6
CONTINUOUS
  0
ENDTAB
  0
TABLE
  2
STYLE
  70
-----
  0
ENDTAB
  0
TABLE
  2
-----
  0
ENDTAB
  0
TABLE
  2
-----
  0
ENDTAB
  0
ENDSEC
  0
SECTION
  2
BLOCKS
  0
BLOCK
  8
FULL <----Full is the layer the model is created on----
  2
SIMPLE_DESIGN_ROAD
  70
    64
  10
0.0
  20

```

```
0.0
 30
0.0
 0
POLYLINE
 8
FULL <----Layer/string label is 'FULL'----
 66
   1
 70
   8
   0
VERTEX
 8
FULL
 10
   501299.7974595
 20
   111156.4905461
 30
   63.7105456
 70
   32
   0
-----
SEQEND
 8
FULL
 0
POLYLINE
 8
FULL <----Layer/string label again is 'FULL'----
 66
   1
 70
   8
   0
VERTEX
 8
FULL
 10
   501509.4777625
 20
   111224.1848987
 30
   46.9688179
 70
   32
   0
-----
SEQEND
 8
FULL
 0
POLYLINE
 8
FULL <----All layer/string labels are 'FULL'----
 66
   1
 70
```

```

      8
    0
  VERTEX
    8
  FULL
    10
    501273.6699829
    20
    111179.9852801
    30
    66.3357916
    70
    32
    0
  -----
    0
  SEQEND
    8
  FULL
    0
  ENDBLK
    8
  FULL
    0
  ENDSEC
    0
  SECTION
    2
  ENTITIES
    0
  INSERT
    8
  FULL <----Model is inserted on layer 'FULL'----
    2
  SIMPLE_DESIGN_ROAD
    10
  0.0
    20
  0.0
    30
  0.0
    0
  ENDSEC
    0
  EOF

```

**MOSS to DXF transfer only F strings**

```

3DDXF,filename
001,modelname
451,F,3=SING
999

```

**Output file**

```

0
SECTION
2
HEADER
9

```

-----

0	
ENDSEC	
0	
SECTION	
2	
TABLES	
0	
TABLE	
2	
VPORT	
70	
-----	
0	
ENDTAB	
0	
TABLE	
2	
LTYPE	
70	
-----	
0	
ENDTAB	
0	
TABLE	
2	
LAYER	
70	
4	
0	
LAYER	
2	
0	
70	
0	
62	0
7	
6	
CONTINUOUS	
0	
LAYER	
2	
F000	
70	
0	
62	0
7	
6	
CONTINUOUS	
0	
LAYER	
2	
F001	
70	
0	
62	0
7	
6	
CONTINUOUS	
0	

```

LAYER
  2
F002
  70
    0
  62
    7
    6
CONTINUOUS
  0
LAYER
  2
F003
  70
    0
  62
    7
    6
-----Above shows that only the F strings
-----have been declared as layers
ENDTAB
  0
TABLE
  2
STYLE
  70
-----
  0
ENDTAB
  0
TABLE
  2
VIEW
  70
    0
    0
ENDTAB
  0
TABLE
  2
-----
  0
ENDTAB
  0
ENDSEC
  0
SECTION
  2
BLOCKS
  0
BLOCK
  8
F000
  2
SIMPLE_DESIGN_GROUND
  70
    64
    10
  0.0
  20

```



0.0  
30  
0.0  
0  
POLYLINE  
8  
F000  
66  
1  
70  
8  
0  
VERTEX  
8  
F000  
10  
501220.2112776  
20  
111217.1305785  
30  
72.8200000  
70  
32  
0  
VERTEX  
8  
F000  
10  
501228.8795403  
20  
111221.2689713  
30  
72.5000000  
70  
32  
0  
-----  
SEQEND  
8  
F000  
0  
POLYLINE  
8  
F001  
66  
1  
70  
8  
0  
VERTEX  
8  
F001  
10  
501213.5339746  
20  
111122.9974646  
30  
65.3960000  
70  
32

```
0
VERTEX
8
F001
10
    501223.5075350
20
    111124.0398249
30
    64.5360000
70
    32
0
SEQEND
8
F001
0
-----Again above shows that only the F strings
-----have been translated into polylines
ENDBLK
8
F009
0
ENDSEC
0
SECTION
2
ENTITIES
0
INSERT
8
F000
2
SIMPLE_DESIGN_GROUND
10
0.0
20
0.0
30
0.0
0
ENDSEC
0
EOF
```

### **MOSS to DXF transfer only F, LO and D strings**

```
3DDXF,filename
001,modelname
019,F,4=1
019,LO,4=1
019,D,4=1
019,,4=-1
451,3=SING
999
```

### **Output file**

```
0
SECTION
2
```

HEADER  
9  
-----  
0  
ENDSEC  
0  
SECTION  
2  
TABLES  
0  
TABLE  
2  
VPORT  
70  
-----  
0  
ENDTAB  
0  
TABLE  
2  
LTYPE  
70  
-----  
0  
ENDTAB  
0  
TABLE  
2  
LAYER  
70  
4  
0  
LAYER  
2  
0  
70  
0  
62  
7  
6  
CONTINUOUS  
0  
LAYER  
2  
D000  
70  
0  
62  
7  
6  
CONTINUOUS  
0  
LAYER  
2  
D001  
70  
0  
62  
7  
6

CONTINUOUS  
0  
LAYER  
2  
D002  
70  
0  
62  
7  
6  
CONTINUOUS  
0  
LAYER  
2  
F000  
70  
0  
62  
7  
6  
CONTINUOUS  
0  
LAYER  
2  
F001  
70  
0  
62  
7  
6  
CONTINUOUS  
0  
LAYER  
2  
F002  
70  
0  
62  
7  
6  
CONTINUOUS  
0  
LAYER  
2  
L000  
70  
0  
62  
7  
6  
CONTINUOUS  
0  
LAYER  
2  
L001  
70  
0  
62  
7  
6

CONTINUOUS  
0  
LAYER  
2  
L002  
70  
0  
62  
7  
6  
CONTINUOUS  
0  
LAYER  
2  
L00F  
70  
0  
62  
7  
6  
CONTINUOUS  
0  
ENDTAB  
0  
TABLE  
2  
STYLE  
70  
-----Above shows how just the masked  
-----strings have been translated and  
-----written to separate layers  
0  
ENDTAB  
0  
TABLE  
2  
VIEW  
70  
0  
0  
ENDTAB  
0  
TABLE  
2  
-----  
0  
ENDTAB  
0  
ENDSEC  
0  
SECTION  
2  
BLOCKS  
0  
BLOCK  
8  
D000  
2  
SIMPLE\_DESIGN\_GROUND  
70

64

10

0.0

20

0.0

30

0.0

0

POLYLINE

8

D000

66

1

70

8

0

VERTEX

8

D000

10

501508.4081965

20

111181.2575800

30

40.9000000

70

32

-----

0

SEQEND

8

D000

0

ENDBLK

8

LOOF

0

ENDSEC

0

SECTION

2

ENTITIES

0

INSERT

8

D000

2

SIMPLE\_DESIGN\_GROUND

10

0.0

20

0.0

30

0.0

0

ENDSEC

0

EOF

# External programs

## Introduction

In its early versions MOSS was essentially one program. Then PLOTTER and DISPLAY were introduced as standalone programs, but were closely integrated with MOSS. There are now other programs, some developed by other software suppliers, which form part of the overall MOSS solution.

First this chapter introduces these external programs and then gives brief instructions for running them. If all you need is an overview, just read this *Introduction*. On the other hand, if you require full documentation for the programs this will usually be available from the program supplier.

The programs covered are:

### *Data Collection*

- Site Measurement Module
- MSSMTRANS
- MSOSPP
- ORDSDRAW

### *Data Conversion*

- MSMODCNV
- MSDPFCNV

### *Drainage Design*

- WALLRUS
- MICRORAT

### *Graphics*

- MSPLOTTER
- MSMIFILE
- MS2DDXF
- MSDXFMOSS
- MSMINT
- MSDAMS

### *EPIC*

- MSSHOW

### *Documentation*

- MSDOCUMENT

### *UPM*

- MSCRMENU

## Data Collection

### Site Measurement Module

Current survey equipment already provides full prompting and can automatically output pre-formatted MOSS minor options. The Site Measurement Module has been developed from Autograd for use with a proprietary device (the Husky Hunter portable computer) to link any electronic survey instrument automatically into MOSS.

The survey instrument/Husky/MOSS system generates full prompting for traversing and detail survey observations, and enables automated setting out.

### MSSMTRANS

The data collection methods for the Site Measurement Module are described in the documentation for the module, but the data must be transferred from the Husky Hunter to the workstation on which MOSS is running. MOSS supplies program MSSMTRANS (Site Measurement TRANSfer program) for this.

### MSOSPP

The Ordnance Survey are collecting digital data for the whole of the UK. They store this data on magnetic disk and either plot it directly to produce their own maps, or supply it to others on magnetic tape. This data can be converted to MOSS GENIO format and stored as a MOSS model, from where the full range of MOSS facilities can be brought to bear upon it.

Program MSOSPP performs the conversion from the Ordnance Survey formats known as DMC (Digital Mapping for Customers), OSTF (Ordnance Survey Transfer Format), or NTF (National Transfer Format) to MOSS GENIO format.

### ORDSDRAW

This is a macro used for drawing OS data that has been transformed into MOSS.

## Data Conversion Drainage design

### MSMODCNV

MSMODCNV is a stand alone program which enables model file data to be converted for transfer from the host platform to a PC platform.



## MSDPFCNV

MSDPFCNV is a stand alone program which enables Draw Picture File (DPF) data to be converted for transfer from the host platform to a PC platform.

## Drainage design

### WALLRUS

Within the UK, Hydraulics Research Ltd is a recognised centre of expertise in drainage analysis. Hydraulics Research has developed a number of programs for storm sewer analysis and has collected these into a package called WALLRUS. WALLRUS is implemented within MOSS under licence from Hydraulics Research.

WALLRUS can handle a wide range of climatic types, including the standard UK rainfall run-off and flood frequency models. It also incorporates features for spatially-varied rainfall, free surface backwater effects, and sediment depths.

### MICRORAT

MICRORAT is a component of WALLRUS, but is also offered as an independent program because of its wide usage. It is used to design pipe or channel sizes and gradients, using a modified version of the Rational Method.

## Graphics

MOSS drawing information is held on a file known as the DRAW Picture File, or DPF for short. The DPF contains structured data which associates attributes such as linestyles, colours and scales with their corresponding model information on the MOSS model file. The DPF contains all the information necessary for a picture to be drawn on a targeted graphics device, but is nevertheless independent of all graphics terminals or workstations.

### MSPLOTTER

You can generate a hard copy of a MOSS drawing from the DPF if you have a program to drive your particular plotter. Such programs are called plotter drivers. The plotter drivers that have been developed by MSL take advantage of the functionality of individual plotters through the standalone MSPLOTTER procedure.

MSPLOTTER (and the graphics preview program MSDISPLAY) can be run either from within MOSS, or external to MOSS as a standalone program.

## MSDISPLAY

MSDISPLAY allows you to view a DPF. Facilities are provided to change sheet, zoom and window the displayed picture.

## MSMIFILE

MSMIFILE is a program which produces a MOSS Intermediate File, sometimes also called the MIF. It is used to transfer graphics information held on the DPF to complementary graphics systems. The program may be run either from within MOSS as a major option, or externally as a standalone program.

A number of interfaces between MSMIFILE and other systems now exist, validated by MOSS Systems. Your MOSS supplier can provide a list of these.

## MS2DDXF

MS2DDXF is a program which produces a 2D DXF format file. It is used to transfer graphic information held on the DPF to complementary systems such as AutoCAD. It is supplied and supported as a MOSS product.

## MSDXFMOSS

MSDXFMOSS produces a MOSS file in GENIO format from a 3D DXF file.

## MSMINT

MSMINT produces a MOSS file in GENIO format from Intergraph SIF format, and vice-versa.

## MSDAMS

MSDAMS produces a MOSS file in GENIO format from a DA format 001 file.

## EPIC

## MSSHOW

MSSHOW is a program which displays stored CGAL frames. They can be shown one at a time or replayed in a sequence without having to use the main CGAL program.

## Documentation

### MSDOCUMENT

MSDOCUMENT provides access to the online document set.

## UPM

MSCRMENU provides users with a UPM development licence the ability to construct menus for UPMs to be run in MOSS IGmode.

## Site Measurement Module

Operating details for the Site Measurement Module are in the Site Measurement Instruction Manual produced by:

Optimal Software Limited

Highbank

Halton Street

Hyde

Cheshire

## Program MSSMTRANS

MSSMTRANS transfers site measurement data from the Husky Hunter portable computer to the computer on which you're running MOSS (the host computer). It is invoked as a standalone program on your host computer.

To transfer data, you run the Input/Output module on the Husky at the same time as running MSSMTRANS on the host.

MSSMTRANS displays a sequence of prompts to guide you.

The Input/Output module is part of the Site Measurement Module which is also sometimes known as Autograd. For details on how to use it, see the Site Measurement Instruction Manual.

Versions of this program exist for each of the host computers supporting MOSS. There are some minor differences between the operation of these versions, but the functionality will be the same.

You will need a cable to connect the Husky to your host computer. The pin connections and other details are described in your *MOSS Installation Guide*.

### Host setup

On the host computer, enter the command: *MSSMTRANS*

You will then get the following series of prompts, which you should answer as indicated (prompts may vary slightly, depending on the host computer):

```
Do you want to send data to the data recorder, or  
receive data? [S/R]
```

```
 Type S or R
```

Please enter name of file to be sent to/received from the data recorder

Reply with a file name. If you are receiving data from the recorder and omit a file name and suffix, MSSMTRANS will create a file called <file name>.INP. If you supply a filename suffix (for example .FIL) this will be used.

Please enter line to be used for transfer, eg  
1,2,3

Type the line to which the Husky is connected

Please enter baud rate of terminal line

Type any of:

300, 600, 1200, 2400, 4800, 9600 (we recommend 4800)

Please connect data recorder and set communications parameters as follows:

(This is followed by a list of communications settings for the Husky)

Before setting the Husky parameters check the following (these checks are described in detail in the documentation for the Husky):

- that a suitable battery power level or mains supply is available for the Husky data collector throughout data transfer
- that you have sufficient disk space available for the down-loaded data
- that you have selected the correct job number and that you have entered revised administration details where necessary
- that the INPUT/OUTPUT module has been selected from the Site Measurement Module main menu.

## Husky setup

To setup the Husky Hunter:

- select Communications
- select Communications Parameters
- select Computer

You will be presented with five parameters:

Baud rate    Parity        Protocol        Endline        Echo

Use the up/down and left/right arrow keys to select each parameter value to match those shown on the host computer.

To confirm the parameter values as highlighted, select ESC.

Select ESC twice to return to the Input/Output menu, via the Communications menu.

Select System I/O, which will give you two alternatives:

- Input to Autograd (this is the Site Measurement Module)
- Output to MOSS

### **Input to Autograd**

The menu offers a choice of *Control data* or *Design data*.

Select the one which corresponds to the data to be sent by MSSMTRANS.

Select enter to load data

If a DESIGN/CONTROL file is already stored within the current job a warning will be given.

“Warning! Existing CONTROL/DETAIL will be overwritten ENTER to confirm”.

Select ENTER - the Husky is now ready to receive data.

Select return on the computer keyboard to begin the data transfer.

### **Output to MOSS**

The menu offers a choice of *Traverse* or *Detail*. Select one of these. The Husky will then display a mean reduced level which has been calculated from the level values used in the job. You may press *Enter* to accept this reduced level, or type in an alternative value followed by *Enter*.

If you selected *Traverse*, you are then asked to input the tolerances within which the MOSS traverse calculations should operate. These are:

- Linear accuracy expressed as ratio (ie 10,000)
- Angular accuracy expressed in seconds (ie 10)

Select the adjustment method for the traverse : Bowditch, Unaltered or Birds. Select one with the cursor and press Enter. The Husky is now ready to send Traverse or Detail data. Select Return on the computer keyboard to prepare MSSMTRANS to receive data, then Enter on the Husky keyboard. The data will now be sent.

◇ The traverse angular misclosure value transmitted will not be processed in MOSS.

### **Completion of data transfer**

When the data transfer is complete press function key F1 and return to the computer command prompt. (This is for the Apollo; other computers might require other key sequences).

If further data is to be transmitted in either direction re-enter the command MSSMTRANS and re-specify the requested transmission data.

Repeat the process for data transfer as required.

Husky Computers Ltd  
345 Foleshill Road  
Coventry CV6 5RW  
UK  
Tel 01203 668181

## Program MSOSPP

The MOSS program MSOSPP translates vector maps from the Ordnance Survey into MOSS.

The Ordnance Survey (OS) are collecting digital data for the UK and hope to substantially complete the program by the mid 1990's. For many urban areas this is already the case.

The OS stores the data on computer disk. It either produces its own maps directly from this data using precision plotters, or supplies the data to others on magnetic tape.

The MOSS program MSOSPP converts the OS data into MOSS model data (GENIO format) for input to the MOSS modelfile. Once in the MOSS modelfile the full range of MOSS facilities for analysis and design can be brought to bear upon the data.

Table 14 -1 shows the map formats supported by OSPP.

Scale	Data	Format	Notes
1 : 1250 & 1 : 2500	Unstructured maps OS88	DMC	No longer available
1 : 1250 & 1 : 2500	Unstructured maps OS88	OSTF	No longer available
1 : 1250, 1:2500 & 1 : 10000	Unstructured maps Landline.93 & 93+	NTF	Up to V2.0
<u>1 : 10000</u>	<u>Land-Form profile Contours &amp; DTM</u>	<u>NTF</u>	<u>Up to V2.0</u>
1 : 50 000	Topographic contours	NTF	Up to V2.0
1 : 50 000	Topographic square grid (DTM)	NTF	Up to V2.0
1 : 250 000	Unstructured maps	NTF	Up to V2.0
1 : 625 000	Unstructured	NTF	Up to V2.0

	maps		
--	------	--	--

**Table 14 -1 OSPP map formats**

Macro ORSDRAW is provided to draw large scale map data quickly and easily.

The Ordnance Survey supply data as 0.5" magnetic tape, tar format unix cartridge and PC format floppy disk.

- ◇ *MSL have found that when data is requested from the Ordnance Survey on 0.5" magnetic tape, fixed length records must be specified.*
- ◇ *Documentation for these formats is available from Ordnance Survey.*

### How MSOSPP works

During processing, MSOSPP creates an individual GENIO data set for each map. One OS data file creates one GENIO output file but this may contain several datasets, one for each map.

In the OS data the string points are stored as local co-ordinates, but MSOSPP converts them to National Grid Coordinates, and stores them as three pairs of co-ordinates per record, which is the standard GENIO format for 3D information.

Text strings are processed similarly, and the points are stored in the correct text string format, carrying orientation and size of text.

### Formats

For details of the OS data formats please refer to the appropriate documentation available from the OS.

- ◇ *The Ordnance Survey also supply a program **NGCOORD**. This converts the DXF file from a local coordinate system to the OS National Grid coordinate system. A new file is created in the process.*

*The resulting DXF file can then be run through DXFMOSS to produce a GENIO file for use in MOSS. Any queries about NGCOORD should be directed to the Ordnance Survey.*

## String labelling

The following tables show the partial string labels allocated by default for each feature code:

Table 14 -2 NTF V1.1/V2.0 feature codes (large scale maps)

Table 14 -3 NTF V1.1/V2.0 topographical feature codes (1:50 000)

Table 14 -4 NTF V1.1 feature codes (small scale 1:250 000 and 1:625 000)

Table 14 -5 NTF V2.0 feature codes (small scale 1:250 000 and 1:625 000)

In addition to the partial string label, a string subreference is allocated for each feature code so that each feature can be uniquely identified once it has been converted to a MOSS string.

## Feature code data file

The partial string labels allocated for each feature code are stored in a feature code data file 'os1tab.dat'. You may modify this file to customise the allocation to your own requirements, or create a copy in your local directory for your own use.

In order for MSOSPP to use the correct feature codes file, you should modify the parameter OSLABE in your switch file so that it points to the correct location and file.

The feature code data file is an ASCII file with each record containing the following fields:

### **Field 1 - columns 1 to 7**

OS feature code name. The feature code must be left justified.

### **Field 2 - columns 15 to 18**

String label (partial or full). The label must be left justified.

A full label can be used if, for example, a point string is required.

### **Field 3 - columns 25 to 28**

String subreference. The subreference must be left justified.

### **Field 4 - columns 35 onwards**

Description of feature code.

Comments can be placed in the data file. Comment lines should start with an asterisk (\*) and are ignored by MSOSPP.

To cater for feature codes which are not in the list but are found in the OS data set, Field 1 can be coded with "NULL". The partial string label given is then used to convert any strings found which do not have a feature code entry in the data file.





If there is no "NULL" record in the data file, feature codes which do not have an entry are ignored. These feature codes are recorded in the log file.

<b>Feature code</b>	<b>Partial string label</b>	<b>Sub reference</b>	<b>Description</b>
0001	0	OUTL	Building Outline:
0030	0	GENL	General Line Detail:
0059	0	WATR	Water Feature:
0072	0	MLWM	Mean Low Water:
0075	0	CONT	Contour:
0004	2	BPEC	Building Pecks:
0021	2	RPEC	Pecked Road Metalling:
0032	2	GPEC	General Peck Detail:
0007	4	PBON	Parish/Community Boundary:
0008	5	DBON	District/LB Boundary:
0009	6	CBON	County/Region/Island Boundary:
0010	7	EBON	Electoral Boundary:
0079	7	PBON	Parliamentary Boundary:
0014	8	NRAL	Narrow Gauge Railway:
0015	9	SRAL	Standard Gauge Railway:
0052	9	MLIN	Minor Line Detail:
0033	A	UPEC	Underground Peck Detail:
0043	B	OPEC	Overhead Peck Detail:
0071	D	MHWM	Mean High Water:
0036	E	VEGL	Vegetation/Landform Limit:
0098	E	RLIN	Centre Line of Road:
0025	G	TRIG	Trig Point:
0026	H	BENC	Bench Mark:
0027	I	SPOT	Spot Height:
0057	P	PTFE	Point Feature:
0011	I	BONP	Boundary Post/Stone:
0013	S	BONM	Boundary Mereing Symbol:
0321	T	BSEE	Building Seed:
0323	T	GSEE	Glasshouse Seed:
0069	Y	FLOW	Flow Arrow:
0049	Z	PYLN	Pylon:
1000	*0		Road Names & Numbers:
1005	*2		Boundary & Administrative Information:
1006	*4		House Numbers & Building Names:
1007	*6		UNKNOWN
1009	*8		Miscellaneous Names:
1010	*A		Water Feature Names:
1013	*C		Land Parcel Numbers:

0199	T	NONE	UNKNOWN
0037	J	TBGP	Telephone call box - GPO
0038	K	TBAA	Telephone call box - AA
0039	L	TBRA	Telephone call box - RAC
0040	M	TPGP	Telephone post/pillar - GPO
0041	N	TPAA	Telephone post/pillar - AA
0042	O	TPRA	Telephone post/pillar -RAC
0048	Z	PYLN	Pylon - surveyed
0067	Y	FLOL	Flow Arrow - large
0068	Y	FLOM	Flow Arrow - medium
0082	Q	CIRO	Objects shown by circle
0058	Q	CIRO	Objects shown by circle
0035	E	VLIM	Vegetation/Landform Limit (supp):L
0372	PC	POSN	Positioned Coniferous Tree:
0373	PC	NOPO	Positioned Non-Coniferous Tree:
0374	E	SLOP	Top of Slope:L
0375	E	CLIF	Top of Cliff:L
0376	E	BOTT	Bottom of Slope or Cliff:L
0377	PB	BOUL	Boulders:
0378	PB	SCBO	Boulders Scattered:
0379	PC	CONF	Coniferous Trees:
0380	PC	CONS	Coniferous Trees Scattered:
0381	PO	COPP	Coppice/Osiers:
0382	PM	MARS	Marsh/Saltmarsh/Reeds:
0384	PD	DECD	NON-Coniferous Trees:
0385	PD	DECS	NON-Coniferous Trees Scattered:
0386	PD	ORCH	Orchard:
0387	PH	HEAT	Heath:
0388	PR	ROCK	Rock:
0389	PR	ROCS	Rock Scattered:
0390	PG	RGRA	Rough Grassland:
0392	PG	SCRU	Scrub:
0395	PU	COMM	Upper Level of Communication:
0396	PL	CLIF	Cliff:
0397	PK	SLOP	Slope:
0400	PW	WATR	Water:
1210	PE	SCRE	Scree:
1211	PB	PBOU	Positioned Boulder:
1212	R	RIDG	Ridge/Rock Line:

**Table 14 -2 NTF V1.1/V2.0 feature codes (large scale maps)**

<b>Feature code</b>	<b>Partial string label</b>	<b>Sub reference</b>	<b>Description</b>
0200	P		Spotheights:
0201	C		Contours:
0202	L		Lakes:
0203	B		Breaklines:
0204	E		Coastlines:
0205	2		Ridgelines:
0207	F		Formlines:

**Table 14 -3 NTF V1.1/V2.0 topographical feature codes (1:50 000)**

<b>Feature code</b>	<b>Partial string label</b>	<b>Sub reference</b>	<b>Description</b>
E12064L	0	MIRV	Minor River
E12096L	0	MARV	Main River, Source
E12128L	0	SDRV	Secondary River, Source
E12160L	0	MMRV	Main River, Middle
E12256L	0	SLRV	Secondary River, Lower
E12288L	0	MLRV	Main River, Lower
E13008L	0	CANO	Canal, over other Feature
E13016L	0	CANT	Canal Tunnel
G21000L	0	FSOM	Foreshore, Other, Margin
G21512L	0	FSSM	Foreshore, Sand, Margin
E12032L	0	RIVR	Main River
E13000L	0	CANL	Canal
E20000L	0	LAKE	Lake, Margin
E20512L	0	RESV	Reservoir, Margin
E10512L	0	CLWM	Coast, LWM
R11000L	0	CMAN	Coast, Manmade
OVER	1		OVERFLOW FROM LABEL 0
A16000L	2	BOAT	Ferry
G12008L	3	SURB	Small Urban Area, Margin
G12000L	4	LURB	Large Urban Area, Margin
S12000L	5	DBON	District Boundaries
S12128L	5	DBOC	District Boundary, Cartographic
S12256L	5	DBOS	District Boundary, Seaward Extension
S11000L	6	CBON	County Boundaries
S11064L	6	CBLW	County Boundary, LWM
S11128L	6	CBOC	County Boundary, Cartographic
S11256L	6	CBOS	County Boundary, Seaward Extension
S10000L	7	NBON	National Boundaries
S10256L	7	NBOS	National Boundary, Seaward Extension
C12256L	8	NRAO	Railway, Narrow Gauge, over other Feature
C12000L	8	NRAL	Railway, Narrow Gauge
C10256L	9	SRAO	Railway, Standard Gauge over other Feature
C10000L	9	SRAL	Railway, Standard Gauge
C10512L	9	TRAL	Railway, Tunnel
B14000P	B	TOLL	Toll
K10000P	B	BRID	Bridge
E10000L	D	CHWM	Coast, Natural, HWM
A10776L	E	MOUC	Motorway - Under Construction

A10784L	E	MOOF	Motorway, over other Feature
A10768L	E	MWAY	Motorway
A10800L	F	RTNL	Road Tunnel
A11008L	F	SCAR	A Road, Single Carriageway under Const.
A11016L	F	SOAR	A Road, S Carriageway over other Feature
A11032L	F	STAR	A Road, Single Carriageway Tunnel
A11064L	F	NWAR	A Road, Narrow
A11080L	F	NOAR	A Road, Narrow, over other Feature
A11256L	F	DUAR	A Road, Dual Carriageway
A11264L	F	DCAR	A Road, D Carriageway under Const.
A11272L	F	DOAR	A Road, D Carriageway over other Feature
A11000L	F	SNAR	A Road, Single Carriageway
A11512L	G	SNPR	Primary Route, Single Carriageway
A11520L	G	SCPR	Primary Route, S Carriageway under Const.
A11528L	G	SOPR	Primary Route, S C'way over other Feature
A11544L	G	STPR	Primary Route, Single Carriageway Tunnel
A11576L	G	NWPR	Primary Route, Narrow
A11592L	G	NOPR	Primary Route, Narrow over other Feature
A11768L	G	DUPR	Primary Route, Dual Carriageway
A11776L	G	DCPR	Primary Route, D Carriageway under Const.
A11784L	G	DOPR	Primary Route, D C'way over other Feature
A12016L	H	SOBR	B Road, S Carriageway over other Feature
A12064L	H	NWBR	B Road, Narrow
A12080L	H	NOBR	B Road, Narrow, over other Feature
A12256L	H	DUBR	B Road, Dual Carriageway
A12272L	H	DOBR	B Road, D Carriageway over other Feature
A12000L	H	SNBR	B Road, Single Carriageway
A13016L	I	OFCR	Minor/Other Road, over other Feature
A13032L	I	TNCR	Minor/Other Road, Tunnel
A13000L	I	CROD	Minor/Other Road
P12000L	J	LPAT	Long Distance Footpath
D10000P	L	RSTN	Railway Station
H10512L	N	NPAR	National Park Boundary
H11064P	P0	ISEE	Small Island/Island Seed
I10000P	P0	ASEE	Geographical Area Seed
I11256P	P0	HSEE	Headland Seed
I12064P	P0	GSEE	Island Group Seed
I12128P	P0	SSEE	Sea Seed
K12000P	P0	GRAD	Gradient, 1 in 7 or Steeper
H11032P	P0	ROCK	Rock
N10000P	P0	UNOD	Unspecified Node

E20000P	P1	LSEE	Lake, Seed
E20512P	P1	RSEE	Reservoir, Seed
G21000P	P1	FOSE	Foreshore, Other, Seed
G21512P	P1	FSSE	Foreshore, Sand, Seed
G12008P	P3	SUSE	Small Urban Area, Seed
G12000P	P4	LUSE	Large Urban Area, Seed
S12000P	P5	DSEE	District Seed
S12512P	P5	DDSE	District Seed, detached
S11000P	P6	CSEE	County Seed
S11512P	P6	CDSE	County Seed, detached
S10000P	P7	NSEE	National Seed
D11000P	P9	LEVL	Level Crossing
B10532P	PE	MJUC	Motorway Junction, Under Construction
B10536P	PE	MJLA	Motorway Junction, Limited Access
B11000P	PE	MULJ	Multilevel Junction
B10528P	PE	MJUN	Motorway Junction
H10512P	PN	NSEE	National Park Seed
T10000P	PV	BATL	Battlefield
T11000P	PV	FORT	Hill Fort
G10000P	PW	WSEE	Woodland, Seed
J10000P	QT	TONP	Town, not Primary Route Destination
J10256P	QT	LTNP	Large Town, not Primary Route Destination
J10512P	QT	TOWN	Town, Primary Route Destination
J12000P	QV	VINP	Village, not Primary Route Destination
J12064P	QV	SETL	Small Settlement
J12512P	QV	VILL	Village, Primary Route Destination
B12018P	R	RDPR	Roundabout, Primary Route d/c
B12256P	R	RSAR	Roundabout, A Road s/c
B12258P	R	RDAR	Roundabout, A Road d/c
B12272P	R	RSAR	Roundabout, Primary Route s/c
B12128P	R	RSBR	Roundabout, B Road s/c
B12032P	R	RDMR	Roundabout, Minor/other Road
B12130P	R	RDBR	Roundabout, B Road d/c
J13512P	S	CITY	City, Primary Route Destination
Q10000P	T	AIRN	Civil Aerodrome (No Customs facilities)
Q10001P	T	AIRC	Civil Aerodrome (Customs facilities)
Q10512P	T	HELI	Heliport
B13256P	UF	SRVA	A Road Services
B13520P	UF	SLVA	A Road Services, Limited Access
B13528P	UE	SRVM	Motorway Services
B13532P	UE	SUVM	Motorway Services, Under Construction

B13536P	UE	SLVM	Motorway Services, Limited Access
T13008L	V	ROME	Roman Road
T14000L	V	ANTQ	Antiquity Detail, Linear
G10000L	W	WOOD	Woodland, Margin
Q18000P	X	WMIL	Windmill
Q15032P	X	MAST	Radio Mast
Q16008P	Z	LTSP	Lightship
Q16002P	Z	LTSD	Lighthouse (disused)
Q16016P	Z	LTHS	Lighthouse (in use)
J14000P	PT	NAME	Cartographic name, settlement
0000	*		TEXT [RECORD 11] - FC entry needed for OSPP

\* The code J14000P creates a one point PT string AND a MOSS text string (\*A).

**Table 14 -4 NTF V1.1 feature codes (small scale 1:250 000 and 1:625 000)**



Feature code	Partial string label	Sub reference	Description
5040	*A		Cartographic Name, Settlement
5110	D	CHWM	Coast, Natural, HWM
5111	0	CMAN	Coast, Manmade
5115	P0	SSEE	Sea Seed
5120	0	FSSM	Foreshore, Sand, Margin
5121	P1	FSSE	Foreshore, Sand, Seed
5122	0	FSOM	Foreshore, Other, Margin
5123	P1	FOSE	Foreshore, Other, Seed
5124	P0	ROCK	Rock
5140	Z	LTHS	Lighthouse (in use)
5141	Z	LTSP	Lightship
5142	Z	LTSD	Lighthouse (disused)
5200	P0	UNOD	Unspecified Node
5211	0	MARV	Main River, Source
5212	0	MMRV	Main River, Middle
5213	0	MLRV	Main River, Lower
5221	0	SDRV	Secondary River, Source
5222	0	SLRV	Secondary River, Lower
5230	0	MIRV	Minor River
5240	0	CANL	Canal
5241	0	CANT	Canal Tunnel
5242	0	CANO	Canal, over other Feature
5250	0	LAKE	Lake, Margin
5251	P1	LSEE	Lake, Seed
5252	0	RESV	Reservoir, Margin
5253	P1	RSEE	Reservoir, Seed
5310	E	MWAY	Motorway
5311	E	MOUC	Motorway - Under Construction
5312	E	MOOF	Motorway, over other Feature
5320	G	DUPR	Primary Route, Dual Carriageway
5321	G	DCPR	Primary Route, D Carriageway under Const.
5322	G	DOPR	Primary Route, D C'way over other Feature
5323	G	SNPR	Primary Route, Single Carriageway
5324	G	SCPR	Primary Route, S Carriageway under Const.
5325	G	SOPR	Primary Route, S C'way over other Feature
5326	G	NWPR	Primary Route, Narrow
5327	G	NOPR	Primary Route, Narrow over other Feature
5330	F	DUAR	A Road, Dual Carriageway

5331	F	DCAR	A Road, D Carriageway under Const.
5332	F	DOAR	A Road, D Carriageway over other Feature
5333	F	SNAR	A Road, Single Carriageway
5334	F	SCAR	A Road, Single Carriageway under Const.
5335	F	SOAR	A Road, S Carriageway over other Feature
5336	F	NWAR	A Road, Narrow
5337	F	NOAR	A Road, Narrow, over other Feature
5340	H	DUBR	B Road, Dual Carriageway
5342	H	DOBR	B Road, D Carriageway over other Feature
5343	H	SNBR	B Road, Single Carriageway
5345	H	SOBR	B Road, S Carriageway over other Feature
5346	H	NWBR	B Road, Narrow
5347	H	NOBR	B Road, Narrow, over other Feature
5350	I	CROD	Minor/Other Road
5351	I	OFCR	Minor/Other Road, over other Feature
5353	I	TNCR	Minor/Other Road, Tunnel
5355	R	RDPR	Roundabout, Primary Route d/c
5356	R	RDAR	Roundabout, A Road d/c
5357	R	RDBR	Roundabout, B Road d/c
5358	F	STAR	A Road, Tunnel
5360	UE	SRVM	Motorway Services
5361	UE	SLVM	Motorway Services, Limited Access
5362	UE	SUVM	Motorway Services, Under Construction
5364	UF	SLVA	Primary Route Services - Limited Access
5365	UF	SRVA	Primary Route Services
5370	PE	MJUN	Motorway Junction
5371	PE	MJLA	Motorway Junction, Limited Access
5372	PE	MJUC	Motorway Junction, Under Construction
5373	G	STPR	Primary Route, Tunnel
5374	R	RDMR	Roundabout, Minor/other Road
5375	R	RSAR	Roundabout, Primary Route s/c
5376	R	RSAR	Roundabout, A Road s/c
5377	R	RSBR	Roundabout, B Road s/c
5379	PE	MULJ	Multilevel Junction
5380	P0	GRAD	Gradient, 1 in 7 or Steeper
5382	B	TOLL	Toll
5383	B	BRID	Bridge
5390	2	BOAT	Ferry, Vehicular
5411	S	CITY	City, Primary Route Destination
5412	QT	LTNP	Large Town, not Primary Route Destination
5413	QT	TOWN	Town, Primary Route Destination

5414	QT	TONP	Town, not Primary Route Destination
5415	QV	VILL	Village, Primary Route Destination
5416	QV	VINP	Village, not Primary Route Destination
5420	4	LURB	Large Urban Area, Margin
5421	P4	LUSE	Large Urban Area, Seed
5422	3	SURB	Small Urban Area, Margin
5423	P3	SUSE	Small Urban Area, Seed
5510	9	SRAL	Railway, Standard Gauge
5511	9	SRAO	Railway, Standard Gauge over other Feature
5512	8	NRAL	Railway, Narrow Gauge
5513	8	NRAO	Railway, Narrow Gauge, over other Feature
5514	9	TRAL	Railway, Tunnel
5520	L	RSTN	Railway Station
5530	P9	LEVL	Level Crossing
5610	W	WOOD	Woodland, Margin
5611	PW	WSEE	Woodland, Seed
5618	P0	HSEE	Headland Seed
5619	P0	GSEE	Island Group Seed
5620	P0	ASEE	Geographical Area Seed
5621	P0	ISEE	Small Island/Island Seed
5710	7	NBON	National Boundary
5712	7	NBOS	National Boundary, Seaward Extension
5715	P7	NSEE	National Seed
5720	6	CBON	County Boundary
5721	6	CBOS	County Boundary, Seaward Extension
5722	6	CBLW	County Boundary, LWM
5723	6	CBOC	County Boundary, Cartographic
5725	P6	CSEE	County Seed
5726	P6	CDSE	County Seed, detached
5730	5	DBON	District Boundary
5731	5	DBOS	District Boundary, Seaward Extension
5732	5	DBOC	District Boundary, Cartographic
5733	P5	DSEE	District Seed
5734	P5	DDSE	District Seed, detached
5810	V	ROME	Roman Road
5812	V	ANTQ	Antiquity Detail, Linear
5815	PV	FORT	Hill Fort
5816	PV	BATL	Battlefield
5820	N	NPAR	National Park Boundary
5821	PN	NSEE	National Park Seed
5825	J	LPAT	Long Distance Footpath

5835	X	MAST	Radio Mast
5840	T	AIRN	Civil Aerodrome (No Customs facilities)
5841	T	AIRC	Civil Aerodrome (Customs facilities)
5844	X	WMIL	Windmill
5845	T	HELI	Heliport
5313	E	MTNL	Motorway Tunnel
5359	H	BTNL	B Road, Tunnel
5363	UE	SLUM	M/way Services, Lmted Access, Under Const.
5378	PE	MULU	Multilevel Junction, Under Construction
5711	7	NBOC	National Boundary, Cartographic
5842	T	AIRP	Airport

**Table 14 -5 NTF V2.0 feature codes (small scale 1:250 000  
and 1:625 000)**

## Running the program

The OS digital data must first be converted to MOSS GENIO format. The data is then input to MOSS in the normal manner, as described in this manual.

MSOSPP is invoked as a standalone program and uses a series of prompts to guide you.

Type *MSOSPP*

Do you wish to convert your Ordnance Survey data from a blocking format to an OSTF/DMC format (Y,N)?

Type 'y' if you wish to convert an 80 character block file into a standard 8 character block OSTF file.

Otherwise type 'N'

Enter name of file containing Ordnance Survey data.

Type the name of your input file if not given a suffix of '.INP' is assumed.

Enter name of output file:

Type the name of your output file.  
If not given a suffix of '.FIL' will be appended to your output file name.

Which format is your O.S. data (OSTF, DML or NTF)?

Type *DMC* for DMC format  
*OSTF* for OSTF format  
or *NTF* for NTF format.

Enter the name of the file containing OS Data

Type the name of the file.

The program will assume the suffix .FIL unless a full file name is given. If the file is not found, a warning will be issued. The program will stop, or will prompt for another filename.

Enter the name of the output file. [Return] for default.

Type the name of the file. [Return]

The default suffix for the output file is .GEN. MAP1.FIL will be processed to become MAP1.GEN by default. If a prefix only has been given the suffix .GEN will be added.

An OS data file may contain many maps but you may not wish to process them all. Single or multiple maps can be selected for

processing by searching for their bottom left coordinates and drawing scale in the OS file. This information is then held in a map coordinate file in the format shown below.

```
column no          123456789012345678901234
record             446000  517500  1250
```

```
                E      N      scale
```

Do you wish to process specific maps on data file  
?

Enter file name containing map coordinates:

[Return] for all maps

Type <filename> or [Return]

### Notes

- ◇ *Certain machines will give you additional opportunities to manipulate your input file.*
- ◇ *MSOSPP produces no direct output to the screen. An OSPP.LOG file is created containing the names of all maps processed and any errors or warnings produced.*

## Errors and warnings

An error will stop the MSOSPP process from generating any further output to the .GEN file for the current map. The program will go on to process any further maps required. A warning does not stop output for the current map.

### Error E1

```
E1 - invalid OS marker code : 'code'  
      on line number : 'num'
```

The program has encountered a marker code which it is not expecting. Valid codes are :

-1, -2, -3, -4, -5, -20, or -21

Error E1 will be generated and the line number will be placed in the .LOG file.

### Error E2

```
E2 - invalid OS text marker code : 'code'  
      on line number : 'num'
```

The program has encountered a marker code which is not valid for a text feature. Valid codes are:

-18, -9, -14, -10, -11 -12

Error 2 will be generated and the line number will be placed in the .LOG file.

### Error E3

```
E3 - invalid OS symbol marker code : 'code'  
      on line number : 'num'
```

The program has encountered a marker code which is not valid for a symbol feature. Valid codes are:

-9, -15

Error E3 will be generated and the line number will be placed in the .LOG file.

**Error E860**

ERROR ON LINE `num` - DATAFILE FORMATTED  
INCORRECTLY

This error is given for each record in the feature code data file with wrongly formatted or spurious data, together with the line number on which the error is found.

**Error E861**

ERROR ON LINE `num` - FIELD NOT LEFT JUSTIFIED

A field in a record in the feature code data file is not left justified. See 'Feature code data file' for a description of the data file format.

**Error E862**

NUMBER OF CODES IN OS1TAB.DAT EXCEEDS MAXIMUM OF  
`num`

The number of feature codes in your data file exceeds the currently allowed maximum.

**Warning W6**

Certain feature codes will be ignored by the MSOSPP program since they are not shown on OS plans. See DMC or OSTF documentation for details.

The warning will be displayed and the program will continue to process the data.

**Warning W7**

- warning - blank line encountered on line number `num`

This warning will be displayed when a blank line is encountered in the data file. The blank line will always be ignored except when it is required as 'text' for a 'text string feature'.

After inputting the GENIO data to the model file many of the facilities within the MOSS system become available. However, the resulting MOSS model is only 2D and so cannot be used for sectioning, contouring or volume calculations.

**Warning W925**

WARNING - FEATURE CODE `code` REPEATED IN DATA  
FILE.

This warning is written in the log file for each feature code which is duplicated in the feature code data file.



**Warning W926**

WARNING - FEATURE CODE 'code' HAS BEEN IGNORED

This warning is written in the log file for each feature code which does not have a corresponding entry in the feature codes data file, if there is no 'NULL' record in the data file.

**Warning W927**

WARNING - FEATURE CODE 'code' TREATED AS NULL CODE

This warning is written in the log file for each feature code which does not have a corresponding entry in the data file and if a 'NULL' record has been coded in the data file.

**Warning W928**

WARNING - 'num' STRINGS IGNORED

**Warning W929**

WARNING - 'num' STRINGS TREATED AS NULL

**Warning W930**

WARNING - UNKNOWN RECORD IDENTIFIER 'code',  
IGNORED

**Warning W931**

WARNING - BLANK LINE ENCOUNTERED AND IGNORED

**Warning W932**

WARNING - NOT ENOUGH COORDINATES ON LINE 'num'

**Drawing the maps**

To produce a simple line drawing at any scale you can use basic DRAW minor options. However, a DRAW macro ORDSDRAW has been developed to draw large scale digital maps, which assigns the appropriate linestyles and the required symbols. Any marginal notes transferred can be added using major option ENHANCE.

**Macro ORDSDRAW**

This macro uses DRAW minor options which invoke various macro symbols, line styles and detail interpretation to represent Land-line large scale topographic information to OS 88 or OS 93 specification.

◇ *If you have modified the feature codes data file, this macro may produce incorrect results.*

(the default is 1/2500).

Example

900,ORDSDRAW

\*

999

The macro is based on PLANDRAW. For a full explanation of the parameters used you should refer to the PLANDRAW documentation.

In the following:

PV implies any positive value

CV implies any characters

## Input

Code	Description	Alternatives	Default
FD	First drawing if there is overplotting or if SL or SW are to be specified.	"	-
OD	Subsequent drawing if there is overplotting.	"	-
PA	Paging	NOPA PAGE	PAGE
TR	Truncation	NOTR TRUN	NOTR
SL	Sheet length	PV	
SW	Sheet width	PV	
FR	Framing	FRAM NOFR WIND	NOFR
ML	Left margin		1.0
MB	Bottom margin		1.0
MT	Top margin		1.0
MR	Right margin		1.0
XL)	Relationship of model to drawing	PV	
YL)	Coordinates of bottom left point and	PV	
BE)	bearing of left hand side	PV	
LC	String colour	CV	BLACK
TC	Text colour	CV	BLACK
GR	Grid	NOGR FULL CROS EDGE REGR	NOGR
XG	X spacing of grid	PV	100
YG	Y spacing of grid	PV	100
SC	Scale	PV	2500
IO	Inside or outside a boundary	IN	

		OUT	
BD	Boundary string label if IO=IN or IO=OU	CV	-
XB)	Minimum model coordinate restricting	PV	0.000
YB)	region to be drawn	PV	
XT)	Maximum model coordinate restricting	PV	99999999.9
YT)	region to be drawn	PV	99999999.9
SING	Draw model as single segment	SING	-
EDG	Draw boundary and administrative text	000	-

Output

Figure 14 - 3 shows a drawing produced by macro ORDSDRAW.



The material contained in this diagram has been reproduced from Ordnance Survey map data with the permission of the Controller of Her Majesty's Stationery Office, ©Crown copyright.

**Figure 14 - 3 Example of 1:1250 map drawn with the ORDSDRAW macro**

## Program MSMODCNV

MSMODCNV is a stand alone program which converts a binary MOSS model file saved on the current platform to a binary MOSS model file for the PC. The PC file format is compatible with MS-DOS, MS-Windows 3.11, Windows 95 and Windows NT.

The program must be installed and executed on the machine containing the model file to be converted.

The program MSMODCNV Version 1.0 will convert all model files created with MOSS versions up to and including Version 10.3.

Versions of MSMODCNV exist for the Apollo Domain, VAXstation, DEC Alpha /VMS, Sun Solaris 1 and Solaris 2, HP-UX, IBM RS/6000 and Silicon Graphics platforms.

DECstation model data is binary compatible with the PC; it does not therefore require conversion.

The program has the following features:

- The conversion retains 'negative coordinate' data.
- The original model file is retained intact.
- All model types except the IDIGIT transformation model can be converted.
- All messages and prompts are in English.

### Before running the program

Prior to any model file data conversion being undertaken, you must confirm the integrity of the model file by running REPORT 987 within MOSS. This will identify any corrupt pointers that may exist within the model file.

Archive and dump files must be restored to a model file before conversion can take place.

Before running the program, move to a directory containing the model file(s) to be converted. You will also require free disk space equal to twice the size of the model file to be converted.

## Running the program

To start the program:

Type *msmodcnv* <Return>

If there is a *bcpt.dat* file present in the current directory, the files listed are converted. If no *bcpt.dat* file is present, a single model file named *model.fil* will be converted to a PC compatible file named *model.mpc*. In this case, a *bcpt.dat* file is created in the current directory.

An error file *bcpt.log* is also created which contains any errors that were reported.

- ◇ *If you are converting a single model file (ie, there is no bcpt.dat file in the current directory), and no model file 'model.fil' exists in the current directory, the program will fail, but it will leave a copy of bcpt.dat which you can edit before running the program again.*
- ◇ *If you are converting multiple model files, and one or more of the model files listed in bcpt.dat does not exist in the current directory, the program will fail.*
- ◇ *You cannot convert model files with different coordinate origins in a single operation.*

## Creating a 'bcpt.dat' file

Multiple model files can be converted by creating a *bcpt.dat* file. Before running the program, create or edit a *bcpt.dat* file as shown in the following example:

```
modelfilename1.fil
modelfilename1.mpc
modelfilename2.fil
modelfilename2.mpc
modelfilename3.<xxx>
modelfilename3.<yyy>
999
0,0
```

where <xxx> and <yyy> are alternative model file extensions for the input and output model files respectively.

The last line should always be 0,0 unless a negative coordinates origin has been specified.

Values should then be selected from the parameter file settings X\_OSHIFT and Y\_OSHIFT used when the model file was created. Typical values are 10000000,10000000. The values must be integers and separated by a comma.

## Output

The program creates PC-compatible model files and a commentary file *bcpt.log* which contains diagnostic data. It also creates a conversion file *bcpt.dat* if one does not already exist.

The file *bcpt.log* contains string header information for each string in every model on a model file that has been converted. A log of the models which have been converted is also output to the screen.

## Program MSDPFCNV

MSDPFCNV is a stand alone program which converts a binary MOSS Draw Picture File (DPF) saved on the current platform to a binary MOSS DPF for the PC. The PC file format is compatible with MS-DOS, MS-Windows 3.11, Windows 95 and Windows NT.

The program must be installed and executed on the machine containing the DPF to be converted.

Versions of MSDPFCNV exist for the Apollo Domain, VAXstation, DEC Alpha /VMS, Sun Solaris 1 and Solaris 2, HP-UX, IBM RS/6000 and Silicon Graphics platforms.

DECstation DPF data is binary compatible with the PC; it does not therefore require conversion.

The program has the following features:

- The original DPF is retained intact.
- All messages and prompts are in English.

### Before running the program

Before running the program, move to a directory containing the DPF(s) to be converted. You will also require free disk space equal to twice the size of the DPF to be converted.

You must ensure that the macro file *macro.fil* containing the lines and symbols used in the DPF is present in the same directory.

### Running the program

To start the program:

Type *msdpfcnv* <Return>

The program will ask:

```
Do you wish to convert all DPFs in the current
directory ?
```

If you answer (y)es, all DPFs in the directory with the suffix '.dpf' will be converted. Otherwise, if there is a *dcpt.dat* file present in the current directory, the files listed are converted. If no *dcpt.dat* file is present, a single DPF named *draw.dpf* will be converted to a PC compatible file named *draw.dpc*. In this case, a *dcpt.dat* file is created in the current directory.

A macro file *macro.dpc* and an error file *dcpt.log* are also produced. The macro file contains all the macro lines and macrosymbols used in the DPF(s), and the error file contains any errors that were reported.

- ◇ *If you are converting a single DPF (ie, there is no dcpt.dat file in the current directory), and no DPF or macro file 'macro.fil' exists in the current directory, the program will fail, but it will leave a copy of dcpt.dat which you can edit before running the program again.*
- ◇ *If you are converting multiple DPFs, and one or more of the listed DPFs does not exist in the current directory, the program will fail.*
- ◇ *The file 'macro.dpc' will contain only those macrolines and macrosymbols present in the converted DPFs.*

### Creating a 'dcpt.dat' file

Multiple DPFs can be converted using a *dcpt.dat* file. Before running the program, edit the *dcpt.dat* file as shown in the following example:

```
macro.fil
macro.dpc
drawing1.dpf
drawing1.dpc
drawing2.dpf
drawing2.dpc
999
```

### Output

The program creates PC-compatible DPFs and a commentary file *dcpt.log* which contains diagnostic data. It also creates a macro file containing all the macro lines and macrosymbols used in the DPF(s).

The file *dcpt.log* contains string header information for each string in each DPF which has been converted. A log of the DPFs which have been converted is also output to the screen.

## MICRORAT and WALLRUS

MICRORAT and WALLRUS are drainage design programs developed by Hydraulic Research Ltd of Wallingford. MOSS Systems supplies them under licence to sites who are also MOSS users (but not to sites who are not MOSS users). They may be run either from within MOSS via the SUBSYSTEM option, or as external programs.

There is also a direct transfer of data from MOSS to WALLRUS via major option DRAINAGE.

### Running the program

Within MOSS

From the SUBSYSTEM prompt, select WALLRUS or MICRORAT. The program will be accessed directly.

For all other information see the WALLRUS User Manual.

Type *WALLRUS* or *MICRORAT*

Externally

The program will be accessed directly.

For all other information see the WALLRUS User Manual.

## MSLOTTER

The MSLOTTER program which is developed by MOSS Systems Ltd, produces a drawing on a machine plotter by accessing the DPF (Draw Picture File). You run it via a series of simple menus by which you can choose to draw specific sheets, as follows:

First, type *MSLOTTER*

You get a list of the plotters available on your system.

Type in the name of the one you want (if your system has only one plotter it will automatically engage it).

You are then prompted for the name of the DPF that MSLOTTER is to read the data from.

Finally, if there is more than one sheet you are prompted for the sheet number.



- ◇ *A SUBSYSTEM function SUBPLOT permits you to access the stand alone program from within MOSS. In every respect SUBPLOT operates identically to MSPLOTTER.*
- ◇ *Different manufacturers of plotters supply different methods of driving their equipment, and the programs as supplied to users cater for the popular makes of plotter. Should your plotter not fall into this category a 'Plotter Kit' can be supplied.*
- ◇ *The actual administration of plotting varies from one installation to another and your System Manager will clarify your particular arrangements.*

## MSDISPLAY

The MSDISPLAY program which is developed by MOSS Systems Ltd, allows you to view any DPF (Draw Picture File). To enter MSDISPLAY proceed as follows:

First, type *MSDISPLAY*

You will be prompted for the filename to be viewed

Type, *filename* or *filename.dpf*

If the DPF named contains more than one sheet, you will be prompted to enter the sheet required

Type, *1*

MSDISPLAY will display the DPF requested, and allow you to change sheets, zoom and window the displayed picture.

- ◇ *Any action you take whilst in MSDISPLAY will not change the content of the DPF file.*

## Program MSMIFILE

The MSMIFILE program is developed by MOSS Systems Ltd. It produces a MOSS Intermediate File (MIF) from the drawing information held on the DPF (the file used by MOSS to store details of pictures created by major options DRAW and ENHANCE).

The MIF is a simplified representation of the DPF and contains all the information to reconstitute a MOSS drawing. The drawing can be a plan, section, perspective view, or a composite of all types.

Some complementary systems provide a feature within their own software which reads the MIF and generates their own graphical

database from the information supplied. The MIFILE is the accepted interface between MOSS and other complementary CAD systems.

The MIFILE option is available as a major option within the MOSS program or as a standalone program. Within MOSS, MIFILE operates on the current DPF, the standalone program operates on a named DPF. When MIFILE is invoked the user is asked whether Full Vector Representation is required. The reply to this depends upon the requirements of the CAD system that is to receive the MIFILE. If the CAD system is capable of recreating macro symbols, macro lines and MOSS dashed lines from their definition at the top of the MIFILE, then vectors are not required. The CAD system vendor should be consulted as to the requirements of the particular system. The MIFILE is a one way transfer of pictures out of MOSS. There is no reverse operation available. The information stored is 2D only. If 3D and or reverse transfer is required then major option GENIO or 3DDXF and MSDXFMOSS must be used.

### Running the program

From linemode within MOSS:

Type *MSMIFILE*

The program will prompt:

'Do you want full vector representation?'

Reply *YES* or *NO*

If you choose full vector representation each time a symbol or line style is used the individual vectors will be generated onto the MIF. The alternative is to allow the receiving system to build up the lines and symbols from its own symbol table.

You must reply YES or NO depending upon the requirements of the system to receive the MIF.

There are no other prompts unless the current DPF has more than one page, in which case you will be prompted to give the page number required.

Once the dialogue is finished the system will return you to linemode. The file created is named DRAW.MIF but at the end of your MOSS session you will be asked if you wish to give DRAW.MIF a more suitable name.

Externally

Type *MSMIFILE*

The program will prompt for the name of a DPF to be converted.

If you give a null response, DRAW.DPF will be assumed.

The program will prompt:

Do you want full vector representation?

Reply *YES* or *NO*

If there is more than one page, you can choose which pages to convert.

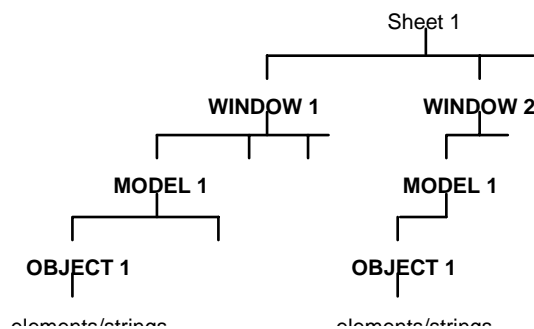
Once completed you will be prompted for another DPF name.  
When you are finished, simply reply FINISH.

## Program MS2DDXF

MS2DDXF is a standalone program, developed and supported by MOSS Systems Ltd, which takes the MOSS DPF as input and generates a file in DXF format, ready for input to AutoCAD or similar drafting packages.

The structure of the MOSS drawing can be retained as layers within the DXF structure. A MOSS drawing is made up of the following groups:

- Sheets
- Windows
- Models
- Objects



**Figure 14 - 4 MOSS group levels**

The groups have a hierarchic structure in that sheets contain windows, windows contain models and models contain objects. At any level in the structure, DXF layers can be created for each colour/linestyle combination in a group.

A configuration file describes which groups are to be skipped, divided or allocated. The configuration file can either be prepared previously or created during the actual run.

- To *Skip* is to omit the group from the transfer.
- To *Divide* is to progress to the next group level down.
- To *Allocate* is to put the current group into DXF layers, one for each pen colour.

The highest grouping structure is to *Allocate* the entire sheet onto one DXF layer. The lowest and most detailed structure is to *Divide* all sheets, windows and models, and create one DXF layer for each colour/linestyle combination within a MOSS drawing object.

◇ *It is advantageous to set up objects in your DRAW input data if the drawing is to be passed to a drafting system via 2DDXF as these objects dictate the layer names produced.*

The MOSS colours on the drawing are automatically mapped to AutoCAD colours using a colour map file. If you want non-standard colours, you can change this file.

### Line style conversion

Line style definition within the DXF file is restricted to a series of dots and dashes, ie is one-dimensional. No element within the series may be rotated. For example, the MOSS two-dimensional line style for a fence drawn using detail interpretation on 'F' strings cannot be reproduced with DXF. For this reason, blocks are used to recreate fence line styles. However, for any MOSS line style where the elements are not rotated an equivalent DXF line style may be created.

Layers in the DXF file are created such that elements having different line styles are placed on different layers. The line style for the layer is then set appropriately. See the section below on automatic layer naming for further details.

AutoCAD version 12 applies one-dimensional line styles to elements in the same manner as MOSS. Releases of AutoCAD prior to this apply line styles as follows:

- If the basic unit describing a MOSS line style does not fit between points a continuous line style is used.
- Each vector of an element always starts with the basic unit.

This means that elements may appear partially or completely in continuous line style.

To avoid these problems, do not generate DXF line styles when running the program. The lines will then be generated as individual elements, which simulate the required line style.

### Blocks created by MOSS

MOSS creates a block in a DXF file for the following items of picture information:

- A macrosymbol
- The basic unit used to describe a two-dimensional line style in DRAW or ENHANCE, minor option 810.
- The basic unit used to describe a macroline, held on the macro file.
- Information drawn in relation to a string, or ENHANCE element, with a single command. This enables the information to be selected with a single pick in AutoCAD.

Blocks must have a unique name in the DXF file and since more than one set of information may be drawn from a single string, the convention 'stringlabel\_\_uniquenumber' is used. For example, macro symbols at horizontal tangent points and chainages may both be drawn on a master string.

### Automatic layer naming

The automatic layer naming convention at different stages of allocation is as follows:

#### **At window level:**

XYYZZ\_ \_ \_ \_ \_NL

where:

X	is the sheet number
YY	is the window number
ZZ	is the window type number
	01 - Plan
	02 - Long section
	03 - Cross section
N	is the AutoCAD colour number
L	is the line style number

#### **At model level:**

model\_nameNL

where:

model\_name is the model name, maximum 10 characters

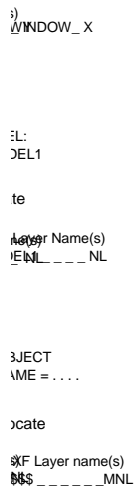
N is the AutoCAD colour number  
L is the line style number

**At object level:**

\$\$\$\$\_ \_ \_ \_ \_MNL

where:

\$\$\$\$ is the object name, 4 characters  
M is the dashed line style number  
(only used if DXF line styles are generated)  
N is the AutoCAD colour number  
L 1 - continuous line style  
3 - DXF line style



**Figure 14 - 5 Automatic layer naming conventions**

It is therefore advisable that objects are explicitly named in the DPF, as allowing use of default object names can result in different objects in different windows being placed in the same layer, as the above diagram illustrates.

- ◇ *The maximum number of characters that can be transferred from a text string or enhanced element is 32.*

## Running major option 2DDXF

### Graphics

Select 2DDXF from Drawing options menu.

◇ *DRAW.DPF (the current display will be assumed).*

### Linemode

Type *2DDXF*

This will assume DRAW.DPF

## Running the program standalone

You run MS2DDXF as a standalone program.

The prompts and procedure are as follows:

Type *MS2DDXF*

Type the name of the DPF to be converted

Type *<filename>*

Do you want to make the following assumptions:-

Create a new configuration file called :-

*<filename>.cfg*

Assume Automatic layer naming

Divide entities to object level,

Overwrite the DXF file if it already exists (Y/N)?

Type *Y or N*

If you respond *NO*, you do not have the option to generate DXF line styles and you will be prompted as described under 'Standard DXF line styles'.

If you respond *YES*, you are prompted as described under 'Generated DXF line styles'.

## Generated DXF line styles

Generate DXF line styles (Y/N)?

Type *Y or N*

If you respond *YES*, DXF line styles are generated from the MOSS line styles.

If you respond *NO*, line styles are simulated using individual elements.

The translation then takes place and when it is complete you are prompted for another DPF file name (see notes).

### Standard DXF line styles

Type either - The name of the Config file to be used

or - FINISH to end procedure

Type *<configuration file name>*

The configuration file gives details of how the DXF file is to be layered. If you give a null response the name will default to that of the DPF.

If the file already exists you will be asked whether you wish to use it or whether you want to create a new one.

Do you want automatic layer naming? (Y/N)

Type YES or NO

If you respond YES, the MOSS model and object names are used as layer names when the entities are allocated. As each layer is created, the name allocated is reported.

If you respond NO, you will be prompted to supply a name each time an entity is allocated. If you give a null response, then the MOSS name is adopted.

As each MOSS group entity, sheet, window, model, or object is encountered you will be prompted to Skip, Allocate, or Divide. At object level the only available options are Skip or Allocate.

Select action for SHEET/WINDOW/TYPE-

Type either - S to skip

or - D to divide

or - A to allocate

Type S, D or A

If invalid (or greater than 10) characters are encountered you will be prompted to supply a new name. Some translations will be done automatically. For example:

- 32 commas – this is the MOSS model for enhancement and will become ENHANCE
- 4 dots – the MOSS default object name becomes '\$\$\$\$'. Thus two undefined objects in the DPF have the same default name and will therefore go in the same DXF layer.
- /NNN – the automatically-created MOSS labels become '\$NNN'

2DDXF creates a separate layer for each colour/line style combination within each of the MOSS DPF grouping levels.

On completion of the translation, an output file is generated with the same name as the DPF input, but with the suffix .DXF



The program will loop again if more DPFs are to be translated. To exit, type FINISH.

### Files used

A number of files are accessed by the MS2DDXF program:

- The MOSS parameter file (PRMFIL.FIL)
- The MOSS message file (MESFIL.FIL)
- The DXF colour map file (ACCOLOUR.DAT)
- The program message file (MIDXF\_MSGS.DAT)
- The DPF input (filename.DPF)
- The configuration file (filename.CFG)
- The output DXF file (filename.DXF)
- The output report file (MIDIAGNOS.DAT)

### Getting into AutoCAD

Type *AutoCAD*

Select 'Create New Drawing' (without prototype)

Give it a name, the same as the DXF file.

Use the DXFIN command to load the drawing.

## Program MSDXFMOSS

MSDXFMOSS is a standalone program which takes a file in DXF format and from this file generates a file in MOSS GENIO format, ready for input to MOSS. This allows MOSS to label strings automatically as they are entered via GENIO.

There are two methods of data transfer which you may use:

The first method transfers blocked data to separate models in MOSS, with the block names used in the DXF file being used as the model names in MOSS. Unblocked (ie, layered) data is transferred to models having the same name as the containing layer.

The second method allows you to transfer all blocked and unblocked data into a single named model, or separate models if preferred.

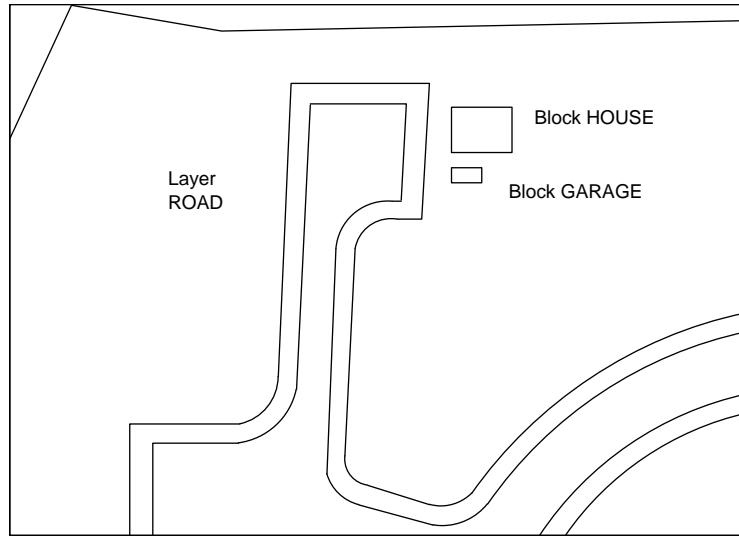
The following rules apply when generating a GENIO file:

- For blocked data, string label roots are formed from the first two valid characters of the containing block name. Invalid characters include all non alphanumeric characters and the character P which is used to denote point strings in MOSS.

In addition, each block placement point is added to a special string with the label PSMP. In MOSS, you can use this string to place symbols which you wish to include in your drawing which were not transferred from the DXF file. For example, cadastral symbols transferred as individual strings can be deleted and the equivalent symbol added to the PSMP string (or part of it) using major option DRAW or ENHANCE.

- For unblocked data, string label roots are formed from the first two valid characters of the containing layer name.
- Arcs and circles are transferred as 3-dimensional strings with points calculated according to the specified chord-to-arc tolerance.
- Text is transferred as text strings partially labelled with \* .
- Solids, traces, meshes, symbols, 3D faces and similar objects are ignored.

When the naming conventions have been applied, you may display tables showing the derived model names and string label roots of both blocked and layered information. You may edit these tables to override any string label root or model name via interactive options before producing the GENIO file.



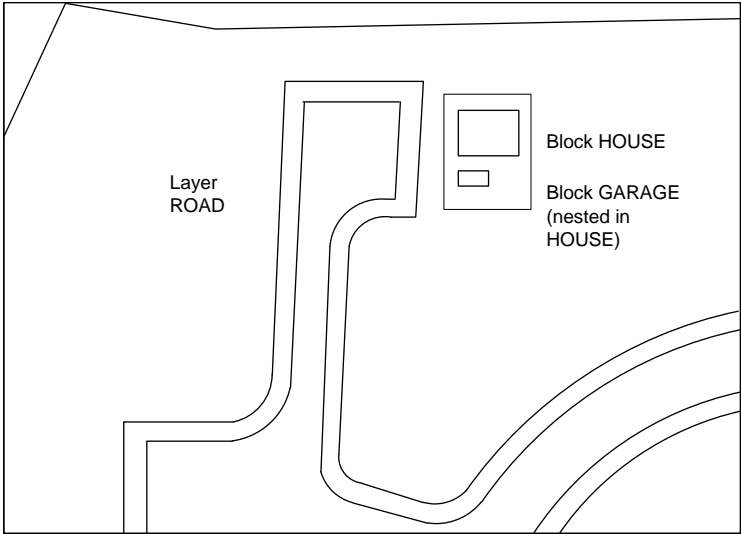
BLOCKED INFORMATION TABLE (1)

Ref.	Block name	Model name	lb	rt	Ref.
1	HOUSE	HOUSE	HO		1
2	GARAGE	GARAGE	GA		2

LAYERED INFORMATION TABLE (1)

Ref.	Layer name	Model name	lb	rt	Ref.
1	ROAD	ROAD	RO		1

**Figure 14 - 6 MSDXFMOSS naming conventions (separate blocks)**



BLOCKED INFORMATION TABLE (1)

Ref.	Block name	Model name	lb	rt	Ref.
1	HOUSE	HOUSE	HO		1
2	GARAGE	-* This block is nested *-	GA		2

LAYERED INFORMATION TABLE (1)

Ref.	Layer name	Model name	lb	rt	Ref.
1	ROAD	ROAD	RO		1

**Figure 14 - 7 MSDXFMOSS naming conventions (nested blocks)**

**Running the program**

While running the program, you can obtain help by typing '?' in response to any prompt labelled with (?).

At the operating system prompt:

Type *MSDXFMOSS*

DXF input file name (?) :

Type the name of the DXF file to be converted, eg, *ground.dxf*

CRD output file name (?) :

Type the name of the GENIO file to be generated, eg, *ground.crd*

Type model naming method (1/2/?/Q) [1] :

- Type 1 or 2 depending upon the naming convention you require.

If you type 1, model names will be derived from block and layer names in the DXF file.

If you type 2, you will be prompted for the names of the models for both blocked and unblocked data.

Type DXF drawing units ... (1/2/3/?) [1] :

- Type the number corresponding to the drawing units in use when the DXF file was created. These can be metres, centimetres or millimetres. This information allows the MOSS models created from the generated GENIO file to have the correct linear units.

Type chord to arc tolerance (?/Q) [0.6] :

- Type the chord to arc tolerance to be used when generating strings which represent arcs. This value determines the number of points which are created on the string, with larger values producing less points on the string.

Type X coordinate shift ... (Q/?) [0.0] :

- Type the value by which you wish to shift each X coordinate in the DXF file.

A coordinate shift can be used to input negative coordinates from DXF to MOSS. However, the shift you apply here should be identical to the shift stored in the parameter file, in order that coordinates read from the MOSS model file may have the shift reversed.

Type Y coordinate shift ... (Q/?) [0.0] :

- Type the value by which you wish to shift each Y coordinate in the DXF file.

Transfer X scaled text ... (Y/N/Q/?) [Y] :

- Type *y* if you wish to transfer X scaled text.  
Type *n* if you do not wish to transfer the text.

Drawing scale used in MOSS .. (Q/?) [1:500]

- Type the drawing scale to be used when the GENIO file is input to MOSS and drawn.

The scale entered is used to adjust the height of text strings so that text is sized correctly when it is drawn in MOSS at the specified scale. If a different scale is used in MOSS, the text will not be drawn with the expected height.

MOSS does not support X scaling, and so any X scaled text you transfer may exceed its original space.

Interpret 0.0 levels as NULL ... (Y/N/Q/?) [Y] :

- Type *y* if you wish to interpret points with a Z coordinate of 0.0 as null level points. Otherwise, type *n* to leave the Z coordinate as 0.0.

Generate naming tables ... (Y/N/?/Q) [Y] :

At this point in the program, you are given the choice of generating naming tables or the GENIO file. If you wish to inspect or modify any of the allocated string labels or model names, you should generate naming tables; otherwise, you should create the GENIO file.

- Type *n*

```
Reading ground.dxf
      796 Lines read
```

```
Generating ground.crd
Generating ground.dat
```

DXF to GENIO complete.

Do you wish to convert any more DXF files (Y/N)  
[N] :

- Type *n*

DXF to GENIO complete.

## Output

The program creates two files, a GENIO file (.crd) and a data file (.dat) which contains diagnostics data.

The GENIO file contains two commented out lines for each model referenced in the file. These lines use major options DELETE and CREATE to ensure that any existing models of the same name are overwritten. Remove the spaces at the beginning of these lines if you wish this to happen.

The data file contains various statistics concerning the DXF to MOSS conversion and shows any data which has not been transferred.

**Example****GENIO file (.crd)**

```
DELETE, SQRS
CREATE, SQRS
GENIO SQRS
001, FORMAT(3F16.7)
003, ORDR, 4=1, 1, 2, 3,
080, SQ, 5=0.0, 6=0.0, 7=7703
      1.0000000      4.0000000      0.0000000
      1.0000000      5.0000000      0.0000000
      2.0000000      5.0000000      0.0000000
      2.0000000      4.0000000      0.0000000
      1.0000000      4.0000000      0.0000000
      0.0000000      0.0000000      0.0000000
080, SQ, 5=0.0, 6=0.0, 7=7703
      1.0000000      2.0000000      0.0000000
      1.0000000      3.0000000      0.0000000
      2.0000000      3.0000000      0.0000000
      2.0000000      2.0000000      0.0000000
      1.0000000      2.0000000      0.0000000
      0.0000000      0.0000000      0.0000000
999
FINISH
```

**Data file (.dat)**



DXF to GENIO diagnostics file.

-----

DXF file used : test2.dxf

No. lines read : 796

CRD file created : test2.crd

ENTITY TYPE	NUMBER USED	NUMBER IGNORED
POLYLINE	1	0
BLOCK	2	0
INSERT	3	0

Number of macrosymbol placement points in PSMP string is :  
2

Chord to arc tolerance used : 0.600

DXF drawing units scaled by : 1.0

X coordinate shift : 0.0

X\_OSHIFT in your parameter file should be set to :  
0.0

The min X coordinate of the DXF file is : 0.0

Y coordinate shift : 0.0

Y\_OSHIFT in your parameter file should be set to :  
0.0

The min Y coordinate of the DXF file is : 0.0

X scaled text has been transferred.

0.0 levels interpreted as NULL.

Model containing BLOCKED data :- SQRS  
Number of text stings = 0  
Number of point strings = 0  
Total number of strings = 2

## Program MSMINT

MSMINT is a standalone program which translates a file from Intergraph SIF format to MOSS GENIO format. Information may be transferred as either two dimensional or three dimensional data.

### Terminology

Standard MOSS terminology is used to describe MSMINT. Therefore, 'level' is used to mean 'Z coordinate' unless it appears in italics in which case it is used to mean level in SIF terminology, ie, the layer on which data resides.

### SIF to GENIO

#### 2D transfer

2D transfer writes GENIO files with null levels (-999.0) throughout.

#### 3D transfer

3D transfer writes GENIO files with the same levels as those found in the SIF file. Points without levels are allocated null levels (-999.0). If all points in a SIF structure have the same level, the structure is transferred as a 2D contour string.

Circles and arcs are converted to MOSS strings with sufficient points that the specified chord-to-arc tolerance is satisfied. The first (or only) level in the SIF file for the circle or arc is assigned to all the points on the MOSS string.

### Coordinate shift

A plan (ie X and Y) coordinate shift may be applied to data which is transferred from SIF to GENIO. This is particularly useful for removing negative X and Y coordinates from SIF data.

### MSMINT label file

The label file contains the translation rules for converting Intergraph strings into MOSS strings. It is an ASCII file containing a number of fixed width (8 character) fields used during the translation process. The first line of the file is ignored, and may be used to provide column headings for each field. For example:

```
String->Level-->Type--->Colour->Weight->Style-->Cell--->Comment-->
DA??      3      C      3      2      2      2D contour
E????     2      S      2      1      1      3D lines
GT??      1      P      1      1      1      GATE  Gates
I????     6      I      6      1      1      Ignore
L????     5      L      5      1      1      Pt levels
TR??      1      P      2      1      1      TREE  Trees
*????     4      T      4      1      1      1000  Text
```

The label file may be generated automatically by MSMINT. See 'Running the program' for further details.

The following paragraphs describe the fields used in the label file.

#### String

This field contains the MOSS string labels to be produced from SIF *levels*. The labels should be entered in alphanumeric order and include question marks to denote where a match can be made with any character.

For example, using the example label file shown, all strings on Intergraph overlay *level 2* will translate to MOSS strings beginning with 'E' in the GENIO file.

#### Level

This field contains the SIF overlay *level* number. The *level* number is used in conjunction with the MOSS string label in Field 1 to determine how SIF strings are mapped to MOSS strings, except when converting point coordinates (see 'Type').

## Type

This field contains a code specifying the string type.

- **P** point string
- **S** 3D string
- **C** 2D contour string
- **T** text string
- **L** level string
- **I** ignore indicator

The **point string** code is used to indicate that each point on the string represents the location of a single symbol rather than a connected series of points. The symbol to be used at each point on the string is given in the Cell field (see 'Cell').

The **3D string** code is the most commonly used code and indicates that points on the string represent a connected series of lines.

The **2D contour string** code is generally used when generating a 3D GENIO file. If all points in a SIF line have the same Z coordinate, then the line should be converted to a contour string.

The **text string** code is used to indicate the *levels* which generate text strings. A text string has a label beginning with an asterisk (\*).

The scale factor used to size text is given in the Cell field (see 'Cell'). This is required because text uses drawing coordinates in MOSS and real world coordinates in Intergraph. The text size is divided by this factor when generating a GENIO file.

The **level string** code is used when generating a GENIO file to create level strings.

The **ignore indicator** is used to indicate that strings defined in the same line of the table are to be ignored by the conversion process.

**By default, any strings not mentioned in the label file are ignored**, but this code allows the user to record that this is the correct action, rather than an oversight in the label file.

## Colour

This field is used to specify the colour to be assigned to strings generated in the SIF file (not used).

## Weight

This field is used to specify the thickness to be assigned to strings generated in the SIF file (not used).

### Style

This field is used to specify the line style to be assigned to strings generated in the SIF file (not used).

### Cell

This field contains the name of the symbol to be placed at each position on a point string (see 'Type') when generating a SIF file. When generating a GENIO file, symbols with the name specified in this field are given the point string label in Field 1.

Alternatively, when converting text strings, this field contains the scale factor.

### Comment

All remaining space in each entry may be used for comments.

## Running the program

While running the program, you can obtain help by typing '?' in response to any prompt labelled with (?).

At the operating system prompt:

Type MSMINT

You are presented with a start up message followed by a menu:

```
MINT - MOSS/INTERGRAPH Conversion Utility
=====
```

1. GENIO to SIF file.
2. SIF to GENIO file.
3. Create LABEL file.
0. Finish

-?- A (?) shows help is available on the option.  
To obtain this help, just type '?' at prompt.

Enter option number (0-3/?) [0] :

### Create label file

Type 3 to create a label file if you do not already have one for the file you wish to convert.

Type SIF filename ... (?) :

Type the name of the file to be converted, eg, *plan.sif*

Type MINT LABEL file (?) :

Type the name of the label file to be used in the conversion, eg, *plan.lab*

The label file is created and you are returned to the main menu.

## File conversion

Type 1 or 2 depending upon the conversion you require, eg, 2.

Type MINT LABEL file (?) :

Type the name of the label file to be used in the conversion, eg, *plan.lab*

Type SIF filename ... (?) :

Type the name of the file to be converted, eg, *plan.sif*

Type GENIO filename (?) :

Type the name of the GENIO file to be created, eg, *plan.crd*

Type chord to arc tolerance ..... (?/Q) [10]  
:

Type the chord to arc tolerance to be used when generating strings which represent curves. This value determines the number of points which are created on the string, with larger values producing less points on the string.

In order to reproduce elements such as cadastral symbols correctly, a smaller chord to arc tolerance should be specified.

Type curvefit method (1)MOSS, (2)SPLINE (?/Q) [1]  
:

Type the curve fit method to be used when creating arcs, eg , 1

Type X coordinate shift ... (Q/?) [0.0] :

Type the value by which you wish to shift each X coordinate in the SIF file.

A coordinate shift can be used to input negative coordinates from SIF to MOSS. However, the shift you apply here should be identical to the shift stored in the parameter file, in order that coordinates read from the MOSS model file may have the shift reversed.

Type Y coordinate shift ... (Q/?) [0.0] :

Type the value by which you wish to shift each Y coordinate in the SIF file.

Do you want EXACT (LS,LT,LC) match .. (Y/N/?/Q) [Y]  
:

Type *y* if you only want strings which have the same line type, style and colour as indicated in the label file to be transferred.  
Type *n* if an exact match is not required.

Processing : SIF

Generating plan.dat

The GENIO file is created and you are returned to the main menu.

Type *0* to exit the program.

MINT program finished.

## Output

The program creates two files, a GENIO file (.crd) and a commentary file (.dat) which contains diagnostics data.

The commentary file contains various statistics concerning the SIF to MOSS conversion and shows any data which has not been transferred.

## Example

### Data file (.dat)

SIF/MINT diagnostics file.

-----

File used : plan.sif

File created : plan.crd

Chord to arc tolerance used : 0.100

Curve fit method : MOSS

Points have not been transformed.

X coordinate shift : 0.0

X\_OSHIFT in your parameter file should be set to :  
0.0

Y coordinate shift : 0.0

Y\_OSHIFT in your parameter file should be set to :  
0.0

ENTITY TYPE	NUMBER USED	NUMBER IGNORED
LST	451	0
LAC	340	0
OVR	130	0
SYM	108	0
TLC	32	0
TXT	32	0
CUR	83	0
ARC	9	0
FNT	0	2
TPC	0	8
PAR	0	8
PLN	0	16
CLP	0	8
INC	0	19

## Program MSDAMS

MSDAMS is a standalone program which converts DA format 001 to MOSS GENIO format. This allows MOSS to label strings automatically as they are entered via GENIO.

### DA format 001

#### Full format

DA format 001 describes points and lines in a file containing records of 80 characters. Each record describes a single point and comprises 18 fields as shown in Table 14 -6.

Field	Description	Column		Data type
		From	To	
1*	Format type	1	3	I3
2	Coordinates code	4	4	
3	Not used	5	5	
4*	Point name	6	19	A2,2A4,I4
5*	Easting	20	31	F12.3
6*	Northing	32	43	F12.3
7	Level code	44	44	
8*	Level	45	52	F12.3
9*	Line number	53	56	I4
10	Line type	57	57	
11*	Line shape	58	58	I1
12	Connection/link type	59	59	



13	Area/fill assignments	60	60	
14	Point type	61	61	
15	Surface	62	62	
16*	Point description	63	64	I2
17*	Line description	65	66	I2
18	Not used	67	80	

**Table 14 -6 DA format 001 record fields**

An asterisk (\*) is used to denote the fields used by MSDAMS to create GENIO data. In the 'Data type' column, the letters I, A and F indicate the type of data and the digits indicate the length. For example:

- I4            4 digit integer
- A2            2 character text string
- F12.3        12 digit real number, including 3 decimal places

**Simplified format**

Simplified DA format 001 contains only the final four characters of the point name (the observation number) easting, northing and level. Only one string is generated from the data and this is a 4D observation string.

A DA format file is assumed to have simplified format if no line number is found.

**Format type**

The format type indicates that the file is a DA format 001 file.

**Point name**

The last 4 digits of this field are translated into the observation number of the point.

**Easting, northing and level**

These values are transferred directly into the GENIO file as X, Y and Z coordinates. Zero levels in the DA format file are interpreted as null levels in MOSS.

**Line number**

The line number indicates which points are connected to form strings. Records having the same line number describe points in the same string.

## Line shape

The line shape is a code indicating whether the associated string is open or closed:

- |   |   |
|---|---|
| 0 | Open string. A MOSS 3D string is created.   |
| 1 | Closed string. A MOSS boundary string is created with the last point coincident with the first.         |
| 2 | Closed box. A MOSS boundary string is created with the fourth and fifth points automatically generated. |

## Point description

The point description defines the partial string label used when creating MOSS point strings. A point string is only created if the line description is 0.

A point description of 1 is a survey station and so a 4D survey station string with the label PSSA is generated.

To determine the actual string label used for each point description, refer to Table 14 -7.

For example, if the point description is 52 (a concrete lamp post) then a string label of P520 would be used.

## Line description

The line description defines the partial string label used when creating 3D or boundary strings. If the line description is 0, a point string is created and the point description is used to determine the partial string label.

To determine the actual string label used for each line description, refer to Table 14 -7. This gives the partial string label used for each line description. The remainder of the label is determined by incrementing the previous string label of the same partial label. If the line number remains the same for subsequent records in the file, these points are added to the same string.

For example, if the line description is 79 ( a fence line), then a partial string label of Z is used.

If this is the first string of this partial label, then the resulting string label is Z001.

If there is already a string with the label Z00A, then the resulting string label is Z00B.

Until the line number changes, all further points are appended to the string.

**The following table to be translated into English from the German provided. Some terms are given in the Project Specification 259/06 DA Format 001 to MOSS GENIO Format.**

Point/Line Description		Description	Partial Label
P	1	Trigon.Pkt	PSSA
P	2	Lagefestpkt	P020
P	3	Höhenfestpkt	P030
P	4	Höhenhilfpkt	P040
P	5	Grenzpkt	P050
P	6	Geländepkt	P060
P	7	Nordpfeil	P070
P L	8 8	Gebaeudepkt.	P080 B
P	9	Stütze (Metall, eckig)	P090
P	10	Schacht (rund)	P100
P	11	Schacht (eckig)	P110
P	12	Schieber	P120
P	13	Unterflurhydr.	P130
P	14	Oberflurhydr.	P140
P	15	Brunnen	P150
P	16	Pumpe (Hand)	P160
P	17	Pumpe (Motor)	P170
P	18	Gulli	P180
P	19	Straßeneinl.	P190
P L	20 20	Grabensohle (trocken)	P200 WT
P L	21 21	Grabensohle (naß)	P210 WN
P L	22 22	Uferlinien. Grabenunterkante naß	P220 WL
P L	23 23	Grabenunterkante-trocken	P230 WU
P L	24 24	Grabenoberkante	P240 WO
P	25	Wasserspiegel (Wa. Höhe)	P250
P	26	Fließpfeil	P260
P	27	Wasserspiegel (Symbol)	P270
P	28	Durchlaß	P280
P	29	Stütze (Metall, rund)	P290
P	30	Schieber (Gas)	P300
P	31	Merkstein (Gas)	P310
P	32	Gas/Wassertopf	P320
P	33	Stütze (allg., eckig)	P330
P	34	Stütze (allg., rund)	P340
P	35	Pkt., ohne Darstellung	P35

P	36	Hofpkt.,Punktbefestigungsart	P360
L	36		D
P	37	Hofpkt. ohne Höhe	P370
P	38	Treppenpfeil, klein	P380
P	39	Treppenpfeil, groß	P390
P	40	Holzmast	P400
P	41	Stahlbetonmast	P410
P	42	Stahlrohrmast	P420
P	43	Stahlgittermast	P430
P	44	Stahlgittermast mit Fundam.	P440
P	45	A-Mast	P450
P	46	Kuppelmast (Holz)	P460
P	47	Kuppelmast (Stahlbeton)	P470
P	48	Holzmast mit Fuß	P480
P	49	Holzmast mit Anker	P490
P	50	Holzmast mit Stütze	P500
P	51	Holzmast mit Lampe	P510
P	52	Stahlbetonmast mit Lampe	P520
P	53	Stahlrohrmast mit Lampe	P530
P	54	Schaltschrank (E)	P540
P	58	Lichtschacht	P58
P	59	Durchfahrt, Überdachungspkt.	P590
L	59		D
P	60	Grünland	F
L	60		F
P	61	Gartenland	F
L	60		F
P	62	Übstanlage	F
L	60		F
P	63	Sport- u. Erholungsflächen	F
L	60		F
P	64	Gebüschfläche	F
L	60		F
P	65	Laubwald	F
L	60		F
P	66	Nadelwald	F
L	60		F
P	67	Mischwald	F
L	60		F
P	68	Ödland	F
L	60		F
P	69	Grünland, einzeln	P690
P	70	Schieber (allgem.)	P700
P	71	Merkstein (allgem.)	P710

P	72	Merkstein (D. Post)	P720
P	73	Gartenland, einzeln	P730
P	74	Laubwald, einzeln	P740
P	75	Laubwald, Kreis	P750
P	76	Sport- u. Erholungsflächen, einzeln	P760
P	77	Laubbaum, aufgem.	P770
P	78	Nadelbaum, aufgem.	P780
P L	79 79	Zaunpkt. m. Höhe	Z
P	80	Verkehrssch. (unbeleucht.)	P800
P	81	Verkehrssch. (beleucht.)	P810
P	82	Verkehrssampel	P820
P	83	Kilometerstein	P830
P L	84 84	Straßenpkt. mit Höhe	P840 L
P L	85 85	Wegpkt. mit Höhe	P850 L
P L	86 86	Befest. artentrennung m. Höhe	P860 T
P	87	Pkt ohne Höhe	P870
P L	88 88	Gleis	P880 E
P	90	Wegweiser	P900
P L	91 91	Mauerpkt., freistehend	P910 A
P	92	Einzelgebüsch	P920
P L	93	Stützmauerpkt.	P930 S
P L	94 94	Heckenpkt.	P940 H
P L	95 95	Pkt. Baumreihe	P95 R
P L	96 96	Nutzungsartenpkt.	P960 N
P L	97 97	Böschungsoberkante	P970 O
P L	98 98	Böschungs-Uk	P980 U
P L	99 99	Zaunpkt. o. Höhe	P990 Z

**Table 14 -7 Generated partial string labels**

## Running the program

At the operating system prompt:

Type MSDAMS

You are presented with a start up message followed by the prompt:

Type either - The name of the DA format file to be converted

or - FINISH to end procedure

Type the name of the file to be converted, for example, *dadesign.d01*

Type the required modelname

Type the name of the model in which you wish to store the data, for example, *dadesign model*.

Type the required method of interpretation (1 or 2)

Type 1 or 2 depending upon the method of interpretation you require.

The method of interpretation is used when records in the file have the same line number but different line descriptions.

Method 1 interprets the records as a list of points in the same string whose string label is derived from the line description of the first point.

Method 2 creates a new string label each time a new line description is encountered.

```
dadesign.d01
```

```
has been converted to MOSS GENIO file d01.crd
```

The first prompt is then redisplayed so that you may process another file or end the procedure.

## Output

The program creates two files, a GENIO file (d01.crd) and an error file (.err) which contains diagnostics data.

The GENIO file contains three commented out lines for the model you specified when running the program. These lines use major options DELETE, CREATE and GENIO to ensure that an existing model of the same name is overwritten. Remove the spaces at the beginning of these lines if you wish this to happen.

The error file contains various statistics concerning the DA format to MOSS conversion and shows any data which has not been transferred.

## Program MSSHOW

MSSHOW is a standalone program which allows you to display CGAL frames. You can display either a single frame or several frames in a timed sequence.

MSSHOW can also be used to display views produced by MOSS and stored as bitmap files.

### EPIC frame files

Frames produced by EPIC are held in files which have names of the form *pn.f*, where 'p' is the hardware platform, 'n' is the frame number in the range 0000001 to 1000000 and '.f' is the file name extension. If you do not use a data file, the frames are shown in sequence and should be numbered consecutively.

### MSSHOW data files

A data file is a text file containing a list of EPIC frame file names to be displayed in a MSSHOW sequence. A data file is only required if you wish to display more than one frame and your frames do not have consecutive numbers. The file name extension '.shd' should be used for an EPIC data file.

File names within the data file must be written with the file name extension and may be prefixed by a path name if your EPIC frames are held in another directory. For example, a data file named 'patterns.shd' might contain the following:

```
frames/sun00001008.f
frames/sun00001009.f
frames/sun00001015.f
frames/sun00001016.f
frames/sun00001017.f
```

### Running the program

#### Without a data file

At the operating system prompt:

Type *MSSHOW*

A version and licence message is displayed followed by:

Load a data file (Type Y, N or FINISH to exit):

Type *N*

Type the start frame number (1-1000000):

Type 1

Type the number of frames to display (1-1000):

Type 1

Type the delay in seconds between each frame (0-600):

Type 10

Number of shows (1-1000, or L for continuous display):

Type 1

### With a data file

At the operating system prompt:

Type *MSSHOW*

A version and licence message is displayed followed by:

Load a data file (Type Y, N or FINISH to exit):

Type Y

Enter data file name:

Type the name of the data file you wish to use, for example, *patterns.shd*.

The data file should contain the names of all the frames you wish to view. If your data file is held in another directory, specify the full pathname.

Type the delay in seconds between each frame (0-600):

Type 10

Number of shows (1-1000, or L for continuous display):

Type 1

MSSHOW will now display each frame named in the data file for 10 seconds.

### MSSHOW commands

While the frame or frame sequence is being displayed, you may type the following commands:

**P** – pause

Pauses the screen so that the current frame is displayed until another command is entered.



**Q** – quit

Quits MSSHOW.

While in 'Pause' mode the following commands may be used:

**C** – continue

Continues with displaying the frames in a timed sequence.

**F** – forward to the next frame

Displays the next frame.

**B** – backwards to the previous frame

Displays the previous frame.

**Q** – quit

Quits MSSHOW.

## Program MSDOCUMENT

MSDOCUMENT provides access to the online MOSS document set.

Documents may be viewed, interrogated, marked with notes or bookmarks, and printed.

### Running the program

At the operating system prompt:

Type *MSDOCUMENT*

On entry to MSDOCUMENT, a document window is opened and you are presented with a list of the available documents with adjacent buttons. To select a document for viewing, double-click with the left hand mouse button on the appropriate document button.

The document window has a menu bar across the top. For full details of the facilities available in MSDOCUMENT and how to use them, select 'Help' from the menu bar.

## Program MSCRMENU

### Introduction

The MOSS Menu Builder is a stand alone program with a Motif Look and Feel.

The MOSS Menu Builder will run in an X windows environment.

The primary purpose of the MOSS Menu Builder is to allow UPMs to make use of the MOSS IG mode. The menus created by the MOSS

Menu Builder will be linked to the UPM that uses them by their group name. The UPM will display the menus in the MOSS IG mode scrolling menu area.

The content of the menu field may be either text or a macrosymbol icon.

Help may be associated with each menu. Simple techniques are used to enter the help information which may be either text or graphic.

Within a menu group two types of menu may be created -

- Choice type menu
- Datatype menu

A choice type menu allows selection of a single option from those displayed. The menu is equivalent to the MOSS minor option menu and has no data input. The return value from a choice menu will indicate to the UPM which selection has been made.

A datatype menu accepts MOSS data. This data will be used by the UPM to construct MOSS minor option data to be passed to MOSS. The following data types are accepted -

- Text - Keyboard
- Integer - Keyboard
- Real - Keyboard
- 2D - PSM
- 3D - PSM
- Point Number
- Chainage
- Distance - Keyboard
- Bearing - Keyboard
- String Model - MSM
- Triang Model - MSM
- String - Keyboard or Cursor
- Toggle
- Real - Information only
- Integer - Information only
- Text - Information only
- XY - CMS

On entry to the Menu Builder four selection are available from the MenuBar. The choices are - File, Edit, Help and Finish.

**File**

The file options allow you to carry out the following file manipulations -

- Create a new group of menus
- Reload an existing group of menus
- Save a group of menus.

**Edit**

The edit options allow you to make changes to an existing group of menus. The selections are -

- Delete a menu
- Delete a menu field
- Insert a new menu field
- Move a menu field
- Swap two menu fields.

**Help**

This option provides help on the Menu Builder program, and allows you to create help for the current menu group. The help created for the current menu may be in any of the following styles -

- Help from Major option DOCUMENT
- Graphical
- Text.

**Finish**

This option exits the MOSS Menu Builder.

**File - New**

This option is used to begin creating a new group of menus. You will be asked to supply menu group name, reference and an associated group of macrosymbols.

**File - Open**

This option is used to open an existing group of menus to enhance, extend or edit the group.

**File - Save**

This option is used to save the current group of menus, using their assigned filename.

**File - Save as**

This option is used to save the current group of menus and specify their filename.

- ◇ Both options **Save** and **Save as** save the current menu group to file, and create the files required by the UPM.

**Edit - Delete menu**

This option is used to delete a menu, and all its associated information from the current menu group.

**Edit - Delete field**

This option is used to delete a field, and all its associated information from the current menu.

**Edit - Insert new field**

This option is used to insert a new field into the current menu. You will be asked to indicate the position of the field to insert.

**Edit - Move field**

This option is used to move a field in the current menu. You will be asked to indicate the field to move, and its new position.

**Edit - Swap two fields**

This option is used to swap two field in the current menu. You will be asked to indicate the two fields to be swapped.

**Help - Help on Help**

This option will take you to the information on operating and setting up major option DOCUMENT.

**Help - Help on Menu Builder**

This option will take you directly to this document within major option DOCUMENT.

**Help - Create/Edit help for menu**

This option allows you to create or specify the help to be provided for the user of the UPM. The help is attached to the menu and should provide sufficient information to guide the user to help him complete the menu. The help may be either, text, graphic or use WorldView.

Text will allow you to create a display panel containing a maximum of 256 words of ASCII text. Graphic will allow you to specify a .dpf file to be displayed in a panel. WorldView will allow you to specify a filename by which the in-context help is identified.

## Finish

This is the standard MOSS option Finish. As there is no database behind MSCRMENU no data has been saved to disk unless a positive save has been carried out.

If the current menu group has changed since the last save, a warning is issued to give you the opportunity to cancel the finish and save the changes.

## Glossary

### Datatype

The type of data expected from the user as input for this field.

### Field

A field is a single box within a menu. The field may present one of a maximum of ten choices, or request one of a maximum of ten items of data. Choice and Data fields cannot be used in the same menu.

Each field of a choice menu may have the following attributes -

- Description - the text to be used in the field
- Field Return Value - the value to be used by the UPM to determine the next action.

Each field of a data menu may have the following attributes -

- Description — the text to be used in the field
- Datatype
- Prompt - text provided to guide the user
- Variable name - the UPM variable to which the data entered is to be assigned. The variable specified will automatically have a g-prefix added to it to make it a UPM global variable.
- Field type - a setting which determines the field behaviour.

### Fieldtype

Fieldtype allows you to determine the behaviour of the field when used in the UPM. Four options are available -

**Optional** This setting can only be used where the data to be obtained for the UPM variable is not essential, or will be supplied by a default value within the UPM.

When used with the UPM, the default value will be displayed in the field, giving the user the option to change it.

**Auto highlight** This setting means that the field will be highlighted when data entry is required.

**Mandatory & Auto highlight** This setting means that the field will be auto highlight when data entry is required, and the user cannot move on until the data requirement is satisfied.

**Auto-Proceed** This setting means that when the user has entered the data required, the UPM will take control and process the data entered into the menu.

### **Group Name**

The name given to your group of menus and the name by which your IGUPM will gain access to these menus.

### **Group Reference**

A three character reference code for your group of UPM menus.

### **Group Macro symbol**

A user defined MOSS macro symbol which will appear in the bottom left hand corner of the IGUPM screen.

### **Macrosymbol icon**

A user defined symbol used to describe the input required. The symbol is an alternative to text.

### **Menu**

A menu is a set of a maximum of ten choices or a maximum of ten items of data for input and passing to the UPM.

Each menu has the following attributes -

- Menu group - a seven character name used by the UPM to identify the menus required for IG mode.
- Menu reference - a combination of three alpha characters used within the menu files in combination with menu numbers to identify individual menu lines.
- Menu logo - a graphic used in the lower left hand corner of the IGUPM screen to brand the UPM.
- Menu number - a number between 001 and 999. May be used to select a menu to be edited
- Menu title - the text entered will be used at the top of the menu
- Menu prompt - the text entered will be displayed in the MOSS IG prompt area when the menu is first displayed.
- Menu type - this may be switched between Choice and Data.

**MSM**

Model Selection Method - allows the user to use any of the current MOSS Model Selection Methods to provide the data for the field.

Current methods are -

- Type the model name
- List model names and select from the list.

# MIFILE

## Introduction

This document defines the basic structure and minimum content of the MOSS Intermediate Graphics File format (MIF). The file is produced from a MOSS DRAW PICTURE FILE. ( DPF)

The generated file is a card image file interpretation of the DPF and may be accessed by other complementary computer graphics programs. It is intended that a complementary program suite can provide a feature which reads the MOSS Intermediate File (MIF) and generates its own graphical database from the information supplied.

To assist with the interfacing to other systems with the MIF a pack is available from MOSS Systems Limited (MSL), containing:

- Documentation of the MIF (this document).
- Test card image files on suitable magnetic media.
- Sample plots of the test files.

The maintenance and update of the intermediate file will be carried out by MOSS Systems Ltd.

All registered holders of this manual will be notified of the changes made to the MOSS preprocessor and the intermediate file format. Any new information added to global information entries or drawing entities may be ignored until software changes are implemented.

## File format

The intermediate file is produced in a file format which is a sequential ASCII text file, 80 characters per record.

The file is easily readable both by eye and machine. Data is specified in fields of twelve characters, six fields per line. Each field is separated by a space.

An end of record marker is placed in the 80th column to enable format checking.

Consideration has also been given to extending records and adding new entities in the future.



**File structure**

The MOSS Intermediate File is split into three parts:

- Global Information Entries.
- Group Entries.
- Drawing Entities.

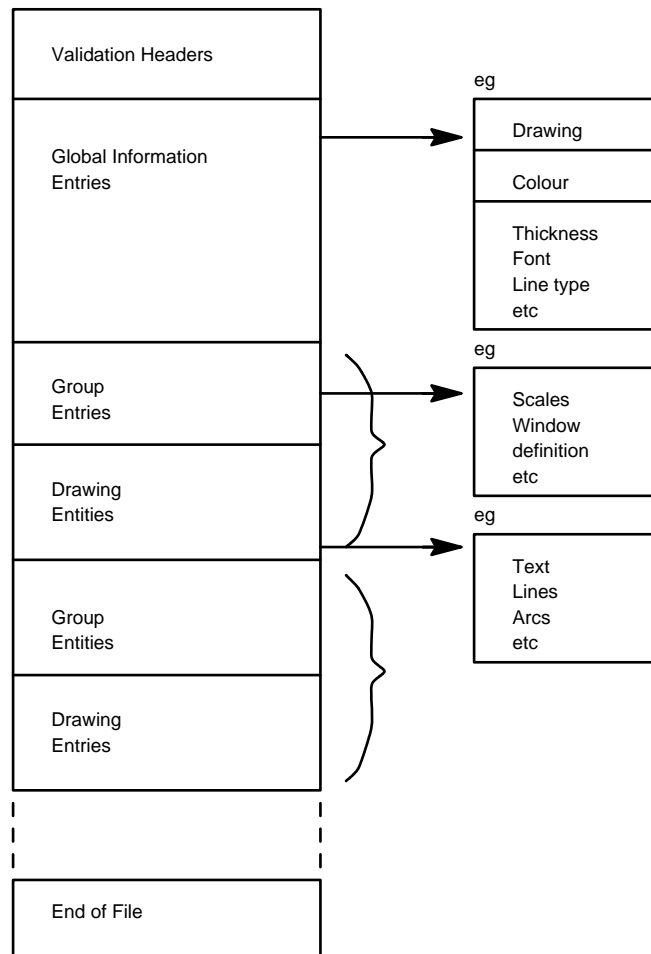
**Global Information Entries** give information about the complete drawing. Typical information given is validation data, colour definitions and font information.

**Group Entries** - Within a total drawing there may be 'groups' of drawing information. For example a drawing may be a composite containing a plan drawing, cross sections and a perspective view. For each 'group' information is given relating to scales and model definitions. A 'group entry' occurs before each set of drawing entities relating to it.

**Drawing Entities** - all the various drawing components, eg lines, arcs, text, etc are contained within drawing entities.

The file contains information entries (either global or group) and drawing entities. Each entry and entity has its own format (see later sections). The order in which information entries and drawing entities appear is shown in the diagram.

A set of validation headers appears first. This defines the file as a MOSS intermediate format file, and give information relating to the date of generation and the version of MOSS under which it was created.



The global information entries are referenced by subsequent entities in the file.

The global information entries are in the order shown. They only appear once in the file. The length of each information entry will vary for the amount of drawing information in the intermediate file.

The group entries and drawing entities appear after the global information entries. Some entities may be groups of other drawing entities.

The end of file is marked by an EOF marker. To aid verification of file transfer a marker is always placed in the 80th column. To ensure the correct number of records have been read a total number of records is given at the end of the file.

## Summary of Intermediate File

### File format:

Sequential, 80 character card image. (ASCII)

Real numbers are written to FORTRAN IV F12.5 format.

Integer numbers are written to FORTRAN IV I12 format.

The end of record mark is an X in the 80th column.

The end of file marker is EOF.

The total number of records is written after the EOF marker.

### File order:

As defined in File Structure

### Data format:

12 characters per field

6 fields per line

Each field is separated by a space

All characters are right justified in the field

Character set as defined in Appendix B.

### Drawing entities

Text

Polyline

Symbol and Centred

Vector

Hatch

Arc

### Group entries

SheetWindow

Model

Object

Element

### Information identifiers

MIFHEADER-		General file information	
DRAW	-	drawing	}
COLOUR	-	colour	}
THICK	-	thickness	}
FONT	-	font	} Information
LTYPE	-	line type	}
MSYMBL	-	symbol	}

CFTYPE - curve fitting }  
types }

**Group identifiers**

SHEET  
WINDOW  
MODEL  
OBJECT  
ELEMENT

**Entity identifiers**

TEXT - text }  
POLYLINE - lines }  
SYMBOL and  
CENTRED - symbol } Entity  
VECTOR - vectors }  
HATCH - hatch }  
ARC - arc }

**General**

The information record and entity terminator is END<identifier name> eg ENDDRAW, ENDPOLYLINE

**Global Information Entries****Introduction**

The first section of the intermediate file holds global information entries. These entries contain information relating to the drawing page and the drawing entities.

**Validation headers**

The first entry in the intermediate file is the validation header. This allows the file to be checked that it is a MOSS intermediate format file.

Header Contents

Field	Type	Description
1	String	'MOSS
2	String	INTERMEDIATE
3	String	FILE'

MIF Header Record Contents

Field	Type	Description
1	String	'MIFHEADER'
2	String	Date MIF created
3	String	Time MIF created
4	Integer	Vector details flag:- 0 = Omit vectors for all entities 1 = Include vectors for all entities MOSS DPF name used
5	String	

### Example

```

MOSS INTERMEDIATE      FILE      X
MIFHEADER      29JUN89      16:32:11      1 MIFSAMD.DPF      X

```

### Drawing information

The drawing information entry refers to the MOSS drawing size and the MOSS system creating the intermediate file.

The level of the MOSS system refers to the level and revision of the system used to create the drawing picture.

The revision of the MOSS pre-processor refers to the actual pre-processor used to create the intermediate format file.

The drawing units flags sets the drawing units to be used throughout the intermediate file.

The number of sheets of drawing on the DPF.

◇ *This is not necessarily the number of sheets converted and stored on the MIF.*

The drawing size is described by the sheet length in the x and y direction. The dimensions are drawing units.

The drawing information terminator defines the end of the drawing information entry.

Field	Type	Description
1	String	DRAW Identifier
2	Integer	Length of next string
3	String	Version Number
4	Real	Revision of MOSS post processor
5	Real	MIF Revision number
6	Integer	Drawing units flag (1 = mm, 2 = cm)
7	Integer	Number of sheets on the DPF used to create this MIF
8	String	'ENDDRAW' information terminator

### Example

```

DRAW      4      V8.0      8.00000      1.50000      2
X

```

**Colour information**

The colour information entry contains data that is referenced from entities via their colour indices. As each entity is drawn its colour is specified by its colour

index and this colour index is cross referenced to the colour information entry to determine its definition.

Colours are made up from the primary colours of red, green and blue which are described as a proportion of full density.

Field	Type	Description
1	String	'COLOUR' Information Identifier
2	Integer	Number of colour Indices N
3 - 6	-	Blank
7	Integer	Colour Index 1
8	Real	Red - amount (0-1.0)
9	Real	Green - amount (0-1.0)
10	Real	Blue - amount (0-1.0)
11	Integer	Length of colour name
12	String	Colour name
:	:	:
1+6*N	integer	Colour Index N
:	:	:
7+6*N	String	'ENDCOLOUR' Information Terminator

**Example**

```

COLOUR
1 1.00000 1.00000 1.00000 5 BLACK X
2 0.10000 1.00000 0.10000 5 GREEN X
3 1.00000 0.10000 0.10000 3 RED X
4 0.00000 1.00000 1.00000 4 CYAN X
5 0.20000 0.20000 0.9000 4 BLUE X
ENDCOLOUR

```

**Thickness information**

The thickness information entry contains data that is referenced from entities via their thickness indices.

The thickness is expressed in drawing units.

Field	Type	Description
1	String	'THICK' Information Identifier
2	Integer	Number of thickness indices N
3 - 6	-	Blank
7	Integer	Thickness Index 1
8	Real	Thickness in drawing units
9 - 12	-	Blank
: 1+6*N	: Integer	: Thickness Index N

: 7+6\*N : String : 'ENDTHICK' Information Terminator

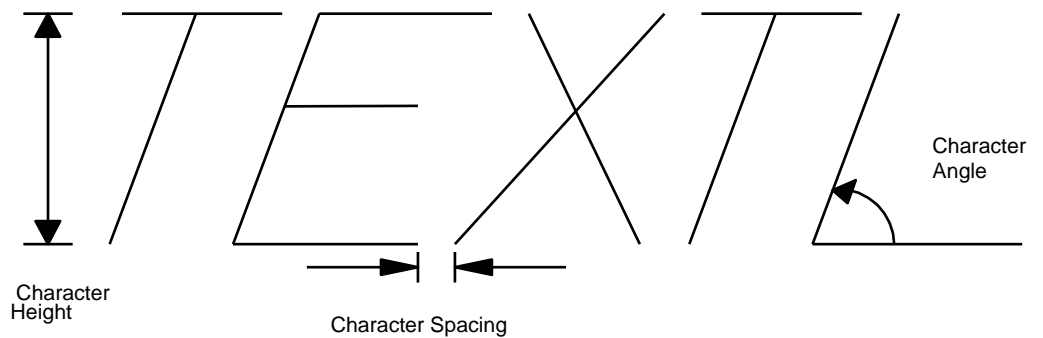
Example

```

THICK          1
 1             0.03000
ENDTHICK
X
X
X
    
```

Font information

The font information contains data that is referenced from entities via their font indices. The character height, spacing and angle are shown in the following diagram.



Field	Type	Description
1	String	'FONT' Information Identifier
2	Integer	Number of Font Indices N
3 - 6	-	Blank
7	Integer	Font Index 1
8	Integer	Number of characters in style name
9	String	MOSS text style name
10	Integer	Number of characters in font name
11	String	Font name
12	Real	Character height in drawing units
13	Real	Height/Width Ratio
14	Real	Character spacing in drawing units
15	Real	Character angle
16	Real	Character thickness
17	Integer	Number of decimal places
:	:	:
7+12*(N-1)	Integer	Font Index N
:	:	:
19+12*(N-1)	String	'ENDFONT' Information Terminator

Example

```

FONT          3
 1             4             MOSS          4             MOSS          0.18000
1.00000      0.00000  0.00000      0.10000      3             X
X
X
    
```



```

                2
0.70000         4      NOTE          4      MOSS      0.50000X
                3
0.85000         4      NAME          4      MOSS      0.50000X
ENDFONT        0.00000 0.00000      0.10000  3
                4
                4      MOSS          3
                3
                X
                X
    
```

### Line type information

The line type information entry contains data that is referenced from entities via their line type indices.

There are three methods for producing Line Types in MOSS; preset (hardware), four element dash and macro line. For the purposes of the MIF they are split into two groups:

- **MOSS** - preset (hardware). The preset line types can be solid, dashed, dotted and dash/dot.
- **USER** - four element dash and macro line. The four element dash line is redefined as a macroline type.

The MOSS line types are referenced by a flag indicating which line style is to be used.

The USER line types are defined using the full macro definition as used in MOSS and described in the MOSS User Manual.

Macrolines are defined giving distance along and offset from a straight line. For each point defined the position of the drawing pen, whether up or down, when moving to the point must be given. The point (0,0) corresponds to the first point on the element. Scaling of the length of the macro lines pattern is achieved at the time of use by either stretching between consecutive points or by repeating the pattern. The width of the pattern may also be defined at the time of use.

The first point defined (with status 3 ie pen up) must be an initialising coordinate and is used when the macro line is first entered. Repetition occurs from the second point only. A terminator coordinate of (-1,-1,-1) is required to terminate the macro line or to terminate a single line within a multi line macro line.

Field	Type	Description
1	String	'LTYPE' Information Identifier
2	Integer	Number of Line Type Indices N
3 - 6	-	Blank
7	Integer	Line Type Index 1
8	Integer	Line Type Group (1 = MOSS, 2 = user macro, 3 = user dashed)

If a **MOSS** line type group:

Field	Type	Description
-------	------	-------------

---

9	Integer	Hardware line type (1 = solid, 2 = dashed, 3 = dotted, 4 = dash/dot)
10 - 12	-	Blank
If a <b>USER</b> line type group:		
Field	Type	Description
9	Integer	Number of characters in name
10	String	Line type name
11	Integer	Number of separate lines in USER definition.
12	-	Blank
13 - 15	Integer	First point in USER definition
13	Integer	Distance along base line to point (Length) (cms x 100) for dashed lines/or offset for other lines
14	Integer	Offset from base line to point (Height) (cms x 100) for dashed lines/or offset for other lines
15	Integer	Pen status = 2 if the pen is down when moving to this point.= 3 if the pen is up when moving to this point.
16 - 18	Integer	Second point in definition as above. (See fields 13-15)
:	:	:
		Last point in definition as above. (See fields 13-15)
	Integer	-1
	Integer	-1
	Integer	-1

Example

LTYPE							9
X							
1			1				1
X							
2	3		6	DASH01			1
X							
0	0		3	150			0
X							
175	0	3	200	0			2
X							
225	0	3	-1	-1			-1
X							
3	2	5	HEDGE	3			0
X							
0	2	3	2	4			2
X							
10	4	2	12	2			2
X							
14	4	2	22	4			2
X							
24	2	2	26	4			2
X							
34	4	2	36	2			2
X							
-1	-1	-1	0	0			3
X							
30	0	2	32	0			3
X							
34	0	2	36	0			3
X							
-1	-1	-1	0	-4			3
X							
4	-4	2	6	-2			2
X							
8	-4	2	16	-4			2
X							
18	-2	2	20	-4			2
X							
28	-4	2	30	-2			2
X							
32	-4	2	36	-4			2
X							
-1			-1				-1
X							
4	3		6	DASH02			1
X							
0	0	3	75	0			2
X							
99	6	3	100	-6			2
X							
125	0	3	-1	-1			-1
X							
5	3		6	DASH03			1
X							
0	0	3	100	0			2
X							
200	0	3	300	0			2
X							
400	0	3	-1	-1			-1
X							
6	3		6	DASH04			1
X							
0	0	3	100	0			2
X							
199	50	3	200	-50			2
X							
300	0	3	-1	-1			-1
X							
7	3		6	DASH05			1
X							
0	0	3	100	0			2
X							
164	35	3	235	-35			2
X							
300	0	3	-1	-1			-1
X							
8	3		6	DASH06			1

X						
0	0	3	100	0	2	
X						
235	35	3	164	-35	2	
X						
300	0	3	-1	-1	-1	
X						
9	2	7	TADPOLE	1	0	
X						
0	0	3	35	0	2	
X						
39	1	2	43	2	2	
X						
47	3	2	55	7	2	
X						
80	23	2	82	24	2	
X						
85	25	2	86	25	2	
X						
88	24	2	89	23	2	
X						
90	22	2	92	19	2	
X						
94	14	2	95	11	2	
X						
96	7	2	97	0	2	
X						
96	-7	2	95	-11	2	
X						
94	-14	2	92	-19	2	
X						
90	-22	2	89	-23	2	
X						
88	-24	2	86	-25	2	
X						
85	-25	2	82	-24	2	
X						
80	-23	2	55	-7	2	
X						
47	-3	2	43	-2	2	
X						
39	-1	2	35	0	2	
X						
-1			-1		-1	
X						
ENDLTYPE						
X						

## Symbol information

The symbol information entry contains data that is referenced from entities via their symbol indices.

There are two types of symbols used in MOSS; user definable macro symbols and machine dependent standard symbols.

'Standard' symbols are redefined as user defined macro symbols within the entry. User defined macro symbols are defined using the full macro definition as used in MOSS and described in the MOSS User Manual

Macro symbols are defined by giving distance along and offset from a straight line. For each point defined the position of the drawing pen, whether up or down, when moving to the point. The point (0,0) corresponds to the point defined. Scaling of the macro symbol is achieved by defining the height and width of the symbol at the time of use.

A terminator coordinate (-1,-1,-1) is given at the end of the macro symbol.

Field	Type	Description
1	String	'MSYMBL' Information Identifier
2	Integer	Number of Symbol Indices N
3 - 6	-	Blank
7	Integer	Symbol Index 1
8	Integer	Symbol type (1 = Centred, 2 = Macro)
9	Integer	Number of characters in name
10	String	Symbol name
11	Integer	Number of separate lines in symbol definition
12	Integer	Number of Ref points
13 - 15	Integer	First point in USER definition
13	integer	distance along base line to point (Length) (in the range -99 to +99)
14	Integer	Offset from base line to point (Height) (in the range -99 to +99)
15	Integer	Pen status = 2 if the pen is down when moving to this point. = 3 if the pen is up when moving to this point.
16 - 18	Integer	Second point in definition as above. (See fields 13-15)
:	:	:

Last point in definition as above.

(See fields 13-15)

Symbols with more than one hatching boundary will use -1, -1, -1 as a separator for each element ie northing symbol

Integer -1

Integer -1

Integer -1

Last field used String

'ENDMSYMBL' Information Terminator

Example

MSYMBL	9								X
1	1	9	CENTRED00	1	0	X			
0	0	3	0	50	2	X			
-50	50	2	-50	-50	2	X			
50	-50	2	50	50	2	X			
0	50	2	-1	-1	-1	X			
2	1	9	CENTRED01	1	0	X			
0	0	3	0	50	2	X			
25	50	2	50	25	2	X			
50	-25	2	25	-50	2	X			
-25	-50	2	-50	-25	2	X			
-50	25	2	-25	50	2	X			
0	50	2	-1	-1	-1	X			
3	1	9	CENTRED02	1	0	X			
0	0	3	0	50	2	X			
50	-50	2	-50	-50	2	X			
0	50	2	-1	-1	-1	X			
4	1	9	CENTRED05	1	0	X			
0	0	3	0	50	2	X			
-50	0	2	0	-50	2	X			
50	0	2	0	50	2	X			
-1	-1	-1				X			
5	1	9	CENTRED12	1	0	X			
0	0	3	50	50	2	X			
-50	50	2	50	-50	2	X			
-50	-50	2	0	0	2	X			
-1	-1	-1				X			
6	1	9	CENTRED03	1	0	X			
0	-50	3	0	50	2	X			
-50	0	3	50	0	2	X			
-1	-1	-1				X			
7	2	8	TREESYMB	1	0	X			
-25	0	3	-38	1	2	X			
-50	5	2	-47	18	2	X			
-44	18	2	-45	22	2	X			
-39	32	2	-29	27	2	X			
-18	18	2	-27	29	2	X			
-32	39	2	-22	45	2	X			
-18	44	2	-18	47	2	X			
-5	50	2	-1	38	2	X			
0	25	2	1	38	2	X			
5	50	2	18	47	2	X			
18	44	2	22	45	2	X			
32	39	2	27	29	2	X			
18	18	2	29	27	2	X			
39	32	2	45	22	2	X			
44	18	2	47	18	2	X			
50	5	2	38	1	2	X			
25	0	2	38	-1	2	X			
50	-5	2	47	-18	2	X			
44	-18	2	45	-22	2	X			
39	-32	2	29	-27	2	X			
18	-18	2	27	-29	2	X			
32	-39	2	22	-45	2	X			
18	-44	2	18	-47	2	X			
5	-50	2	1	-38	2	X			
0	-25	2	-1	-38	2	X			
-5	-50	2	-18	-47	2	X			
-18	-44	2	-22	-45	2	X			
-32	-39	2	-27	-29	2	X			
-18	-18	2	-29	-27	2	X			
-39	-32	2	-45	-22	2	X			
-44	-18	2	-47	-18	2	X			
-50	-5	2	-38	-1	2	X			
-25	0	2	-1	-1	-1	X			
9	2	8	NORTHING	2	0	X			
0	0	3	-11	-6	3	X			
-11	2	2	-5	2	2	X			
5	-4	2	5	2	2	X			
11	2	2	11	-6	2	X			

[Contents](#)

[Index](#)

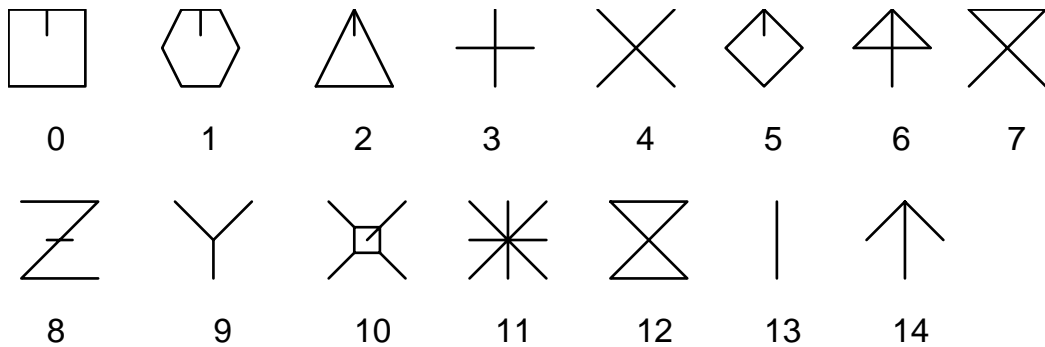
## CHAPTER 14 MIFILE

---

5	-6	2	-5	0	2	X
-5	-6	2	-11	-6	2	X
-1	-1	-1	-11	3	3	X
0	10	2	11	3	2	X
-11	3	2	-1	-1	-1	X
ENDMSYMBL						X



The 'standard' centred symbols are represented as follows:-



### Curve fitting information

The Curve Fitting Information contains details of the number and types of curve fitting used within the drawing.

The curve fitting algorithms are described in Chapter 2. They generate points on the chosen curve such that the chord to arc distance is small enough for the straight line segments between successive points to be a sufficient representation of the curve.

Field	Type	Description
1	String	'CFTYPE' Information identifier
2	Integer	Number of curve fitting types
3 - 6	-	Blank
7	Integer	C.F. Index 1
8	Real	C.F. Tolerance
9	Integer	Length of the Style Type Name
10	String	Style type name
N*6+1	String	'ENDCFTYPE' Information terminator

### Example

```

CFTYPE          2
  1             0.25000
  2             0.25000
ENDCFTYPE
                4          MOSS      X
                4          SPLI      X
                X
    
```

## Group Entries

### Introduction

The group entries are contained within a fixed group structure as follows:

SHEET - WINDOW - MODEL - OBJECT - ELEMENT

A SHEET contains a number of WINDOWS.

A WINDOW contains a number of MODELS.

A MODEL contains a number of OBJECTS.

An OBJECT contains a number of ELEMENTS.

An ELEMENT is the lowest level group identifier and contains the actual Drawing entities, such as LINES, ARCS and TEXT.

### Example

```
SHEET
WINDOW
MODEL
  |
  |
ENDMODEL
ENDWINDOW
WINDOW
MODEL
  |
  |
ENDMODEL
ENDWINDOW
ENDSHEET
```

### SHEET information

Within a drawing file there may be a number of separate sheets which may contain different models and different types of drawing (Plans, sections etc)

Each SHEET is a completely new picture and represents a new sheet of paper if it is to be represented on a plotter.

A SHEET consists of a number of WINDOWS. Each window has its own scale, world coordinate origin etc. Normally PLAN drawings and SECTION drawings contains only one WINDOW per SHEET. Composite drawings contain multiple windows of different pictures which are represented on a single sheet of paper.

Field	Type	Description
1	String	'SHEET' Identifier
2	Integer	Sheet Number
3	Real	X sheet size in drawing units
4	Real	Y sheet size in drawing units
5	Integer	Number of windows within the sheet

Example

```

SHEET      1      45.00000      25.00000      1      X

```

The 'ENDSHEET' information terminator will occur at the end of the group entry.

**WINDOW Information**

The WINDOW entry describes the dimension and shape of the following entities and contains MODELS.

Field	Type	Description
1	String	'WINDOW' Identifier
2	Integer	Sheet Number
3	Integer	Window Number
4	Integer	Type of drawing 1 = Plan 2 = Long section 3 = Cross section
5	Integer	Number of Models in this window
6	-	Blank
7	Real	X window size in drawing units
8	Real	Y window size in drawing units
9	Real	Left margin in drawing units
10	Real	Bottom margin in drawing units
11	Real	Right margin in drawing units
12	Real	Top margin in drawing units
13 & 14	Real	Bottom left X World Coordinate
15 & 16	Real	Bottom left Y World Coordinate
17	Real	Page Rotation (LHS Bearing)(radians)
18	-	Blank
19	Real	Horizontal Back Transformation Scale
20	Real	Vertical Back Transformation Scale
21	Real	Horizontal User Scale
22	Real	Vertical User Scale

Example

```

X      WINDOW      1      1      1      2
X      36.00000      23.00000      1.00000      1.00000      8.00000      1.00000
X      900.00000      900.00000      0.00000
X      10000.00000      10000.00000      10000.00000      10000.00000
X

```

The 'ENDWINDOW' information terminator occurs at the end of the window information.

## MODEL information

The MODEL entry contains model name information and the number of OBJECT entities within this model.

Field	Type	Description
1	String	'MODEL' Identifier
2	Integer	Number of Objects in this Model
3	Integer	Length of Model Name
4 - 6	String	Model Name

### Example

```
X      MODEL                6                17 MIFILE TEST                MODEL
```

The 'ENDMODEL' terminator occurs at the end of the model information.

## OBJECT information

The object entry contains the Object Name details and the number of ELEMENTS within this object.

Field	Type	Description
1	String	'OBJECT' Identifier
2	Integer	Number of elements in the object
3	Integer	Length of Object name
4	String	Object name

### Example

```
X      OBJECT                3                4                . . . .
```

## ELEMENT information

The Element entry contains name information and the MOSS minor option number used to generate the element information on the DRAW major option.

Field	Type	Description
1	String	'ELEMENT' Identifier
2	Integer	MOSS Minor Option Number
3	Integer	Length of Element name
4	String	Element name

### Example

```
X      ELEMENT                821                4                /100
```

The 'ENDELEMENT' terminator occurs at the end of the drawing entities defining the element.

## Drawing Entities

### Introduction

A drawing entity describes the graphical information that appears on a drawing. In MOSS drawings entities are referenced as individual elements or as a collection of elements within an object.

### Elements

Elements contain individual drawing entities. The elements that are dealt with are:

TEXT  
POLYLINE  
ARC  
SYMBOL  
VECTORS  
HATCH  
CENTRED  
PIPMARK

An Element may contain any or all of the entities.

A Symbol entity contains line entities and/or text entities.

A Hatch entity only contains line entities.

### Line and symbol definitions

Line and symbol definitions are specified twice in the intermediate file. The Line Type and Symbol Information Entries contain full macro definition of line types and symbols. In addition, component lines of the line or symbol are included in the entity itself. This allows any system to use the macro definition irrespective of its capabilities to handle symbols or user defined line types. A flag is given in the MIFHEADER to determine the status of vectors in the file.

### Entity format

All entities begin on a new line, whether they appear on their own or in an entity group.

### TEXT entity

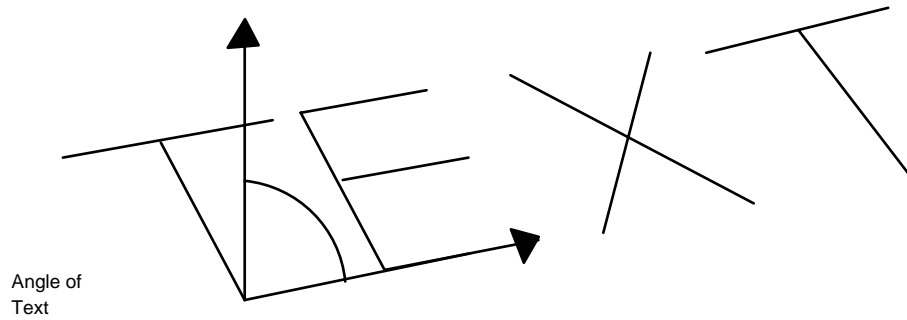
The text entity contains text information and references to Font, Colour and Thickness Information Entries.

The text is from the recognised ASCII character set.

The maximum number of characters is eighty (80).

The text is considered to be left justified from the bottom left corner position defined.

The text angle is measured in radians. It is the baseline angle measured as a whole circle bearing as shown in the following diagram.



Field	Type	Description
1	String	'TEXT' Entity Identifier
2	Integer	Font Index
3	Integer	Colour Index
4	Integer	Thickness Index
5	Real	Bottom left corner
6	Real	Coordinate of text in drawing units
7	Real	Angle of Text in radians
8	Integer	Number of characters
9+	String	Text String
:	:	:
Text height for text string		0.0 for enhanced which uses defined font
Last field used		String 'ENDTEXT' Entity
Terminator		

### Example

```

X      TEXT          2          1          1      37.25000      18.0000
X      1.57080      18 MIFILE SAMPL      E PLOT      0.00000      ENDTEXT
X

```

### POLYLINE entity

The polyline entity contains line information. A line is defined as having two end points. Each end point is defined by an x, y coordinate relative to the drawing origin in drawing units.

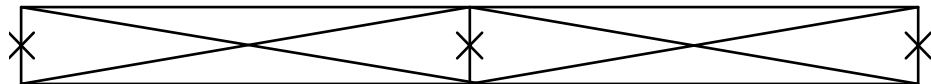
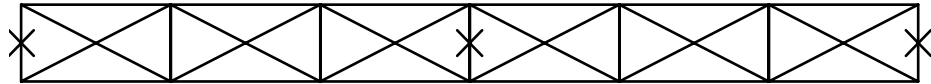
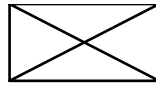
A user-definable line type (four-element dash or macro line) is defined both by its Line Type Index and the component lines that make up that line between the start and end points.

Any line type that is not consistent (ie irregular) should always be defined by its component lines.

The drawn length of pattern determines if a macro line type is drawn stretched or repeated between line and end points, as illustrated in the following diagram.

The depth of pattern defines the width of the macro line type. This is expressed in drawing units.

Polyline entities are output in blocks of 200 x, y coordinates and the last x, y of the current block is the same as the first x, y of the subsequent block to maintain continuity. Each block of 200 points is described as a new Polyline record.



Field	Type	Description
1	String	'POLYLINE' Entity Identifier
2	Integer	Line Type index
3	Integer	Colour Index
4	Integer	Thickness Index
5	Integer	Curve Fit type Index
6	Real	Drawn length of pattern (0.0 = not applicable, = -ve/n = stretched between n points, +ve length of repeat pattern)
7	Real	Depth of pattern in drawing units (0.0 = according to length, +ve = pattern depth if not scaled)
8	Integer	Number of points
9	Real	X Start Point of line in drawing units
10	Real	Y Start Point of line in drawing units
11	Real	Next point
12	Real	Next point
:	:	:
Last field used Terminator	String	'ENDPOLYLINE' Entity

Example

```

POLYLINE          6          3          1          0
0.00000 X
  0.00000          5          2.00000          16.00000          4.50000
15.50000 X
  7.00000          17.00000          9.50000          16.50000          12.00000
18.00000 X
  VECTORS          3          1          2          2.00000
16.00000 X
  2.98058          15.80388          ENDVECTORS
  X
  VECTORS          3          1          2          4.05922
16.09806 X
  3.86310          15.11748          ENDVECTORS
    
```



X				
VECTORS	3	1	2	4.88629
15.73178				
X				
5.74378		16.24627		ENDVECTORS
X				
VECTORS	3	1	2	6.34403
17.18951				
X				
6.85853		16.33202		ENDVECTORS
X				
VECTORS	3	1	2	7.52462
16.89507				
X				
8.50521		16.69896		ENDVECTORS
X				
VECTORS	3	1	2	9.58384
16.99313				
X				
9.38773		16.01255		ENDVECTORS
X				
VECTORS	3	1	2	10.34506
17.00704				
X				
11.20256		17.52153		ENDVECTORS
X				
ENDPOLYLINE				
X				

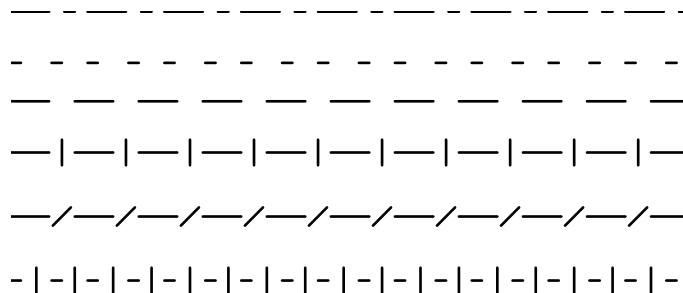


Figure 14 - 8 Examples of Lines from Line Entities

**SYMBOL entity or CENTRED entity**

The symbol entity contains line entities and/or text entities.

A symbol is defined both by its Symbol Index and the component line entities.

A total number of specific entities (lines or text) must be stated before listing the actual entities. This allows the component entities to be listed in any order within the Symbol entity.

<b>Field</b>	<b>Type</b>	<b>Description</b>
1	String	'SYMBOL' or 'CENTRED' Entity Identifier
2	Integer	Symbol Index
3	Integer	Colour Index
4	Integer	Thickness Index
5	Real	X coordinate in drawing units
6	Real	Y coordinate in drawing units
7	Real	Angle in radians
8	Real	Height of symbol in drawing units
9	Real	Width of symbol in drawing units
Last field used	String	'ENDSYMBOL' or

Example

```

ELEMENT          886          4          NSYM
SYMBOL          9          5          1          19.40000          18.90000          X
0.00000          0.00000          3.00000          X
VECTORS          5          1          11          17.90000          18.08182          X
17.90000          19.17273          18.71818          19.17273          20.08182          18.35455          X
20.08182          19.17273          20.90000          19.17273          20.90000          18.08182          X
20.08182          18.08182          18.71818          18.90000          18.71818          18.08182          X
17.90000          18.08182          ENDVECTORS          X
VECTORS          5          1          4          17.90000          19.30909          X
19.40000          20.26364          20.90000          19.30909          17.90000          19.30909          X
ENDVECTORS          X
ENDSYMBOL          X
    
```

Example

```

CENTRED          6          2          1          24.00000          12.00000          X
0.00000          0.18000          0.18000          X
VECTORS          2          1          2          24.00000          11.91000          X
24.00000          12.09000          ENDVECTORS          X
VECTORS          2          1          2          23.91000          12.00000          X
24.09000          12.00000          ENDVECTORS          X
ENDCENTRED          X
    
```

VECTOR entity

The major drawing entities describe the shape of the entity in its shortest form; but an option is provided at the start of the run to request full Vector representation of all Polylines, Symbol, Arc entities etc

Field	Type	Description
1	String	'VECTORS' Identifier
2	Integer	Colour Index
3	Integer	Thickness Index
4	Integer	Number of Points
5	Real	X, Y coordinates of points
6	Real	X, Y coordinates of points
7	Real	X, Y coordinates of points
8	Real	X, Y coordinates of points
Last field used	String	'ENDVECTORS' entity

Example

```

X          VECTORS          5          1          5          1.00000          1.00000
X          1.00000          24.00000          37.00000          24.00000          37.00000          1.00000
X          1.00000          1.00000          ENDVECTORS
    
```

HATCH entity

The hatch entity contains line entities that form the boundary and hatch. The boundary must be closed.

Field	Type	Description
1	String	'HATCH' Entity Identifier
2	Real	Hatching angle

3 Real Hatching spacing  
4 Integer Boundary indicator = 1 draw boundary  
= -1 don't draw

boundary

Drawing Entity ie POLYLINE or SYMBOL ie the boundary for the hatching.

End Drawing Entity terminator

VECTORS ) for each hatching  
END VECTORS ) line

Last field used String 'ENDHATCH' Entity terminator.

◇ *Irrespective of whether vector representation was requested, the hatching line vectors are always provided.*

Example

```

HATCH      1.57080      0.25000      -1
SYMBOL     9          3          1      19.40000      18.90000      X
0.00000    0.00000    3.00000
VECTORS     3          1          11     17.90000     18.08182     X
17.90000   19.17273   18.71818   19.17273   20.08182   18.35455   X
20.08182   19.17273   20.90000   19.17273   20.90000   18.08182   X
20.08182   18.08182   18.71818   18.90000   18.71818   18.08182   X
17.90000   18.08182   ENDVECTORS
VECTORS     3          1          4     17.90000     19.30909
X
19.40000   20.26364   20.90000   19.30909   17.90000     19.30909
X
ENDVECTORS
X
ENDSYMBOL
X
VECTORS     3          1          2     20.90000     18.08182
X
20.08182           18.08182           ENDVECTORS
X
VECTORS     3          1          2     18.71818     18.08182
X
17.90000           18.08182           ENDVECTORS
X
VECTORS     3          1          2     17.90000     18.33182
X
18.71818           18.33182           ENDVECTORS
X
VECTORS     3          1          2     19.66515     18.33182
X
20.90000           18.33182           ENDVECTORS
X
VECTORS     3          1          2     20.90000     18.58182
X
20.08182           18.58182           ENDVECTORS
X
VECTORS     3          1          2     19.70303     18.58182
X
19.24849           18.58182           ENDVECTORS
X
VECTORS     3          1          2     18.71818     18.58182
X
17.90000           18.58182           ENDVECTORS
X
VECTORS     3          1          2     17.90000     18.83182
X
18.71818           18.83182           ENDVECTORS
X
VECTORS     3          1          2     18.83182     18.83182

```

```

X
19.28637                                18.83182                                ENDVECTORS
X
VECTORS                                3                                1                                2                                20.08182                                18.83182
X
20.90000                                18.83182                                ENDVECTORS
X
VECTORS                                3                                1                                2                                20.90000                                19.08182
X
20.08182                                19.08182                                ENDVECTORS
X
VECTORS                                3                                1                                2                                18.86970                                19.08182
X
17.90000                                19.08182                                ENDVECTORS
X
VECTORS                                3                                1                                2                                20.90000                                19.30909
X
17.90000                                19.30909                                ENDVECTORS
X
VECTORS                                3                                1                                2                                18.29286                                19.55909 X
20.50714                                19.55909                                ENDVECTORS
X
VECTORS                                3                                1                                2                                20.11428                                19.80909
X
18.68571                                19.80909                                ENDVECTORS
X
VECTORS                                3                                1                                2                                19.07857                                20.05909
X
19.72143                                20.05909                                ENDVECTORS
X
ENDHATCH
X

```

Example

```

HATCH                                0.78540                                0.10000                                1
X
POLYLINE                                1                                4                                1                                0                                0.00000 X
0.00000                                11                                36.00000                                2.00000                                26.00000                                2.00000
X
26.00000                                3.00000                                36.00000                                3.00000                                36.00000                                4.00000
X
26.00000                                4.00000                                26.00000                                5.00000                                36.00000                                5.00000
X
36.00000                                6.00000                                26.00000                                6.00000                                36.00000                                2.00000
X
VECTORS                                4                                1                                11                                36.00000                                2.00000
X
26.00000                                2.00000                                26.00000                                3.00000                                36.00000                                3.00000
X
36.00000                                4.00000                                26.00000                                4.00000                                26.00000                                5.00000
X
36.00000                                5.00000                                36.00000                                6.00000                                26.00000                                6.00000
X
36.00000                                2.00000                                ENDVECTORS
X
ENDPOLYLINE
X
VECTORS                                4                                1                                2                                26.12132                                6.00000
X
26.08666                                5.96534                                ENDVECTORS
X
VECTORS                                4                                1                                2                                26.18767                                5.92493
X
26.26274                                6.00000                                ENDVECTORS
X
VECTORS                                4                                1                                2                                26.40416                                6.00000
X
26.28869                                5.88452                                ENDVECTORS
X
VECTORS                                4                                1                                2                                26.38970                                5.84412
X
26.54558                                6.00000                                ENDVECTORS
X
VECTORS                                4                                1                                2                                26.68701                                6.00000
X
26.49072                                5.80371                                ENDVECTORS
X
VECTORS                                4                                1                                2                                26.59173                                5.76331
X

```

```

26.82843          6.00000          ENDVECTORS
X
VECTORS          4          1          2          26.96985          6.00000
X
26.69275          5.72290          ENDVECTORS
X
VECTORS          4          1          2          26.00000          4.88873
X
26.11127          5.00000          ENDVECTORS
X
VECTORS          4          1          2          26.79376          5.68249
X
27.11127          6.00000          ENDVECTORS
X
VECTORS          4          1          2          27.25269          6.00000
X
26.89478          5.64209          ENDVECTORS
X
VECTORS          4          1          2          26.25269          5.00000
X
26.00000          4.74731          ENDVECTORS
X
VECTORS          4          1          2          26.00000          4.60589
X
ENDHATCH
X

```

### ARC entity

The arc entity contains arc information. An arc is defined as possessing an arc centre, a start point and an arc angle. The angle between these points is the arc angle and this must lie between 0 to 2p radians.

The arc start and centre points are defined by x, y coordinates, relative to the drawing origin in drawing units. The arc angle is measured in radians notation anticlockwise positive.

Field	Type	Description
1	String	'ARC' Entity Identifier
2	Integer	Line Type Index
3	String	Colour Index
4	Integer	Thickness Index
5	Real	X Arc centre in drawing units
6	Real	Y Arc centre in drawing units
7	Real	Radius in drawing units
8	Real	Start bearing in radians
9	Real	End bearing in radians
:	:	:
Last field used		String 'ENDARC' Entity
Terminator		

Example

```

X          ARC          1          5          1
X      2.00000          0.00000          6.28318
X      VECTORS          5          1          37          19.40000          20.90000
X      19.74730          20.86962          20.08404          20.77938          20.40000          20.63205
X      20.68558          20.43209          20.93209          20.18558          21.13205          19.90000
X      21.27938          19.58404          21.36962          19.24730          21.40000          18.90000
X      21.36962          18.55270          21.27938          18.21596          21.13205          17.90000
X      20.93209          17.61443          20.68558          17.36791          20.40000          17.16795
X      20.08404          17.02061          19.74730          16.93038          19.40000          16.90000
X      19.05270          16.93038          18.71596          17.02061          18.40000          17.16795
X      18.11443          17.36791          17.86791          17.61443          17.66795          17.90000
X      17.52061          18.21596          17.43038          18.55270          17.40000          18.90000
X      17.43038          19.24730          17.52061          19.58404          17.66795          19.90000
X      17.86791          20.18558          18.11443          20.43209          18.40000          20.63205
X      18.71596          20.77938          19.05270          20.86962          19.40000          20.90000
X      ENDVECTORS
X      ENDARC
X

```

PIPMARK entity

The pipmark entity defines the short lines drawn perpendicular to the string at each string point.

Field	Type	Description
1	String	'PIPMARK' Entity Identifier
2	Integer	Colour Index
3	Integer	Thickness Index
4	Integer	Number of points
5	Real	X coordinate of point 1
6	Real	Y coordinate of point 1
7	Real	X coordinate of point 2
8	Real	Y coordinate of point 2
Last field used		String 'ENDPIPMARK' Entity

Example

```

X      PIPMARK          2          1          2          13.99019          12.04903
X      14.00981          11.95097
X      VECTORS          2          1          2          13.99019          12.04903
X      14.00981          11.95097          ENDVECTORS
X      ENDPIPMARK
X

```

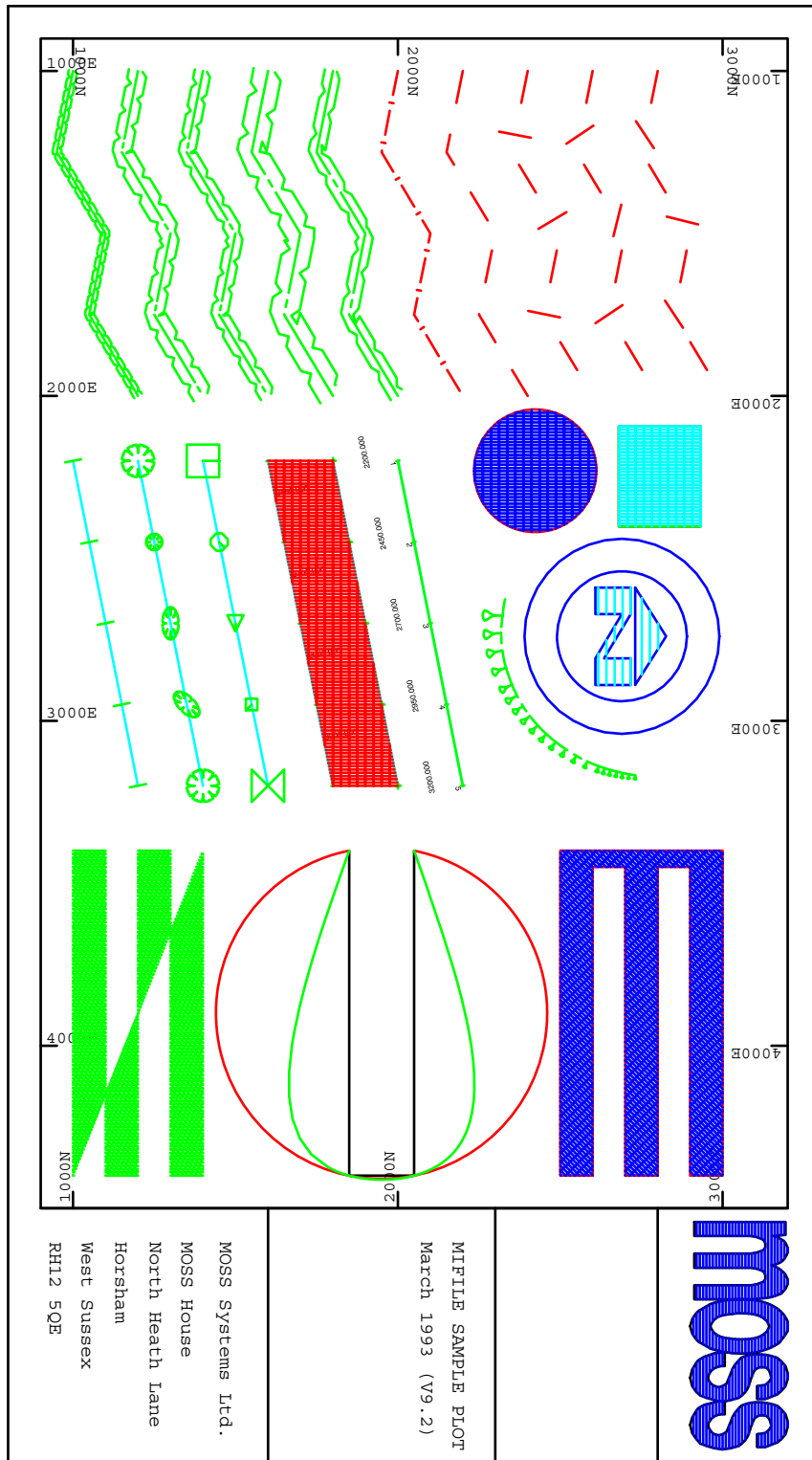


Figure 14 - 9 Example Drawing - PLOT



## Appendix A

### Errors and warnings

Messages produced by the system are of three types, prompt, error and warning. Each error and warning message has a unique number in the range 1 – 999 and is prefixed by the letter E or W to indicate its type.

Prompt messages are used in Interactive Graphic Mode IGMODE. The prompts guide you as to the next action, warn of unacceptable values or menu selection, and re-prompt until an acceptable alternative is chosen. Prompt messages remove the need for error messages in IGMODE.

Error messages indicate serious errors and may cause the option to terminate but warning messages are for information only and often contain comments.

The following pages contain a comprehensive list of messages and where necessary additional notes to suggest solutions to the problem.

- ◇ *Lowercase words in the message describe additional information to help you identify the instance generating the message.*

## MOSS error messages

### General

E001	INVALID OPTION
E002	INVALID CHARACTER (S) Non-numeric characters have been input into a numeric field.
E003	DATA FIELD OMITTED A mandatory field has been omitted from the option.
E004	INSUFFICIENT DATA
E005	INTEGER NO.OUT OF RANGE Integer number exceeds the capacity of the machine word.
E006	REAL NO. OUT OF RANGE The flagged value is not within the expected range, commonly due to: <ol style="list-style-type: none"><li>1. Angular input does not match the current setting. Use minor option 017 to reset.</li><li>2. The special or prominent contour interval is not a multiple of the normal contour interval.</li></ol>
E007	CHARACTER FIELD TOO LONG
E008	SURPLUS DATA
E009	END OF DATA REACHED FINISH option omitted.
E010	MORE THAN 49 TOO MANY MASKS SPECIFIED Up to 49 masks may be specified.
E011	TOO MANY POINTS ON BOUNDARY MAX ALLOWED = 100003000 For the majority of instances when this occurs the plan area for which the boundary is required should be defined as a series of smaller boundaries with appropriate coincident sides. This error may also occur giving a smaller figure than 100003000 but this is when the boundary intersects the edge of the sheet, and so minor option

804 has to be used to define the min/max area of the model to be drawn.

- E012      POINT INSIDE DISCONTINUITY  
The specified point lies inside a discontinuity and the string is assumed not to exist.
- E013      POINT IS AT A DISCONTINUITY  
Specified point coincides with the start or end of a discontinuity.
- E014      POINT NUMBER GIVEN DOES NOT EXIST
- E015      INVALID ORDER OF MINOR OPTIONS  
An option is coded which is dependant on another option(s) being coded previously.
- E016      ERROR IN FORMAT STATEMENT
- E017      INVALID COMBINATION OF ITEMS FOR  
STANDARD SEARCH DATA
- E018      NEGATIVE VALUES ARE NOT ALLOWED  
Negative coordinates have been coded or calculated during an option. A mixture of negative and positive coordinates are not allowed in MOSS. However, models with all negative coordinates can be used. See Chapter 2 Throughout MOSS.
- E019      SPECIFIED DATA FIELD OUT OF RANGE
- E020      DUPLICATE POINTS IN STRING
- E021      NO POINT ON REFERENCE STRING  
FROM POINT co-ordinates
- E022      GEOMETRY OF STRINGS PREVENTS  
COMPLETION OF OPTIONS
- E023      PLOTFILE TOO SMALL TO ACCEPT RESTORED FILE
- E024      MASK ALREADY SATISFIED BY  
EXISTING ENTRY  
The mask specified contradicts the previous 019 mask table.
- E025      MODELFILE TOO SMALL TO ACCEPT  
RESTORED FILE

- E026           MACROFILE TOO SMALL TO ACCEPT  
RESTORED FILE
- E027           MORE THAN 20 TOO MANY ALIASES SPECIFIED  
Only 20 alias names may be used.
- E028           VALUE IN FIELD MUST BE POSITIVE  
The data field may not contain a negative value.
- E029           INVALID COMBINATION OF DATA FIELDS
- E030           NO BOUNDARY WITHIN SEARCH AREA
- E031           NO INTERSECTION WITHIN SEARCH AREA
- E032           BOUNDARY OPEN AT : co-ordinates
- E033           TOO MANY POINTS WITHIN SEARCH AREA  
A maximum of 350 points may be handled.
- E034           SECTION STRING label NOT FOUND
- E035           INSUFFICIENT DATA – DEFAULT  
VALUE NOT OBTAINABLE  
The indicated field must be coded because a default value was not  
supplied when MOSS was installed.
- E036           MODELFIL MORE THAN number% FULL  
COMPRESS FILE BEFORE FURTHER USE  
Consult your MOSS support staff if you are not sure of the  
implications. Your model file needs to be compressed or copied to a  
larger model file before you continue any further. Before you  
compress your model file, check that you have enough space on  
your machine to carry out the procedure. You will need at least two  
times the size of the model file (model.fil) in spare capacity to carry  
out the operation. To compress a model file, go to Linemode and  
type *compress,modelfile* or use the Compress option in IGMODE.
- E037           OPTION NOT VALID ON MASTER STRING  
Editing M strings would set the chainage, bearing and radius to  
zero. This can cause problems with curve fitting.
- +E038          CONTOUR HEIGHTS DIFFER  
Attempting to join two contours with different levels.
- E039           ALIAS MUST BE SINGLE ALPHANUMERIC

Only a single letter or digit is allowed as an alias.

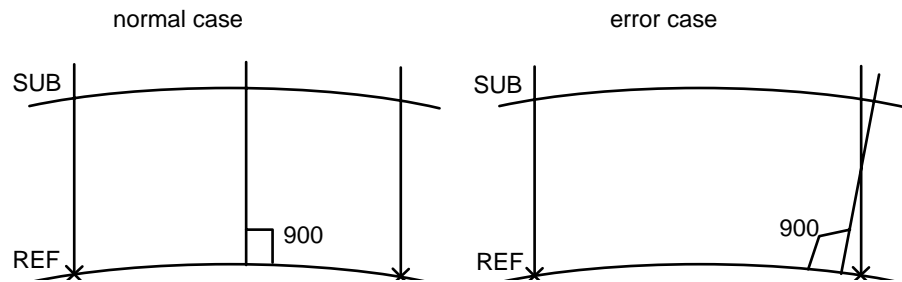
- E040            **INVALID OPTION WITHIN IGMODE**  
This is reported when an attempt is made to use DISPLAY when IGMODE is still current.
- E041            **INPUT FILE CANNOT BE OPENED**  
The input file does not exist (check spelling) or is being accessed by another user.
- E042            **INVALID INDICATOR**  
The indicator flagged is invalid – this most commonly occurs with SURVEY major option although it may happen elsewhere. Check the indicator specified against the list of allowable indicators in the manual.
- E043            **DDUPLICATE LABEL label FOUND**  
In sorting, two strings have been found with the same label. You can resolve this problem by relabelling either string.
- E045            **CANNOT RELABEL ZZZZ**  
The first character of a string label is not amended in the incrementation procedure. ZZZ is the maximum limit for the remaining characters of the label and therefore no further incrementation is possible.
- E046            **GEOMETRY STRING label INCONSISTENT  
WITH MASTER STRING label**
- E047            **STRING label DOES NOT EXIST**  
Check that you have coded the correct string label and model name.
- E048            **GEOMETRY STRING label CORRUPT**
- E049            **STRING label HAS NO POINTS**
- E050            **MODEL EXCEEDS 5000 STRINGS**
- E051            **STRING label HAS NO HORIZONTAL TP'S**
- E052            **STRING label HAS NO VERTICAL TP'S**
- E053            **STRING label HAS NO FLAT POINTS**
- E054            **GEOMETRY STRING label ONLY CONTAINS  
HORIZONTAL DATA**

- E055            CHAINAGE EXCEEDS FINAL ELEMENT
- E056            INVALID TRANSFORMATION TYPE  
You have selected an incorrect transformation type, or you may have spelt it incorrectly. There are five possible transformation types you can enter: SCAL (scaling), ROTA (rotation), HELM (helmert), TILT (tilt) or MIRR (mirror).
- E057            TOO MANY 059 OPTIONS. MAXIMUM = 100  
The input file you have supplied contains more than one hundred 059 minor options. Reduce the number by breaking the input file into smaller files, each of less than one hundred 059 minor options.
- E058            TILT CONTROL POINTS ARE COL-LINEAR  
The TILT control points you have selected form a straight line. This prevents the equation of the tilted plane from being calculated.
- E059            EXACTLY 3 TILT OPTIONS ALLOWED  
Your input file contains more than three 059,TILT options. You require three 059,TILT options to calculate the equation of the tilted plane.
- E060            INSUFFICIENT SPACE ON MODEL FILE  
The model file is not large enough to carry out the operation. To enlarge your model file (model.fil), proceed as follows:
- Use major option DUMP to take a copy of the model file
  - Use the file creation program MSFILE to create a larger model file
  - Use major option RESTORE to copy the information back onto the larger model file.
- E061            FORMAT EXCEEDS 64 CHARACTERS
- E062            CANNOT COPY GEOMETRY STRING - INTERSECTION WITH BOUNDARY
- E063            NO STRINGS IN MODEL
- E064            ERROR READING DATA
- E065            ONLY ONE MODEL ALLOWED WITH COMBINATION OPTIONS  
Cannot use a reference model when using combination options, eg 103 and 106 to design hardshoulders.
- E066            GEOMETRY/CURVATURE OF STRINGS PROHIBITS SOLUTION
-

- E067            EPIC DATA STORE NAME MUST NOT START WITH 'FINI'
- E068            CIMET2 IS ZERO  
Either one or both of the parameter file variables METR\_IMP and MET2IMP2 are set to zero. This is not allowed. For further details, consult your System Administrator.
- E069            ERROR ON COORDINATES READ
- E070            TRIANGULATION MODEL AND MODEL TO BE VIEWED ARE NOT COMPATIBLE.
- E071            NO TRIANGULATION MODEL HAS BEEN SELECTED
- E072            PROMINENT INTERVAL MUST BE MULTIPLE OF NORMAL INTERVAL  
INTERVAL IS NOT A MULTIPLE OF THE NORMAL INTERVAL
- E073            TRACEBACK EXCEEDS 1000 TRIANGLES  
The string currently being introduced into the triangulation causes more than 1000 triangles to be returned. Use 017, ECHO to trace this string.
- E074            MODEL NAMED TO STORE TRIANGLES IS NOT A TRIANGULATION MODEL
- E075            ARCHIVE FACILITY MAY ONLY BE USED ONCE IN ANY JOB
- E075            ARCHIVE FACILITY MAY ONLY BE USED ONCE IN ANY JOB UNLESS FILENAME IS REASSIGNED.
- E076            MODEL name  
NOT ON ARCHIVE FILE
- E077            MODEL HAS NON-ALPHANUMERIC CHARACTER  
Only A to Z and 0 to 9 are allowable characters in model names.
- E078            STRING HAS ONLY 1 POINT  
Geometric properties cannot be calculated from a single point only, or in VIEW you will not be able to see a string with only one point.
- E079            CHAINAGE SPECIFIED FOR NON-MASTER ALIGNMENT

The reference string is not a master alignment (M string) and so cannot interpret SPRD containing chainages.

- E080            MODEL NAME NOT SPECIFIED
- E081            INVALID FILE NAME  
File names may be MACROFILE, MODELFILE, ARCHIVEFILE.
- E082            MODEL DOES NOT EXIST OR MODEL TYPE INVALID FOR  
OPTION
- E083            MODEL ALREADY EXISTS  
You cannot rename or retrieve a model with this name as a model  
by this name already exists in the model file.
- E084            SECURITY, NO ACCESS TO THIS MODEL  
You cannot write to a model that has been secured as a read-only  
model. Use major option FREE to remove the security from the  
model.
- E085            ASSOCIATED POINT IS OUTSIDE RANGE  
The associated point from a non-exact point on the reference string  
does not lie within the normal erected at the exact points on either  
side of the reference point.



**Figure A - 1    Example of E085**

The solution is either to regenerate the reference string at a similar interval or to be more precise in defining the reference points. Normally the problem arises when the reference point is extremely close to but not coincident with an exact point.

- E086            POINT co-ordinates  
CANNOT BE FOUND ON STRING label
- E087            STRING INTERSECTION DOES NOT EXIST



E088	<b>DISCONTINUITY FOUND</b> The string you are using as a reference string or subsidiary string has a discontinuity in it. You can either delete the discontinuity using EDIT 005 or carry out the design over the range of the string before the discontinuity and after the discontinuity.
E089	<b>POINT CANNOT BE FOUND</b>
E090	<b>INVALID MINOR OPTION NUMBER</b>
E091	<b>STRING DOES NOT EXIST</b>
E092	<b>STRING ALREADY EXISTS</b> A string of this label has already been created and already exists in the model.
E093	<b>STRING HAS NO POINTS</b> A string without any points in it has been stored on the model and therefore nothing can be calculated. Delete the string before recreating it.
E094	<b>INCOMPATIBLE SUB-REFERENCE</b>
E095	<b>DIMENSION OF STRING OMITTED</b> To input a string you must say how many dimensions it has.
E096	<b>DIMENSION OF STRING IS INVALID</b> The dimension you have specified is invalid for the string you have selected. For example, you may have specified the sixth dimension but the string only has three. To check the number of dimensions in a string, use REPORT 992.
E097	<b>INVALID STRING LABEL SPECIFICATION</b>
E098	<b>LABEL OF STRING OMITTED</b> The string label can only contain the characters A - Z and 0 - 9 (or initial character * for a text string).

### **System Errors**

In addition to the standard warning and error messages which are aimed at helping the user, there is a set of system error messages. These are all numbered Error E99 and certain additional information is printed. There are two types of system error:-

- Program Errors - require help from MOSS Systems Ltd.

- File Errors - normally caused by a full or corrupt file. Require help from a programmer at the user installation, for example to restore a file. The programmer may in turn need to contact MOSS Systems Ltd. File system error messages are accompanied by an extra line of information indicating the file involved.

The MOSS system will always stop after a system error. On some computer systems it is possible to print a subroutine traceback after the error, to help trace the source of the system error.

The standard message format is as follows:-

E 99

**SYSTEM ERROR NNN  
JOB TERMINATED BECAUSE OF SYSTEM ERROR  
- ABNORMAL END OF JOB**

<b>Error</b>	<b>Extra Information</b>
000	Major option DRAW. Incorrect string label.
001	Illegal colour request.
001	Illegal string.
002	Model not found for string existence checks.
003	String not found for index deciphering.
004	Major option REPORT. Sorted string not found.
006	Major option REPORT. Invalid report selection.
007	Illegal exit from MOSS.
008	Major option REPORT. Invalid report selection.
009	Invalid model file size - not set up correctly.
010	Invalid model file size - not set up correctly.
011	Invalid model file size - not set up correctly.
012	Linked list overflow while allocating string labels.
014	Invalid string point value.
015	Invalid string point value.
016	Corrupt macro file index.
01	Invalid model number - not 1, 2 or 3.
018	Invalid edit method - not in range 1 to 6.
019	Invalid string point value.

020	Major option HALGN. Invalid element definition.	
021	Major option HALGN. Invalid element definition.	
022	Chain > end of element chainage or < start of element - special chainage on trailing transition - reduce chainage interval to avoid start transition and special chainage being printed next to each other. Major option HALGN.	
023	Major option HCUSP. Model/string label in error.	
026	Major option HALGN. Invalid element definition.	
027	Major option HALGN. Invalid element definition.	
028	Ground model not found in sectioning routine.	
029	Section model not found in sectioning routine.	
030	Ground model not found in sectioning routine.	
033	Unable to form string label.	
035	Major option INTERFACE. Model not found.	
037	Major option REGAIN.	
038	Major option REGAIN.	Corrupt model file.
039	Major option REGAIN.	
040	Major option REGAIN.	
041	) Model file is full or corrupt	
042	) - this job has filled the model file, or the file was	
043	) corrupted by a previous job.	
044	) Model file is full	
045	) - this job has filled the model file.	
046	)	
049	No route out of triangle for current link.	
050	Illegal range for character check.	
051	Text profile not on message file.	
052	Error in creating text strings.	
054	Invalid model file point read/write. (Preceded by an MTRANG post mortem printout).	
057	Corrupt model file header.	
058	Corrupt model file header.	

060	Incorrect record address on macro file.
061	Invalid indicator to subroutine macrw.
063	Macro file is full.
064	Model file is full or corrupt.
065	Corrupt archive file.
066	Corrupt archive file.
067	Incorrect CUT/FILL indicator.
068	Corrupt model
069	Invalid file access mode.
070	Invalid file access mode.
071	Invalid file access mode.
074	Major option VALGN. Illegal curve type.
075	Major option VALGN. Illegal curve type.
076	Major option VALGN. Illegal curve type.
077	Illegal temporary model pointer.
078	Major option VIEW. Invalid triangulation point value.

**Draw System Errors**

079	Major option VIEW. Invalid string point.
080	Major option DRAW.
080	
081	GEPSX has not been able to find secondary index for GRID /FRAME / TITL.
082	Bad return from FIXCHA.
083	Routines errors in writing to D.A.P.F.
084	Routines errors in adding index entries. (Try using Compress DPF to identify corrupt string)
085	Illegal minor option encountered invalid work file ud 1.
086	No more room in master index arrays.
087	Single point X sections or

	Bad return code from DENTST.
088	Bad return code from KINPLY.
089	Bad return code from GETPOI.
090	Previous page not complete.
091	Error from call to FIMODL or STORBY.
092	Grid will not fit at given interval for required drawing scale.
092	Attempt to get a non existantexistent section record or one of the wrong type.
093	Device major option has not found match in the device table.
094	Illegal value of KSDWD.
095	System error not detected until stage 3.
095	Identical points on string - attempting to curve fit / SETVAR > 10 line styles set default printer 861.
096	Illegal TITLE type detected
096	Error when determining page number for a string link passing through a page.
097	Node label has disappeared since stage 1.
098	Too many string labels for array.
099	Model length < 0.
100	Number of pages exceeds 100.
101	No current object.
102	Object should not point to header, page or model index records. Whole index is empty.
103	Non alpha-numeric character in variable name.
104	Bad box number. Bad return from SEQRDE.
105	No object?
106	Unexpected node (note 846 or 849).
107	Bad return from DENTST. (Section may be too long for sheet)
108	Variable should have already been checked to exist.

	Reference string should have been available.
109	Bad return from GEPMOD. Model not found.
110	Bad return from GEPMOD. More than one model.
111	Too many objects.
112	X section scale too big. Space used by BDPOLY does not match number of sections indicated by NSCOLS array.
113	Dimension invalid for option 826S.
114	Default object not empty.
115	Invalid code in ICTYPE.
E100	ERROR OPENING FILE name
E102	INVALID PICTURE CODE ( )
E103	PICTURE TEXT RECORD TOO LONG
E104	NO EOF MARKER ON PICTURE FILE
E105	ERROR READING SOFTWARE FONT FILE, PROCESS STOPPED

**Modular MOSS errors**

E110	SOFTWARE PRODUCT NOT LICENSED MAJOR OPTION NOT AVAILABLE An attempt has been made to call a major option which is not available in this version of MODULAR MOSS.
E111	TRIAL TIMEOUT EXCEEDED – MAJOR OPTION NOT AVAILABLE SOFTWARE PRODUCT NOT LICENSED TRIAL LICENCE EXPIRED The licence period for a trial version of MODULAR MOSS has expired.
E112	PROGRAM NOT AVAILABLE SOFTWARE PRODUCT NOT LICENSED
E113	TRIAL TIMEOUT EXCEEDED – PROGRAM NOT AVAILABLE

- E113 SOFTWARE PRODUCT NOT LICENSED  
TRIAL LICENCE EXPIRED
- E114 NUMBER OF AVAILABLE LICENCES EXCEEDED  
ACCESS DENIEDMODULE CONCURRENCY EXCEEDED
- E115 NUMBER OF AVAILABLE LICENCES EXCEEDED  
ACCESS DENIED
- E115 PROGRAM CONCURRENCY EXCEEDED
- E116 MINOR OPTION NOT AVAILABLE  
The minor option you have specified does not exist or is not licensed.
- E123 INPUT RECORD EXCEEDS 80 COLUMNS

**Major option EDIT**

- E137 CANNOT CREATE M STRING FROM SPLINE G STRING
- E138 INVALID CHAINAGE INTERVAL  
You cannot have a blank, zero or negative chainage interval.
- E139 NULL LEVEL ENCOUNTERED AT POINT  
number ON SUBSIDIARY STRING label  
The option requires every point within the SPRDon the subsidiary string in the specified range to have a level.
- E140 STRING ALREADY EXISTS AND IS  
NOT A SLOPE SIGNATURE STRING  
You can only append slope signature data to slope signature strings.
- E141 START/FINISH POINTS ARE IDENTICAL
- E142 END POINTS MUST BE SEPARATED BY  
AT LEAST ONE CHAINAGE INTERVAL
- E143 IDENTICAL SUBSIDIARY STRINGS GIVEN SAME LABEL  
The subsidiary strings you have specified in EDIT 036 are the same. Two different subsidiary strings must be specified for the slope signature strings to be created.
- E144 INVALID STRING TYPE
- E145 STRING label HAS LESS THAN 3 POINTS

- E146 SUBSIDIARY STRINGS DO NOT OVERLAP
- E147 INVALID INDICATOR - REGU REQUIRED
- E148 INTERVAL MUST BE GIVEN FOR 'REGU'
- E149 CONTOUR STRING SELECTED  
SUB-REFERENCE CANNOT CHANGE
- E150 UPMs TO BE SECURED MUST BE SUPPLIED USING MINOR  
OPTION 401
- E151 INVALID FORMAT FOR USER REFERENCE
- E152 UNABLE TO READ UPM FILE
- E153 UPM FILE HAS ALREADY BEEN SCRAMBLED
- E154 UPM FILE NAME IS TOO LONG
- E155 UNABLE TO OPEN UPM FILE
- E160 STRING MUST BE DRAWN USING 856

**Major option REPORT**

- E180 CANNOT CALCULATE SLOPE LENGTH NULL LEVEL AT POINT  
coordinates
- E181 INAPPROPRIATE STRING TYPE FOR OPTIONOPTION FOR  
POINT STRING

**Major option DESIGN**

- E200 CROSSFALL CHANGE OVER EXTENDS  
OUTSIDE CLOTHOID LENGTH AVAILABLE = number
- E201 CROSSFALL CHANGE OVER LENGTH OVERLAPPED  
The crossfall changeover has been given an offset. However, it is  
so large that the end of the first changeover would follow the start of  
the second changeover. This is not allowed.
- E202 CHANGE OVER OFFSET EXCEEDS  
THE CHANGE OVER LENGTH
- E209 MAXIMUM NUMBER OF POINTS EXCEEDED
- E210 FIRST ASSOCIATED POINT NOT FOUND



To determine the start and end of a string to be created or modified, normals are erected at the start and end points on the reference string. If the string already exists, it is searched for its intersections with the normals to determine if the option is extending or amending the string. The point of intersection of the string and normal at the start of the reference string is referred to as the 'first associated point' and the normal at the end of the reference string determines the 'last associated point.' These points also exist on the subsidiary string if specified.

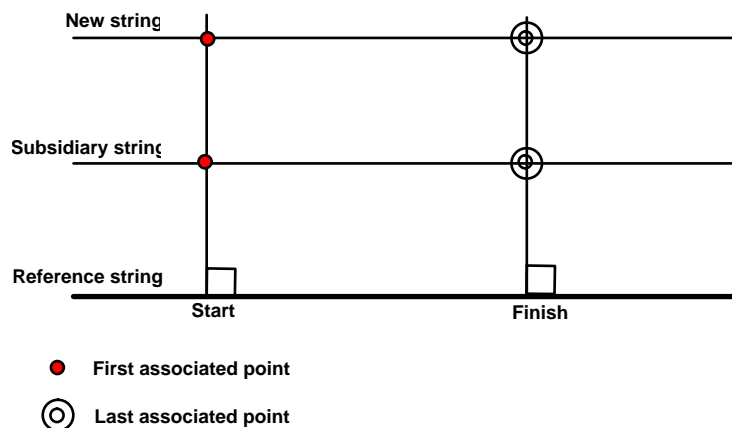


Figure A - 2 Example of E210

In the case of horizontal options, the length of the normal is restricted to the maximum offset specified in the option, plus ten per cent, on either side of the reference string. This is to avoid the situation when extending a string where an intersection is found but is not the one required.

Check your data to ensure:

- the normal from the reference string really ought to intersect the string being modified.
- the string being modifies exists over the range you have specified and has not been changed by an earlier option.
- neither the reference string nor the string being modified is a closed string.

E211

LAST ASSOCIATED POINT NOT FOUND

The normal erected from start/finish point on the reference string does not intersect the subsidiary or the string to be amended. The appropriate string on which the associated point cannot be found is flagged. Corrective action will usually be dictated by reference to the particular configuration of data together with the principles of

geometric manipulation as described in the documentation for major option DESIGN.

To determine the start and end of a string to be created or modified, normals are erected at the start and end points on the reference string. If the string already exists, it is searched for its intersections with the normals to determine if the option is extending or amending the string. The point of intersection of the string and normal at the start of the reference string is referred to as the 'first associated point' and the normal at the end of the reference string determines the 'last associated point'. These points also exist on the subsidiary string if specified.

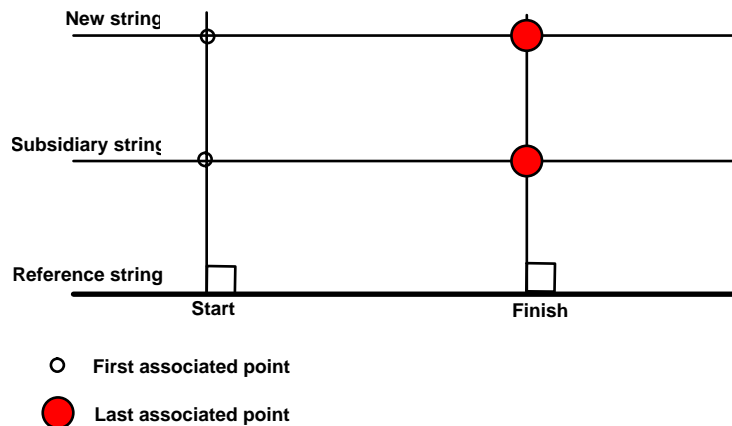


Figure A - 3 Example of E211

In the case of horizontal options, the length of the normal is restricted to the maximum offset specified in the option, plus ten per cent, on either side of the reference string. This is to avoid the situation when extending a string where an intersection is found but is not the one required.

Check your data to ensure:

- the normal from the reference string really ought to intersect the string being modified.
- the string being modified exists over the range you have specified, and has not been changed by an earlier option.
- neither the reference string nor the string being modified is a closed string.

E212

NULL LEVEL ENCOUNTERED IN STRING

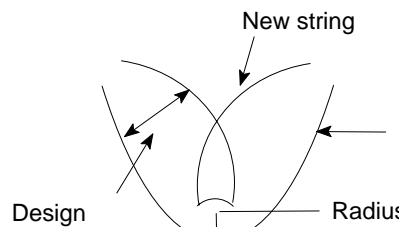
Wherever a design option manipulates the vertical dimension of a string level must have a value greater than -999.0, over the length of interest, whether it be on the reference string or the subsidiary

string. Whenever a DESIGN option manipulates the vertical dimension of a string, the level at each point in the specified range must have a value greater than -999.0, whether it be on a reference string or a subsidiary string.

**E213 RADIUS FOUND IS LESS THAN OFFSET**

The radius of the reference string over a particular design application range is smaller than the offset at which the new string is placed. An example of a situation that will cause this error is shown in the following diagram.

An example of a situation that will cause this error is shown in the following diagram.



**Figure A - 4 Example of E213**

**E214 141 OR 142 OPTION OMITTED**

An option 140 to generate a string described by a circle (141) or a straight line (142) must have either the 141 or 142 option present. DESIGN minor option 140, which generates a string described by a circle (minor option 141) or a straight line (minor option 142) must have either minor option 141 or 142 present.

**E215 140 OPTION OMITTED**

Where it is required to generate a string described by a circle (141) or a straight line (142) either the 141 or 142 option must be present. When generating a string described by a circle (DESIGN minor option 141) or a straight line (DESIGN minor option 142), minor option 140 must also be present.

**E216 CHAINAGE INTERVAL OMITTED**

Options 140 with 141 or 142 generate six dimensional strings and for this reason a chainage interval needs to be specified on option 140.

**E217 TOLERANCE ERROR: CHAINAGE INTERVAL REQUIRED < 0.01**

Option 140 with 141 generates a string of points lying on a circle. If the radius of this curve is so small that the chainage interval necessary to give accurate definition of the curve is less than 0.01 the above error occurs.

- E218            CHAINAGE INTERVAL ZERO  
Options 140 with 141 or 142 generate six dimensional strings and for this reason a chainage interval needs to be specified. This has been defined as zero which is invalid.
- E219            INVALID SIGNIFICANCE LEVEL GIVEN  
The valid levels are 50.0, 80.0, 90.0, 98.0 and 99.0.
- E220            ASSOCIATED POINT ON string A label NOT  
FOUND BETWEEN min offset range AND  
max offset range OF POINT number ON string B label  
Although the first and last associated points on string A have been found the associated point of the intermediate point number on string B does not exist within the offset range. This usually means that although the first and last associated points have been found they are in fact in error.
- E221            CIRCLE CENTRE POSITION OMITTED
- E222            NO RADIUS GIVEN
- E223            START/END VALUES SHOULD DIFFER  
The values should differ by more than the point search tolerance. Between the start and end of application, you have asked for a changing offset or crossfall, but you have defined the offset or crossfall to be constant.
- E224            START AND END POINTS TOO CLOSE  
Distance must be greater than than the point search tolerance. The distance between the start and end points must be greater than the point search tolerance.
- E225            ALL THREE POINTS COLLINEAR  
The plane is not fully defined because the three points defining it all lie on a straight line.
- E226            FIELDS 7 & 10 OF OPTION number ARE  
BLANK – OPTION number SHOULD FOLLOW

Option 122 and 132 require supplementary information on options 125 and 135 if fields 7 and 10 are blank. If options 125 and 135 are not required then fields 7 and 10 should be coded.

- E227            APPLICATION LENGTH OF ARC TOO LONG  
FOR RESULTING START AND END LEVELS  
Options 125 or 135 fits circular reverse curves but the geometric  
arrangement cannot be accommodated with the data supplied.
- E228            number OPTION OMITTED  
A 134 must be followed by a 104 minor option.
- E229            number OR number OPTION OMITTED  
A 103 minor option must be followed by a 104 or a 105 minor  
option.
- E230            REVERSE ANALYSIS NOT PERMITTED.
- E231            number OR number OR number OPTION OMITTED
- E232            CHAINAGE INTERVAL TOO LARGE
- E233            ERROR WHILE ADDING PACKAGE TO FILE
- E234            INVAOLID ENTRY. RETRY.
- E235            NO FILE NAME ENTERED. RETRY.
- E236            FILE CANNOT BE FOUND. RETRY.
- E237            PACKAGE NAME EXCEEDS 12 CHARACTERS. RETRY.
- E238            CUSTOMER ID HAS A MAXIMUM OF 5 DIGITS. RETRY.
- E239            CONCURRENCIES HAVE A MAXIMUM OF 3 DIGITS. RETRY.
- E240            INVALID FORMAT FOR DATE. RETRY.
- E241            INVALID DATE. RETRY.
- E242            DATE GIVEN IS IN THE PAST. RETRY.
- E243            INTEGER VALUE OUT OF RANGE. RETRY.

#### **GENIO file assignment errors**

- E250            DATA OMITTED

You need to assign the output channel as being either GENIO or MACRO.

- E251            OUTPUT CHANNEL IDENTIFIED IS IN ERROR  
You need to assign the output channel as being either GENIO or MACRO.
- E252            OUTPUT FILENAME ALREADY EXISTS  
ASSIGN will only open the specified file if it does not already exist. Major option OVERWRITE will allow you to open an existing file.
- E253            UNABLE TO OPEN INPUT AND OUTPUT CHANNELS FOR SAME FILE NAME
- E254            INPUT FILE DOES NOT EXIST
- E255            OUTPUT FILE DOES NOT EXIST
- E256            INPUT CHANNEL ALREADY OPEN TO ANOTHER FILE NAME
- E257            OUTPUT CHANNEL ALREADY OPEN TO ANOTHER FILE NAME
- E258            FILE ALREADY OPENED IN ANOTHER CHANNEL

#### **Major option HALGN**

- E295            ELEMENT HAS TOO MUCH FIXITY
- E296            TRANSITION CURVE LENGTH CANNOT BE CALCULATED
- E297            TRANSITION TOOL LONG BETWEEN ELEMENTS label AND label
- E298            ADJACENT ARCS WITH IDENTICAL RADII  
You cannot calculate a transition between two arcs of equal radius.
- E299            INVALID TRANSITION DATA
- E300            TRANSITION TYPE NOT AVAILABLE BETWEEN ELEMENTS label AND label
- E301            number FIELD MISSING  
The identified field needs to be present.
- E302            number OR number FIELDS MISSING  
One of either identified fields needs to be present.
- E303            OPTION 304 MUST CONTAIN 3 NUMBERS

- For a special chainage interval the start chainage (SC), finish chainage (FC) and chainage interval (CI) all need to be defined.
- E304 CE CANNOT BE NEGATIVE  
Chainage interval on elements must be positive.
- E305 MORE THAN 500 ELEMENTS
- E306 ELEMENT TYPE NOT DEFINED  
The element must be specified as SX, SL, SE, RX, RL, RE, LX, LL or LE depending on it being a straight, or left hand right curve and on its fixity.
- E307 THE FIELD TO BE TRANSFERRED TO THE 301 OPTION IS MISSING  
Having defined an offset alignment the information to be passed to the element definition needs to be given.
- E308 ONLY ONE OF P1, P2, P3 MAY BE TRANSFERRED TO THE 301 OPTION  
Only one point at a time may be calculated from an offset alignment and transferred to the element record.
- E309 label FIELD ALREADY ON 301 OPTION  
An attempt has been made to transfer from an offset alignment information which has already been given on the element record.
- E310 SPECIAL CHAINAGE OUT OF SEQUENCE  
Special chainages must be given strictly increasing order.
- E311 MORE THAN 500 SPECIAL CHAINAGES
- E312 START CHAINAGE LESS THAN PREVIOUS FINISH CHAINAGE  
For special chainage intervals the extents must lie within the start and finish of the overall alignment.
- E313 START CHAINAGE LESS THAN ALIGNMENT START CHAINAGE  
For special chainage intervals the extents must lie within the start and finish of the overall alignment.
- E314 FINISH CHAINAGE LESS THAN START CHAINAGE

- For a special chainage interval the finish must lie after the start chainage.
- E315 MORE THAN 500 304 OPTIONS.
- E316 CT CANNOT BE NEGATIVE  
Chainage interval on transitions must be positive.
- E317 INPUT DATA INCONSISTENT FOR  
ELEMENT label  
The amount of data given to define the element does not support the element type defined.
- E318 POINTS P1 AND P2 COINCIDE FOR  
ELEMENT label
- E319 RADIUS WILL NOT FIT BETWEEN P1  
AND P2 FOR ELEMENT label  
The distance between points P1 and P2 exceeds twice the radius (ie the diameter) and thus the circle cannot be fitted.
- E320 DEFINED POINT ON ELEMENT label  
TOO CLOSE TO ELEMENT label  
The point specified for a floating element is too near to or inside the associated element to which the floating element is to be attached to accommodate the relevant transitions.
- E321 CANNOT CALCULATE RADIUS FOR  
ELEMENT label DEFINED POINT ON  
ELM. label TOO CLOSE TO ELM. label  
ASSOCIATED TRANSITIONS REMOVED.
- E322 ELEMENTS label AND label INTERSECT  
CLEARANCE = number
- E323 ELEMENT label AND label INTERSECT  
INSERT FREE CURVE type  
WITH RADIUS number
- E324 ELEMENTS label AND label  
ARE ADJACENT STRAIGHTS
- E325 ELEMENTS label AND label  
HAVE CENTRES TOO CLOSE TOGETHER



- E326 STRAIGHTS label AND label  
ARE PARALLEL
- E327 ELEMENT label CANNOT BE FITTED  
This message will normally be preceded by one of the earlier  
messages.
- E328 SOME ELEMENTS CANNOT BE FITTED  
This message will always be preceded by at least one of the earlier  
messages giving an explanation of difficulties encountered.
- E329 CALCULATED START/END OF STRAIGHT  
INCONSISTENT FOR ELEMENT label  
The calculated start point of the straight is ahead of the calculated  
finish point of the straight.
- E330 POINTS P1, P2, P3 IN STRAIGHT LINE
- E331 POINTS P1, P2 IN LINE OF BEARING
- E332 ALIGNMENT BROKEN BETWEEN  
ELEMENTS label AND label
- E333 INVALID ANGULAR DEFINITION : number  
The angle defined does not lie in the range 0 – 360<sup>0</sup>. Appears when  
the angular type is degrees, minutes and seconds.
- E334 INVALID ANGULAR DEFINITION : number  
The angle defined does not lie in the range  
0 – 360 when the angular type is decimal degrees DEGR  
0 – 400 when the angular type is gradians GRAD  
0 – 6.28328 when the angular type is radians RADI

### **Major option HCUSP**

- E335 NO INITIAL DATA RECORD  
Initial data record for major option HCUSP has been omitted.
- E336 SURPLUS DATA – XXX LCTN PT RECORDS  
PLUS YYY SPEC CH. RECORDS EXPECTED  
The number of location point records does not match the data in  
field 9 on the initial data record.
- E337 CHAINAGE INTERVAL ZERO
- E338 NO. OF LCTN PTS NOT IN RANGE 2–500

A minimum of 2 and a maximum of 500 location points may be specified.

- E339            **ADDED LOCATION PTS EXCEED MAXIMUM**  
A maximum of 500 location points is allowed. The added location points has exceeded this maximum.
- E340            **START/FINISH BEARING MISSING**
- E341            **INVALID COMBINATION OF DATA**  
At least one location point is required between fixed elements/points to permit the introduction of a cubic spline.
- E342            **MORE THAN 300 SPECIAL CHAINAGES**
- E343            **SPECIAL CHAINAGE OUT OF SEQUENCE**  
Special chainages must be requested in increasing chainages.
- E344            **DUPLICATE LOCATION POINT**  
Two successive location points are coincident.
- E345            **CIRCLE DIAMETER TOO SMALL TO FIT**  
Impossible to fit the specified circular arc between the location points, as the distance between them exceeds the diameter.
- E346            **SLOW CONVERGENCE – CHECK FOR DATA ERROR – TRY MORE LCTN POINTS**  
The line is not sufficiently well defined and the option is experiencing difficulty calculating the curve distance between adjacent points. Too great an angle of curvature is being consumed between a pair of location points and an additional location point is required to sub-divide this length. Frequently the problem is caused by an error in the coordinates of a location point.
- E347            **START CH. GT CH. OF LAST POINT**  
The chainage at which printout was requested to begin lies after the chainage of the last location point on the alignment.
- E348            **RADIUS (PT. number) TOO SMALL FOR ADJACENT ELEMENT**
- E349            **INSUFFICIENT DATA – XXX LOCATION POINT PLUS YYY SPEC CH. RECORDS EXPECTED**  
The 999 record has been reached before all the data, as specified on the initial data record, has been read. The last record (999) has

been reached before all the data, as specified on the initial data record, has been read. Check the data on the initial data record and ensure that all the following location point and special chainage records have been specified.

### Major option DRAW

- E350**            **SCALE NOT SET BY AN 803 OPTION**  
To produce any plan drawing a horizontal scale must be defined and for a section drawing both a horizontal and vertical scale must be defined. Scales may only be set by minor option 803. If macros are being used the variables SC = (PLANDRAW) or HS = and VS = (LONGDRAW/CROSDRAW) must be set.
- E351**            **884 MUST BE PRECEDED BY 883**  
Before a line of text to be drawn is specified its position must be defined.
- E352**            **885 MUST BE PRECEDED BY 883**  
Before a line of text to be drawn is specified its position must be defined.
- E354**            **TOTAL MARGINS EXCEED SHEET SIZE**  
The left and right margin together must be smaller than the sheet length so as to leave a drawing area. Similarly the top and bottom margins must be smaller than the sheet width.
- E355**            **OLD OPTION 800 DISALLOWS OPERATOR INFORMATION ON 820**
- E356**            **OPTION MAY NOT BE REPEATED WITH PAGED PLOT**
- E357**            **NEW 803 REQUIRES PRECEDING NEW 802**  
New margins must be defined (Option 802) before a new scale can be requested (Option 803). Usually refers to composite drawings.
- E358**            **CANNOT PLOT MULTIPLE STRINGS WITH STANDARD POINT REFERENCE DATA**  
If standard point reference data is defined then only a partial string is being drawn, and each string must be specifically requested.
- E359**            **COMPLETE STRING LABEL REQUIRED**  
Partial labels in certain options are not permitted
- E360**            **876 OPTION MUST FOLLOW 875 OPTION**

Hatching is defined between two strings the first being defined by an 875 and the second by an 876.

- E361            **INVALID CHARACTERS IN ITEM LABEL**  
Only the characters 0 – 9, A – Z may be used to define a label.
- E362            **MACRO SPECIFIED IS OF WRONG TYPE**  
Either a macro symbol has been defined as a macro line or a macro line has been defined as macro symbol.
- E363            **878 OPTION MUST FOLLOW 877 OPTION**  
Hatching is defined between two lines the first being defined by an 877 and the second by an 878.
- E364            **MACRO SPECIFIED NOT IN LIBRARY**  
The macro which has been requested does not occur in the library. The macro defined may have been miss-spelt.
- E365            **INVALID SHEET SPECIFICATION**  
Only A size sheets 0 – 10 and B size sheets 0 – 5 or actual sheet length and width may define a sheet.
- E366            **INVALID MACRO SPECIFICATION – COL.3**
- E367            **MORE THAN 2 REF. POINTS IN MACRO**
- E368            **ONLY ONE REFERENCE POINT IN MACRO**
- E369            **MUST TRUNCATE AN INFINITE SHEET**  
NOTR has been defined on option 803 but an infinite sheet has been defined on option 800.
- E370            **PAGING INVALID FOR INFINITE SHEET**  
PAGE has been defined on option 803 but an infinite sheet has been defined on option 800.
- E371            **TOO MANY POINTS IN HATCHING POLY**
- E372            **837 OPTION MUST FOLLOW 836 OPTION**
- E373            **INVALID DIM. OF NODE/ZONE STRING**
- E374            **START NODE GREATER THAN END NODE**
- E379            **EMPTY PICTURE FILE**

No current picture (.dpf) file exists to enable requested graphical option.

E380

INVALID DESCRIPTOR

E381

REQUIRES PRECEDING 803 PLAN

This option cannot proceed without the definition of scale using option 803. The drawing scale must be specified using minor option 803 before this option can be carried out.

E382

REQUIRES PRECEDING 803 LONG

The drawing scale must be specified using minor option 803 before this option can be carried out.

The option cannot proceed without scales having been defined on an 803 option.

E383

REQUIRES PRECEDING 803 CROSS

The drawing scale must be specified using minor option 803 before this option can be carried out.

The option cannot continue without the definition of a scale defined on an 803 option.

E384

TOO LITTLE SPACE LEFT FOR PLOTTING

E385

START/END POINT OF REF. STRING  
OUTSIDE RANGE OF LAST 804 OPTION

The domain defined is in conflict with the start or end point of the reference string required.

E386

MAXIMUM NUMBER OF SHEETS EXCEEDED

A .dpf file may contain a maximum of 100 sheets.

E387

BOX CANNOT BE REDEFINED

The box identification has already been used.

E388

MAXIMUM NUMBER OF BOXES EXCEEDED

E389

BOX NOT PREVIOUSLY DEFINED

Before annotation of a box can be defined the box's location must be specified.

E390

INTERVAL GREATER THAN SPRD

The interval for drawing annotation or ordinates is wider than the range over which you want them drawn.

- E391            CANNOT PLOT REFERENCE STRING DATA  
                 AT RIGHT ANGLES TO ITSELF
- E392            VARIABLE NOT DEFINED  
                 Before assigning values to a variable the box into which the variable  
                 will go must be specified.
- E393            VARIABLE ALREADY DEFINED  
                 The variable name has already been used.
- E394            MAXIMUM NO. OF VARIABLES EXCEEDED  
                 The maximum number of variables allowed is 10.
- E395            UNABLE TO ACCESS STRING label  
                 TO GENERATE VARIABLE label  
                 Search for invalid sections labels or incompatible station intervals  
                 related to the identified label.
- E396            TOO MANY OBJECTS ON SHEET –  
                 MAXIMUM POSSIBLE IS number  
                 Make sure the section intervals in the DRAW options are compatible  
                 with the section intervals in the models.
- E397            CANNOT SPECIFY CHAINAGE INTERVAL  
                 FOR NON-MASTER X-SECTION REF.  
                 The string from which the cross sections were generated is not a  
                 master alignment string and consequently chainages and chainage  
                 interval may not be defined.
- E398            START/END POINTS NOT ON BASE LINE  
                 The base line defined for the cross section reference does not  
                 coincide with the base line from which the original cross sections  
                 were defined.
- E400            name MACRO NOT IN LIBRARY
- E401            SURPLUS DATA  
                 More information has been defined than is required. The field  
                 flagged is the suggested field which is in error.
- E402            START POINT NOT AT EXACT POINT  
                 Cross section may only be generated at exact points on the  
                 reference string.
- E403            FINISH POINT NOT AN EXACT POINT

Cross sections may only be generated at exact points. on a reference string.

- E404      **MORE THAN 10 OPTION 804 RECORDSAX NUMBER OF 804 OPTIONS EXCEEDED**  
A maximum of 10 804 minor options are allowed per drawing.
- E405      **LENGTH DEFINED BY A PREVIOUS 804**  
This error reports an attempt to redefine the length of a longitudinal section when this has already been defined on an earlier 804 minor option.
- E406      **OFFSETS LEAVE NO ROOM FOR SECTION**  
The offsets on a cross section are too large to allow the cross section to be drawn within the space available.
- E407      **SHEET LENGTH EQUAL TO ZERO**  
This can be caused by insufficient room on a sheet to draw a section, so either increase sheet size, reduce scale or reduce margins. If the error occurs in Plan drawing, simply type MOSS to reset the error.
- E408      **SHEET WIDTH EQUAL TO ZERO**  
These errors result from an attempt to draw sections which do not exist in the model file.
- E409      **VARIABLE NAME EXCEEDS 4 CHARACTERS**  
On an 847 minor option the text variable name (specified between the & characters) is longer than the allowable 4 characters.
- E410      **INVALID VARIABLE NAME name**  
This indicates a mismatch between the variable name used on an 847 minor option and field 3 on the preceding 848 minor option.
- E411      **NO SPACE FOR BOX LENGTH**  
The length of the box defined on minor option 845 field 7 is greater than the drawing length.
- E412      **NO SPACE FOR BOX WIDTH**  
The width (height) of the box defined on minor option 845 field 10 is greater than the drawing width (height).
- E413      **OUT NOT ALLOWED WITH MIN-MAX BOX**  
This is reported when an attempt is made to use minor option 804 for plan drawing. Field 2 is 'OUT' and fields 5, 6, 8 and define a

min–max box. 'OUT' can only be used when a boundary string is referenced in field 3.

- E414           **REFERENCE STRING NOT FOUND FOR SECTION STRING label**  
The reference string defined from the subreference of the section string in field 1 of minor option 848 is not present in the model. The reference string defined from the subreference of the section string in Field 1 of minor option 848 is not present in the model. Check that you have coded the correct model name.
- E415           **DIMENSION number INVALID FOR SECTION STRING label**  
Field 7 of minor option 848 is in error. This is either a string dimension or one of the following special values: -1, -2, -4 or -11.
- E416           **label IS NOT A SECTION STRING**
- E417           **THIS OPTION IS FOR SECTIONS ONLY**  
This follows an attempt to define a text variable via minor option 848 for a drawing type other than a section drawing.
- E418           No longer applies
- E419           **DIMENSION REQUESTED BY 810 OPTION EXCEEDS 15MAXIMUM**  
The value in field 4, minor option 810 specifies a dimension which exceeds the maximum allowed (15).

### **Major option VCUSP**

- E420           **LOCATION POINT DATA IN WRONG ORDER**  
The chainage of a location point is less than that of the previous point. The chainage of a location point is less than that of the previous location point.
- E421           **PERCENTAGE GRADE INCORRECT**
- E422           **START CH. BEFORE FIRST LOCATION PT.**
- E423           **FINISH CH. AFTER LAST LOCATION PT.**
- E424           **CHAINAGE number NOT FOUND**  
The specified, or chosen, start/finish point cannot be found on the stored alignment.



- E425            START CH. GREATER THAN FINISH CH.
- E426            STRING LABEL MUST START WITH M  
                  Vertical alignment options can only operate on master alignments.

### Major option HALGN - French errors

- E448            USE OF IMPERIAL UNITS INVALID
- E449            INVALID DESIGN SPEED
- E450            RADIUS BELOW ARP STANDARD FOR SPECIFIED DESIGN  
                  SPEED
- E451            ALTERNATIVE SOLUTION INVALID FOR  
                  CS ELEMENT
- E452            CANNOT HAVE DEFAULT A AND RL VALUES
- E453            CANNOT HAVE A AND RL VALUES IN ELEMENT DATA

### Major option VALGN

#### Incorrectly specified elements

There are various combinations of data which will cause errors and will not give a solution. The combinations which prevent a solution are listed in the following paragraphs and explanations given together with diagrams where appropriate.

Wherever there are two feasible solutions these are derived by taking a square root. Impossible solutions will occur where the square root of a negative number is required.

In those error messages where curve coefficients are given, the parameters of M value, curvature, level and grade on the specified curves may be calculated as follows:-

coefficients of curve A, B, C

$$\begin{aligned} M &= 20000 A \\ R &= 1/2A \\ Y &= Ax^2 + Bx + C \\ G &= 2Ax = B \end{aligned}$$

where

$$\begin{aligned} x &= \text{Chainage} \\ M &= \text{M value} \\ R &= \text{Radius of Curvature at the Vertex of the} \\ &\text{Curve} \\ Y &= \text{Level of the curvature at chainage } x \\ G &= \text{Grade of the curve at chainage } x \end{aligned}$$

Note that the C value as given in the error message is divided by 100 to bring it within a suitable numeric range.

The ranges of error numbers have been classified as follows:

461 – 465    General Errors  
466 – 469    Fixed Curve Errors  
470 – 479    Floating Curve Errors  
480 – 489    Free Curve Errors

For each error the first line reads:

E4xx            AAAA CURVE KK CANNOT BE FIXED.

where

4xx            =            Error Number  
AAAA          =            'blank', or 'FIX' or 'FLOAT' or 'FREE'  
dependent on the error number.  
KK             =            number of the element which cannot be  
fixed.

The element types are summarised in the following table.

Element Type	M	Point A		Point B		Point C		
		X	Y	X	Y	X	Y	G
Fix 1.		X	X	X	X	X	X	
Fix 2.	X	X	X	X	X			
Fix 3.	X	X	X			X		X
Fix 4.		X	X	X	X	X		X
Fix 5.	X					X	X	X
Float 1.		X	X	X	X			
Float 2.	X	X	X					
Float 3.		X	X			X		X
Float 4.	X					X		X
Free 1.	X							
Free 2.		X	X					
Free 3.						X		X

**General specification errors**

- E461 CURVE KK CANNOT BE FIXED  
M VALUE LESS THAN 0.01 BUT NOT ZERO**  
The M value specified is less than 0.01. Within the system, any radius greater than 999999.9 is considered a straight. A curve which has an M value less than 0.01 has a radius greater than 999999.9. Change the M value to either zero or a larger value. Corrective action is to change the M value to either zero or a larger value.
- E462 CURVE KK CANNOT BE FIXED  
CURVES number AND number ARE NOT TANGENTIAL.**  
This message will always be preceded by W452. A curve which is defined as fixed is adjacent to another fixed element and tangency conditions cannot be resolved as either or both curves are over defined. A curve which is defined as fixed is adjacent to another

fixed element and tangency conditions cannot be resolved as either or both curves are over defined.

The same error can occur for floating elements, when the floating element can be floated into either the curve before it or the curve after it.

The problem may be overcome by relaxing the fixity of the curve from either 'fix' to 'float' or from 'float' to 'free'.

◇ This message will always be preceded by W452.

The same error can occur for floating elements when the floating element can be floated into either curve before it or the curve after it.

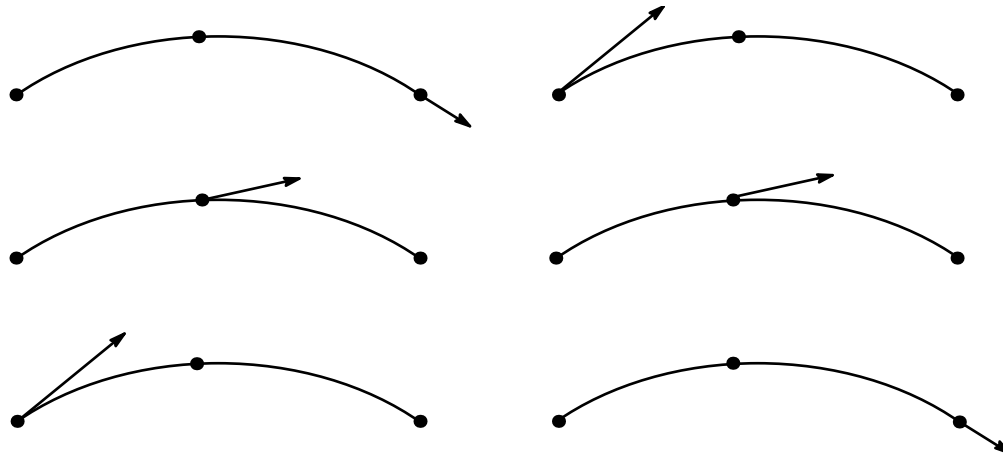
The problem may be overcome by relaxing the fixity of the curve from either 'fix' to 'float' or from 'float' to 'free'.

E463 CURVE KK CANNOT BE FITTED  
CURVE KK HAS OVERLAPPED PREVIOUS CURVE

E466 FIXED CURVE KK CANNOT BE FIXED  
GRADE CHAIN = AVERAGE POINT CHAIN

This error no. applies only to curve type FIX4 defined by two known points, chainage and gradient. The sign of the gradient is dictated by the direction of increasing chainage. The data may be specified in any sequence as illustrated in the following sketches by the x3 must locate the gradient. Midway between any two points the gradient of any vertical curve will be the same as the gradient between the two points and the curve has therefore any number of solutions. Movement of any of the two points should remove the problem. This error only occurs with a fixed vertical element defined by two points, chainage and gradient.

The chainage at which the gradient is specified (ie, Point C) must not be exactly midway between the other two points (ie, Point A and Point B). Modify the chainage of one of the points so that Point C is not at the midpoint.

**Example of E466****E467****FIXED CURVE KK CANNOT BE FIXED  
POINTS DEFINED AT SAME CHAINAGE number**

No two points defining levels in the specification of an element. No two points used in the specification of an element may have the same chainage.

**Floating elements**

With the exception of float curve type FLOAT 4, there are always two feasible solutions, derived by taking a square root. Whenever a square root of a negative number is required there will be an impossible solution and the cause of this will normally be incorrectly specified data.

**E470****FLOAT CURVE KK CANNOT BE FIXED  
FIXITY CONDITIONS**

This error will occur then there is no curve, which has been fixed (either by data or by calculation), for the floating curve to be tied into. Unless there is an unacceptable combination of fixed floating, and free curves, this error will be preceded by another error for some other element. If the other curve is corrected the problem will usually be resolved. This error occurs when there is no curve which has been fixed (either by data or by calculation), for the floating to be tied into. Unless there is an unacceptable combination of fixed, floating and free curves, this error will be preceded by another error for some other element. If the other curve is corrected, the problem will usually be resolved.

**E471****FLOAT CURVE KK CANNOT BE FIXED  
IDENTICAL M VALUES**

Two consecutive elements may not have the same M value or radius since then they are either identical and one curve is redundant, or they are parallel or alongside each other, in which case they are not tangential. elements may not have the same M values since then they are either identical and one curve is redundant, or they are parallel or alongside each other, in which case they do not tangent one another.

**E472**            **FLOAT CURVE KK CANNOT BE FIXED  
POINTS DEFINED AT SAME CHAINAGE** number  
No two points used in the specification of an element may have the same chainage.

**E473**            **FLOAT CURVE KK CANNOT BE FIXED  
POINTS label SIDE OF FIXED CURVE  
COEFS CURVE II M+MMMM –AAA  
\*CHAIN\*\*2 \*CHAIN CON/100  
A :B :C  
CHAINAGE LEVEL DEF LEVEL  
X1 :YY1 :Y1  
CHAINAGE LEVEL DEF LEVEL  
X2 :YY2 :Y2**

The curve to be resolved is a float type curve type 1 defined by 2 points. The information given in the error message is as follows: The curve to be resolved is a floating element defined by two points. The error occurs when the two specified points lie on opposite sides of the fixed curve so that the float curve and the fixed curve cannot be tangential to one another. It will usually be fairly obvious which point is in error from a knowledge of the magnitude of the level differences.

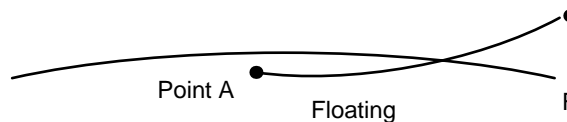
**II**                – the fixed curve to which the float curve is fixed.  
**MMMM**        – the M value of the fixed curve.  
**AAA**            – either STR/HOG/SAG description of the fixed curve.

**A**                – the coefficients of the fixed curve  
**B**  
**C**

**X1**              – chainage of first defined point  
**XY1**            – level of the fixed curve at chainage X1  
**Y1**              – level defined for floating curve at chainage X1

**X2**              – chainage of second defined point.  
**YY2**            – level on the fixed curve at chainage X2  
**Y2**              – level defined for floating curve at chainage X2

The error occurs when the two specified points lie on opposite sides of the fixed curve so that the float curve and the fixed curve cannot tangent one another. It will usually be fairly obvious which point is in error from a knowledge of the magnitude of the level differences.



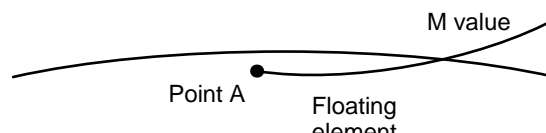
**Figure A - 5 Example of E473**

E474

**FLOAT CURVE KK CANNOT BE FIXED  
POINTS label SIDE OF FIXED CURVE  
M VALUE = number OPP. SIGN.**

The curve to be resolved is a floating element defined by one point and an M value or radius.

This error occurs when the defined point lies within the fixed curve and the M value or radius is of opposite sign to that of the fixed curve.



**Figure A - 6 Example of E474**

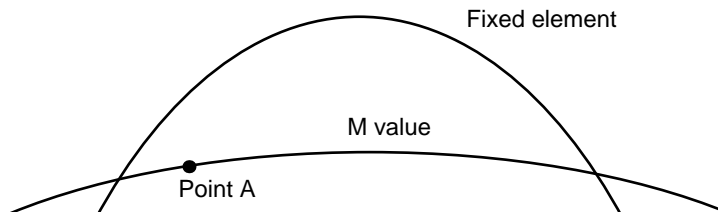
By making the level difference zero between the fixed curve and the floating curve at the defined point, the defined point effectively becomes the tangent point of the two curves. Change the level of the specified point or change the sign of the M value or radius.

E475

**FLOAT CURVE KK CANNOT BE FIXED  
POINTS label SIDE OF FIXED CURVE  
M VALUE = number SAME SIGN  
BUT label IN MAGNITUDE.**

The curve to be resolved is a floating element defined by one point and an M value or radius.

This error occurs when the defined point lies within the fixed curve and the M value is of the same sign as the fixed curve but is smaller in magnitude (or the radius is larger).



**Figure A - 7 Example of E475**

By making the level difference zero between the fixed curve and the floating curve at the defined point, the defined point effectively becomes the tangent point of the two curves. Change the level of the specified point or increase the M value.

E476

```
FLOAT CURVE KK CANNOT BE FIXED
PNTS label SIDE OF FIXED CURVE
M VALUE = number SAME SIGN
COEFS CURVE II M=M2M2-AAA
*CHAIN**2 *CHAIN CON/100
X1      :YY1      :Y1
CHAINAGE LEVEL DEF LEVEL
X2      :YY2      :Y2
```



The curve to be resolved is a float curve type 2 defined by one point and M value. The information given following each of the above is as follows:

```
COEFS CURVE II M=MMMM           -AAA
*CHAIN**2 *CHAIN CON/100
X1           :YY1           :Y1
CHAINAGE LEVEL DEF LEVEL
X2           :YY2           :Y2
```

II – the element no. of the fixed curve to which the float curve needs to be fixed.

MMMM – the M value of the fixed curve.

AAA – either 'STR' or 'HOG' or 'SAG'; description of the fixed curve.

A,B,C the coefficients of the fixed curve.

X1 – chainage of the defined point

YY1 – level on the fixed curve at chainage X1

Y1 – level defined for the floating curve at chainage

X1. The curve to be resolved is a floating element defined by one point and an M value or radius.

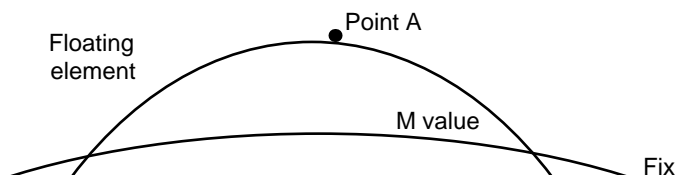
The error occurs when the defined point lies outside the fixed curve and the M value is of the same sign as the fixed curve but is greater in magnitude (or the radius is smaller).

E474 Occurs when the defined point lies within the fixed curve and the M value is of opposite sign to that of the fixed curve.

<0

>0

### Example of E474



**Figure A - 8 Example of E476**

By making the level difference zero between the fixed curve and the floating curve at the defined point, the defined point effectively becomes the tangent point of the two curves. Change the level of the specified point or decrease the M value (or increase the radius).

E475

Occurs when the defined point lies within the fixed curve and the M value is of the same sign as the fixed curve but is smaller in magnitude.

<0

0

### Example of E475

E476

Occurs when the defined point lies outside the fixed curve and the M value is of the same sign as the fixed curve but is greater in magnitude.

>0

:0

### Example of E476

By making the level difference, between the fixed curve and the floating curve at the defined point, zero the defined point effectively

becomes the tangent point of the two curves, and this should suggest the appropriate remedial action. In the above diagram this means setting the value of K, to zero.

E477 There are eight variations of this error which are all explained below, together with diagrams.

E477 FLOAT CURVE KK CANNOT BE FIXED  
POINTS label SIDE FIXED CURVE  
PNT. CHAIN label GRADE CHAIN  
GRADE label FIXED CURVE GRADE

The curve to be resolved is a float curve type 3 defined by one point, chainage and gradient.

The information given in the error message is as follows:

```
COEFS CURVE II M=MMMM           -AAA
*CHAIN**2 *CHAIN CON/100
X1           :YY1           :Y1
CHAINAGE LEVEL DEF LEVEL
X2           :YY2           :Y2
CHAINAGE GRADE DEF GRADE
X2           :GG2           :G2
```

II – the element no. of the fixed curve to which the float curve needs to be fixed.

MMMM – the M value of the fixed curve.

AAA – either 'STR' or 'HOG' or 'SAG'; description of the fixed curve.

A,B,C –the coefficients of the fixed curve.

X1 – chainage of the defined point

YY1 – level on the fixed curve at chainage X1

Y1 – level defined for the floating curve at chainage X1.

X2 – chainage of the defined grade.

GG2 – grade of the fixed curve at chainage X2

G2 – grade defined for the floating curve at chainage X2

In the diagrams which follow the range within which an error will occur is shaded.

The curve to be resolved is a floating element defined by one point, chainage and gradient.

An error occurs if the following conditions are true:

1. the specified point lies within the fixed curve AND
2. the chainage of the specified point is less than that of the specified chainage AND
3. the specified gradient is greater than (hog curves) or less than (sag curves) the gradient of the fixed curve at the specified chainage.

OR

1. the specified point lies within the fixed curve AND
2. the chainage of the specified point is greater than that of the specified chainage AND
3. the specified gradient is less than (hog curves) or greater than (sag curves) the gradient of the fixed curve at the specified chainage.

OR

1. the specified point lies outside the fixed curve AND
2. the chainage of the specified point is less than that of the specified chainage AND
3. the specified gradient is less than (hog curves) or greater than (sag curves) the gradient of the fixed curve at the specified chainage.

OR

1. the specified point lies outside the fixed curve AND
2. the chainage of the specified point is greater than that of the specified chainage AND
3. the specified gradient is greater than (hog curves) or less than (sag curves) the gradient of the fixed curve at the specified chainage.

1. the specified point lies within the fixed curve AND

E477

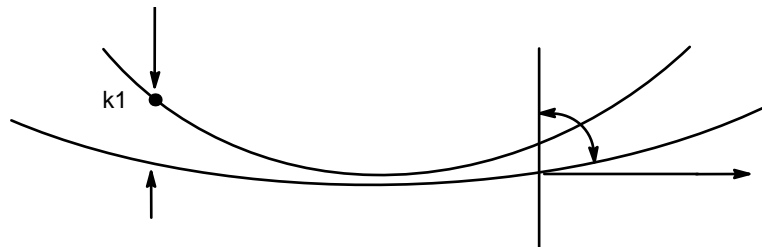
FLOAT CURVE KK CANNOT BE FIXED  
POINTS label SIDE FIXED CURVE  
PNT. CHAIN label GRADE CHAIN  
GRADE label FIXED CURVE GRADE

1

1

**Example of E477 PNTS INSIDE CHAIN = L.T. GRADE = G.T.**

E477 FLOAT CURVE KK CANNOT BE FIXED  
POINTS label SIDE FIXED CURVE  
PNT. CHAIN label GRADE CHAIN  
GRADE label FIXED CURVE GRADE



**Example of E477 PNTS INSIDE CHAIN = L.T. GRADE = L.T.**

E477 FLOAT CURVE KK CANNOT BE FIXED  
POINTS label SIDE FIXED CURVE  
PNT. CHAIN label GRADE  
CHAIN GRADE label FIXED CURVE GRADE

?

2

**Example of E477 PNTS INSIDE CHAIN = G.T. GRADE = G.T.**

E477      FLOAT CURVE KK CANNOT BE FIXED  
            POINTS label SIDE FIXED CURVE  
            PNT. CHAIN label GRADE  
            CHAIN GRADE label FIXED CURVE GRADE

2

|

**Example of E477 PNTS INSIDE CHAIN = G.T. GRADE = L.T.**

E477            FLOAT CURVE KK CANNOT BE FIXED  
                 POINTS label SIDE FIXED CURVE  
                 PNT. CHAIN label GRADE  
                 CHAIN GRADE label FIXED CURVE GRADE

**1**

**Example of E477 PNTS OUTSIDE CHAIN = L.T.  
GRADE = G.T.**

E477            FLOAT CURVE KK CANNOT BE FIXED  
                 POINTS label SIDE FIXED CURVE  
                 PNT. CHAIN label GRADE  
                 CHAIN GRADE label FIXED CURVE GRADE



1

**Example of E477 PNTS OUTSIDE CHAIN = L.T.  
GRADE = L.T.**

E477            FLOAT CURVE KK CANNOT BE FIXED  
                 POINTS label SIDE FIXED CURVE  
                 PNT. CHAIN label GRADE  
                 CHAIN GRADE label FIXED CURVE GRADE

i2

**Example of E477 PNTS OUTSIDE CHAIN = G.T.  
GRADE = G.T.**

E477            FLOAT CURVE KK CANNOT BE FIXED  
POINTS label SIDE FIXED CURVE  
PNT. CHAIN label GRADE  
CHAIN GRADE label FIXED CURVE GRADE

12

**Example of E477 PNTS OUTSIDE CHAIN = G.T.  
GRADE = L.T.**

E478            FLOAT CURVE KK CANNOT BE FIXED  
COINCIDENT CURVES.

This error occurs for floating element defined by one point, chainage and gradient. Curve type 3 when the curve is defined by one point, and chainage and gradient.

The cause of the error is that the chainage for the gradient is at the same chainage as for the defined point and the defined level is the same as the level at that chainage on the fixed curve.

The cause of the error is that the chainage for the gradient is at the same chainage as for the defined point and the defined level is the same as the level at that chainage on the fixed curve.

**Free elements**

There are two feasible solutions for each of the free elements and similar to the floating elements they are derived by taking a square root. If the term for which the square root is negative no real solution exists and an error is caused.

For the free elements curves which are fixed must lie to either side of the free element and it is the mutual arrangement of these fixed curves which dictates the permissible range of data values. If the two fixed curves intersect the permissible range of data values are in fact the exact opposite of the range when the curves do not intersect.

In the diagrams which follow the permissible ranges of solution are illustrated by dashed lines.

**E480 FREE CURVE KK CANNOT BE FIXED  
FIXITY CONDITIONS.**

This error will occur when there is no curve, which has been fixed (either by data or by calculation) either on one side or on both sides, of the free curve, such that tangency conditions cannot be met. Unless there is an unacceptable combination of fixed, and free curves, this error will be preceded by another error for some adjacent element. Should this adjacent element be corrected the problem will usually be resolved. This error occurs when there is no curve which has been fixed (either by data or by calculation), either on one side or on both sides of the free curve, such that tangency conditions cannot be met. Unless there is an unacceptable combination of fixed, and free curves, this error will be preceded by another error for some adjacent element. If this adjacent element is corrected the problem will usually be resolved.

**E481 FREE CURVE KK CANNOT BE FIXED  
IDENTICAL M VALUES.**

Two consecutive elements may not have the same M values since they are either identical and one curve is redundant, or they are parallel or alongside each other, in which case they do not touch one another. Two consecutive elements may not have the same M values since they are either identical and one curve is redundant, or they are parallel or alongside each other, in which case they are not tangential.

**E482 FREE CURVE KK CANNOT BE FIXED  
FIXED CURVES DON'T INTERSECT  
M VALUE = number OUTSIDE RANGE.**

The curve to be resolved is a free curve defined by M value or radius. This error occurs when the two fixed curves do not intersect but the specified M value or radius of the free curve lies between the M values of the fixed curves.

E483

FREE CURVE KK CANNOT BE FIXED  
FIXED CURVES INTERSECT  
M VALUE = number INSIDE RANGE.

The curve to be resolved is a free curve defined by M value or radius. This error occurs when the two fixed curves do not intersect and the specified M value or radius of the free curve lies between the M values of the fixed curves.

The curve to be resolved is a free curve type 1 defined by M value. The information given following each of the above errors is as follows:

```
COEFS CURVE II M=M1M1           -A1A1
*CHAIN**2 *CHAIN CON/100
A1           :B1           :C1           :
COEFS CURVE JJ M = M2M2 -A2A2
*CHAIN**2 *CHAIN CON/100
A2           :B2           :C2           :
```

II – the element no. of the fixed curve to which the float curve needs to

be fixed.

M1M1 – the M value of the fixed curve.

A1A1 – either 'STR' or 'HOG' or 'SAG'; description of the fixed curve.

A1,B1,C1 – the coefficients of the fixed curve 11.

JJ – the element no. of the fixed curve following the free curve

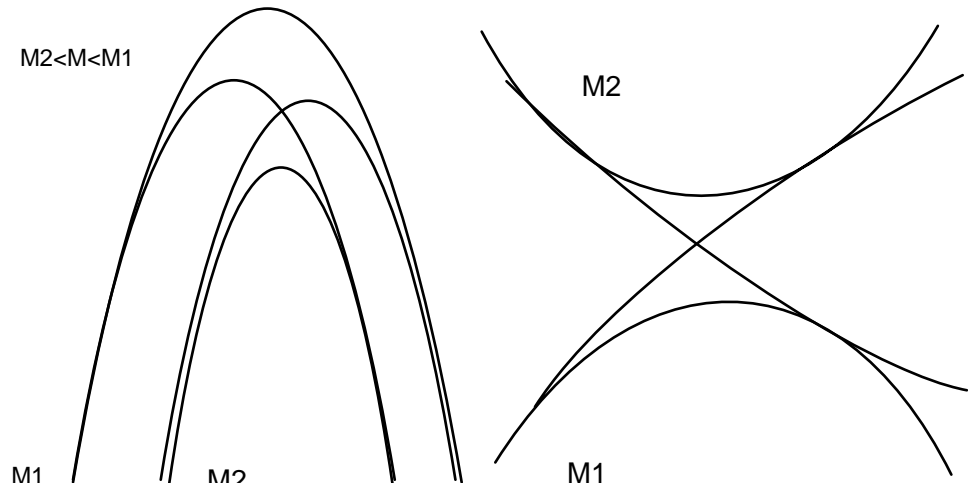
M2M2 – the M value of the fixed curve JJ

A1A1 – either 'STR' or 'HOG' or 'SAG'; description of the fixed curve JJ.

A2,B2,C2 – the coefficients of the fixed curve JJ.

E482

Occurs when the two fixed curves do not intersect and the M value of the free curve does not lie between the M value of the fixed curves. The following diagram illustrates the feasible range of solutions.

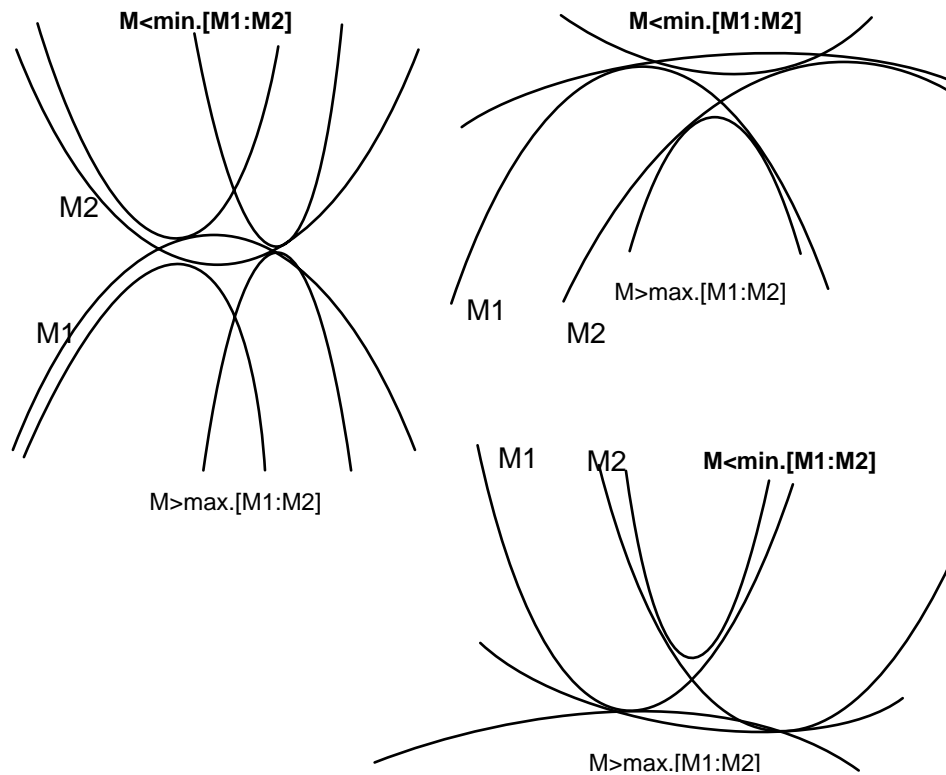


Example of E482 non-intersecting curves

E483

Occurs when the two fixed curves do not intersect but the M value of the free curve lies between the M values of the fixed curves. The following diagram illustrates the feasible range of solutions:

Intersecting curves



Example of E483 intersecting curves

E484 FREE CURVE KK CANNOT BE FIXED  
FIXED CURVES DON'T INTERSECT  
POINT OUTSIDE FIXED CURVES

E484 FREE CURVE KK CANNOT BE FIXED  
FIXED CURVES DON'T INTERSECT  
POINT OUTSIDE FIXED CURVES

The curve to be resolved is a free curve defined by one known point. This error occurs when the two fixed curves do not intersect and the specified point does not lie between the two fixed curves.

E485 FREE CURVE KK CANNOT BE FIXED  
FIXED CURVES INTERSECT  
POINT BETWEEN FIXED CURVES

The curve to be resolved is a free curve defined by one known point. This error occurs when the two fixed curves intersect but the specified point lies between the two fixed curves.

The curve to be resolved is a free curve type 2 defined by one known point. The information given following each of the above errors is as follows:

```
COEFS CURVE II M=M1M1          -A1A1
*CHAIN**2 *CHAIN CON/100
A1          :B1          :C1          :
CHAINAGE LEVEL DEF LEVEL
X1          :YY1         :Y1          :
COEFS CURVE JJ M = M2M2 -A2A2
*CHAIN**2 *CHAIN CON/100
A2          :B2          :C2          :
CHAINAGE LEVEL DEF LEVEL
X2          :YY2         :Y2          :
```

II – the element no. of the fixed curve to which the float curve

needs to be fixed.

M1M1 – the M value of the fixed curve.

A1A1 – either 'STR' or 'HOG' or 'SAG'; description of the fixed curve.

A1,B1,C1 – the coefficients of the fixed curve 11.

X - chainage of the defined point

YY1 – level on the fixed curve !! at chainage X

Y – level defined for the free curve at chainage X.

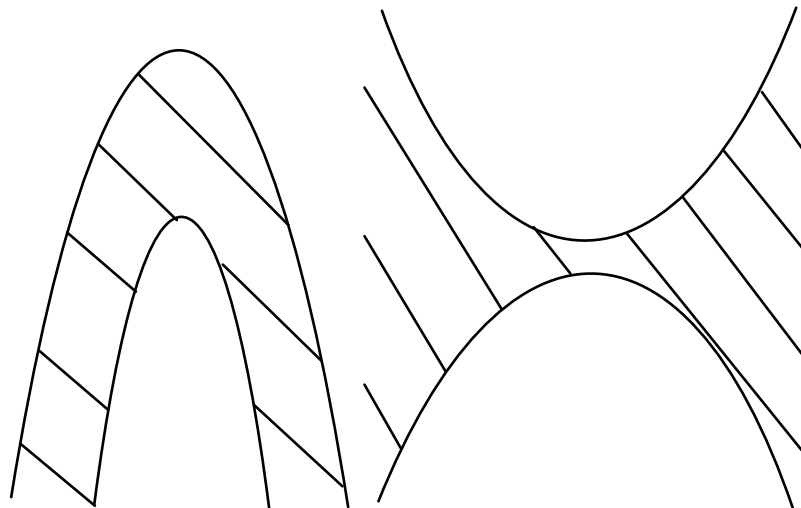
JJ – the element no. of the fixed curve following the free curve

M2M2 – the M value of the fixed curve JJ

- A2A2 – either 'STR' or 'HOG' or 'SAG'; description of the fixed curve JJ.  
A2,B2,C2 – the coefficients of the fixed curve JJ.  
X – chainage of the defined point  
YY2 – level on the fixed curve JJ at chainage X  
Y – level defined for the free curve at chainage X

E484 occurs when the two fixed curves do not intersect and the defined point does not lie between the two fixed curves. In the following diagram the feasible area for the position of the known point is shaded.

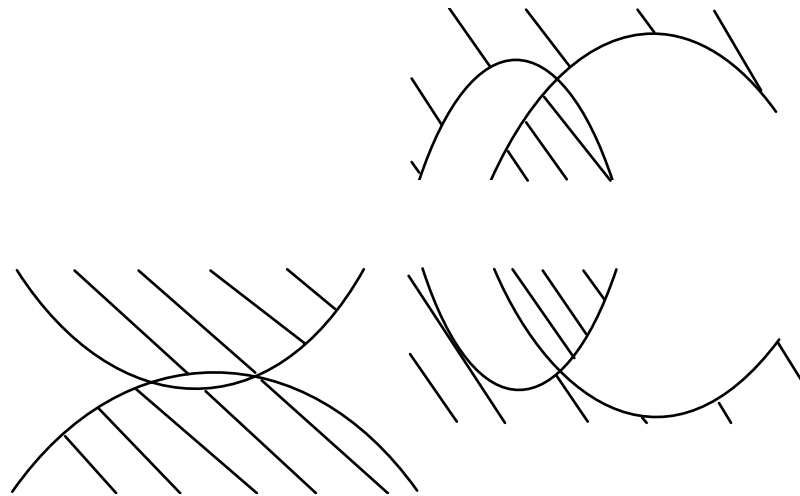
Non-intersecting curves



**Example of E484 non-intersecting curves**

- E485 Occurs when the two fixed curves intersect but the defined point lies between the two fixed curves. In the following diagram the feasible area for the position of the known point is shaded.

Intersecting curves



### Example of E485 intersecting curves

E486

**FREE CURVE KK CANNOT BE FIXED  
FIXED CURVES DON'T INTERSECT  
GRADE OUTSIDE RANGE**

The curve to be resolved is a free curves defined by chainage and gradient. The feasible range of direction for specified gradient varies as the defined chainage moves along the chainage axis and although the range may be mathematically calculated, the feasible range cannot be easily illustrated graphically. However, the cause of any error is again dependent on whether the two fixed curves associated with the free curve intersect.

It is recommended that unless the chainage point or gradient may be modified easily, another of the methods for defining the free curve is used.

E487

**FREE CURVE KK CANNOT BE FIXED  
FIXED CURVES INTERSECT  
GRADE INSIDE RANGE**

The curve to be resolved is a free curve defined by chainage and gradient. The feasible range of direction for specified gradient varies as the defined chainage moves along the chainage axis and although the range may be mathematically calculated, the feasible range cannot be easily illustrated graphically. However, the cause of any error is again dependent on whether the two fixed curves associated with the free curve intersect.



The curve to be resolved is a free curve type 3 defined by chainage and gradient. The information given following each of the above errors is as follows:

```
COEFS CURVE OO – M1M1           –A1A1
*CHAIN**2 *CHAIN CON/100
A1           :B1           :C1           :
CHAINAGE LEVEL DEF LEVEL
X1           :Y1           :G1           :
COEFS CURVE II M = M2M2 –A2A2
*CHAIN**2 *CHAIN CON/100
A2           :B2           :C2           :
CHAINAGE LEVEL DEF LEVEL
X2           :Y2           :G2           :
RANGE = R1R1           :R2R2           :
DEF.GRADE = G.
```

- II – the element no. of the fixed curve previous to the free curve.
- M1M1 – the M value of the fixed curve 11.
- A1A1 – either 'STR' or 'HOG' or 'SAG'; description of the fixed curve
- II.
- A1,B1,C1 – the coefficients of the fixed curve II.
- X1 – defined chainage
- Y1 – level on the fixed curve II at chainage X
- G1 – grade on the fixed curve at chainage X.
- JJ – the element no. of the fixed curve following the free curve
- M2M2 – the M value of the fixed curve JJ
- A2A2 – either 'STR' or 'HOG' or 'SAG'; description of the fixed curve JJ.
- A2,B2,C2 – the coefficients of the fixed curve JJ.
- X2 – chainage of the defined point
- Y2 – level on the fixed curve JJ at chainage X
- G2 – level defined for the free grade on the fixed curve JJ at chainage X
- R1R1,R2R2 – the range inside/outside which the gradient must lie for a solution to exist if the curves do not intersect/do intersect
- (E486/E487)
- G – the defined gradient

The feasible range of direction for specified gradient varies as the defined chainage moves along the chainage axis and although the range may be mathematically calculated the feasible range cannot be easily illustrated graphically. However, the cause of any error is again dependent on whether the two fixed curves associated with the free curve, intersect.

It is recommended practice that unless the chainage point or gradient may be easily modified another of the methods for defining the free curve is used.

**E488 FREE CURVE KK CANNOT BE FIXED  
COINCIDENT CURVES**

The fixed curve to either side of the free curve is in fact the same curve so that some of the data is redundant. This error may occur for any of the three curve types. The fixed curve to either side of the free curve is in fact the same curve so that some of the data is redundant. This error may occur for any type of free curve.

**E489 FREE ARC WITH ADJACENT ARC OF OPPOSITE HAND NOT  
ALLOWED**

**E490 FREE CURVE number CANNOT BE FIXED  
FIXED CURVES INTERSECT  
POINT LIES AT INTERSECTION**

**E491 COINCIDENT CHAINAGES CALCULATED**

**E492 GEOMETRY STRING ALREADY HAS VERTICAL POINTS**

**E493 NO HORIZONTAL GEOMETRY STRING**

**E494 COINCIDENT POINTS - LEVELS NOT APPLIED TO GEOMETRY  
STRING**

**Major option DIGIT**

**E500 FOLLOWING TRANSPOSITION POINT  
IS THREE TIMES THE STANDARD ERROR  
TABLE X1X1 Y1Y1  
TRUE X2X2 Y2Y2  
TRANSPOSED X3X3 Y3Y3**

The transformation between two sets of coordinate systems (table and true) has been calculated such that the mentioned point has transformed coordinates greatly different from the coordinates as defined. One or other of the coordinates will have been wrongly specified and the offending values will usually be obvious. The

coordinates for the point may be corrected or even removed from the data.

- E501      **THE RESIDUAL ERROR EXCEEDS number**  
The number is a value defined in the initial data. In addition to assessing the magnitude of the errors compared to the standard error, the absolute magnitude of the error is larger than that defined in the initial data (default value 1.0). An error is caused.
- E502      **NO. OF TRANSFORMATION POINTS  
INSUFFICIENT**  
To enable the transformation to be calculated there is a minimum requirement of 2 points and a maximum of 9 transformation points.
- E503      **MUST BE 4 BLOCK CONTROL POINTS**
- E504      **BLOCK CO-ORDINATES ARE IN ERROR**
- E505      **SCALE FACTOR(S) EXCEED(S)  
TOLERANCE**
- E506      **SQUARENESS OF TABLE CO-ORDINATES  
EXCEEDS TOLERANCE**
- E507      **CORRUPT DISCONTINUITY IN STRING label**

#### **Major option GENIO errors**

- E510      **CANNOT APPEND TO CADASTRE STRING - INCOMPATIBLE  
SUBREFERENCE**
- E511      **FEATURE CODE MUST BE 4 CHARACTERS**
- E512      **SURVEY POINT NUMBER MUST NOT EXCEED 8 CHARACTERS**
- E513      **CADASTRE POINT NUMBER MUST NOT EXCEED 16  
CHARACTERS**

#### **Major option SURVEY**

- E520      **INSTRUMENT SET UP RECORD  
IS MISSING OR INVALID**  
An Instrument Set Up record must precede the first observation record.
- E521      **STATION NOT FOUND**

- E522            DISCREPANCY IN STADIA READINGS  
The differences in levels between the top/middle and the middle/bottom do not match.
- E523            INSTRUMENT HEIGHT NOT PROVIDED
- E524            INVALID COMBINATION OF DATA
- E525            NEGATIVE CO-ORDINATES CALCULATED
- E526            label INDICATOR EXPECTED  
A TIE, PIV, or LNE indicator was specified on the previous record but the present record does not contain the associated indicator TIE, LNE or PIV.
- E527            MAXIMUM ALLOWED ERROR EXCEEDED  
The specified, or default, traverse linear error has been exceeded.
- E528            UNEXPECTED VERTICAL ANGLE FOR THEODOLITE  
CONSTANTS  
The slope angle is very steep. Suspect a wrong vertical angle datum specification on the station set up record.
- E529            STATIONS STRING CAN ONLY BE GIVEN  
ONCE, label USED  
Only one stations string can be used in a single run of SURVEY. Two labels have been given on different 017 options.
- E530            CANNOT SPECIFY STATION STRING AFTER  
180 OPTION, label USED  
An 017 option has been coded after the first 180 option. The program must know the label of the stations string before any 180 option. Minor option 017 has been coded after the first minor option 180 command. You must specify minor option 017 before minor option 180, so that the program knows the label of the stations string.
- E531            ONLY ONE 189 OPTION ALLOWED  
The contents coded on the 189 option are used for processing all the data. It is not possible to change the value during a run. The survey constants coded using minor option 189 can only be specified once in any run of major option SURVEY.
- E532            CALCULATION NEEDS AT LEAST  
3 OBSERVATIONS

At least three observations are needed to calculate coordinates of a station by intersecting rays or resectioning. At least three observations are needed to calculate coordinates of a station by intersecting rays or resectioning. Check that you have specified the correct number of minor option 201/202 commands.

- E533            DATA CONTAINS COINCIDENT POINTS  
More than one observation has been made to a station for intersecting rays or resectioning. Check that you have coded the correct names in minor option 201/202. This probably due to a label having been coded wrongly on one of the observation codes.
- E534            DATA CONTAINS COLLINEAR POINTS  
The first three points in a set of observations for intersecting rays or resectioning lie on a straight line. This prevents the program from calculating an approximate point at the beginning of the analysis.
- E535            PIV AND LNE POINTS COINCIDE
- E536            TIE OBSERVATIONS DO NOT INTERSECT
- E537            EQUAL CHAINAGES ON TIE OBSERVATIONS
- E538            TRAVERSE OBSERVATIONS NOT INPUT  
IMMEDIATELY AFTER THE 200 RECORD  
Observations which are part of the traverse can be mixed with detail observations but all the traverse observations must appear immediately after the 200 option.
- E539            STATION label NOT DEFINED  
The station specified cannot be used. Possible causes are that the station is not in the stations string or that an attempt to calculate the station earlier in the run has failed.
- E540            CANNOT RECALL POINT REQUIRED  
The point number given in field 10 has not been coded on an earlier observation or does not lie in one of the sequences of point numbers generated by the program.
- E541            INVALID OBSERVATION RECALLED  
The observation requested cannot be recalled because it contains data errors.
- E542            OBSERVATION REQUESTED IS OF WRONG  
TYPE FOR RECALL

The observation requested cannot be recalled because the record does not contain a basic observation eg it is an offset or a taped observation. The observation requested cannot be recalled because the record does not contain a basic observation. Check that the observation is not an offset or a taped observation.

E543

**EXTENSION NOT ALLOWED ON  
NON GEOMETRIC OBSERVATION**

Extensions are not only relevant to geometric observations. They cannot be used for 3–stadia, chain and offset, or real observations. Extensions are only relevant to geometric observations. They cannot be used for 3-stadia, chain and offset, or real observations.

E544

**ONLY PREVIOUS OBSERVATIONS  
MAY BE EXTENDED**

E545

**ERROR IN DISCONTINUITY**

E546

**MORE THAN number OFFSET STRINGS**

E547

**CANNOT USE STATION label.  
CONFLICT IN STATION RANKING**

The order of station ranking is traverse, intersecting rays, resection and fly stations. An attempt has been made to calculate a station by sighting to a station which is itself to be calculated in the run – but by a method lower down the order of priority eg data for resectioning contains a sighting to a fly station.

E548

**ERROR CALCULATING STATION label.  
STATION NOT CREATED**

The program has detected an error in the mathematical analysis of the intersecting ray or resectioning data. The program cannot recover from the error and a solution cannot be calculated. Please contact your MOSS support staff.

E549

**UNRECOVERABLE ERROR IN ANALYSIS**

The program has detected an error in the mathematical analysis of the intersecting ray or resectioning data. The program cannot recover from the error and a solution cannot be calculated. Please contact your MOSS support staff.

E550

**MORE THAN number INSTRUMENT STATIONS  
IN THIS RUN**

- E551            MORE THAN number OBSERVATIONS  
FOR STATION label
- E552            STATION CANNOT BE RESECTIONED  
FROM MORE THAN ONE SET UP  
A station which is to be calculated by resectioning has been  
specified as the set up station on more than one 200 option. All  
observations for a resectioning analysis must be taken from a single  
set up.
- E553            CANNOT DELETE AND RECREATE A  
STATION AFTER FIRST 200 RECORD  
If 180 options are to delete/amend stations they should be coded  
before the first 200 option.If you wish to delete or amend stations  
using minor option 180, you should do so before coding the first  
minor option 200 command.
- E554            CANNOT CREATE/AMEND A STATION  
MORE THAN ONCE  
An attempt has been made to define a station more than once  
during the run. This cannot be allowed since all the observations are  
read and stored within the program before any reduction of  
observations is carried out.
- E555            INVALID COLLIMATION DETAILS
- E556            MORE THAN number POINTS IN THIS RUN  
The data should be split into two runs, ie you should invoke major  
option SURVEY twice and specify a portion of the data in each run..
- E557            IGLL USED WITHOUT STRING LABEL
- E558            NO VALID FEATURE CURRENT LABEL  
This is generated when an observation has no label coded and  
there are data errors on the earlier record which defines the label for  
the string.
- E559            NO OBSERVATION TO OFFSET FROM
- E560            CANNOT OFFSET FROM INVALID POINT  
The calculation of the previous point has failed due to data errors.
- E561            CANNOT OFFSET FROM A ONE PT STRING  
The direction for an offset is at right angles to a link on the reference  
string. Hence no direction can be determined for a one point string.

- E562            ATTEMPT TO OFFSET FROM A LINK  
CONTAINING TAPED OR OFFSET POINT.
- E563            STRING LINK TOO SHORT FOR  
ACCURATE OFFSETTING  
The two points on the reference string which give the direction for  
calculating the offset are very close together.
- E564            STATION REFERENCED BY ANOTHER  
RECORD. CURRENT RECORD IGNORED  
An attempt has been made to calculate coordinates for a station  
more than once. The values from the first calculation will be used  
during the run but no results will be stored.
- E565            MORE THAN number STATIONS  
This is a limit on the number of stations which can be used in a  
single run SURVEY. There is no limit to the number of stations  
which can be stored in a stations string.
- E566            MORE THAN number SETUP RECORDS  
The data should be split into two runs.
- E567            MORE THAN number THEODOLITE RECORDS
- E568            NEGATIVE SEQUENCE NUMBER GIVEN
- E569            TAPE OBSERVATION NEEDS TWO  
PREVIOUS VALID OBSERVATIONS  
Taping is relative to the previous link on a string – two points are  
needed to define a link.
- E570            PREVIOUS OBSERVATIONS TOO CLOSE  
TO DEFINE DIRECTION FOR TAPING  
The two points defining the link to be taped from are very close  
together. Check that there was no error when – probably due to an  
error in recording the data.
- E571            ERRORS DETECTED – NO STRINGS STORED  
No strings are stored when errors are detected so that existing  
models are not updated incorrectly. All the errors have been  
indicated – they should be corrected and the data rerun.
- E572            TRAVERSE NOT CALCULATED DUE TO  
DATA VALIDATION ERRORS.



The errors will be indicated. They should be corrected and the data rerun.

- E573      BACKSIGHT FROM label IS NOT TO  
PREVIOUS SETUP STATION.  
See Chapter 5 for details of the observations to be taken for each  
instrument set up.
- E574      SETUP STATION label IS NOT THE  
PREVIOUS FORESIGHT STATION  
See Chapter 5 for details of the observations to be taken for each  
instrument set up.
- E575      FORESIGHT OMITTED FROM STATION label  
See Chapter 5 for details of the observations to be taken for each  
instrument set up.
- E576      DETAIL OBSERVATION PRECEDES  
TRAVERSE OBSERVATION FROM label  
Detail observations can be mixed with traverse observations but all  
the traverse observations must appear together immediately after  
the 200 option.
- E577      FORESIGHT FROM label IS NOT A  
FULL OBSERVATION  
Observation must contain horizontal angle, distance component and  
level component.
- E578      BACKSIGHT FROM label IS NOT A  
FULL OBSERVATION  
Observation must contain horizontal angle, distance component and  
level component.
- E579      BOTH BACKSIGHT AND FORESIGHT TO  
STATION label FROM STATION label.  
See Chapter 5 for details of the observations to be taken for each  
instrument set up.
- E580      BACKSIGHT/FORESIGHT RECORDS FROM  
label ARE INCONSISTENT.  
See Chapter 5 for details of the observations to be taken for each  
instrument set up.
- E581      FORESIGHT FROM label IS INVALID.  
label IS NOT DEFINED

See Chapter 5 for details of the observations to be taken for each instrument set up.

- E582            **SURPLUS TRAVERSE OBSERVATIONS AFTER  
END OF TRAVERSE DETECTED.**  
When an existing station is referenced in the traverse it indicates the end of the traverse. The remaining traverse records are checked and must conform to one of the end fixity methods.
- E583            **PARTIAL OBSERVATION FROM UNKNOWN  
STATION label TO ANOTHER STATION.**  
Partial observations (ie horizontal angle only) can only be taken when sighting onto an azimuth bearing and not onto a station.
- E584            **TRAVERSE OBSERVATIONS TO MORE THAN  
TWO STATIONS FROM STATION label.**  
See Chapter 5 for details of the observations to be taken for each instrument set up.
- E585            **ATTEMPT TO COLLIMATE FROM REFERENCE  
STATION.**  
Collimation from the reference station is not allowed from traverse or resection calculation.
- E586            **ATTEMPT TO MIX DETAIL OBSERVATIONS  
AND OBJECTS IN STRING label.**  
Objects are stored in strings in a special way and it is not possible to store ordinary points in the same string as objects.
- E587            **ANGULAR/DISTANCE ADJUSTMENT FOR  
label OBSERVATION IS TOO LARGE.**  
An individual observation is rejected if the error for the observation is significantly larger than the errors of other observations. However, if all the individual errors are comparable but an error is larger than the absolute limit the entire solution is still rejected.
- E588            **LEVEL ADJUSTMENT FOR label  
OBSERVATION IS TOO LARGE.**  
The solution is rejected if a level adjustment is larger than the absolute limit.
- E589            **SETUP AND OBSERVED STATIONS  
ARE IDENTICAL.**  
Same name has been coded in field 1 and field 2 on 200 option.

- E590            189 RECORD INPUT AFTER FIRST 200  
RECORD.  
The correction factors given on the 189 option need to know when a  
200 option is processed.
- E591            NEGATIVE COORDINATES INTERPOLATED  
ON CURVED SECTION OF STRING.  
The curve fitting algorithms have calculated a point with a negative x  
or y coordinate.
- E592            CONSECUTIVE, COINCIDENT POINTS ON  
CURVE.  
An attempt has been made to fit a spline curve through a section of  
string containing consecutive points with identical x and y  
coordinates. This is not possible.
- E593            SLOW CONVERGENCE. CHECK DATA FOR  
GROSS ERRORS.  
The least squares solution for resectioning / intersecting rays has  
exhibited slow convergence. Check that there are no excessive  
errors in the data. This only happens with one or more excessive  
errors in the data.
- E594            PARTIAL P STRINGS NOT ALLOWED

**Major option SECTION**

- E601            STRING label ALREADY EXISTS  
The section strings are already stored in the model.
- E602            LEFTMOST OFFSET GREATER THAN OR  
EQUAL TO RIGHTMOST OFFSET  
This refers to the section offsets specified for the minor option. The  
offsets may be on either side of the reference string or line or both to  
the left or right. The error usually occurs when equal offsets are  
specified to either side of the reference line or string and the left  
offset is not specified as a negative number.
- E603            CHAINAGE number DOES NOT EXIST  
Each section must pass through an existing point on the reference  
string.
- E604            MASTER ALIGNMENT NOT SPECIFIED  
Occurs with option 174 if a master alignment string is not specified.

- E605            LESS THAN 3 POINTS ON STRING  
Less than three points in the reference string and option unable to erect normal.
- E606            NUMBER OF SECTIONS EXCEEDS SECTION LABELLING CAPABILITY  
A set of sections is limited by the number of alphanumeric characters available in a string label. The maximum permissible number of sections is 46655. When generating sections from a reference string the point number on the reference string is used to label the section. If the section interval is greater than the interval of points on the string the intervening numbers will not be used.
- E607            ASSOCIATED POINT ON label FOR POINT number ON label NOT FOUND.
- E608            INTERSECTION WITH label NOT MADE – SECTION TOO NARROW.
- E609            WRONG REFERENCE STRING SPECIFIED  
When appending sections the same reference string must be used in both cases.
- E610            EXISTING SECTION DOES NOT END AT coordinates  
If appending long sections the start of an appended length must be at the exact end of an existing length.
- E611            CANNOT APPEND SECTIONS AFTER EXITING MAJOR OPTION
- E612            WRONG STRING LABEL SPECIFIED  
The same reference string must be used when appending new cross sections to an existing set of sections.
- E613            WRONG INITIAL CHARACTER SPECIFIED  
The same cross section set initial character must be used when appending cross sections.
- E614            REVERSE DIRECTION OF CHAINAGE
- E615            TOO MANY CROSS SECTIONS  
MAXIMUM ALLOWED = number

**Major option SETOUT**

- E650            **MAXIMUM NUMBER OF 400 POINTS  
IN STRING**  
The survey stations string (usually PSSA) is limited to containing 400 points. The solution is to either delete some of the stored stations which may now be redundant, or to re-define the stations string as say PSSB using minor option 017. The latter solution may not be practical since when setting out with respect to two stations, both must lie in the same station's string.
- E651            **FIRST REF. STATION NOT STORED**
- E652            **SECOND REF. STATION NOT STORED**  
The reference station as defined cannot be found within the station's string.
- E653            **NO STATION DATA AVAILABLE**  
A point data string does not exist nor have station points been processed prior to this option.
- E654            **INITIAL REF. STATION NOT DEFINED**  
Setting out by deflection angles requires a reference station and this has not been specified.

**Major option HAUL**

- E700            **MATERIAL TYPE MUST BE INTEGER  
IN RANGE number TO 5 INCLUSIVE.**  
Note; number will usually be 1). The material is referenced by an integer number in the range 1–5. However, when distributing proportions of cut amongst the other available material types, (option 073) the proportion relates to material 1 and in this instance the available range is 2–5.
- E701            **MINOR OPTION number NOT YET INVOKED.**  
Some of the Mass Haul minor options are complementary to others. For example the constituent volume strings of the scheme volume string (option 071) cannot be defined without having first defined the scheme volume string itself (option 070).  
Option 070 must occur before option 071.  
Option 072 must occur before options 073, 074, or 075.

- E702            SPECIFIED EXPORT VOLUME EXCEEDS  
VOLUME AVAILABLE AT CHAINAGE  
number
- E703            START/FINISH POINTS ARE IDENTICAL.  
An analysis cannot be carried out over a zero length range.
- E704            SUM OF PROPORTIONS EXCEEDS 1.0  
AT CHAINAGE number  
Minor option 073 allows the cut volume for material 1 to be distributed across the other material types. However, the ratios must sum to less than or be equal to 1.0  
ie  $PROP2 + PROP3 + PROP4 + PROP5 \leq 1.0$   
If the above sum is equal to 1.0 then there will be zero volume remaining of material type 1. If the sum is less than 1.0 then the residual will be material type 1.
- E705            FIELD number MUST BE IN THE PREVIOUS  
number OPTION OR BE BLANK.  
(options 070/071) The Reference String and the scheme volume string as defined on option 072 will be used for complementary options 073 or 074. If on the complementary options these fields (field 1 and 2) are coded then they must be in sympathy with the option 072.
- E706            IMPORT AND EXPORT CANNOT BOTH BE  
SPECIFIED AT THE SAME POINT.  
(Option 074) Fields (5,6) (input) and (8,9) cannot both define the same point, on the same record.  
Import and export can be specified on one record provided they are at different points.
- E707            EXPORT POINT NOT SUPPLIED.  
(Option 074) Fields 5 and 6 must be coded if field 7 (export quantity) is to be allocated.
- E708            IMPORT POINT NOT SUPPLIED.  
(Option 074) Fields 8 and 9 must be coded if field 10 (import quantity) is to be allocated.
- E709            FIELD 2 MUST CONTAIN A VOLUME  
STRING LABEL.  
(Option 072) A mass haul analysis must have a string containing volumes to analyse.

- E710**            **FIRST CHARACTER OF STRING LABEL  
MUST NOT BE ' M '**  
The prefix M is used to denote a master alignment and must not be used to identify mass haul strings.
- E711**            **POINT co-ordinates  
IS OUTSIDE RANGE OF label**  
Although the point exists on the reference string the volume string or the mass string does not extend over the full extent of the reference string. Consequently this point cannot be referenced for this analysis.
- E712**            **START POINT NUMBER MUST NOT BE  
HIGHER THAN END POINT NUMBER**  
It is not possible to carry out an analysis from a higher chainage to a lower chainage ie in a reverse direction.
- E713**            **STRING ALIGNMENTS ARE INCOMPATIBLE  
CHECK POINT NOS. AND COORDINATES**  
(Option 073) An individual volume string can only be referenced to the reference string which created it or to an alignment collinear with the original reference string and at the same interval. The individual string is compared with the scheme string to ensure that both have identical point over the specified range. A check should be made that sections have been created with option 174 and not 173.
- E714**            **VOLUME STRING label DOES NOT EXIST**  
Self explanatory. Was a volume string created within major option VOLUME using minor option 058?
- E715**            **VOLUME STRING label HAS NO POINTS**  
Self explanatory. Have options 071 been defined complementary to option 070?
- E716**            **POINT FOUND MUST BE AT EXACT  
CHAINAGE INTERVAL**  
(Option 070) Analyses may only sensibly be carried out between regular chainage intervals.
- E717**            **NO POINT ON REFERENCE STRING AT  
CHAINAGE number**  
The chainage point must be an exact point on the reference string. It only occurs if a chainage interval point is missing between the SPRD given.

- E718            NO VOLUMES DATA PROVIDED FOR  
SCHEME STRING  
Although option 070 has been defined no supporting options 071  
have been supplied.
- E719            MASS STRING MUST HAVE NO MORE  
THAN 1000 POINTS  
It is not possible to analyse more than 1000 chainage positions.  
For example at 20 metre intervals analyses can be carried out for  
schemes up to 20 kilometres, at 100 foot interval analyses can be  
carried out for schemes up to 18 miles.

**Major option INTERFACE**

- E764            'DATM' ONLY PERMITTED WITH 'ALTERNATIVE' STYLE  
INTERFACES E763        NEGATIVE OFFSET SPECIFIED  
OFFSET MUST BE POSITIVE
- E764            'DATM' ONLY PERMITTED WITH 'ALTERNATIVE' STYLE  
INTERFACES
- E765            OFFSETS DIFFER FOR STRING label  
A barrier string must be a constant offset from the level datum string  
in both cut and fill.
- E766            BARRIER STRING MUST BE CODED  
IN CUT AND FILL
- E767            ONLY 'IGN' STRINGS ALLOWED  
BETWEEN LDS AND BARRIER STRING  
A fixed ground profile is required up to the barrier string.
- E768            BARRIER STRING NOT ALLOWED WITH  
REVERSE CASE
- E769            CUT/FILL BARRIER INFORMATION  
INCONSISTENT  
The cut and fill data have either: different barrier strings coded, a  
mixture of 3D and 5D barrier strings or different surface height  
adjustments with a barrier string.
- E770            ONLY ONE BARRIER STRING ALLOWED
- E771            IDENTICAL START AND END LABELS



- E772            A DIFFERENT INITIAL CHARACTER MUST  
                 BE USED FOR EACH REPEAT PATTERN
- E773            REPEAT PATTERNS NOT ALLOWED WITH  
                 REVERSE CASE
- E774            'IGN' NOT ALLOWED IN REPEAT PATTERN
- E775            REPEAT PATTERN CHARACTER NOT GIVEN
- E776            NO POINTS FOUND FOR STRING  
                 STRING NOT STORED  
                 After having processed all the relevant ground information no  
                 interface points have been found and consequently the interface  
                 string has not been generated.
- E777            SUBREF STRING NOT FOUND  
                 The interface string is determined by using stored sections and it is  
                 the section string label which is defined in the option. However, the  
                 reference string from which the sections were created is held in the  
                 sub-reference of the section string. This reference string needs to  
                 be accessed to determine the normals on which each interface point  
                 lies. The error is often caused by wrongly defining the model names.
- E778            CANNOT MIX STORED AND AUTO SECTIONS
- E779            SECTION SET MUST BE ONE CHARACTER
- E780            STRING label NOT FOUND IN LIST
- E781            REFERENCE STRING DOES NOT EXIST  
                 The reference string, specified in field 1 of the 260 option, is not in  
                 the model as input on the major option.
- E782            START LABEL NOT PREVIOUSLY USED  
                 The label entered in field 2 of a 261/262 record must be either the  
                 level datum string or a string named in field 3 of the previous  
                 261/262. See Chapter 6 for further explanation.
- E783            REVERSE CASE NOT ALLOWED IN  
                 MULTI-STRATA SITUATION
- E784            REVERSE CASE DOES NOT ALLOW  
                 DUPLICATE LABELS IN FIELD 2
- E785            REVERSE CASE DOES NOT ALLOW  
                 DUPLICATE LABELS IN FIELD 3
-

- The use of optional slope conditions is not permitted in combination with the reverse case.
- E786 REVERSE CASE DIFFERENT PROFILE START POINTS
- E787 IDENTICAL CUT/FILL INTERMEDIATE STRING LABELS NOT ALLOWED  
The same string label must not be used for intermediate strings on elements of both the cut and fill profiles.
- E788 SECTION SET OR 'AUTO' NOT SPECIFIED OR ON INCORRECT RECORD  
The first record in a series of 261's or 262's which is not an 'IGN' record must specify a section set letter or 'AUTO'.
- E789 SECTION STRINGS NOT FOUND  
The specified section set does not exist in the model.
- E790 START AND END SLOPES OF DIFFERENT SIGN  
The gradient of any element of a profile may be varied within the range of application, but the sign of the gradients must not change.
- E791 NO INTERFACE POINTS GENERATED  
The run has failed to find any interface points. No points will be stored on either the intermediate or final interface strings.
- E792 DATUM STRING DOES NOT EXIST  
The string named in field 2 of the first 261 or 262 record does not exist in the model.
- E793 DATUM STRING HAS LESS THAN 2 DIMENSIONS  
The level datum string must contain at least the plan coordinates.
- E794 ALTERNATING 261/262. RECORD IGNORED  
Between a 260 record and is associated 263, all 261 records must be consecutive and all 262 records must be consecutive; ie 261's must not be interleaved with 262's.
- E795 NO CURRENT, VALID 260 MINOR OPTION  
A 261 or a 262 has been input without a valid record.
- E796 MORE THAN 50 261/262 MINOR OPTIONS
-

- E797            LEVEL DATUM STRING DIFFERS BETWEEN  
261 AND 262 PROFILES  
The cut and fill sequences must start from the same level datum string.
- E798            DIMENSIONS INCONSISTENT, STRING  
label. NO STRINGS FILED.  
One of the strings for which points have been calculated already exists in the model with a different number of dimensions from that specified for this run.
- E799            MODEL HAS 'READ ONLY' SECURITY  
The model named on the INTERFACE major option has been set up with read only security – hence the interface strings may not be written to it.

#### **Major option VOLUME**

- E800            ATTEMPT TO FILE MORE THAN 1000  
POINTS IN STRING
- E801            CAN'T FIT CUT/FILL SLOPE TO  
STANDARD SECTION
- E802            STANDARD SECTION NOT OVER  
CROSS-SECTION
- E803            NO 'END' 055 OPTION GIVEN
- E804            TOO MANY POINTS ON STAND-SECTION  
Maximum of 20 points allowed.
- E805            FIRST 055 OPTION HAS NO  
START GIVEN
- E806            MISSING INFO ON 055 OPTION
- E807            055 OPTION OUT OF SEQUENCE
- E808            NO LHS POINT ON SECTION
- E809            NO RHS POINT ON SECTION
- E810            ERROR IN RECW CONTINUATION  
SECTION RECORD
- E811            ERROR IN NUMBER OF AUTO SECTIONS

- E812 NO POINTS IN SECTION IN MODEL 1
- E813 NO POINTS IN SECTION IN MODEL 2
- E814 NO LEVEL IN REFERENCE STRING  
Standard section can not be located.
- E815 SECTION label DOES NO CROSS  
BOUNDARY  
This may occur with the 052 option if the range of sections defined on the reference string is outside the boundary. Also the distance from the reference string to the boundary should not exceed the left and right offset search distance (default set at 100.0 units which may be changed by the 017 option). With the 050 option this error may be produced if an odd number of intersections between the section and the boundary are detected. This will occur if the boundary is not a closed loop.
- E816 STRINGS INTERSECT
- E817 SECTION SET HAS NO POINTS.  
This error is produced from INTERFACE when using a stored section set which has no points.
- E818 NO VOLUMES INFORMATION AVAILABLE.  
VOLUME STRING label NOT CREATED.  
An attempt has been made to create a volume string via minor option 058 when no volumes are available.

### **MISCELLANEOUS**

- E850 CORRUPT DATA, GROUPING INCOMPLETE
- E851 INVALID DATA
- E852 UNABLE TO BEST FIT TRIANGULATION, BETWEEN POINTS  
label AND label ON STRING LABE
- E853 TRIANGULATION NOT CREATED. UNABLE TO FIND  
INTERSECTION WITH SIDE OF TRIANGLE label BETWEEN  
POINTS x coordinate AND y coordinate. TRY REMOVING STRING  
LINK AND RE-TRIANGULATE.
- E854 INSUFFICIENT DISK SPACE TO COMPLETE OPTION  
CREATE SPACE BY DELETING UNNECESSARY FILES AND  
RETRY

**VISUALISE**

- E855            TOO MANY MODELS REFERENCED
- E856            NO STRINGS FOUND
- E857            NO GROUPS FOUND
- E858            OBJECT NOT FOUND

**OSPP ERRORS**

- E860            ERROR ON LINE label - DATAFILE FORMATTED INCORRECTLY
- E861            ERROR ON LINE label - FIELD NOT LEFT JUSTIFIED
- E862            NUMBER OF CODES IN OS1TAB.DAT EXCEEDS MAXIMUM OF  
label

**Major option VIEW**

- E870            NO STATION DATA AVAILABLE  
A point data string has not been processed prior to this option.
- E871            STATION DOES NOT EXIST
- E872            DIRECT ANGLES ONLY ON TARGET  
An attempt has been made to define the eyepoint by angles and this is not possible. The cause of the error will possibly be misplaced data.
- E873            TOO FEW TRANSFORM POINTS  
There is a minimum number of photomontage points needed to calculate the various unknown parameters. If the eyepoint is known and the photomontage is only being used to find the line of sight the minimum of points is two. For full photomontage where both the eyepoint and target are unknown the minimum number of points is four.
- E874            TOO MANY TRANSFORM POINTS  
The program has a limit of twenty (20) transform points.
- E875            INITIAL APPROX. CANNOT BE FOUND  
In photomontage the parameters need to be found using an iterative technique from an initial estimate. If the initial estimate cannot be found this message will ensue. The probable reason will be a gross error in one of the photomontage data points. For full photomontage

this error will also occur if there is not at least one point in each quadrant of the picture, so that a start position for the iteration can be calculated.

**E876 SLOW CONVERGENCE – CHECK DATA  
BEFORE ADDING MORE POINTS**

In trying to find a solution to the photomontage problem, an iterative technique is adopted. If the number of iterations becomes excessive there is a possibility of the solution oscillating about a solution but never actually reaching it. When this happens there will be inconsistencies within the data which when resolved overcome this problem.

**E877 THE RESIDUAL ERROR EXCEEDS number**

If the residual error of a photomontage point is large this error is called. The 'number' is a measure in metres of the displacement between a defined point and its transformed position. If this value is exceeded differences will be very noticeable. An offending data point will often be obvious and its correction or removal will resolve the problem. The 'number' will be five times the point search tolerance as defined on minor option 017. The default value is 0.01, thus making the usual value of 'number' = 0.05.

**E878 PICTURE ORIENTATION NOT DEFINED**

The error will occur if insufficient information is given to resolve the perspective transformation. Usually photomontage is not required and either the eyepoint or target point or both have been omitted.

**E879 NO STRINGS INSIDE VIEWING AREA**

**Major option UPM**

**E892 ERROR IN UPM VARIABLE**

The UPM variable name used in the MOSS line is invalid.

**E893 #FILE NO. IN MOSS DATA ON UPM  
FILE IS INCORRECT**

This occurs if building up a MOSS INPUT file to be used later from within a UPM. This error will occur if the file is locked by another user, the file is not the correct type, or it cannot be accessed due to privileges.

**E894 ERROR OPENING UPM FILE**

**E895 ERROR CLOSING UPM FILE**

- E896            ERROR READING UPM FILE  
                  The file is empty.
- E897            UPM FILE DOES NOT EXIST  
                  Check name or case of name.
- E898            DEPTH MUST NOT EXCEED HALF THE WIDTH
- E899            REVERSE STYLE INTERFACE IS NOT PERMITTED

**Major option MACRO**

- E901            TYPE RECORD OMITTED  
                  When adding a macro, one of the records 'DEFAULT', 'FORMAT' or 'OPTION' has been omitted before the data in the macro.
- E902            TWO TYPE RECORDS IN SUCCESSION  
                  When adding a macro, no data after one of the records DEFAULT, FORMAT or OPTION ie two of these records are in succession.
- E903            EMBEDDED BLANKS IN A RECORD  
                  Blanks found in the data for a macro when adding the macro.
- E904            INCORRECT DATA IN DEFAULT RECORDS  
                  Data after DEFAULT record is not in form NAME = VALUE for example A = 3.0 and each name separated by commas.
- E905            INCORRECT DATA IN FORMAT RECORDS  
                  Data after FORMAT record is not in the form N.T.P. where T is character type A, I, F or C, N is an option integer, P is integer, or for real variable integer or real.
- E906            INCORRECT DATA IN OPTION RECORDS  
                  Variable names in OPTION are too long.
- E907            NO OPTION RECORD IN MACRO  
                  All macros must have at least one OPTION record to be valid.
- E908            INCORRECT USE OF FORMAT RECORD  
                  A FORMAT record must appear before an OPTION record, if not the default FORMAT is assumed. Therefore in a macro there cannot be more FORMAT records than OPTION records.
- E909            NO END RECORD PRESENT  
                  No END record in the macro.

- E910            **MACRO FILE IS FULL**  
When adding a macro, the macro file is found to be full.
- E911            **MACRO NAME ALREADY USED IN LIBRARY**  
A macro already exists in the macro library with the given name.
- E912            **MORE THAN 200 CHARACTERS IN DATA**  
The data after DEFAULT, FORMAT or OPTION records must not exceed 200 characters.
- E921            **MACRO REQUIRED NOT IN LIBRARY**
- E922            **REAL NUMBER OUT OF RANGE**  
When performing real arithmetic, the number specified is too large, or has too many significant figures (more than 14).
- E923            **INTEGER NUMBER OUT OF RANGE**  
When performing integer arithmetic, the resultant number specified is too large or has too many significant figures.
- E924            **RESULT OF ARITHMETIC OUT OF RANGE**  
After the arithmetic operation, the result is too large.
- E925            **FORMAT LENGTH OUT OF RANGE**  
The length of a format field is too large, or has too many significant figures.
- E926            **OUTPUT RECORD EXCEEDS 80 CHARS**  
Output record written to scratch file can only be 80 characters long.
- E927            **REAL VALUE OUT OF RANGE**  
The value of a real variable used in arithmetic operation is too large, or has too many significant figures.
- E928            **INTEGER VALUE OUT OF RANGE**  
The value of an integer variable used in an arithmetic operation is too large, or has too many significant figures.
- E929            **ALPHA-NO ARITHMETIC**  
Arithmetic is not allowed when the format field is type A (alpha numeric).
- E930            **USER INPUT EXCEEDS 200 CHARACTERS**  
The input list when using a macro must not exceed 200 characters.



- E931            USER INPUT ERROR  
The input to the macro is not in the form variable name – value for example A = 4.0 with subsequent fields separated by commas.
- E932            INCORRECT PASSWORD GIVEN
- E933            2 COMMAS REQUIRED FOR X FORMAT  
Where X format appears in the FORMAT data, the corresponding OPTION data must contain two commas in succession indicating the absence of a data term.
- E934            ‘ALL’ INVALID MACRO NAME
- E935            TOO MANY CHARACTERS FOR FORMAT  
Number of characters on input exceeds the length defined in the FORMAT statement.
- E940            VALUE IN FIELD OUT OF RANGE  
When adding drawing macros, the values in fields 5, 6 must be between –99 and +99, and 2, 3, or +1 in field 7.
- E941            FIELD CONTAINS NON–NUMERIC  
In drawing macros, the values in fields 5, 6 and 7 must be numeric.
- E942            FIELD NOT BLANK OR END
- E943            MORE THAN 5000 POINTS ON MACRO  
A macrosymbol or macroline may consist of not more than 5000 constituent points.
- E944            MACRO SYMB/LINE OMITTED
- E945            NO ELEMENT TERMINATOR SUPPLIED
- E946            CONSECUTIVE ELEMENT TERMINATORS
- E947            NO PEN UP AFTER ELEMENT TERMINATOR
- E948            INVALID OPTION
- Plot errors**
- E951            NO INFORMATION IN OPTION 955
- E952            WRONG INFORMATION IN OPTION 955
- E953            TOO MANY MASKS SPECIFIED

- E954 DISCONTINUITY IN BOUNDARY STRING
- E955 BOTTOM LEFT COORDINATES OF PLOT MISSING
- E956 MINIMUM CO-ORDS OF PLOT MISSING
- E957 NO SCALE GIVEN IN 957 OPTION
- E958 NO PLOTTING SCALE HAS BEEN GIVEN
- E959 PLOTFILE FORMAT ERROR
- E960 NOT ENOUGH PLOTS GIVEN ON 955
- E961 AN OVERPLOT CANNOT BE PAGED
- E962 SECTION PLOT GOES OUTSIDE PAGE
- E963 SECTION label NOT CREATED  
FROM REFERENCE STRING OR LINE  
This error occurs when the sections are drawn after the reference string from which they have been created has been edited. If the reference string is edited, it is recommended that the sections be regenerated.
- E964 MAXIMUM NUMBER OF POINTS PER SHEET EXCEEDED FOR SECTION
- E965 UNABLE TO ERECT NORMAL FROM POINT  
coordinates TO REF STRING AT POINT NO number  
Cause of error normally attributed to either duplicate points on a string, or strings in different directions.
- E966 NUMBER OF LINES TO PLOT EXCEEDS 20

### **General Graphics Messages**

- E967 NO EXISTING PICTURE FILE  
No current picture (.dpf) file exists to enable requested graphical option.
- E968 CANNOT INTERSECT ALL ORDINATES  
WITH STRING  
This is a minor option 849 error when some of the ordinates will not intersect with a string which has gone outside the drawing area.
- E969 INVALID WITH CROSS SECTIONS

The selected option cannot use a cross section drawing.

- E970            NO BOTTOM LEFT AVAILABLE  
This error is reported when a picture (.dpf) file has been created with no strings to specify a bottom left for the drawing, and no bottom left has been coded on option 803.
- E971            NOBOTTOM LEFT AVAILABLE
- E972            DISCONTINUITY COINCIDES WITH DEFINED START OF REFERENCE STRING
- E973            NO PRECEEDING OPTION
- E980            JOB TERMINATED BECAUSE OF SYSTEM ERROR  
ABNORMAL END OF JOB
- E981            MODEL FILE IS FULL OR CORRUPT
- E982            MODEL FILE IS FULL
- E984            INCORRECT FILE RECORD ADDRESS
- E985            INCORRECT MACROFILE RECORD ADDRESS
- E986            INVALID INDICATOR TO S/R MACRW
- E987            MACROFILE IS FULL
- E988            THIS SCREEN DOES NOT SUPPORT DOCUMENT
- E989            INVALID GROUP CODE
- E990            THIS SCREEN DOES NOT SUPPORT  
DISPLAY
- E991            THIS SCREEN DOES NOT SUPPORT  
INTERACTIVE MOSS
- E992            END OF FILE READ FROM MENU FILE  
JOB ABORTED  
This error is reported because of a fault in the screen menu file – contact the local MOSS supplier.
- E993            INVALID RECORD – (co–ordinates)  
– READ FROM MENU FILE  
JOB ABORTED  
As 992 but for screen definition file.

- E994            FIRST MENU RECORD WAS NOT 'SCREEN'  
                  JOB ABORTED  
                  As 993.
- E995            SELECTED POINTS ARE COINCIDENT  
                  This is produced by major option ENHANCE minor option 889 – the  
                  two points used in the definition of a circle are coincident.
- E996            SELECTED POINTS ARE TOO FAR APART  
                  This error shows an inconsistency between the 2 points used to  
                  define a circle and the radius.
- E997            NO BLOCK FOUND IN DXF FILE
- E998            NO TRIANGLES IN GROUP CODE
- E999            INVALID MESSAGE REFERENCED

## MOSS warning messages

### General

W001	USE PLOT OR DRAW BEFORE PICT
W002	USE PICT BEFORE THIS OPTION
W003	DISPLAY IGNORED
W004	CANNOT USE BOTH PLOT AND DRAW BEFORE PICT
W010	RASTER IMAGE FILE NOT FOUND Either the image file (.tif) or the supplementary information file (.sup) has not been found.
W011	RASTER IMAGE FILE NOT CORRECT FORMAT The file is not in the TIFF Packbit compression format.
W012	RASTER IMAGE OUTSIDE DRAWING WINDOW Raster image coordinates lie outside the current drawing window.
W013	RASTER IMAGE PROHIBITED WITH ROTATION/PAGING No rotation or paging options are available when using raster images.
W014	RESERVED NAME IGNORED An illegal operation has been attempted on the reserved model name RASTER.
W015	RASTER BACKCLOTH NOT IMPLEMENTED Raster images are not implemented on the platform being used.
W016	COULD NOT ALLOCATE MEMORY FOR RASTER Not enough swap space available to load the raster image.
W017	RASTER IMAGE FILE OPENED
W018	TOO MANY 831 OPTIONS - OPTION IGNORED
W019	NO CALIBRATION INFORMATION GIVEN No .SUP file exists and no data coded on the 831 option or menu.

W022            GEOMETRY OF STRINGS MAY PREVENT COMPLETION OF  
                  OPTIONS

### **Replay Warnings**

W023            MOSS SESSION WILL NOT BE LOGGED.  
                  TO ENABLE LOGGING FACILITIES EXIT MOSS  
                  AND RESET LOG SWITCHES.

W024            ILLEGAL LOGGING SWITCH COMBINATION.  
                  TO ENABLE REPLAY FACILITY EXIT MOSS AND RESET LOG  
                  SWITCHES.

W025            ONLY LINEMODE LOGGING IS ENABLED.  
                  TO ENABLE REPLAY FACILITY EXIT MOSS AND RESET LOG  
                  SWITCHES.

### **General warnings**

W042            THE CURRENT ARCHIVE FILE IS nameW039    STRING HAS  
                  NON-ALPHANUMERIC CHARACTER. STRING IGNORED

W040            NO STRINGS IN MODEL  
                  THIS FILE MAY NOW NEED RE-ASSIGNING

W042            THE CURRENT ARCHIVE FILE IS name

W043            THE CURRENT RETRIEVE FILE IS name

W044            ON FORTRAN UNIT NUMBER nn, label FILE filename

W045            FILE SPECIFIED IS ALREADY OPEN  
                  - FILE NOT label

W046            RENAMING VERSION 8 MODEL NAME

W047            TRIANGLES ALREADY ALLOCATED GROUP CODE

W048            INVALID OPTION WITH TRIANGLE MODEL

W049            KPARAM(1,1) - A4  
                  KPARAM(1,2) - A4  
                  KPARAM(1,3) - A4  
                  KPARAM(1,4)- A4  
                  KPARAM(1,5) - A4  
                  KPARAM(1,6) - A4  
                  KPARAM(1,7) - A4  
                  KPARAM(1,8) - A4

W050	ABOVE MODEL NAMES EXCEED 28 CHARS - RENAME PRIOR TO COMPRESS
W051	STRAIGHT LINE CHAINAGES PRODUCED
W052	STRING HAS NO POINTS - STRING DELETED Some major options are able to preprocess data and remove it if it is redundant.
W053	DIMENSIONS OF TRIANGULATION DATA CANNOT BE REORDERED Cannot use minor option 001 when using GENIO with triangulations.
W054	SOME STRINGS OMITTED FROM VIEW
W055	SECONDARY OFFSET IGNORED
W061	STRING HAS BLANK LABEL
W062	STRING HAS INVALID DIMENSION
W063	STRING HAS INVALID CONTENT FIELD
W064	STRING HAS INVALID NO. OF POINTS
W065	STRING HAS INVALID WORD ADDRESS
W066	2D STRING HAS NO SUBREF TO ANNOTATE
W080	WAITING FOR MASTER CONTROL FILE
W100	WAITING FOR WORLDVIEW.LIS FILE This error will only occur when an attempt to access major option DOCUMENT via a network is unsuccessful due to a network or system problem.
W101	999 OMITTED
W102	INSUFFICIENT DATA
W103	SURPLUS DATA
W104	DEFAULT TOLERANCE: number ASSUMED
W105	DATA FIELD HAS BEEN IGNORED
W106	MODEL NAME IGNORED

W107	OPTION SAVED FOR PROCESSING A 999 record is missing. The major option has been saved and will be processed in due course.
W108	ALIGNMENT NOT STORED
W109	OPTION IGNORED: FILE EMPTY
W110	MORE THAN 9 INTERSECTIONS THE FIRST 10 ARE PRINTED
W111	MINOR OPTION NOT YET AVAILABLE
W112	STRING CANNOT BE FOUND
W113	BOUNDARY HAS LESS THAN 3 POINTS
W114	CORRUPT STRING label DELETED FROM model name
W115	MODEL DOES NOT EXIST
W116	POINTS FOR CURVE FITTING ARE COINCIDENT OR STRAIGHT
W117	POINT COINCIDENT WITH CIRC CENTRE
W118	NO DATA GIVEN – OPTION IGNORED
W119	ANY INFO AFTER COL.80 IGNORED
W120	SYSTEM VALUES HAVE BEEN MODIFIED The message prints values of all the default system parameters.
W121	INVALID MAJOR OPTION – PLEASE RE-ENTER
W122	STRING label IGNORED IN MODEL name  STRING HAS BLANK LABEL or STRING HAS INVALID DIMENSION or STRING HAS INVALID CONTENTS INDICATOR or STRING HAS INVALID NUMBER OF POINTS or STRING HAS INVALID WORD ADDRESS
W123	RADIUS TOO SMALL TO FIND BOUNDARY



- W124            UNABLE TO DECIPHER BOUNDARY
- W125            MAX. MODELS FOR OPTION PROCESSED  
The ARCHIVE, RETRIEVE options will only deal with 125 models.
- W126            OPTION IGNORED  
This model name not processed, see W125.
- W127            MODEL FILE STORED & INITIALISED  
During the COMPRESS option the model file has been written to an intermediate file and the modelfile deleted. If the COMPRESS fails after this message is printed it will be necessary to restore it from backup.
- W128            START POINT NOT AT EXACT POINT
- W129            FINISH POINT NOT AT EXACT POINT
- W130            MODEL name HAS NO STRINGS.  
MODEL ARCHIVE IGNORED
- W131            AUTOMATIC CURVE FITTING INVOKED  
Advises that curve fitting will automatically be invoked for the duration of the current option.
- W132            OPTION SAVED FOR PROCESSING  
Printed after the last record in a REPORT 993 option has been read in.
- W133            INVALID 003 ORDR FOR THIS STRING  
More dimensions have been specified on an 003ORDR record than there are dimensions in the current string; Report option 993 will ignore the string.
- W134            INVALID RECORD TYPE number  
The archive file is only expected to contain the following record types:
- |         |   |                             |
|---------|---|-----------------------------|
| Type 1  | – | model name record           |
| Type 2  | – | string index record         |
| Type 3  | – | data record                 |
| Type 99 | – | end of archive file record. |
- If any other record type is found by the LIST, ARCHIVEFILE, NRECS option, this warning message will be printed. This indicates that the archive file is corrupted – further investigation will be necessary to recover this system error.

- W135**                    **UNEXPECTED ORDER OF RECORD TYPES**  
The archive file should only contain the following sequences of record types:–  
Type 1 (model name record) at start of file  
Type 1 (model name record) followed by Type 2 (string index record)  
Type 2 (string index record) followed by Type 2 ( string index record)  
Type 3 (data record) followed by Type 3 (data record)  
Type 3 (data record) followed by Type 1 (model name record)  
Type 3 (data record) followed by Type 99 (end-of-file record).  
If any other sequence of record types is found by the LIST, ARCHIVEFILE, NRECS option, this warning message will be printed. This indicates that the archive file is corrupted. Further investigation will be necessary to recover from this error.
- W136**                    **2ND INDEX RECORD MISSING**  
Applies to a modelfile listing on a machine having two records per index.
- W137**                    **2ND INDEX RECORD BEYOND LIST SIZE**  
Applies to a modelfile listing having two records per index.
- W138**                    **MODEL HAS ALREADY BEEN SPECIFIED**  
Two 001 records for the same model name have been supplied to an ARCHIVE ERASE RETRIEVE – The second will be ignored.
- W139**                    **DEFAULT CHAINAGE: number ASSUMED**
- W140**                    **INDICATORS INCONSISTENT – VARIABLE**  
'LASTV' = m BUT WORD 502 OF  
RECORD 1 = n  
Printed by Report option 987 while checking file pointers. A possible system error – contact your MOSS supplier.
- W141**                    **INDICATORS INCONSISTENT – VARIABLE**  
'MODSIZE' = m BUT WORD 503 OF  
RECORD 1 = N  
Printed by Report option 987 while checking file pointers. A possible system error – contact your MOSS supplier.
- W142**                    **MODEL INDEX ENTRY FOR MODEL**  
**name**  
**CONTAINS CORRUPT POINTER TO STRING**  
**INDEX – WILL TRY NEXT MODEL**

- Printed by Report option 987 while checking file pointers. If the model is not required delete it; otherwise contact your MOSS supplier.
- W143      STRING INDEX ENTRY FOR STRING label  
            IN MODEL name  
            CONTAINS CORRUPT POINTER TO DATA  
            RECORD – WILL TRY NEXT STRING  
Printed by Report option 987 while checking file pointers. If the string is not required delete it; otherwise contact your MOSS supplier.
- W144      CORRUPT 'NEXT STRING INDEX'  
            POINTER IN MODEL  
            model name  
            – WILL TRY NEXT MODEL  
Printed by Report option 987 while checking file pointers. If the model is not required delete it; otherwise contact your MOSS supplier.
- W145      CORRUPT 'NEXT MODEL INDEX' POINTER  
            – NO FURTHER CHECKING POSSIBLE  
Printed by Report option 987 while checking file pointers. Contact your MOSS supplier.
- W146      NO CURVE FITTING
- W147      CURVE FITTING INVOKED
- W148      THIS OPTION IS NO LONGER SUPPORTED  
            AND IT WILL NOT BE AVAILABLE IN  
            THE NEXT MAJOR RELEASE OF MOSS
- W149      POINT ALREADY EXISTS  
An attempt has been made to insert a point in a string which is coincident with a point already stored, although the level may be different. The string is left unchanged.
- W150      CORRUPT DISCONTINUITY  
A point is flagged in a string as being either a start or end of a discontinuity. The suggested solution is to delete the string between the two points and reinsert a discontinuity.
- W151      STATIONS STRINGS COMBINED  
            CHECK FOR DUPLICATE STATIONS

W152	THIS OPTION IS NO LONGER AVAILABLE The option has been superseded by another option.
W153	**** WARNING – MOSS LICENCE WILL EXPIRE WITHIN number DAYS **** Contact your MOSS supplier to renew your licence.
W154	UNABLE TO OPEN INPUT LOGGING FILE
W155	OPTION ONLY AVAILABLE FROM IGMODE
W156	NO LOGGING IS ENABLED
W157	NO MODELS FIT THE MASK
W158	DISCONTINUITY ADDED TO STRING
W159	VERTICAL/HORIZONTAL GEOMETRY IS INCONSISTENT
W160	AREA BETWEEN SECTION label & label NOT CALCULATED, NO SUB STRING(S)
W161	VALUE OUT OF RANGE, DEFAULT ASSUMED
<b>UPMSEC warnings</b>	
W170	NO UPM NAMES HAVE BEEN SUPPLIED TO UPMSEC
W171	UPM label CANNOT BE OPENED OR SECURED
W172	UPM label IS ALREADY SCRAMBLED
W187	DUPLICATE POINT NAME - DATA IGNORED
W188	INVALID DESCRIPTION CODE - DATA IGNORED
W189	INVALID DESCRIPTION TYPE - DATA IGNORED
W190	INVALID OBSERVATION - DATA IGNORED
W191	MENU MODE TERMINATED. PLEASE ENTER MAJOR OPTION
W192	MENU MODE TERMINATED. PLEASE ENTER MINOR OPTION
W193	CANNOT FIND MAJOR OPTION ON MENU FILE
W194	CANNOT FIND MINOR OPTION ON MENU FILE

W195	MAJOR OPTION MENU MISSING OR DISPLACED ON MENU FILE
W196	HIT ANY KEY TO CONTINUE
W197	INPUT FILE CANNOT BE OPENED The file referenced on the INPUT major option does not exist (check spelling) or is being accessed by another user.
W198	MENU MODE TERMINATED - PLEASE ENTER SUBSYSTEM OPTION
W199	MENU MODE IS NO LONGER AVAILABLE
W200	INVALID SUBSYSTEM OPTION – PLEASE RE-ENTER
W201	END OF INPUT DATA FILE REACHED This warning is reported at the end of reading the batch data input file.
W202	UNEXPECTED MENMOD VALUE number Error in menus – contact your MOSS supplier for further assistance.
W203	INPUT FILE TERMINATED DUE TO ERROR
W204	INPUT FILE SUSPENDED DUE TO ERROR
W205	INPUT FILE RESUMED
W206	NO OUTPUT FILE NAME SUPPLIED
W207	UNABLE TO OPEN OUTPUT FILE

**MSUPMLIC warnings**

W210	WRONG SUFFIX GIVEN - .SGM WILL BE USED. PRESS RETURN TO CONTINUE.
------	--

**Major option EDIT**

W220	CHAINAGE INTERVAL INPUT AS number
W221	APPENDING TO EXISTING STRING label
W222	NULL LEVEL ENCOUNTERED AT POINT number ON SUBSIDIARY STRING label

- W223            SUBSIDIARY STRINGS ARE TOO CLOSE AT  
co-ordinates
- W224            SLOPE CHANGES IN SIGN NEAR  
POINT co-ordinates
- W225            LIMIT OF 20000 POINTS ON SLOPE  
SIGNATURE OF STRING IN ONE RUN –  
ADDITIONAL POINTS IGNORED.
- W226            INSUFFICIENT LEVEL INFORMATION.  
CHECK NULL LEVELS IN STRING label
- W227            DISCONTINUITIES ENCOUNTERED AND IGNORED  
While creating a string, a discontinuity in the reference string was  
found. This is interpreted as a string link in the new string.
- W228            INPUT AND OUTPUT CONVENTIONS MUST MATCH
- W229            STRING SUBREFERENCE DIFFER
- W230            USE OPTION 33 TO CHANGE SUB-REFERENCE - OPTION  
IGNORED
- W231            CADASTRE STRING MASK CHANGE IGNORED
- W232            CADASTRE STRING SUB-REFERENCE CHANGE IGNORED
- W233            CADASTRE STRING - OPTION IGNORED
- W234            SINGLE POINT INDICATOR SET IGNORED
- Major option DESIGN**
- W250            RADIUS FOUND AT CHAINAGE number  
IS LESS THAN OFFSET
- W251            HAND OF ARCS ARE INCONSISTENT  
HAND OF ARC 2 WILL BE TAKEN
- W252            HORIZONTAL STEP EXCEEDS TOLERANCE  
When a string is being amended or extended by a horizontal design  
option the end points of the application should tie into the existing  
part of the string. If there is in fact a step created in the string this  
warning is given. It should be noted that longitudinally the string  
must be continuous, and it is only normal to the reference string that  
a step might exist. This is illustrated in the following diagram.

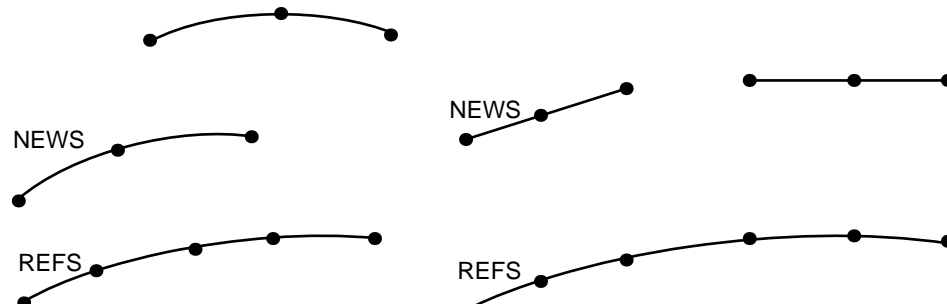


Figure A - 9 Example of W252

- W253 CHAINAGE INTERVAL REDUCED DUE TO TOLERANCE  
The tolerance ensures that the straight line fit between two consecutive points approximates the curve. The chainage interval sometimes needs reducing for small radius curves to avoid this tolerance being contravened.
- W254 LEVEL DATUM TAKEN AS number
- W255 CROSSFALL CALCULATED FROM number/RADIUS  
The crossfall has been calculated based on a theoretical formula where the constant number has been used. (Minor Option 133).
- W256 DIFFERENT LABELS ENCOUNTERED  
– END OF OPTION 099  
The fast design option 099 will only remain active whilst the subsequent design options operate on the same strings as defined on the option 099.
- W257 POINTS OUT OF RANGE  
– END OF OPTION 099  
The fast design option 099 will only remain active whilst the subsequent design options operate within the range of the reference string defined defined on the option 099.
- W258 OPTION OUT OF RANGE  
– END OF OPTION 099  
Most but not all Design options may operate within the Fast Design option. Only options within the range 100 – 139 can apply.
- W280 DESIGN SPEED BELOW ARP STANDARDS, FOR RELIEF DIFFICULTIES ONLY

W281	DESIGN SPEED ABOVE ARP STANDARDS
W282	ARP -TYPE T Indicates the current road type using French design rules
W283	ARP - TYPE R & T Indicates the current road type using French design rules
W284	ARP - TYPE R Indicates the current road type using French design rules

**Major option DRAW**

W300	NO PREVIOUS PLOT TO OVERPLOT Although an overplot has been requested the initial drawing has not been defined or created.
W301	MOSS RECORD WILL NOT RESET ERROR CONDITION FOR OVERPLOT Generally the use of a MOSS record will reset values so that more options may be run. However, in certain instances in Major option DRAW the MOSS record will not have this effect.
W302	STRING OUTSIDE PLOTTING AREA The string that has been requested does not lie within the drawing area and therefore will not be drawn.
W303	NO STRINGS IN PLOTTING AREA The string which has been requested does not lie within the drawing area and therefore will not be drawn.
W304	ONLY ONE 001 OPTION ALLOWED. SUBSEQUENT 001 OPTIONS IGNORED Subsequent 001 options ignored.
W305	SPECIFIED DIMENSION DOES NOT MATCH STRING DIMENSION. STRING IGNORED The fourth dimension of the three dimension string or similar occurrence has been requested.
W306	POINT NOT FOUND ON STRING. STRING IGNORED The point which has been requested cannot be found.



- W307            TOO MANY GENERATED LABELS.  
                  ALLOCATED LABEL NOT UNIQUE  
                  Allocated label not unique.
- W308            NEW PEN TYPE     – NOT STORED  
                  EXCEEDS MAXIMUM ALLOWED
- W309            CURRENT LINE TYPE IS MACROLINE.  
                  OPTION WILL USE PLAIN LINE
- W310            NEW CHARACTER TYPE – NOT STORED  
                  EXCEEDS MAXIMUM ALLOWED  
                  Maximum number of character types allowed is 99.
- W311            NEW CURVE FIT TYPE – NOT STORED  
                  EXCEEDS MAXIMUM ALLOWED  
                  Maximum number of curve fit types allowed is 99.
- W312            SHEET LENGTH number EXCEEDS MAX  
                  ALLOWED. NOW SET TO number  
                  The installations maximum length allowed for a plot has been  
                  exceeded. The page size has been reset for the remainder of this  
                  drawing.
- W313            SHEET WIDTH number EXCEEDS MAX  
                  ALLOWED. NOW SET TO number  
                  The installations maximum width allowed for a plot has been  
                  exceeded. The sheet size has been reset for the remainder of this  
                  drawing.
- W314            BOTTOM LEFT NOT SPECIFIED FOR NEW  
                  MARGINS – NOW SET TO OVERALL BL  
                  Although new margins have been defined a new bottom left relative  
                  point has not been defined on an option 803.
- W315            SHEET LENGTH IGNORED –  
                  INFINITE SHEET  
                  Both an infinite sheet and a sheet length have been defined on  
                  option 800. The infinite sheet is assumed.
- W316            SHEET WIDTH IGNORED.INFINITE SHEET  
                  Both a sheet width and an infinite sheet have been defined on  
                  option 800. The infinite sheet is assumed.
- W317            OPTION UNAVAILABLE WITH SECTIONS

- W319 CHARACTER TYPE NOT ALREADY DEFINED
- W320 CHARACTER TYPE ALREADY DEFINED  
A character style of this name has already been set up.
- W321 REQUESTED PLOT LENGTH EXCEEDS  
REMAINING SPACE  
Insufficient drawing area remains for the required string to be drawn.  
For example, Length of long section, including boxes is greater than  
length defined in option 804, field 4.
- W322 STRING HAS NO POINTS  
The string requested to be drawn has no points and consequently  
cannot be drawn.
- W323 OPTION IGNORED - 880,ALL IN USE
- W324 880,ALL - OPTION WILL OVERRIDE ANY PREVIOUS 880  
OPTION
- W327 DUPLICATE NODE STORED FOR number  
LABEL label
- W328 STRING label HAS ONLY ONE POINT  
– STRING IGNORED  
Minor option 825 is being used to draw a single point string other  
than a station string with detail interpretation.
- W329 INCONSISTENT USE OF 803 OPTION  
Page rotation coded but no bottom left coordinate given on minor  
option 803.
- W330 AREA OF INTEREST TRUNCATED  
TO FIT WINDOW  
The total area of the model under consideration has been reduced  
to that which will fit in the current window.
- W331 NO 825/826/827/828/831 OPTION CODED  
Omission of any of these options means, effectively, there are no  
strings to be drawn.
- W332 OPTION NOT YET IMPLEMENTED
- W333 MODEL UNITS NOT YET IMPLEMENTED

- W334            CONTOUR ANNOTATION NOT  
                 YET IMPLEMENTED
- W335            PLAIN LINE WILL BE USED  
                 An invalid MACROLINE type has been entered causing DRAW to  
                 revert to the default type of a solid line.
- W336            NO GRID SPECIFIED – OPTION IGNORED
- W337            NO INTERVAL GIVEN – OPTION IGNORED  
                 This is reported when minor option 822 is used to draw a grid and  
                 neither field 5 nor field 6 is coded to specify the grid intervals.
- W338            NO HORIZONTAL GRID WILL BE DRAWN  
                 This is reported on using minor option 822 when field 6 is not coded  
                 but field 5 is.
- W339            NO VERTICAL GRID WILL BE DRAWN  
                 This is reported on using minor option 822 when field 5 is not coded  
                 but field 6 is.
- W340            INVALID TYPE – FULL ASSUMED  
                 The label in field 1 is neither a macro name nor one of the allowable  
                 grid styles: NOGR FULL CROS EDGE
- W341            INVALID OPTION FOR OVERPLOT  
                 An attempt has been made to use a 800, 802, 803 or 804 minor  
                 option following a 801, OVER minor option. These minor options  
                 which specify the basic layout of a drawing must not be used  
                 between the initial DRAW and an overplot.
- W342            OVERWRITING PREVIOUS DRAW OPTION  
                 A picture file exists and a new picture file is to be written over it.
- W343            CANNOT ACCESS INPUT AT THIS LEVEL  
                 INPUT cannot be accessed from certain areas. Mostly the cause of  
                 this warning will be obvious but if not contact your MOSS supplier.
- W344            INVALID OPTION – USE ENHANCE  
                 An attempt has been made to use ENHANCE from within DRAW –  
                 the ENHANCE major option itself should be used.
- W345            NEW LINE TYPE – NOT STORED  
                 EXCEEDS MAXIMUM ALLOWED  
                 Maximum number of line types is 99.

- W346            DEFAULT LABEL USED – label  
This is reported whenever the 808 minor option assigns a default to a character type.
- W347            MORE THAN 500 MODEL NAMES USED  
There is a limit of 500 model names for IGMODE.
- W348            MAXIMUM NUMBER OF PICTURE  
ELEMENTS EXCEEDED  
A picture has been drawn where the maximum number of elements (lines, circles etc) is greater than 10000. This can be worked around by creating a single segment object with 814,sing,,xxxx.

### **Major option HALGN**

- W350            THIS ALIGNMENT OVERWRITES  
AN EXISTING ALIGNMENT
- W351            RECORD IGNORED BECAUSE OF  
DIAGNOSTICS ENCOUNTERED
- W352            label FIELD NOT APPLICABLE  
For example a radius has been given as part of the element definition for a straight.
- W353            label NOT ENTERED  
label CHANGED TO label  
If point P1 has not been specified but P2 has been then P2 will be taken as being P1. Similarly if P2 has not been specified but P3 has.
- W354            ELEMENT label CHANGED TO label
- W355            TRANSITIONS CANNOT APPLY  
TO STRAIGHTS
- W356            INVALID FIELD DESCRIPTOR label
- W357            TRANSITIONS ON ELEMENT label  
ADJUSTED TO RLMIN
- W358            RL VALUE FOR TRANSITIONS BETWEEN  
number AND number AMENDED TO number SMALLER  
The transition joining two curves of the same hand has a common RL value and different RL values have been specified or an incorrect RL value has been specified between two fixed elements for which there is a unique mathematical solution.

- W359 UNRESOLVED TRANSITIONS BETWEEN  
ELEMENTS label AND label
- W360 TRANSITIONS FOR ELEMENT label  
HAS RL VALUE number  
– BELOW MINIMUM
- W361 TRANSITIONS FOR ELEMENT label  
TOO LONG – ZERO LENGTH ADOPTED
- W362 TRANSITIONS FOR ELEMENT label  
NOT USED – ZERO LENGTH ADOPTED  
The transition is defined in relation to the radius but the radius is  
itself one of the unknowns.
- W363 ELEMENTS label label TOUCH  
APPROPRIATE TRANSITIONS REMOVED
- W364 RL VALUE FOR TRANSITIONS BETWEEN  
number AND number AMENDED TO number
- W365 ADD number TO ALL EASTINGS AND  
ADD number TO ALL NORTHINGS  
The size of the coordinates are so large that they cannot be  
accommodated in their original form in the output. A local  
coordinate system has been used.
- W365 (DANISH VERSION)  
ADD number TO ALL NORTHINGS  
ADD number TO ALL WESTINGS
- W366 ELEMENTS label AND label  
ARE ADJACENT STRAIGHTS  
Consecutive elements whilst being defined with a common point are  
not tangential and a break in the bearing continuity is indicated.
- W367 FIRST POINT RECALCULATED  
ALIGNMENT STARTS BEFORE  
FIRST DEFINED POINT  
The first point defined for the option does not actually lie on the  
alignment and to allow continued processing its parameters have  
been changed.
- W368 THIS ALIGNMENT NOT STORED  
Only the curve analysis has been output and no string information  
has been stored.
-

W369 POINTS number AND number ON GEOMETRY STRING ARE COINCIDENT

**Major option HALGN - French warnings**

W371 NO CLOTHOID REQUIRED FOR ELEMENT NUMBER number.  
RADI ABOVE LIMIT.

W371 NO CLOTHOID REQUIRED FOR ELEMENT  
NUMBER number.

W372 INVALID ROAD TYPE,  
DEFAULT (AR) ASSUMED.

W373 INVALID DESIGN SPEED,  
DEFAULT (120KPH) ASSUMED.

W374 INVALID MINIMUM CROSSFALL,  
DEFAULT (2.5%) ASSUMED

W375 INVALID NUMBER OF LANES,  
DEFAULT (2) ASSUMED.

W376 TR-RN AND NL=4 CODED. THEREFORE  
AUTO-ROUTE CLOTHOID RULES APPLY.

W377 TRANSITION TYPE INVALID FOR CS  
ELEMENT. MUST USE L6 AND T6.

W378 RULES FOR DESIGN SPEED v KPH APPLIED  
RADIUS r  
IPARAM(1,1) - I3  
RPARAM(1,1) - F5.1

W379 RADIUS < r, NO RULES APPLIED  
IPARAM(1,1) - I3

W380 CLOTHOID LENGTH I APPLIED TO RADIUS < r  
RPARAM(1,1) - F5.1  
RPARAM(1,2) - F5.1

W381 CLOTHOID TRANSITIONS CREATED BETWEEN ELEMENTS  $e_1$   
AND  $e_2$

W381 TRANSITIONS CREATED BETWEEN ELEMENTS  $e_1$  AND  $e_2$

W382 EXISTING GEOMETRY STRING IS BEING OVERWRITTEN

- W383 CHAINAGE DATUM SUPERSEDES CF VALUE
- W384 CHAINAGE OF ELEMENT RESTRICTED TO FULL CIRCLE

**Major option HCUSP**

- W385 STRAIGHT LINE TOLERANCE EXCEEDS  
RECOMMENDED MAX.=0.1 (0.5 IMP) CHORD-TO-ARC  
TOLERANCE EXCEEDS RECOMMENDED MAXIMUM OF 0.1 (0.5  
IMP)  
The tolerance that ensures the straight line fit between two  
consecutive points is sufficiently accurate has been set to 0.1. This  
occurs when the tolerance is left blank or is specified as less than  
0.0001.
- W386 SPECIAL CH. NOT DEFINED IN RANGE  
The special chainage does not lie between the start and finish  
chainage and is ignored.
- W387 FINISH CH. LT OR EQ START CH.  
This will occur if the finish chainage is left blank. The alignment  
details are calculated up to the last location point.
- W388 CH. OF FIRST POINT GT START CH.  
The start chainage is made equal to the chainage of the first point  
and alignment details are calculated from that point.
- W389 RADIUS BELOW SPECIFIED MINIMUM
- W390 CLOTHOID ORIGIN ASSUMED AT POINT coordinate
- W391 ADJACENT STRAIGHT ELEMENTS  
- G STRING NOT CREATED
- W392 TRANSITIONS FOR ELEMENT number  
TOO LONG
- W393 UNABLE TO CALCULATE RL VALUE  
BECAUSE OF ZERO RADIUS
- W400 SPECIFY A PREVIOUSLY DEFINED TYPE  
OR TYPE LAST USED WILL DEFAULT
- W401 876 OPTION MUST FOLLOW 875 OPTION

W402	DISCONTINUITY FOUND AT START OF CHANNEL, SOME CROSSFALL WEDGES MAY BE MISSING
W403	FEATURE CODE TABLE NOT FOUND
W404	FEATURE CODE/MASK NOT IN TABLE
W405	CADASTRE STRING NOT IN MODEL
W406	INVALID STRING TYPE FOR OPTION
W407	CADASTRE FILE NOT FOUND
W408	VERTICAL SCALE ANNOTATION IGNORED
W409	MULTIPLYING NON A OR B SHEET SIZE
W410	SHEET SIZE MODIFIED TO size
W411	DATA MISSING ON CADSYMBL.DAT. DEFAULT USED
W412	MACROSYMBOL NOT FOUND * SUBSTITUTED
W413	SHEET ORIENTATION IGNORED
W414	ANNOTATION OF SCALE IGNORED

**Major option VCUSP**

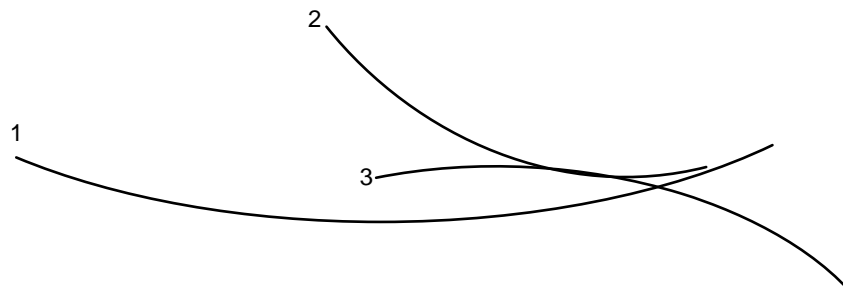
W430	START CH. AFTER START OF ALIGNMENT
W431	FINISH CH. BEFORE END OF ALIGNMENT
W432	VERTICAL STEP EXCEEDS TOLERANCE OLD LEVEL = number The difference between the new and old level at the start/finish point is greater than the tolerance. Possible data error.
W433	OLD VERSION OF DATA ACCEPTED A gradient greater than, or equal to, 999999, has been accepted as meaning the following element is a straight.

**Major option VALGN / VERAT**

W450	TANGENT POINT
W451	END CHAINAGE



- W452            RATE OF CHANGE OF GRADE GT LIMITS
- W453            CANNOT DECIDE SOLUTION FOR CURVE  
ELMT number – HAVE ACCEPTED SHORTEST  
In fitting a floating or a free curve number the two possible solutions are both feasible; the curve which has the shortest length has been preferred.
- W454            CRVE number OVERLAPPED PREVIOUS CRVE  
The tangent point of curve XX with the curve following it lies before the tangent point of the curve II with the curve before it.



**Figure A - 10    Example of W454**

- W455            CHAINAGE SPECIFIED ON CRV number  
IS OUTSIDE THE TANGENT POINTS  
Although the alignment has been fully resolved the points defining the element do not lie within the tangent points of the curve with the adjacent elements.
- W456            MAXIMUM CURVE LENGTH CONTRAVENED  
The curve length of the element is less than that defined in the initial data.
- W457            MAXIMUM SAG VALUE EXCEEDED
- W458            MAXIMUM HOG VALUE EXCEEDED
- W459            MAXIMUM PERCENT GRADE EXCEEDED  
The absolute percentage grade is greater than the maximum – as defined in the initial data.
- W460            ELEMENT number HAS TOO MUCH FIXITY  
The curve is defined as fixed but one of the adjacent curves is also fixed which means that tangency conditions may not be resolved.

The same warning occurs for floating elements when the floating curve can be floated into either the curve before it or the curve after it. If tangency conditions with the adjacent curves are not achieved error 462 will result.

W470 SPECIFIED LENGTH OF TRANSITION BETWEEN ELEMENTS  
label AND label IGNORED

W471 PLAN DISTANCE CALCULATED

### **Major option DRAW**

W500 PREVIOUS OBJECT CLOSED  
An 814 minor option has been used without the previous object being closed by an 815. The program closes the previous object.

W501 NO CURRENT OBJECT  
An 815 minor option has been used to close an object when no object has been previously specified on an 814.

W502 OPTION number IGNORED – ELEMENT  
number INVALID OR NON-EXISTENT

W503 OPTION number IGNORED – OBJECT  
number INVALID OR NON-EXISTENT  
The above 2 warnings are produced by minor options 892 and 893 – the offending option being reported in the message. The element referenced is invalid (ie not an enhance element) or does not exist so it cannot be underlined (minor option 892) or replaced (893).

W504 MESH ARRAY EXCEEDED – MESH IGNORED  
Maximum allowed is 49.

W505 INVALID STRING TYPE – STRING IGNORED  
If this warning occurs while using major option 3DDXF it is likely that a 4 dimensional survey string has been encountered.

W506 NUMBER OF ROWS/COLUMNS SET TO 1  
FOR AUTO CROSS-SECTIONS  
This feature allows a single cross section to be fitted to a known sheet size. The number of rows and columns should be set to 1.

### **Major option DIGIT**

W551 DUPLICATE POINT USED-POINT DELETED

Within the transformation calculation the points which provide the information must be distinct. Should two points be identical one is ignored and the least squares transformation calculation is carried out on the remainder of the points.

- W552                    ~~—————STRING DELETED—————~~
- The input data to the program has generated a string but midway through it a terminator instruction (-999) has been given which cancels it.
- W553                    POINT NOT IN BLOCK BOUNDARY
- Any point not lying within the area defined as the block boundary is ignored. This also applies to points on a string which passes out of the boundary and then returns into the block area.
- W554                    STRING RELABELLED FROM AAAA
- A string called AAAA already exists within the model. The label which the string has been given is defined immediately before this warning.
- W555                    THE RESIDUAL ERROR IS LARGE
- The absolute magnitude of the errors in the least squares transformation calculation is compared to the value defined in the initial data. Where the error is greater than half that defined (default value 1.0) this warning is given. Close examination of the transformation point may reveal an error or it may simply be a reflection on the data collection.
- W556                    FOLLOWING TRANSPOSITION POINT  
HAS TWICE THE STANDARD ERROR  
TABLE X1X1 Y1Y1  
TRUE X2X2 Y2Y2  
TRANS X3X3 Y3Y3
- The least squares transformation has been carried out between the two sets of coordinate system (table and true) and the mentioned point has transformed coordinates greatly different from those expected. One or other of the coordinates will very probably be in error. If the point is in error it ought to be either corrected or deleted and the transformation re-calculated, together with the string information within that block, since the incorrect data point has been used in the transformation calculation.
- W557                    BLOCK CO-ORDS HAVE BEEN  
SORTED INTO ORDER

- W558            THIS POINT HAS BEEN IGNORED
- W559            UNEXPECTED END OF DIGIT DATA  
DATA STORED
- Major option SURVEY**
- W570            OBSERVATION NOT STORED  
An IGN indicator has been recognised.
- W571            APP INDICATOR IGNORED
- W572            NOTHING STORED  
NUMBER OF RECORDS IN ERROR = number  
No observation points will be stored. The errors should be corrected and the whole Major option re-run.
- W573            DISCREPANCY IN CHECK OBSERVATION
- W574            CHECK LABEL IS CORRECT  
A string label in the form XbXb has been recognised and processed. Check that label should not be XXbb or XbbX.
- W575            COLLIMATION LEVEL IS NULL  
All observed points from this instrument Set Up will be stored with null levels.
- W576            ORDER OF STADIA READING CHANGED  
The information will be accepted by the Major Option.
- W577            INSTRUMENT SET UP RECORD OMITTED  
After an Instrument Constant record an Instrument Set Up record is required only when Instrument is moved to another station.
- W578            STATION label CHANGED FROM :  
co-ordinates  
number  
The new station replaces an existing station. It is important to check that the old station co-ordinates are no longer required.
- W579            COLLIMATION LEVEL CALCULATED  
FROM THE REFERENCE STATION
- W580            SEQUENTIAL STRING NO. number  
This warning is output to assist the user to trace the strings as labelled in the model back to their origin.

- W581            STATION NOT FOUND
- W582            ZERO TARGET HEIGHT ASSUMED  
The height of collimation has been set on the 200 option but no target height has been given on the first observation record.
- W583            ZERO INSTRUMENT HEIGHT ASSUMED  
A target height has been given on an observation record but no collimation details have been given on the 200 option.
- W584            STATION GIVEN NULL LEVEL  
Coordinates have been calculated but it was not possible to calculate a level for the station – probably because the reference stations have null levels.
- W585            LEVEL CALCULATED FROM LESS THAN 3 OBSERVATIONS  
The user should carefully check the printed output for the calculation of the station and ensure that an acceptable level has been assigned.
- W586            CHORD TO ARC TOLERANCE OUT OF RANGE  
DEFAULT XX ASSUMED
- W587            CANNOT CURVE FIT – 201 ASSUMED  
The user has not specified enough 202 options to allow a curve to be generated – straight elements are generated.
- W588            TOO FEW RECORDS FOR MOSS CURVE.  
ATTEMPT TO USE SPLINE CURVE
- W589            INSUFFICIENT POINTS FOR SQUARING.  
A minimum of 3 points is needed. The observations will be stored with no adjustments.
- W590            MORE THAN number POINTS ON STRING  
TO BE SQUARED.  
A maximum of 20 points is allowed. The observations will be stored but no squaring adjustments will be made.
- W591            CANNOT SQUARE CURVE FITTED STRING.  
202 options and the SQUR/SQUC indicators have been coded for a string.
- W592            CANNOT SQUARE DISCONTINUOUS STRING.

SQUR/SQUC and DISC have been coded for a string.

- W593            CANNOT SQUARE STRING CONTAINING  
                 COINCIDENT POINTS.  
                 The program has found identical points in the string to be squared  
                 (other than the first and last points). There is probably an error in  
                 booking the data.
- W594            OBSERVED CO-ORDINATES STORED.  
                 This message will appear with one of the previous five messages. It  
                 confirms that the unadjusted observations have been stored when it  
                 has not been able to square the string.
- W595            ORIGINAL SETUP DETAILS OVERWRITTEN.  
                 For a traverse or resection calculation the reference station and the  
                 horizontal angle datum should not be given on the 200 option. The  
                 values are taken off observation records by the program. If values  
                 are given on the 200 record they are not used.
- W596            OBSERVATION REJECTED.  
                 ERROR IS TOO LARGE.  
                 The error for this observation is significantly larger than the errors  
                 for other observations in the analysis. The observation is eliminated  
                 and the solution recalculated with the remaining observations.
- W597            INSTRUMENT TOLERANCE OUT OF RANGE.  
                 DEFAULT OF number ASSUMED.
- W598            YOU HAVE OVERRIDDEN THE ABSOLUTE  
                 ANGULAR/DISTANCE/LEVEL ERROR CHECK.  
                 THIS SOLUTION WOULD NOT BE ACCEPTED  
                 OTHERWISE.  
                 Option 190, NRCH has been used to force the program past the  
                 absolute check on the size of an error. The user should check the  
                 accuracy of the observations for this calculation.
- W599            CANNOT CHANGE CURVE FITTING STYLE  
                 WITHIN A CURVE. INDICATOR IGNORED.  
                 MOSS and SPLI indicators have both been coded for a single curve.
- W600            RADIUS OF EARTH INPUT AS number
- W601            REFRACTION COEFFICIENT SPECIFIED  
                 AS number

W602	CURVATURE/REFRACTION CORRECTION INVOKED.
W603	HEIGHT ABOVE SEA LEVEL INPUT AS number
W604	SCALE FACTOR INPUT AS number
W605	MOSS CURVE FITTING APPLIED.
W606	SPLINE CURVE FITTING APPLIED.
W607	UNSUITABLE POINTS FOR SQUARING
W608	ANGULAR/DISTANCE ADJUSTMENT FOR label OBSERVATION IS LARGE.
W609	INDICATOR IGNORED. STRING label IS NOT IN THE MODEL.
W610	POINT GIVEN NULL LEVEL

### **Major option SECTION**

W624	SECTION REDUCED TO ALLOW FOR BOXES
W625	MORE THAN 999 PRIMARY CUTS – ONLY FIRST 999 ACCEPTED For a single section created by options 170, 172, 173 or 174 there is a maximum limit of 999 primary points.
W626	START AND FINISH POINTS EXCHANGED TO MAINTAIN INCREASING CHAINAGE The system does not allow decreasing chainages for this option.
W627	FURTHEST TARGET POINT REACHED.

### **Major option SETOUT**

W675	SECOND REF. STATION NOT STORED In minor option 181 which set out by deflection angles a final check angle may be requested. In this instance the station is defined but does not exist, and the calculation proceeds omitting this final check.
W676	NO INST. INTERVAL SPECIFIED

Minor option 181 which sets out by deflection angles, allows and expects a distance interval for moving the station. If it is not defined the deflection angles will be based on the first point. A nominal value of 1 million is set for the instrument interval.

W677 STATIONS STRING HAS BEEN CREATED

W678 STATION label REPLACED  
IN STATIONS STRING

W679 STATION label DELETED  
FROM STATIONS STRING

W680 STATION label ADDED  
TO STATIONS STRING

The above four messages are informative rather than warnings and cause no errors.

W681 BLANK STATION FIELD

Minor option 180 manipulates a station point, either storing it for present use or modifying the station string. The warning is given when an option 180 is requested but the station label is not defined. The effect is that this particular minor option is ignored. The most common cause of this warning is when the station name has been defined in field 1 rather than field 3 of the minor options.

### **Major option HAUL**

W702 SPECIFIED EXPORT VOLUME EXCEEDS  
VOLUME AVAILABLE AT CHAINAGE number

W730 START POINT NOT SPECIFIED.  
FIRST POINT ON label ASSUMED.

The SPRD has not been explicitly defined so an indication of exactly which point is being referenced is given.

W731 END POINT NOT SPECIFIED.  
LAST POINT ON label ASSUMED.

The SPRD has not been explicitly defined so an indication of exactly which point is being referenced is given.

W732 MASS STRING 'label' NOT CREATED

Owing to errors encountered the mass string has not been generated.



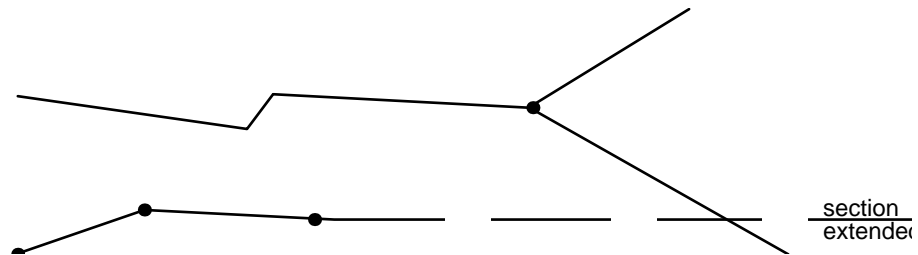
- W733            BULKING/SHRINKAGE FACTOR SPECIFIED  
AS number  
The factor input is echoed to confirm its value whenever the value is outside the range (0.4, 1.6).
- W734            EXPORT POINT NOT AN EXACT POINT
- W735            IMPORT POINT NOT AN EXACT POINT  
The quantities may only be assigned at exact points. The point at the beginning of the string link is used.
- W736            STRING 'label' DELETED  
Owing to errors encountered this string has been deleted.
- W737            SURPLUS DATA – OVERALL BULKING/  
SHRINKAGE FACTOR APPLIES TO  
MATERIAL TYPE 1  
When specifying import of material 1 no bulking / shrinkage factor is needed as that specified in the 072 record is used.
- W738            FINAL OPTION 071 OMITTED
- W739            MINOR OPTION 074 OMITTED  
Minor options 071 and 074 without any data fields completed, indicate to the option that the current set of data may be analysed. Failure to include a 'blank' option 071 or 074 results in the first record of the next 'set' of data invoking the analysis and consequently being misplaced in the printed output.
- W740            POINT SPECIFIED IS OUTSIDE RANGE  
OF MASS STRING. FIRST POINT ON  
label IS ASSUMED.
- W741            POINT SPECIFIED IS OUTSIDE RANGE  
OF MASS STRING. LAST POINT ON  
label IS ASSUMED.  
Although the point exists on the reference string the mass string does not extend over the full extent of the reference string. The first / last point of the mass string is assumed.

### **Major option INTERFACE**

- W751            SECTION STRING label NOT FOUND

When a section set letter is specified, the program searches for a section, with this initial character, associated with each point on the reference string. One of these sections does not exist.

- W752      ASSOCIATED DATUM STRING PT FOR PT.  
 number ON REF. STRING DOES NOT EXIST  
 The normal from the reference string at this point has not cut the level datum string. Check the relative geometry of the two strings.
- W753      SECTION EXTENDED HORIZONTALLY (250 interface only)  
 If the ground section is not intersected by the interface profile the section is extended to produce an intersection. The warning is given in case the assumption that from the last point on the section the ground is flat, is untrue. The situation is illustrated in Figure A - 11



**Figure A - 11    Example of W753**

- W754      SECTION label HAS NO POINTS  
 Although an attempt has been made to find a section the ground information is so sparse that no cuts can be found on the section. The result is that even though the section string exists there are no points on it, and the Interface is assumed to go from the section before to the section following.
- W755      PROFILES TOO SHORT AT SECTN label  
 Even by extending the ground section horizontally it has not been possible to detect the interface point. The Interface profile is itself 1000 metres wide so the probable cause is that the interface slope is small and the ground section runs nearly parallel to it. No interface point will be generated and the interface will be assumed to go from the point before to the point after.
- W756      SECTION label HAS ONLY ONE POINT.  
 NO INTERFACE PRODUCED AT THIS SECTION

If there are two or more points on a section, the section may be extended by the program in order to calculate the interface. A one point section will not be extended.

- W757            NULL LEVEL AT SECTION label  
Where a null level is encountered in the level datum string it is impossible to position the interface profile. The result is that no interface point exists for this section and the interface is assumed to go from the point before to the point after.
- W758            COINCIDENT POINT IGNORED ON label AT  
COORDINATES co-ordinates
- W760            NO INTERFACE STRING
- W761            261/262 RECORD IGNORED.  
UNCONNECTED SLOPE SPECIFIED  
As the elements of a profile are being checked for an intersection with the ground section, an element has been found from which there is no path back to the level datum string.
- W762            NO INTERFACE  
FOUND FOR SECTION label  
No string points will be generated at this section for either the final or the intermediate interface strings.
- W763            ASSOCIATED DATUM STRING PT FOR PT.  
number ON REF. STRING HAS NULL LEVEL
- W764            NO INTERFACE FOUND INTO SECTION  
SET number AT SECTION label.  
This is produced only when multi-strata interfaces are being generated. An interface has been found into at least one stratum, and all the profiles into the next stratum have been processed without finding an interface. Any further elements into higher strata are processed using the most recent interface found as their start point. The probable cause of this situation is that the section does not exist or that widths have been specified for all the elements in the stratum.
- W766            STRING label HAS HAD number  
EXTRA POINTS GENERATED  
The program has added interpolation points to the string. See Chapter 6 for an explanation of how these points are generated.

- W767           INVALID STRING DIMENSION.  
                DEFAULT 5-D ASSUMED  
                An invalid dimension has been entered in field 4 of a 261 or 262  
                minor option. The entry should be 3 or 5.
- W768           FILING STRING label WHICH ALREADY CONTAINS POINTS  
                This is reported whenever extra points are added by INTERFACE to  
                a string which already contains points.
- W769           RECORD IGNORED. THE ELEMENT AFTER  
                A REPEAT MUST BE TO A NEW STRATUM
- W770           STRING label HAS HAD DISCONTINUITY GENERATED
- W788           SPECIFIED LEVEL IGNORED, PLAN DISTANCE CALCULATED
- W789           NON MASTER STRING, INDICATOR IGNORED
- W790           THERE ARE NO LEVEL POINTS
- W791           ATTEMPT TO APPEND TO NEW FILE
- W792           SLOPE EXCEEDS 50% BETWEEN POINTS coordinates
- W793           STRING DOES NOT CONTAIN LEVELS
- W795           EQUIVALENT GEOMETRY STRING NOT FOUND
- W796           NOT ALL REQUESTED INFORMATION AVAILABLE  
                FOR STRING label
- W797           NO LEVEL PROVIDED THEREFORE PLAN DISTANCE WILL BE  
                CALCULATEDGIVEN THEREFORE PLAN DISTANCE  
                CALCULATED
- W798           POINT HAS LEVEL SPECIFIED, SLOPE DISTANCE  
                CALCULATED  
                NO NORMAL INTERSECTION FOUND
- W799           NO NORMALS FOUND
- W797           DATA INCOMPLETE FOR STRING label
- Major option COPY**
- W800           STRING IS NOT WITHIN BOUNDARY
- W801           'label' HAS NO POINTS NOT COPIED

W803	label RENAMED label
W806	STRING DOES NOT EXIST
W807	OPTION 063 IS NO LONGER VALID – USING OPTION 060 INSTEAD
W808	MORE THAN THREE DIMENSIONS FOUND - STRING IGNORED
W809	TRANSFORMATIONS RESET
W810	CADASTRE STRINGS IGNORED - CANNOT BE CURVE FITTED
W811	CADASTRE STRINGS IGNORED - SECOND MODELNAME MUST BE DIFFERENT TO FIRST MODELNAME
W812	SYMBOL REFERENCE BEARINGS ALTERED ON CADASTRE STRINGS
W813	GEOMETRY STRINGS WHICH INTERSECT BOUNDARY HAVE NOT BEEN COPIED  Geometry strings may only be copied as complete strings, therefore any Geometry string which intersects the boundary will not be copied. If the Geometry string is completely inside/outside the boundary it will be copied.

### **Major option VOLUME**

W820	SECTIONAL AREA AT CHAINAGE number ASSUMED ZERO  Occurs with the 050 option for the first and last sections through the boundary to confirm coverage of all the boundary.
W821	SECTION number CH number OMITTED  Either the string does not exist or the section has no points. The volume calculation allows for this and spans the gap.
W822	END OF SECTIONS IN MODEL name  This usually follows the previous message and indicates there are no more sections.
W823	UNABLE TO RESOLVE BOUNDARY OVERLAP

It has not been possible to create a closed boundary. The cause will be that the boundary has less than 3 points or too many points. The maximum number allowed is 3000.

**Major option CONTOUR**

- W860 SIMPLIFIED ISOPACHYTE TRIANGULATION MODEL IN USE
- W861 TRIANGLES IGNORED  
Triangles are ignored if the slope exceeds that specified on the 940 option.
- W862 POINT NOT WITHIN TRIANGULATION  
co-ordinates
- W863 CANNOT STORE TRIANGULATION  
WHILE USING A TEMPORARY MODEL
- W864 PROMINENT INTERVAL CHANGED TO  
MULTIPLE OF NORMAL: number
- W865 CANNOT RECALL OLD TRIANGULATION
- W866 CANNOT STORE OLD TRIANGULATION
- W867 CANNOT RECALL TRIANGULATION FOR  
ISOS PROCESSING
- The above three messages are reported when the field 10 has been coded as 1 on minor option 941. This invokes a previous method of triangulation which does not allow the facilities described in the messages.

**Major option TRIANGLE**

- W860 SIMPLIFIED ISOPACHYTE TRIANGULATION MODEL IN USE
- W868 TRIANGLE TRACE ON  
Output details of each point added to triangulation.
- W869 TRIANGLE TRACE OFF
- W870 FLAT TRIANGLES ALLOWED  
Identical levels of all three vertices.
- W871 FLAT TRIANGLES REMOVED
- W872 RECTIFYING CORRUPTED TRIANGULATION

Removal of temporary group codes if necessary.

- W873 TRIANGULATION n% COMPLETE
- W874 NUMBER OF UNGROUPED TRIANGLES - numberRr
- W875 THERE ARE NO UNGROUPED TRIANGLES  
The whole triangulation has already been grouped.
- W876 VIEW CALCULATIONS - number% COMPLETE
- W877 NUMBER OF GROUPEd TRIANGLES - number
- w878 NO TRIANGLES HAVE BEEN GROUPEd

### **Major option VIEW**

- W891 THE RESIDUAL ERROR IS LARGE  
If the average error in a photomontage point exceeds a value x the differences in the perspective view will probably be noticeable, for example the average distance between the defined point and the transformed picture is greater than x. X has a default value of 0.01 being the Point Search tolerance but this may be modified using minor option 017.
- W892 MINIMUM CANNOT BE FOUND  
In the iterative technique used in calculating the transformation parameters various estimates of the solution are made by the program. If for two successive iterations the error term is not reduced this message will be given. The cause of the warning will usually be poorly specified data, in terms of either accuracy or distribution of the photomontage points around the photograph.
- W893 NUMBER OF TRIANGLES IS number  
Where the hidden line removal is invoked the model needs to be triangulated and this warning indicates the extent of the triangulation.
- W894 NO. OF POINTS IN EDGE STRING = number  
The horizons of the view which are used to remove the hidden lines are not necessarily part of the strings. An edge is created so that when plotted a complete picture is shown. This warning tells the user how many points there are in the string.
- W895 LARGE AREA OF SHADOW ENCOUNTERED  
SOME HIDDEN LINES MAY REMAIN

As part of the process of hidden line removal there is a limit to the number of triangles that may be considered in the shadow of any particular ledge. If this is exceeded some of the triangles will be ignored. The shape of the model will indicate how the complexity can be reduced.

### **DPF COMPRESS**

W900            TOO MANY ERROR FILES FOR THIS DPF  
                 NO DPF COMPRESSION HAS TAKEN PLACE

### **OSPP warnings**

W925            WARNING - FEATURE CODE label REPEATED IN DATAFILE  
W926            WARNING - FEATURE CODE label HAS BEEN IGNORED  
W927            WARNING - FEATURE CODE label TREATED AS NULL CODE.  
W928            WARNING - number STRINGS IGNORED  
W929            WARNING - number STRINGS TREATED AS NULL  
W930            WARNING - UNKNOWN RECORD IDENTIFIER number,  
                 IGNORED  
W931            WARNING - BLANK LINE ENCOUNTERED AND IGNORED  
W932            WARNING - NOT ENOUGH CO-ORDINATES ON LINE number

### **Major option MACRO**

W951            MACRO REQUIRED NOT IN LIBRARY

### **Major option UPM**

W970            UPM SECURITY HAS COMPLETED SUCCESSFULLY  
W975            UPM VARIABLES HAVE BEEN INITIALISED

### **MSPLOTTER**

W980            NO STRINGS INSIDE PLOTTING AREA  
W981            NOTHING TO PLOT FOR SECTION Label.  
W982            BOUNDARIES OVERLAP



- W983            TEXT HEIGHT TOO SMALL,  
                  SET TO 0.01 CMS
- W984            PEN LIMIT EXCEEDED, PEN 1 USED

**Software font warnings**

- W985            FONT FILE NOT FOUND,  
                  HARDWARE FONT USED.  
                  The Font File eg 'FONT1.DAT' does not exist.
- W986            ERROR READING FONT FILE  
                  HARDWARE FONT USED  
                  An error has occurred whilst reading the Font File ie it is not of the  
                  correct format.

**Linemode VISUALISE warnings**

- W990            VISUALISATION DATA CLEARED
- W991            VISUALISATION FILE CREATED

**Message warnings**

- W997            PRINT message number IS NOT ON MESSAGE FILE
- W998            WARNING message number IS NOT ON MESSAGE FILE
- W999            ERROR message number IS NOT ON MESSAGE FILE

## MOSS system error messages

Messages in addition to the standard warning and error messages there is a set of system error messages. These are all numbered E99 and are printed as follows:–

### **E99 SYSTEM ERROR NNN**

JOB TERMINATED BECAUSE OF SYSTEM ERROR –  
ABNORMAL END OF JOB

The value of NNN indicates the source of the system error. Some additional information is printed for certain errors. These are two types of system error:–

Program Errors – any system error not described in the File Errors section below. Contact your MOSS supplier if a program error occurs.

File Errors – these are identified by the additional information printed.

### **Model File Errors**

Indicated by either of two messages:

MODEL FILE IS FULL OR CORRUPT

The model file was filled or corrupted by a previous run.

MODEL FILE IS FULL

The current run has filled the model file.

### **Macro File Errors**

Indicated by either of three messages:

INCORRECT MACROFILE RECORD ADDRESS

The macro file was filled or corrupted by a previous run.

INVALID INDICATOR TO S/R MACRO

MACRO FILE IS FULL

The current run has filled the macro file.

**Stop codes**

Will be in the form of:

STOP IT - DETECTED RETURN CODE - n - IN abcd  
ON RETURN FROM - efgh

and will be followed by a trace of the routines called by the current command.

It allows a more controlled exit from the software in the event of an unrecoverable error.

## Appendix 2

# Software fonts

[Authors comment = reference to this appendix is made in Minor option 808 chapter 3]

### Introduction

Software fonts enable you to design or supply your own character fonts, and to store them in font data files.

This gives you more choice and control over character output. Also, it means that your own character fonts or those designed by MSL can be transferred to plotters and external packages.

### Using software fonts

#### Graphics

To use a software font you must select Text in the Static Menu Area. When prompted for the text style enter 'sofX', where x is an alphanumeric in the range 1 to 9, a to z.

- ◇ *If you make an error in entering the softfont name, the system will report an error when it first attempts to use the font.*

#### Linemode

To use a software font you must code the DRAW minor option 808 in linemode as follows:

Field 1        The name of the required software font. This must be in the form sofX, where X is an alphanumeric in the range 1 to 9, a to z.

- ◇ *Each software font must have an associated font data file. Font data file names must be in the form fontX.fil, and must correspond with the software font name in the value taken by X. In other words if you code the software font name as sof1 then the font must be stored in a font data file named font1.fil.*
- ◇ *A maximum of 35 font data files may exist in the <language>sys sub directory for selection by DRAW minor option 808.*

### How to create software fonts

All the information required to create and implement your own software font is contained in the Guide to MOSS Software fonts. This Guide is part of the MOSS Document library and can be accessed using Major option DOCUMENT.

The final stage of software font implementation requires that a binary version of the font be created using MSFILE. This procedure is detailed in the System Manager's Reference for your hardware platform.

## Appendix 3

# User Support Service

A telephone support service is available to all users from their own local supplier. Those customers whose maintenance agreement is directly with MOSS Systems should use the UK support service Hotline available on the following numbers:

Telephone 01403 - 217749

Facsimile 01403 - 217728

Before calling the user support service please follow the check list below:

- Have you consulted the current documentation for a possible solution?
- Which MOSS option does your call concern?
- What type of hardware and current level of Operating System do you have?
- Which version of the MOSS software do you have?
- Is this the first occurrence of the problem? If yes, have any changes been made to the data, hardware or software configurations?
- Is it possible to reproduce the problem consistently?
- Are you currently unable to continue your operation as a result of the problem encountered?

## User report form

If the query cannot be resolved immediately, you may be requested to supply further data so that the support services can attempt to reproduce the problem. This should be accompanied by a completed User Report Form. On receipt of a user report MOSS Systems (or their agent) will initially endeavour to provide you with a 'workaround' solution. Should the software require modification, this will be incorporated in the next release of software. Very serious errors or omissions will be remedied at the earliest opportunity.

If it is necessary to supply data to enable your MOSS supplier to investigate a problem, use standalone program MSSUPPORT as described in the following section to write the data to a cartridge or diskette.

## Program MSSUPPORT

MSSUPPORT is a standalone program which writes a set of support files to cartridge or diskette. This enables your MOSS supplier to investigate a problem which cannot be solved immediately.

### Running the program

At the operating system prompt:

Type *MSSUPPORT*

A version and licence message is displayed. You are then presented with the following menu:

- 1 - Diskette
- 2 - Cartridge
- 3 - Other user configurable device
- 4 - Local directory
- 5 - Defined directory

99 - Exit

Enter the destination for the data :

Type the number corresponding to the destination where you wish to write your data.

The data may be written directly to backup media (options 1, 2 and 3), saved in your current working directory (option 4), or saved in a directory of your choice (option 5).

If you choose to write the data to a directory (ie, option 4 or 5), you should ensure that you have enough disk space available. The model file, macro file and DPF are all included in the support data and they may be large files.

Would you like to archive all relevant files as specified by your MOSS engineer ?

Type *y* to save the standard set of support files. Type *n* to be given the option of saving some of the files only. The program allows you to save additional files later.

The program lists each of the files to be written in turn. If any of the files are missing or not in the expected location, the following message is displayed:

```
Enter (Y) to abort and create it or (N) to  
continue ...
```

Type *y* to abort the program and attempt to locate or re-create the missing file. Type *n* to continue.

When all the files have been listed, the following message is displayed if data compression is available on your workstation:

```
Do you wish to compress your files before  
archiving ?
```

Type *y* to compress the files, or type *n* to continue.

Data compression can save a considerable amount of disk space if you are writing to a directory.

```
Are there any other files you would like to  
archive ?
```

Type *y* to save any additional files, followed by the full pathname of the file to be saved. Type *n* to continue.

```
Enter your callback reference (up to six  
characters) :
```

Type the callback reference given to you by your MOSS supplier.

The support files are now written to your chosen destination. If you have written them to a directory, the resulting file should be written to a device and sent to your MOSS supplier.



Data may be forwarded in the following recommended forms;

Hardware	Media	Recording Utility
Apollo and HP9000 Domain	1/4" Cartridge (45Mb & 60Mb) 8mm Exabyte	WBAK OMNIBACK
HP9000/UX	1/4" Cartridge (HP88140LC) 4mm DDS (HP92283A)	TAR, CPIO TAR, CPIO
IBM RS/6000	1/4" Cartridge (150Mb)	TAR, CPIO
Intergraph	1/4" Cartridge (150Mb)	TAR, CPIO
PC	5 1/4" Diskette DS/HD or 3 1/2" DS/HD Mini data cartridge	MS-DOS MS-DOS Colorado
Sun	1/4" Cartridge (45Mb, 60 Mb & 150Mb) 3 1/2" Diskette DS/HD 8mm Exabyte	TAR, CPIO  TAR, BAR, CPIO TAR
VAX	1600 BPI 1/2" tape, TK50, TK85	BACKUP
Silicon Graphics	4mm DDS (HP92283A)	TAR, CPIO
DECstation	TK50	TAR, CPIO

## New Development Enhancement Requests

The MOSS System is a general surface modelling survey and engineering system with special features for unique applications such as highway design. Extensive use of the system may indicate that either minor or major extensions are required to the system for:-

- New applications
- The changing requirements of existing applications
- Specialised engineering features
- Omissions in the existing specification
- User design practice
- National design practice

These extensions are accepted as the natural evolution of the system and are considered as enhancements. Users are requested to send details and examples on an Enhancement Request Form. These are then recorded and considered in the forward development programme.

[Contents](#)

[Index](#)

# USER REPORT FORM

Notified By: \_\_\_\_\_

Date Reported: \_\_\_\_/\_\_\_\_/\_\_\_\_

Company: \_\_\_\_\_

Machine: \_\_\_\_\_

Model: \_\_\_\_\_

Address: \_\_\_\_\_

Operating system: \_\_\_\_\_

Version number: \_\_\_\_\_

Window manager: \_\_\_\_\_

Version number: \_\_\_\_\_

Company Ref: \_\_\_\_\_

### Accompanying Data

- |           |                          |        |                          |
|-----------|--------------------------|--------|--------------------------|
| Listing   | <input type="checkbox"/> | Letter | <input type="checkbox"/> |
| Diskette  | <input type="checkbox"/> | Fax    | <input type="checkbox"/> |
| Cartridge | <input type="checkbox"/> | Plot   | <input type="checkbox"/> |

MOSS Version No: \_\_\_\_\_

Major option /Program: \_\_\_\_\_

Minor option / command: \_\_\_\_\_

Impact to your operation: Critical  Serious, but avoidable  Nuisance

Symptom(s): \_\_\_\_\_

Description / Procedure

### FOR MSL USE ONLY

- |                       |                          |                      |                          |
|-----------------------|--------------------------|----------------------|--------------------------|
| Reproduced            | <input type="checkbox"/> | Dataset(s) _____     |                          |
| User misunderstanding | <input type="checkbox"/> | Enhancement required | <input type="checkbox"/> |
| Further data required | <input type="checkbox"/> | No Action            | <input type="checkbox"/> |
| Fixed                 | <input type="checkbox"/> | Version _____        |                          |
| Comments:             |                          | Call back no. _____  |                          |

Date \_\_\_\_/\_\_\_\_/\_\_\_\_

Initials \_\_\_\_\_

MSL Ref: \_\_\_\_\_

[Contents](#)

[Index](#)

## USER REPORT FORM

Requested By: \_\_\_\_\_

Date Requested: \_\_\_\_/\_\_\_\_/\_\_\_\_

Company: \_\_\_\_\_

Company Ref: \_\_\_\_\_

Address: \_\_\_\_\_

\_\_\_\_\_

\_\_\_\_\_

\_\_\_\_\_

Current Version No:

Major option /Program:

Minor option / command:

Summary:

Description:

### FOR MSL USE ONLY

Accepted

Deferred

Transferred to U.R.S.

Further data required

Previous request X-reference: \_\_\_\_\_

Replied by: \_\_\_\_\_

Phone

Letter

Fax

Date \_\_\_\_/\_\_\_\_/\_\_\_\_

Initials \_\_\_\_\_

MSL Ref: \_\_\_\_\_

[Contents](#)

[Index](#)

## ENHANCEMENT REQUEST FORM

---

[Contents](#)

[Index](#)

**CONTINUATION TAX SHEET**  
**USER REPORT FORM**

---

[Contents](#)

[Index](#)

## USER REPORT FORM

---

**Callback No:**

**Hotline Fax No:**  
**United Kingdom**  
**International**

**01403 217728**  
**+44 1403 217728**

Your Name: \_\_\_\_\_

Your Telephone No. \_\_\_\_\_ Your Fax No. \_\_\_\_\_

**Hardware (eg PC):** \_\_\_\_\_ **Operating system (eg Windows NT):** \_\_\_\_\_

**MOSS Version No:** \_\_\_\_\_ **Major option:** \_\_\_\_\_ **Minor option:** \_\_\_\_\_

---

**Description:**

## Appendix 4

# SiteMOSS

## Introduction

SiteMOSS is for use by surveyors and engineers to hold on-site details of project design. It enables the user to extract data from any MOSS design model for setting out purposes, and gives survey, basic design and volumetric calculation capability.

The documentation set describes all major options in MOSS. However, if you have purchased SiteMOSS, only the documentation for the following listed major options applies.

## Major options

The SiteMOSS software comprises the following major options:

ALIAS	Give a model a temporary name.
ARCHIVE	Store models on the archive file.
AREA	Calculate areas.
ASSIGN	Direct output from GENIO or MACRO to a file.
BROWSE	Access alpha plane in IGMODE.
CLIP	Remove superfluous information from a DPF.
COMPRESS	Remove wasted space from a file.
COPY	Copy all or part of one model to another.
CREATE	Create a model.
DELETE	Delete a model.
DESIGN	Design of features. <i>Minor options 100, 101, 103, 104, 105, 110, 111 and 134.</i>
DISPLAY	Send a picture to a display screen.
DOCUMENT	Access online documentation.
DRAW	Output contents of the model in graphical form.
DUMP	Take a backup copy of the model file.

EDIT	Edit strings within a model.
ENHANCE	Annotate a drawing.
ERASE	Delete a model from the archive file
FINISH	End a session.
FREE	Allow updating of a model.
GENIO	Input and output of data from external files.
GLOBAL	Modify global settings. <i>Minor options 017, 018 and 019.</i>
INPUT	Process a pre-defined data set.
JOURNAL	User selective recording of input data.
LIST	List files showing structure.
MACRO	Create command macros, macrolines and macrosymbols.
MOSS	Start a new SiteMOSS job.
NEWDPF	Name a DPF to contain data.
NEWFILE	Create a new model, macro or plot file.
OUTPUT	Direct the output to a named output file.
OVERWRITE	Direct output from GENIO or MACRO to a file.
PRISM	Volume info from triangulated model.
REGAIN	Model file utility option.
RENAME	Rename a model.
REPORT	Output the contents of a model in printed form.
RESTORE	Restore a file from a backup copy.
RETRIEVE	Retrieve a model from the archive file.
SECTION	Determine sections through a model. <i>Minor options 170, 171, 173, 174, 1775 and 178.</i>
SECURE	Apply read - only security to a model.
SETOUT	Produce setting out data.
SUBSYSTEM	Access a subset of system commands.
SURFACE	Generate contours and isopachytes.
SURVEY	Create models by ground survey.
VOLUME	Calculate volumes. <i>Minor options 050, 051, 052, 053, 054, 055 and 056</i>
In addition, the following are available as optional purchases:	
HAUL	Mass haul analysis



VOLUME      Calculate volumes  
*Minor option 058*

## Standalone programs

Standalone programs which are provided include:

MSDISPLAY      Send a picture to a display screen.

MSDOCUMENT    Access online documentation.

MSPFRPT        Report on a DPF file

MSPLOTTER      Plot a picture.

MSSMTRANS     Input site measurements to SiteMOSS.

## Appendix 5

# VisMOSS

## Introduction

VisMOSS allows you to produce solid colour perspective views from a MOSS design. All the major options required to produce suitable models for EPIC images are included, together with the programs which make up the the rest of the EPIC product.

The documentation set describes all major options in MOSS. However, if you have purchased VisMOSS, only the documentation for the following listed major options applies.

For further details of EPIC, refer to the MOSS User Guide to EPIC (Volumes 1 and 2).

## Major options

The VisMOSS software comprises the following major options:

ALIAS	Give a model a temporary name.
ARCHIVE	Store models on the archive file.
BROWSE	Access alpha plane in IGMODE.
COMPRESS	Remove wasted space from a file.
COPY	Copy all or part of one model to another. <i>Minor option 060.</i>
CREATE	Create a model.
DELETE	Delete a model.
DESIGN	Design of features. <i>Minor options 110, 111 and 112.</i>
DISPLAY	Send a picture to a display screen.
DOCUMENT	Access online documentation.
DRAW	Output contents of the model in graphical form. <i>Excluding minor option 856.</i> <i>Excluding minor options 818, 819 and 856.</i>

DUMP	Take a backup copy of the model file.
EDIT	Edit strings within a model. <i>Minor options 004, 005, 008, 009, 012, 023, 024, 025, 026, 027, 028, 030, 031 and 032.</i>
ERASE	Delete a model from the archive file
FINISH	End a session.
FREE	Allow updating of a model.
GENIO	Input data from external files. <i>Minor option 080.</i>
GLOBAL	Modify global settings. <i>Minor options 017, 018 and 019.</i>
INPUT	Process a pre-defined data set.
JOURNAL	User selective recording of input data.
LIST	List files showing structure.
MACROSYMBOL	Create macrolines and macrosymbols interactively.
MOSS	Start a new job.
NEWDPF	Name a DPF to contain data
NEWFILE	Create a new model, macro or plot file.
OUTPUT	Direct output to a named output file.
REGAIN	Model file utility option.
RENAME	Rename a model.
REPORT	Output the contents of a model in printed form. <i>Minor options 987, 988, 989, 990, 991, 992, 995, 996, 997, 998</i>
RESTORE	Restore a file from a backup copy.
RETRIEVE	Retrieve a model from the archive file.
SECTION	Determine sections through a model. <i>Minor option 177.</i>
SECURE	Apply read - only security to a model.
SUBSYSTEM	Access a subset of system commands.
TRIANGLE	Create a triangulated surface from a model. <i>Minor options 960, 961 and 966.</i>
VISUALISE	Assign objects and materials to a model.

## Standalone programs

Standalone programs which are provided include:

EPIC                    Produce solid model from MOSS model data.

MSDOCUMENT Access online documentation.

MSPLOTTER    Plot a picture.

MSSHOW        Display an EPIC frame.

## Appendix 6

# Sys3MOSS

### Introduction

Sys3MOSS gives basic design capability to engineers who do not need access to all the functionality of MOSS.

The documentation set describes all major options in MOSS. However, if you have purchased Sys3MOSS, only the documentation for the following listed major options applies.

### Major options

The Sys3MOSS software comprises the following major options:

ALIAS	Give a model a temporary name.
ALIGNMENT	Create master alignments interactively.
ARCHIVE	Store models on the archive file.
AREA	Calculate areas.
ASSIGN	Direct output from GENIO or MACRO to a file.
BROWSE	Access alpha plane in IGMODE.
CLIP	Remove superfluous information from a DPF.
COMPRESS	Remove wasted space from a file.
COPY	Copy all or part of one model to another.
CREATE	Create a model.
DELETE	Delete a model.
DESIGN	Design of features.
DISPLAY	Send a picture to a display screen.
DOCUMENT	Access online documentation.
DRAW	Output contents of the model in graphical form.
DUMP	Take a backup copy of the model file.
EDIT	Edit strings within a model.
ENHANCE	Annotate a drawing.

ERASE	Delete a model from the archive file
FINISH	End a session.
FREE	Allow updating of a model.
GENIO	Input and output of data from external files.
GLOBAL	Modify global settings.
HALGN	Create horizontal alignment non-interactively.
INPUT	Process a pre-defined data set.
INTERFACE	Produce cut and fill interface strings.
JOURNAL	User selective recording of input data.
LAYOUT	Produce drawing sheets interactively.
LIST	Listing of files showing structure.
MACRO	Create command macros, macrolines and macrosymbols.
MACROSYMBOL	Create macrolines and macrosymbols interactively.
MOSS	Start a new job.
NEWDPF	Name a DPF to contain data
NEWFILE	Create a new model, macro or plot file.
OUTPUT	Direct the output to a named output file.
OVERWRITE	Direct output from GENIO or MACRO to a file.
REGAIN	Model file utility option.
RENAME	Rename a model.
REPLAY	Replays a MOSS session.
REPORT	Output the contents of a model in printed form.
RESTORE	Restore a file from a backup copy.
RETRIEVE	Retrieve a model from the archive file.
SECTION	Determine sections through a model.
SECURE	Apply read - only security to a model.
SETOUT	Production of setting out data.
SUBSYSTEM	Access a subset of system commands.
SURVEY	Create models by ground survey.
SURFACE	Generate contours from a triangulation. <i>Minor option 970.</i>
TRIANGLE	Create a triangulated surface from a model. <i>Minor options 960, 961 and 963.</i>
UPM	Run previously created UPMs.
VALGN	Create vertical alignment non-interactively.

VERAT	Create vertical alignment using intersection points.
VOLUME	Calculate volumes.

## Standalone programs

Standalone programs which are provided include:

MSDAMS	Convert DA format data to GENIO format.
MSDISPLAY	Send a picture to a display screen.
MSDOCUMENT	Access online documentation.
MSPLOTTER	Plot a picture.

## Appendix 7

# FranMOSS

### Introduction

FranMOSS is an entry-level version of MOSS for use by smaller engineering companies in France.

The documentation set describes all major options in MOSS. However, if you have purchased FranMOSS, only the documentation for the following listed major options applies.

### Major options

The FranMOSS software comprises the following major options:

ALIAS	Give a model a temporary name.
ALIGNMENT	Create master alignments interactively.
ARCHIVE	Store models on the archive file.
AREA	Calculate areas. <i>Minor options 040, 046, 047 and 048</i>
ASSIGN	Direct output from GENIO or MACRO to a file.
BROWSE	Access alpha plane in IGMODE.
COMPRESS	Remove wasted space from a file.
COPY	Copy all or part of one model to another. <i>Minor options 059, 060 and 061.</i> <i>Minor options 059 and 060</i>
CREATE	Create a model.
DELETE	Delete a model.
DESIGN	Design of features. <i>Minor options 100, 101, 103, 104, 105, 106, 107, 108, 110, 111, 120, 121, 130, 131, 133, 134 and 145.</i>
DOCUMENT	Access online documentation.
DRAW	Output contents of the model in graphical form.



	<i>Minor options 800-810, 812, 814, 815, 817, 821, 822, 825, 826, 830, 845-849, 857, 860-869 and 879</i>
DUMP	Take a backup copy of the model file.
EDIT	Edit strings within a model. <i>Minor options 004, 005, 006, 008, 009, 010, 022-031, 033, 035 and 036.</i>
ENHANCE	Annotate a drawing.
ERASE	Delete a model from the archive file
FINISH	End a session.
GENIO	Input and output of data from external files. <i>Minor options 080, 081 and 082.</i>
GLOBAL	Modify global settings.
HALGN	Create horizontal alignment non-interactively.
INPUT	Process a pre-defined data set.
INTERFACE	Produce cut and fill interface strings. <i>Minor options 260, 261, 262 and 263.</i>
JOURNAL	User selective recording of input data.
MACRO	Create command macros, macrolines and macrosymbols.
MOSS	Start a new FranMOSS job.
NEWDPF	Name a DPF to contain data.
OUTPUT	Direct the output to a named output file.
OVERWRITE	Direct output from GENIO or MACRO to a file.
REGAIN	Model file utility option.
RENAME	Rename a model.
REPORT	Output the contents of a model in printed form.
RESTORE	Restore a file from a backup copy.
RETRIEVE	Retrieve a model from the archive file.
SECTION	Determine sections through a model. <i>Minor options 171 and 173.</i>
SUBSYSTEM	Access a subset of system commands.
SURFACE	Generate contours from a triangulation. <i>Minor option 970.</i>
TRIANGLE	Create a triangulated surface from a model. <i>Minor options 960 and 961.</i>
UPM	Run previously created UPMs.

VALGN	Create vertical alignment non-interactively.
VIEW	Create perspective views. <i>Minor options 920, 921, 922 and 923.</i>
VOLUME	Calculate volumes. <i>Minor options 056 and 058</i>

## Standalone programs

Standalone programs which are provided include:

MSDISPLAY Send a picture to a display screen.

MSDOCUMENT Access online documentation.

MSPLOTTER Plot a picture.

## Appendix 8

# MiniMOSS

### Introduction

MiniMOSS is an entry-level version of MOSS for use by smaller engineering companies throughout the world.

The documentation set describes all major options in MOSS. However, if you have purchased MiniMOSS, only the documentation for the following listed major options applies.

### Major options

The MiniMOSS software comprises the following major options:

ALIAS	Give a model a temporary name.
ALIGNMENT	Create master alignments interactively.
ARCHIVE	Store models on the archive file.
AREA	Calculate areas. <i>Minor options 040 and 041</i>
ASSIGN	Direct output from GENIO or MACRO to a file.
BROWSE	Access alpha plane in IGMODE.
COMPRESS	Remove wasted space from a file.
COPY	Copy all or part of one model to another. <i>Minor options 060</i>
CREATE	Create a model.
DELETE	Delete a model.
DESIGN	Design of features. <i>Minor options 100, 101, 102, 110, 111, 112, 120, 121, 122, 130, 131, 132, 134, 140, 141, 142, 145.</i>
DOCUMENT	Access online documentation.
DRAW	Output contents of the model in graphical form. <i>Excluding 827, 828, 829, 831, 856 and 870</i>

	<i>Excluding 827, 828, 829, 831 and 870</i>
DUMP	Take a backup copy of the model file.
EDIT	Edit strings within a model. <i>Minor options 004-010, 020-026, 030, 031, 032, 035 and 036.</i>
ENHANCE	Annotate a drawing.
ERASE	Delete a model from the archive file
FINISH	End a session.
GENIO	Input and output of data from external files.
GLOBAL	Modify global settings.
INPUT	Process a pre-defined data set.
INTERFACE	Produce cut and fill interface strings.
JOURNAL	User selective recording of input data.
MACRO	Create command macros, macrolines and macrosymbols.
MOSS	Start a new MiniMOSS job.
NEWDPF	Name a DPF to contain data.
OUTPUT	Direct the output to a named output file.
OVERWRITE	Direct output from GENIO or MACRO to a file.
REGAIN	Model file utility option.
RENAME	Rename a model.
REPORT	Output the contents of a model in printed form.
RESTORE	Restore a file from a backup copy.
RETRIEVE	Retrieve a model from the archive file.
SECTION	Determine sections through a model. <i>Minor options 170, 171, 173, 174, 175 and 176.</i>
SURFACE	Generate contours from a triangulation. <i>Minor option 970.</i>
TRIANGLE	Create a triangulated surface from a model. <i>Minor options 960 and 961.</i>
UPM	Run previously created UPMs.
VIEW	Create perspective views. <i>Minor options 920, 921 and 923.</i>
VOLUME	Calculate volumes. <i>Minor options 050, 052-056</i>
2DDXF	Produce DXF drawings.

## Standalone programs

Standalone programs which are provided include:

MSDISPLAY	Send a picture to a display screen.
MSDOCUMENT	Access online documentation.
MSPLOTTER	Plot a picture.
MS2DDXF	Produce DXF drawings.

## Appendix 9

# CzechMOSS

### Introduction

CzechMOSS is an entry-level version of MOSS for use by smaller engineering companies in the Czech Republic.

The documentation set describes all major options in MOSS. However, if you have purchased CzechMOSS, only the documentation for the following listed major options applies.

### Major options

The MiniMOSS software comprises the following major options:

ALIAS	Give a model a temporary name.
ALIGNMENT	Create master alignments interactively.
ARCHIVE	Store models on the archive file.
AREA	Calculate areas. <i>Minor options 040 and 041</i>
ASSIGN	Direct output from GENIO or MACRO to a file.
BROWSE	Access alpha plane in IGMODE.
COMPRESS	Remove wasted space from a file.
COPY	Copy all or part of one model to another. <i>Minor options 060</i>
CREATE	Create a model.
DELETE	Delete a model.
DESIGN	Design of features. <i>Minor options 100, 101, 102, 110, 111, 112, 120, 121, 122, 130, 131, 132, 134, 140, 141, 142, 145.</i>
DOCUMENT	Access online documentation.
DRAW	Output contents of the model in graphical form. <i>Excluding 827, 828, 829, 831, 856 and 870</i>

DUMP	Take a backup copy of the model file.
EDIT	Edit strings within a model. <i>Minor options 004-010, 020-026, 030, 031, 032, 035 and 036.</i>
ENHANCE	Annotate a drawing.
ERASE	Delete a model from the archive file
FINISH	End a session.
GENIO	Input and output of data from external files.
GLOBAL	Modify global settings.
INPUT	Process a pre-defined data set.
INTERFACE	Produce cut and fill interface strings.
JOURNAL	User selective recording of input data.
MACRO	Create command macros, macrolines and macrosymbols.
MOSS	Start a new MiniMOSS job.
NEWDPF	Name a DPF to contain data.
OUTPUT	Direct the output to a named output file.
OVERWRITE	Direct output from GENIO or MACRO to a file.
REGAIN	Model file utility option.
RENAME	Rename a model.
REPORT	Output the contents of a model in printed form.
RESTORE	Restore a file from a backup copy.
RETRIEVE	Retrieve a model from the archive file.
SECTION	Determine sections through a model. <i>Minor options 170, 171, 173, 174, 175 and 176.</i>
SURFACE	Generate contours from a triangulation. <i>Minor option 970.</i>
TRIANGLE	Create a triangulated surface from a model. <i>Minor options 960 and 961.</i>
UPM	Run previously created UPMs.
VIEW	Create perspective views. <i>Minor options 920, 921 and 923.</i>
VOLUME	Calculate volumes. <i>Minor options 050, 052-056</i>
2DDXF	Produce DXF drawings.

## Standalone programs

Standalone programs which are provided include:

MSDISPLAY	Send a picture to a display screen.
MSDOCUMENT	Access online documentation.
MSPLOTTER	Plot a picture.
MS2DDXF	Produce DXF drawings.