

What's New in OpenBridge Designer CONNECT Edition v10.08?

Dec, 2019

Version	V10.08
Operating Systems	Windows 8 x64, Windows 10 x64
Language	English

What is New & Changed?

- 1) Rebar modeling tools (ProConcrete tools) in OpenBridge Designer's OpenBridge Modeler component.

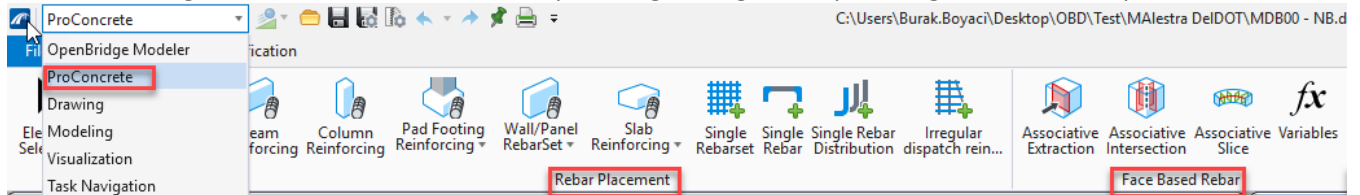

- 2) Enhanced BIM workflow functionality and advanced user interface consolidation of LEAP Bridge Concrete component.

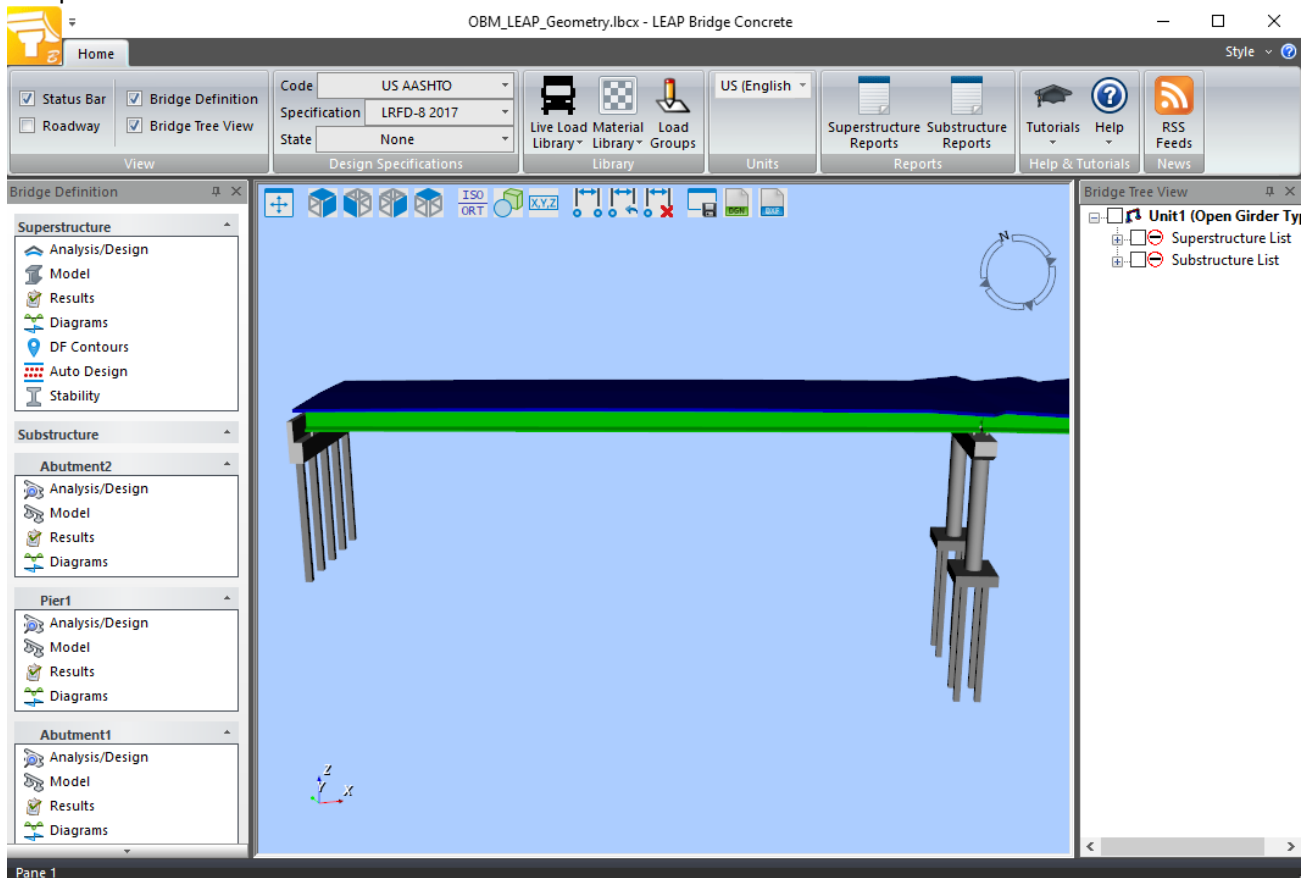

- 3) Import & Export functionality for OpenBridge Designer projects. It is now much easier to share your projects with others. Exporting operation of an .obd file results in a single file including all component files (and others). This single file can be imported and the ingredients of the .obd file (all component files) will be extracted to a location user selects. OpenBridge Designer intelligently creates new file paths for each project file to the location user selected.

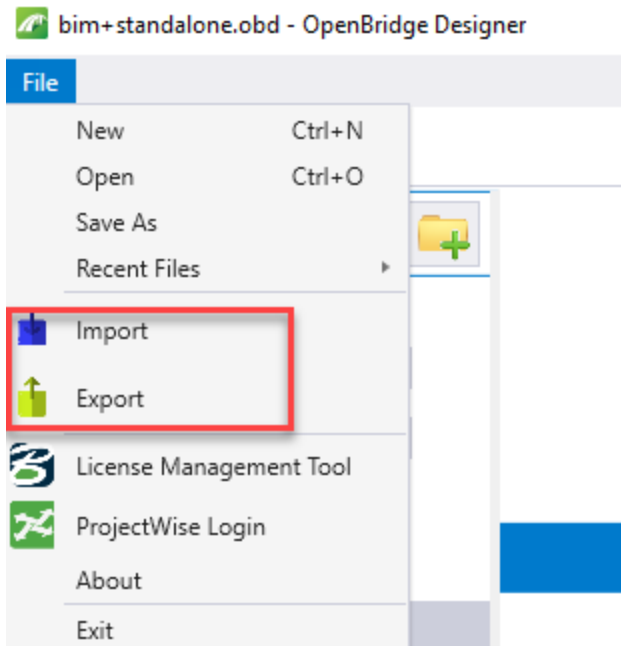

Subscription Entitlement Service (SES):

This product version utilizes Subscription Entitlement Service, which is not supported by SELECT activation key(s). SES is a free service, featuring new behavior to enhance your organization's user administration and security with mandatory user sign-in via CONNECTION Client to access the application. If you are already signed in to the CONNECTION Client, you have met this prerequisite. If you have not, please refer to the Administrator's Resource Center and/or contact your administrator for assistance in the registration and sign-in process.

Note: You may need to contact your system administrator if your organization uses a proxy server to connect to the Internet. Click the Proxy... button in the Product Activation Wizard to display a dialog for entering these connection settings.
